

CONTENTS	PAGE
■ 1. Use	2
■ 2. Technical characteristics	2
2.1 Connections characteristics	2
2.2 Installation	2
2.3 Consumption	2
2.3.1 KNX supply	2
2.3.2 Mains supply	2
2.3.3 DALI supply	2
2.4 Output	2
2.5 Mechanical characteristics	2
2.6 Climate characteristics	2
2.7 Operating elements	2
2.8 Application program	2
■ 3. Dimensions	2
■ 4. Connection	3
■ 5. Operation	3
5.1 Description of the device	3
5.2 Operation and Display	3
■ 6. Standards	3
■ 7. Communication objects	4
7.1 Communication Object Table	4
7.2 Communication Object Descriptions	4
7.3 ETS Parameters	7
7.3.1 General	7
7.3.2 Feedback	8
7.3.3 Fault Condition	8
7.3.4 DALI Devices (1...64)	8
7.3.5 Scenes	9

1. USE

KNX-DALI Gateway Ref. 0 026 99 operates as an interface device between KNX bus and DALI bus. Device can control 64 DALI devices on a DALI line. This DALI line is powered by internal power supply. DALI compatible ECGs (electronic control gear) can be controlled individually.

Device features are listed below:

- Maximum 64 DALI devices (e.g. electronic ballast, transformer) can be connected to DALI output.
- 0 026 99 enables to control 64 DALI devices individually and can store 16 different lighting scenes.
- Fault statuses of DALI devices can be monitored by both device based via different communication objects on the KNX.
- Bus voltage fail/return states can be selected on ETS parameters.
- Addressing of DALI devices is made via DALI Tool (PC Software). DALI Tool can be downloaded from website www.legrand.fr.

Note:

Each channel is uniform. Device factory default physical address is "15.15.255".

2. TECHNICAL CHARACTERISTICS

2.1 Connections characteristics

- Screw terminals: 0,05 - 2,5mm² solid wire
0,03 - 1,5mm² stranded wire
- Max tightening torque: 0.5Nm
- KNX terminal: red - grey bus connect terminal

2.2 Installation

- 35mm mounting rail

2.3 Consumption

2.3.1 KNX supply

- Voltage: 21 - 30V DC, SELV
- Current consumption: < 10 mA

2.3.2 Mains supply

- Voltage: 85 - 300V AC
- Frequency: 50-60Hz
- Power consumption: Max. 8W
- Current consumption: 100mA - 85V AC

2.3.3 DALI supply

- Voltage: 16V DC typical
- Current: Max. 200mA

2.4 Output

- Number of DALI devices: Max. 64
- Cable lengths: 1.5 mm² (Max. 300 m)
0.75 mm² (Max. 150 m)
0.5 mm² (Max. 100 m)

2. TECHNICAL CHARACTERISTICS (continued)

2.5 Mechanical characteristics

- IP 20
- Safety class II
- Number of modules: 4
- Weight: 150 g

2.6 Climate characteristics

- Operating temperature: -5°C to +45°C
- Storage temperature: -25°C to +55°C
- Max. air humidity: 95% no moisture condensation

2.7 Operating elements

- Programming LED and button: physical address localization
- Green LED: KNX power OK
- Yellow LED: Initialization active (fast blink)
A DALI device fault present (slow blink)
Main power failure (constant on)
- Red LED: manual operation active
- Manual button: activate the manual test
- Test button: switch-dim DALI output (on manual mode)

2.8 Application program

- Communications object count: 218
- Number of address (max): 254
- Number of assignments (max): 255

3. DIMENSIONS

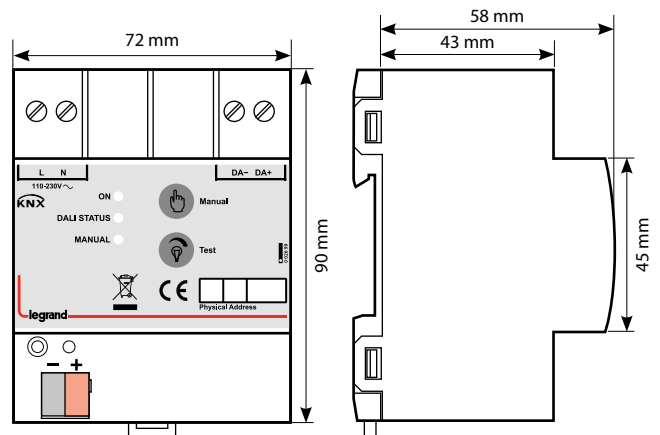

4. CONNECTION

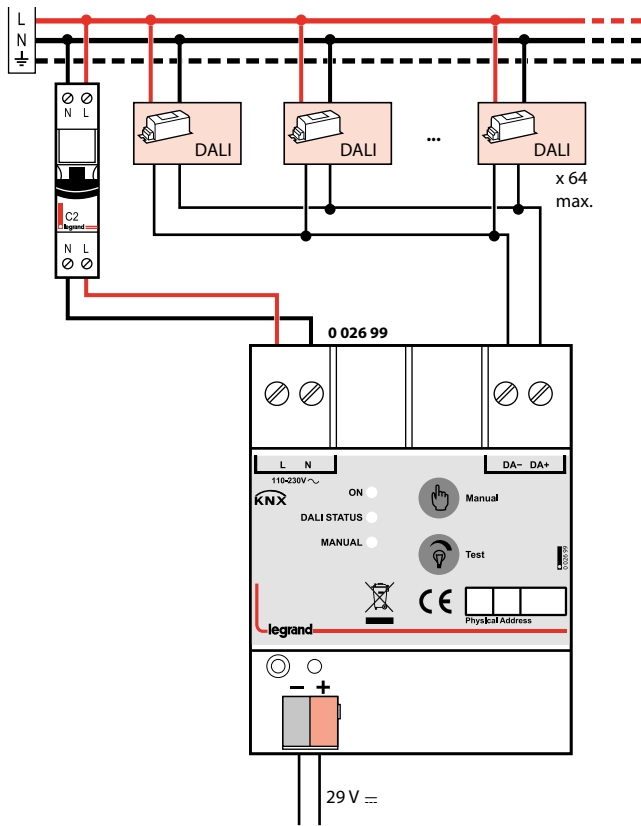

5. OPERATION (continued)

5.2 Operation and Display

Power OK LED:

- OFF: KNX BUS failure.
- ON: KNX BUS connected.

DALI Status LED:

- OFF: No problem.
- ON: DALI line failure. Possible causes; mains supply failure, DALI line is short-circuit, mains power is connected to DALI line.
- Slow Blink: A DALI device fault is present. (Fault lamp, fault ballast, ...)
- Fast Blink: Initialization is active.

Manual LED: Lights up when manual control is activated by pressing manual button.

Manual Button: Activate/Deactivate manual control. (Press the manual button for 3 seconds to activate. Press shortly to deactivate manual control.)

Note: KNX commands cannot operated when manual control is activated.

Test Button: If manual operation is activated, short press sends broadcast on/off command and long press sends broadcast dim up/down command to DALI line. (Commands are sent in sequent.)

Programming LED and Button: Physical address localization.

6. STANDARDS

- Type of protection: EN 60529
- Safety class III: IEC 61140
- CE: In accordance with the EMC guideline and low voltage directives

5. OPERATION

5.1 Description of the device

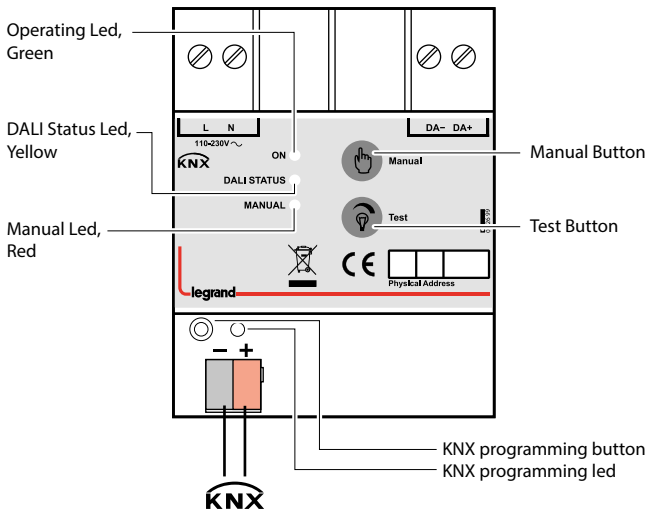

7. COMMUNICATION OBJECTS

7.1 Communication Object Table

Overview of all communication objects of the device application can be seen on the following table.

No	Name	Function	DTP Type	Length	Flags
0	In operation	General	1.002	1 bit	CT
1	Enable manual operation	General	1.003	1 bit	CRW
2	New devices addressing	General	1.003	1 bit	CW
3	Field capture	General	1.003	1 bit	CW
4	Request all statuses	General	1.003	1 bit	CW
5	Device status	Feedback	Non-DPT	3 bytes	CWT
6	Coded status switch	Feedback	Non-DPT	2 bytes	CWT
7	Coded status brightness value	Feedback	Non-DPT	2 bytes	CWT
8	Coded faults	Feedback	237.600	2 bytes	CWT
9	DALI line fault	Feedback	1.005	1 bit	CRT
10	Mains connection fault	Feedback	1.005	1 bit	CRT
11	Lamp fault	Feedback	1.005	1 bit	CRT
12	Device fault	Feedback	1.005	1 bit	CRT
13	Main power failure status	Feedback	1.005	1 bit	CRT
14	Scene 8 bit	Scene	17.001	1 byte	CW
15	0=Scene 1, 1=Scene 2	Scene	1.022	1 bit	CW
16	0=Scene 3, 1=Scene 4	Scene	1.022	1 bit	CW
17	0=Scene 5, 1=Scene 6	Scene	1.022	1 bit	CW
18	0=Scene 7, 1=Scene 8	Scene	1.022	1 bit	CW
19	0=Scene 9, 1=Scene 10	Scene	1.022	1 bit	CW
20	0=Scene 11, 1=Scene 12	Scene	1.022	1 bit	CW
21	0=Scene 13, 1=Scene 14	Scene	1.022	1 bit	CW
22	0=Scene 15, 1=Scene 16	Scene	1.022	1 bit	CW
23	Broadcast Switch	Broadcast	1.001	1 bit	CWU
24	Broadcast set brightness value	Broadcast	5.001	1 byte	CW
25	Broadcast relative dimming	Broadcast	3.007	4 bits	CWU
26...215	Switch	Dali device 1...64	1.001	1 bit	CWU
	Switch/Status				CWTU
	Switch/Status				CRWU
	Switch/Status				CRWTU
27...216	Set brightness value	Dali device 1...64	5.001	1 byte	CWU
	Set brightness value/Status				CWTU
	Set brightness value/Status				CRWU
	Set brightness value/Status				CRWTU
28...217	Relative dimming	Dali device 1...64	3.007	4 bits	CW

7. COMMUNICATION OBJECTS (continued)

7.2 Communication Object Descriptions

No	Name	Function	DTP Type	Length	Flags
0	In operation	General	1.002	1 bit	CT

This object is used to report that device is still alive and connected to the KNX line by sending cyclic 1 bit telegrams. If a telegram is not received, device may be defective or KNX cable would be intercepted.

- Object will be activated if "**Device alive operation active**" parameter in the General tab is selected as "**enable**".
- Telegram type (ON or OFF) can be selected via "**In operation bit**" parameter in General parameters tab.
- Cyclic period of transmitted telegrams can be selected via "**In operation send interval**" parameter in General parameters tab.

1	Enable manual operation	General	1.003	1 bit	CRW
---	-------------------------	---------	-------	-------	-----

This object is used for enabling or disabling the manual operation button located on the device. If the manual operation disabled, manually switching or dimming of the connected DALI devices is not possible. Furthermore, the status of manual operation can be read via this communication object.

- Value of the object will be "**1**" after an ETS download if the "**Enable manual operation**" parameter in General tab is selected as "**enable**". Value will be "**0**" if parameter is selected as "**no**".

(value "1" = manual operation enable, value "0" = manual operation disable)

2	New devices addressing	General	1.010	1 bit	CW
---	------------------------	---------	-------	-------	----

This object is used to start addressing the all DALI devices randomly. If there is even addressed devices before, they will re-addressed again. Please send "enable(1)" to this group object to start this function.

3	Field capture	General	1.010	1 bit	CW
---	---------------	---------	-------	-------	----

This object is used to read and save all DALI devices to 0 026 99 device which can be found by scan. Un-addressed devices will be addressed and conflicted addressed will be resolved. Please send "enable(1)" to this group object to start this function.

Note: if statuses are wrong or zero please perform this operation.

4	Request all statuses	General	1.010	1 bit	CW
---	----------------------	---------	-------	-------	----

This object is used to read all status by triggering this object when needed. Status information will be sent via Coded objects (if activated) and via Switch/Status or Set brightness value/Status object (if activated). Please send "**enable(1)**" to this group object to start this function.

7. COMMUNICATION OBJECTS (continued)

7.2 Communication Object Descriptions (continued)

No	Function	Name	DPT type	Length	Flags
5	Device status	Feedback	Non-DPT	3 bytes	CWT

This communication object is used for getting all current faults and states of a DALI device in one comprehensive telegram. In order to make a read request, a write should be made to object with read/response bit is set.

Object consists of three bytes. Higher two bytes of telegram contains all fault and state data and lowest byte contains DALI address of subjected device and information of whether telegram is a status request or sent status.

- Object will be activated if “**Enable “Device status” object**” parameter in Feedback tab is selected as “**enable**”.
- Feedback will be sent only after a request if “**transmit mode**” parameter in Feedback tab is selected as “**after request**” or only after a value change if parameter is selected as “**after change**”. Feedback will be sent on both occasions if the parameter is selected as “**after change or request**”.

Bit numbers and data which they represented is explained below:

23	22	21	20	19	18	17	16	15	14	13	12	11	10	9	8	7	6	5	4	3	2	1	0
----	----	----	----	----	----	----	----	----	----	----	----	----	----	---	---	---	---	---	---	---	---	---	---

Byte	Bit Field	Description
1	Bit 0 - 5	DALI device address [0 - 63]
	Bit 6	Reserved and should be '0'
	Bit 7	Read or response flag: '1' = read, '0' = response
2	Bit 8	Device offline flag: '1' = offline, '0' = online
	Bit 9	Device malfunction flag: '1' = failure '0' = no failure
	Bit 10	Lampe failure flag: '1' = failure '0' = no failure
	Bit 11	Reserved and should be '0'
	Bit 12	Reserved and should be '0'
	Bit 13	Reserved and should be '0'
	Bit 14	Reserved and should be '0'
	Bit 15	Reserved and should be '0'
	Bit 16	Reserved and should be '0'
	Bit 17	Reserved and should be '0'
3	Bit 18	Reserved and should be '0'
	Bit 19	Short circuit flag: '1' = failure, '0' = no failure (LED only)
	Bit 20	Open circuit flag: '1' = failure, '0' = no failure (LED only)
	Bit 21	Current protector active flag: '1' = failure, '0' = no failure (LED only)
	Bit 22	Thermal shutdown flag: '1' = failure, '0' = no failure (LED only)
	Bit 23	Reserved

No	Function	Name	DPT type	Length	Flags
6	Coded status switch	Feedback	Non-DPT	2 byte	CWT

This object is used to get switch status of a DALI group or an individual DALI ballast/driver. In order to make a read request, a write should be made to object with read/response bit is set.

- Object consists of two bytes. High byte of telegram contains switch status and low byte contains DALI address of subjected device or group number, information of whether telegram is a status request or sent status and information of whether a device or a group is selected.
- Object will be activated if “**Enable “Coded status switch ” object**” parameter in Feedback tab is selected as “**enable**”.
- Feedback will be sent only after a request if “**transmit mode**” parameter in Feedback tab is selected as “**after request**” or only after a value change if parameter is selected as “**after change**”. Feedback will be sent on both occasions if the parameter is selected as “**after change or request**”.

Bit numbers and data which they represented is explained below:

15	14	13	12	11	10	9	8	7	6	5	4	3	2	1	0
----	----	----	----	----	----	---	---	---	---	---	---	---	---	---	---

Byte	Bit Field	Description
1	Bit 0 - 5	DALI device address [0 - 63] or DALI group number[0 - 15]
	Bit 6	Individual device or group flag: '1' = device address, '0' = group number
	Bit 7	Read or response flag: '1' = read, '0' = response
2	Bit 8	Switch status: '1' = ON, '0' = OFF (DPT 1.001)
	Bit 9-15	Reserved

7. COMMUNICATION OBJECTS (continued)

7.2 Communication Object Descriptions (continued)

No	Function	Name	DPT type	Length	Flags
7	Coded status brightness value	Feedback	Non-DPT	2 byte	CWT

This object is used to get brightness value of a DALI group or an individual DALI ballast/driver. In order to make a read request, a write should be made to object with read/response bit is set.

Object consists of two bytes. High byte of telegram contains brightness value and low byte contains DALI address of subjected device or group number, information of whether telegram is a status request or sent status and information of whether a device or a group is selected.

- Object will be activated if “**Enable “Coded status brightness value” object**” parameter in Feedback tab is selected as “**enable**”.
- Feedback will be sent only after a request if “**transmit mode**” parameter in Feedback tab is selected as “**after request**” or only after a value change if parameter is selected as “**after change**”. Feedback will be sent on both occasions if the parameter is selected as “**after change or request**”.

Bit numbers and data which they represented is explained below:

15	14	13	12	11	10	9	8	7	6	5	4	3	2	1	0
----	----	----	----	----	----	---	---	---	---	---	---	---	---	---	---

Byte	Bit Field	Description
1	Bit 0 - 5	DALI device address [0 - 63] or DALI group number[0 - 15]
	Bit 6	Individual device or group flag: '0' = device address, '1' = group number
	Bit 7	Read or response flag: '1' = read, '0' = response
2	Bit 8 - 15	Brightness value [0 - 255] (DPT 5.001)

No	Function	Name	DPT type	Length	Flags
8	Coded faults	Feedback	237.600	2 byte	CWT

This object is used to get fault data of a DALI group or an individual DALI device. In order to make a read request, a write should be made to object with read/response bit is set.

Object consists of two bytes. High byte of telegram contains fault data and low byte contains DALI address of subjected device or group number, information of whether telegram is a status request or sent status and information of whether a device or a group is selected.

- Object will be activated if “**Enable “Coded faults” object**” parameter in Feedback tab is selected as “**enable**”.
- Feedback will be sent only after a request if “**transmit mode**” parameter in Feedback tab is selected as “**after request**” or only after a value change if parameter is selected as “**after change**”. Feedback will be sent on both occasions if the parameter is selected as “**after change or request**”.

Bit numbers and data which they represented is explained below:

15	14	13	12	11	10	9	8	7	6	5	4	3	2	1	0
----	----	----	----	----	----	---	---	---	---	---	---	---	---	---	---

Byte	Bit Field	Description
1	Bit 0 - 5	DALI device address [0 - 63] or DALI group number[0 - 15]
	Bit 6	Individual device or group flag: '1' = device address, '0' = group number
	Bit 7	Read or response flag: '1' = read, '0' = response
2	Bit 8	Device is offline or malfunction flag: '1' = failure '0' = no failure
	Bit 9	Lamp failure flag: '1' = failure '0' = no failure
	Bit 10	Reserved
	Bit 11-15	Reserved

No	Function	Name	DPT type	Length	Flags
9	DALI line fault	Feedback	1.005	1 bit	CRT

This object is used for reporting DALI gateway supply fault. Possible causes of the fault are no mains connection to gateway supply terminal, power supply malfunction or short circuiting DALI line more than 100ms.

- Object will be activated if “**Enable “Fault gateway supply” object**” parameter in Feedback tab is selected as “**enable**”.
- Feedback will be sent only after a request if “**transmit mode**” parameter in Feedback tab is selected as “**after request**” or only after a value change if parameter is selected as “**after change**”. Feedback will be sent on both occasions if the parameter is selected as “**after change or request**”.

(value “0” = gateway supply works properly, value “1” = gateway supply fault)

7. COMMUNICATION OBJECTS (continued)

■ 7.2 Communication Object Descriptions (continued)

No	Function	Name	DTP Type	Length	Flags
10	Mains connection fault	Feedback	1.005	1 bit	CRT

This object is used for reporting DALI gateway mains connection fault. Possible causes of the fault are no mains connection to gateway supply terminal.

- Object will be activated if “**Enable “Mains connection fault” object**” parameter in Feedback tab is selected as “**enable**”.
- Feedback will be sent only after a request if “**transmit mode**” parameter in Feedback tab is selected as “**after request**” or only after a value change if parameter is selected as “**after change**”. Feedback will be sent on both occasions if the parameter is selected as “**after change or request**”.

(value “0” = gateway supply works properly,
value “1” = Mains connection fault)

No	Function	Name	DTP Type	Length	Flags
11	Lamp fault	Feedback	1.005	1 bit	CRT

This object is used for reporting whether there is any device that has a fault lamp is present or not.

- Object will be activated if “**Enable “Lamp fault” object**” parameter in Feedback tab is selected as “**enable**”.
- Feedback will be sent only after a request if “**transmit mode**” parameter in Feedback tab is selected as “**after request**” or only after a value change if parameter is selected as “**after change**”. Feedback will be sent on both occasions if the parameter is selected as “**after change or request**”.

(value “0” = no fault lamp,
value “1” = at least one of the DALI devices has a lamp fault)

No	Function	Name	DTP Type	Length	Flags
12	Device fault	Feedback	1.005	1 bit	CRT

This object is used for reporting whether there is any offline or malfunctioned ballast/driver is present or not.

- Object will be activated if “**Enable “Device fault” object**” parameter in Feedback tab is selected as “**enable**”.
- Feedback will be sent only after a request if “**transmit mode**” parameter in Feedback tab is selected as “**after request**” or only after a value change if parameter is selected as “**after change**”. Feedback will be sent on both occasions if the parameter is selected as “**after change or request**”.

(value “0” = no ballast/driver fault,
value “1” = at least one of the DALI ballasts/drivers is offline or malfunctions)

No	Function	Name	DTP Type	Length	Flags
13	Mains power failure status	Feedback	1.005	1 bit	CRT

This object is used for reporting a misconnection of mains to the DALI line.

- Object will be activated if “**Enable “Fault mains connected” object**” parameter in Feedback tab is selected as “**enable**”.
- Feedback will be sent only after a request if “**transmit mode**” parameter in Feedback tab is selected as “**after request**” or only after a value change if parameter is selected as “**after change**”. Feedback will be sent on both occasions if the parameter is selected as “**after change or request**”.

(value “0” = no misconnection,
value “1” = mains connected to DALI line)

Note:

Overvoltage sense circuitry on the DALI line is triggered on voltages above 40V. So any voltage above 40V is considered as mains.

7. COMMUNICATION OBJECTS (continued)

■ 7.2 Communication Object Descriptions (continued)

No	Function	Name	DTP Type	Length	Flags
14	Scene 8 bit	Scene	17.001	1 byte	CW

This object is used to recall up to 16 scenes that are available on the gateway device.

- Object is always enabled.
- Even devices which is not shown on ETS parameters can be controlled via scenes properly.

Note:

Scene save function is not available.

Bit numbers and data which they represented is explained below;

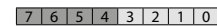

Byte	Bit Field	Description
1	Bit 0 - 3	Scene number - 1 [0 - 15 for scenes 1 - 16]
	Bit 4 - 7	Reserved and should be 0

Example of recall byte codes for scenes;

Scene	recall	
	Hexadecimal	Decimal
1	0x00	0
2	0x01	1
3	0x02	2
4	0x03	3
5	0x04	4
6	0x05	5
7	0x06	6
8	0x07	7
9	0x08	8
10	0x09	9
11	0x0A	10
12	0x0B	11
13	0x0C	12
14	0x0D	13
15	0x0E	14
16	0x0F	15

No	Function	Name	DTP Type	Length	Flags
15	0=Scene 1, 1=Scene 2	Scene	1.022	1 bit	CW

This object is used for recalling scene 1 or scene 2.

(value “0” = recall scene 1,
value “1” = recall scene 2)

16...22	0=Scene 3...15, 1=Scene 4...16 same as before
---------	---

No	Function	Name	DTP Type	Length	Flags
23	Broadcast Switch	Broadcast	1.001	1 bit	CWU

This object is used to switch all connected DALI ballasts on or off. You can configure broadcast switched on brightness value, using “**Brightness value when switch on**” parameter.

No	Function	Name	DTP Type	Length	Flags
24	Broadcast Set brightness value	Broadcast	5.001	1 byte	CWU

This object is used to set the brightness value of all connected DALI ballasts.

7. COMMUNICATION OBJECTS (continued)

7.2 Communication Object Descriptions (continued)

No	Function	Name	DTP Type	Length	Flags
25	Broadcast Relative dimming	Broadcast	3.007	4 bit	CW

This object is used to dim all connected DALI ballast. The brightness value is changed in the defined direction with the parameterized speed.

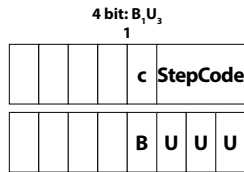

c = {0,1}
StepCode = [000b...111b]
 c Increase or decrease the brightness 0 – decrease
 1 – increase
 StepCode The amount of intervals into which the range of 0 % ... 100 % is subdivided or the break indication. - 001b ... 111b: Step
 Number of interval = (2)^{StepCode-1}
 - 000b : Break

GENERAL NOTE(Broadcast Control):

Broadcast control objects are not dependent to Individual control group objects. Thus, individually controlled device statuses will not be taking into account for Broadcast control group objects.

If Broadcast Relative Dim group object is willing to used, Broadcast Switch or Broadcast Absolute Dim control is required.

If Broadcast control applied firstly, status values will be taking into account for individual control group objects.

26...215	Switch/Status	Dali Device 1...64	1.001	1 bit	CWTU
----------	---------------	--------------------	-------	-------	------

This object is used to switch DALI device 1...64 ON or OFF.

27...216	Set brightness value	Dali Device 1...64	5.001	1 byte	CWTU
----------	----------------------	--------------------	-------	--------	------

This object is used to set DALI Device 1...64 brightness value (%0...%100).

28...217	Relative dimming	Dali Device 1...64	3.007	4 bit	CW
----------	------------------	--------------------	-------	-------	----

This object is used to dimming group 1. The brightness value is changed in the defined direction with the parameterized speed.

7. COMMUNICATION OBJECTS (continued)

7.3 ETS Parameters

“Parameters” chapter describes ETS parameters of the device. Please find detailed descriptions of objects in **7.2 Communication Object Description**. Default parameters are written in bold letters.

7.3.1 General

Enable manual Operation	*enable no
--------------------------------	---------------

Parameter determines whether lightings can be controlled manually or not by push button on DALI Gateway. If parameter is selected “enable”; manual operation will be possible. (For manual control: Hold down manual button for 3 seconds than press test button consecutively.)

Device alive beacon	enable *disable
----------------------------	--------------------

This object is used to report that device is still alive and connected to KNX line. (Heartbeat) If alive telegram is not received, device may be defective or KNX cable can be disconnected. If parameter is selected “enable”, following parameters come up.

In operation value	*true false
---------------------------	----------------

Telegram value can be selected as “1” or “0”.

Operation send interval [sec]	1...*300...65535
--------------------------------------	------------------

Telegram value is sent cyclically according to time interval.

Telegram limit function	enable *disable
--------------------------------	--------------------

Telegrams which are sent by the gateway can be limited with this parameter. If “enable” is selected, following parameters come up.

Telegram limit period	50ms...*100ms...1min
------------------------------	----------------------

The limit period can be selected via telegram limit period parameter.

Max. number of transmitted telegrams within a period	*1...255
---	----------

Maximum number of telegrams can be sent freely within a period.

Minimum brightness value limit	*no limit, %5(13)...%90(230)
---------------------------------------	------------------------------

This parameter defines the minimum brightness value of DALI devices. All DALI devices take this value as undermost brightness value and cannot accept lower brightness values.

Maximum brightness value limit	*no limit, %95(242)...%10(26)
---------------------------------------	-------------------------------

This parameter defines the maximum brightness value of DALI devices. All DALI devices take this value as upper limit brightness value and cannot accept higher values.

Allow switch on via brightness value	*yes no
---	------------

Allow switch off via brightness value	*yes no
--	------------

Allow switch on via relative dimming	*yes no
---	------------

Allow switch off via relative dimming	*yes no
--	------------

“Switch on” and “Switch off” conditions can be defined for brightness value and relative dimming commands separately. If these parameters are selected “no”, then it is not possible to switch “on” or “off” the lighting fixtures via brightness value (1 byte) or relative dimming (4 bit) objects of the group.

Fade time (switch, brightness value and dim commands)	jump to...1s...90 s
--	---------------------

These parameter defines the fade time for switch, brightness value and relative dimming commands per device.

Brightness value when switch on	Last switch on value, 5% (13) ...*100% (255)
--	--

This parameter defines the brightness value when a “switch on” command is received over Switch communication object.

7. COMMUNICATION OBJECTS (continued)

■ **7.3 ETS parameter (continued)**

7.3.2 Feedback

Enable "DALI line fault" object	enable *disable
---------------------------------	--------------------

Parameter enables "Fault gateway supply" object. This object is used for reporting DALI gateway supply fault. Possible causes of the fault are no mains connection to gateway supply terminal, power supply malfunction or short circuiting DALI line more than 100ms. Please check **7.2 Communication Object Descriptions** for detailed object information.

Enable "Mains connection fault" object	enable *disable
--	--------------------

Parameter enables "Fault mains connected" object. This object is used for reporting a misconnection of mains to the DALI line.

Enable "Lamp fault" object	enable *disable
----------------------------	--------------------

Parameter enables "Fault lamp" object. This object is used for reporting whether there is any device that has a fault lamp is present or not.

Enable "Device fault" object	enable *disable
------------------------------	--------------------

Parameter enables "Fault ballast" object. This object is used for reporting whether there is any offline or malfunctioned ballast/driver is present or not.

Enable "Device status" object	enable *disable
-------------------------------	--------------------

Parameter enables "Device status" object. This communication object is used for getting all current faults and states of a DALI device in one comprehensive telegram.

Enable "Coded status switch" object	enable *disable
-------------------------------------	--------------------

Parameter enables "Coded status switch" object. This object is used to get switch status of a DALI group or an individual DALI ballast/driver.

Enable "Coded status brightness value" object	enable *disable
---	--------------------

Parameter enables "Coded status brightness" object. This object is used to get brightness value of a DALI group or an individual DALI ballast/driver.

Enable "Coded faults" object	enable *disable
------------------------------	--------------------

Parameter enables "Coded faults" object. This object is used to get fault data of a DALI group or an individual DALI device.

Enable "Mains power failure status" object	enable *disable
--	--------------------

Parameter enables "Main power failure status" object. This object is used for reporting a no mains connection applied to the mains line of 0 026 99 KNX-DALI Gateway device.

Transmit mode description is the same for all parameters in Feedback tab. But selections can be made independently for each parameter.

Transmit mode	*after request after change after request or change
---------------	---

"After request" option only response to a read request to status object. "After change" mode always sends the status of object when changed. If both selected, object will send the status with a change and response to read requests.

7. COMMUNICATION OBJECTS (continued)

■ **7.3 ETS parameter (continued)**

7.3.3 Fault Condition

Lamp values on power on	0%(0)...100%(255) *value before power off
-------------------------	--

Parameter defines the brightness value of ballasts when power on.

Lamp values on DALI voltage failure	0%(0)...100%(255) *no change
-------------------------------------	---------------------------------

Parameter defines the brightness value of ballasts on DALI line voltage loss.

Lamp values on DALI voltage recovery	0%(0)...100%(255) *no change
--------------------------------------	---------------------------------

Parameter defines the brightness value of ballasts on DALI voltage return.

Lamp values on KNX voltage failure	0%(0)...100%(255) *no change
------------------------------------	---------------------------------

Parameter defines the brightness value of ballasts on KNX line voltage loss.

Lamp values on KNX voltage recovery (gateway reset)	0%(0)...100%(255) *no change
---	---------------------------------

Parameter defines the brightness value of ballasts on KNX voltage return.

7.3.4 DALI Devices (1...64)

Dali devices must be enabled to control via switch, brightness or relative dim communication objects.

Activate devices 1 – 16	*no yes
Activate devices 17 – 32	*no yes
Activate devices 33 – 48	*no yes
Activate devices 49 – 64	*no yes

Dali device count can be selected in this page. This page only activates the DALI device control objects. Unselected device addresses can still be controlled in scenes.

7.3.4.1 Device 1...64

Switch status response mode	*no transmission after request after change after change or request
-----------------------------	--

Switch status of the group can be read from this object itself or separate status object. "No response" option disables the "Read" flag of object.

"After request" mode; status object only response to a read request. "After change" mode; status object always sends its status when changed. If both selected; object will send the status with a change and response to read requests.

Brightness value status response mode	*no transmission after request after change after change or request
---------------------------------------	--

Brightness value status of the group can be read from this object itself or separate status object. "No response" option disables the "Read" flag of object.

"After request" mode; status object only response to a read request. "After change" mode; status object always sends its status when changed. If both selected; object will send the status with a change and response to read requests.

7. COMMUNICATION OBJECTS (continued)

■ 7.3 ETS parameter (continued)

7.3.5 Scenes

0 026 99 KNX-DALI Gateway can store 16 different lighting scenes. All of 16 scenes can be recalled only via "**Scene 8 bit**" object. A maximum of 16 scenes can be recalled and store via "**0=Scene x, 1=Scene y**" 1 bit communication object as well.

Activate scenes 1...16	*no yes
------------------------	------------

Scene count can be selected in this page. This page only activates the DALI device control objects. Unselected device addresses can still be controlled in scenes.

All scenes are disabled as default and they can be enabled by selecting "enable" in Scenes tab. "Scene x" tab will be available after enabled.

7.3.5.1 Scene 1...16

Fade time	*jump to, 0,7s...90s
-----------	----------------------

Fade time can be selected for related scene.

Device 1...64 brightness value	*no change 0% (0)...100% (255)
--------------------------------	-----------------------------------

Select the brightness value of ballasts for related scene.