

**DE** MONTAGEANLEITUNG  
**EN** MOUNTING INSTRUCTIONS  
**FR** INSTRUCTIONS DE MONTAGE  
**IT** ISTRUZIONI DI MONTAGGIO  
**ES** INSTRUCCIONES DE MONTAJE  
**NL** MONTAGEHANDLEIDING  
**PL** INSTRUKCJA MONTAŻU



**TRILUX**  
SIMPLIFY YOUR LIGHT

## SOLVAN FLOW C CDP-I LED

SFLOW C1...CDP-I...  
SFLOW ACT C1...CDP-I...  
SFLOW C2...CDP-I...  
SFLOW ACT C2...CDP-I...  
SFLOW C3...CDP-I...  
SFLOW ACT C3...CDP-I...  
SFLOW ACT C3...CDP-I...LL...

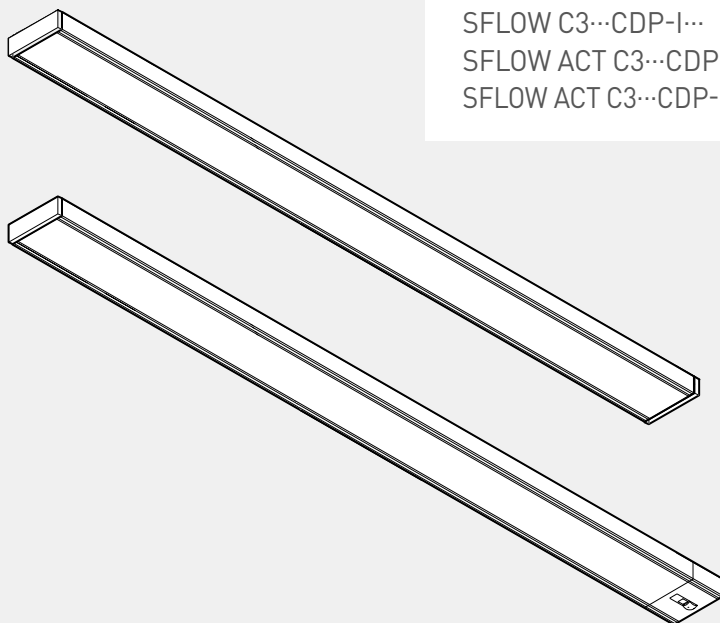

10217035 | 220427

**DE****SOLVAN FLOW C CPI-I LED****Zu Ihrer Sicherheit**

Lesen Sie sorgfältig alle Hinweise und Montageschritte. Bewahren Sie die Anleitung für Wartungs- oder Demontearbeiten auf.

**Erläuterung der Warnstufen**

Beachten und befolgen Sie die Warnhinweise. Nichtbeachten der Warnhinweise kann zu Verletzungen oder Sachschäden führen!



**WARNUNG!** Kennzeichnet Gefahren, die schwere und/oder tödliche Verletzungen zur Folge haben können.



**VORSICHT!** Kennzeichnet Gefahren, die zu Verletzungen oder Gesundheitsgefährdungen führen können.



**WICHTIG.** Kennzeichnet Gefahren, die zu Sachschäden oder Funktionsstörungen führen können.



**TIPP.** Kennzeichnet Informationen, die einen Ratschlag oder nützlichen Hinweis enthalten.

**Erläuterung wichtiger Symboliken und Piktogramme**

Kennzeichnet fachkundiges Personal, das ausgebildet und befugt ist, den elektrischen Anschluss auszuführen.



Kennzeichnet fachkundiges Personal, das ausgebildet und befugt ist, die Montage auszuführen.

**Sicherheitshinweise**

**WARNUNG!** Gefahr eines elektrischen Schlages! Arbeiten Sie niemals bei anliegender Spannung.



**WARNUNG!** Gefahr eines elektrischen Schlages! Die Lichtquelle dieser Leuchte darf nur vom Hersteller oder einem von ihm beauftragten Servicetechniker oder einer vergleichbar qualifizierten Person ersetzt werden. Bei Störungen oder Ausfall der Lichtquelle wenden Sie sich bitte an TRILUX.



**WICHTIG.** Decken Sie das Produkt nicht mit Dämmmaterial ab.



**VORSICHT!** Verletzungsgefahr! Montieren Sie die Leuchtenkomponenten mit Schutzhandschuhen.

**Wichtige Hinweise zu elektronischen Betriebsgeräten (EVG)**

Eine Neutralleiterunterbrechung im Drehstromkreis führt zu Überspannungsschäden in der Beleuchtungsanlage. Öffnen Sie die Neutralleiter-Trennklemme nur spannungsfrei und schließen Sie die Neutralleiter-Trennklemme vor Wiedereinschalten. Die maximal zulässige Umgebungstemperatur  $t_a$  der Leuchte darf nicht überschritten werden. Eine Überschreitung reduziert die Lebensdauer, im Extremfall droht ein Frühausfall der Leuchte. Legen Sie die Anschlussleitungen von DALI-Betriebsgeräten (1-10 V, DALI, etc.) 230 V netzspannungsfest (Basisisolierung) aus.

**Bestimmungsgemäße Verwendung**

Bestimmt für Innenräume mit einer max. Umgebungstemperatur von:  **$t_a$  25 °C**

Schutzklasse: **I**

Schutzart: **IP20**

**Entsorgung von Elektro- und Elektronik-Altgeräten**

Sammeln und entsorgen Sie Elektro- und Elektronik-Altgeräte am Ende ihrer Lebensdauer immer getrennt. Holen Sie sich im Zweifel Auskunft zur umweltgerechten Entsorgung bei der örtlichen Kommunalbehörde oder speziellen Entsorgungsfachbetrieben ein. Aktuelle Informationen zur Energieeffizienzklasse der gewählten Produktvariante finden Sie im entsprechenden Datenblatt der Leuchte. Hinweise zum Austausch oder zur Demontage des Leuchtmittels gemäß Verordnung 2019/2020/EU finden Sie unter:

[www.trilux.com/EcoDesign](http://www.trilux.com/EcoDesign)

**SOLVAN FLOW C CDP-I LED****EN****For your safety**

Read all instructions and mounting steps carefully. Keep the instructions for maintenance or disassembly work.

**Explanation of the warning levels**

Observe and follow the warnings. Non-observance of the warnings may lead to injuries or material damage!



**WARNING!** Indicates dangers which can result in serious and/or fatal injuries.



**CAUTION!** Indicates dangers which can result in injuries or health hazards.



**NOTICE.** Indicates dangers which can result in material damage or malfunctions.



**TIP.** Indicates information containing advice or a useful note.

**Explanation of important symbols and pictograms**

Indicates professional personnel who are trained and authorised to carry out the electrical connection.



Indicates professional personnel who are trained and authorised to carry out the mounting.

**Safety notes**

**WARNING!** Risk of electric shock! Never work with voltage applied.



**WARNING!** Risk of electric shock! The light source of this luminaire shall only be replaced by the manufacturer or a service technician authorised by the manufacturer or a similar qualified person. If the light source malfunctions or fails, please contact TRILUX.



**NOTICE.** Do not cover the product with insulating material.



**CAUTION!** Risk of injury! Install the luminaire components using protective gloves.

**Important information on electronic control gear units (ECG)**

A neutral conductor interruption in the three-phase circuit leads to overvoltage damage in the lighting system. Only open the neutral conductor isolating terminal in de-energised state, and close the neutral conductor isolating terminal before switching on again. Do not exceed the maximum permissible ambient temperature  $t_a$  of the luminaire. Exceeding this limit reduces the service life and in extreme cases there is a risk of premature failure of the luminaire. Design connection cables for the control inputs of DALI control gear (1-10 V, DALI etc.) to be 230 V mains voltage-proof (basic insulation).

**Intended use**

Intended for indoor use with a maximum ambient temperature of:  **$t_a$  25 °C**

Safety class: **I**

Protection rating: **IP20**

**Disposal of waste electrical and electronic equipment**

Always collect and dispose of old electrical and electronic equipment separately at the end of its service life. In case of doubt, seek information about environmentally-compliant waste disposal from your local district authority or special waste disposal companies. Current information on the energy efficiency class of the selected product version can be found in the corresponding data sheet for the luminaire. Instructions for replacing or removing the light source in accordance with Regulation 2019/2020/EU can be found at: [www.trilux.com/EcoDesign](http://www.trilux.com/EcoDesign)



FR

## SOLVAN FLOW C CPI-I LED

**Pour votre sécurité**

Lisez attentivement toutes les remarques et étapes de montage. Conservez ces instructions pour des travaux d'entretien ou de démontage.

**Explication des niveaux d'avertissement**

Respectez et suivez les avertissements. Le non-respect des avertissements peut entraîner des blessures ou des dommages matériels !



**AVERTISSEMENT !** Signale des risques pouvant résulter dans des blessures graves et/ou mortelles.



**ATTENTION !** Signale des risques pouvant entraîner des blessures ou des risques pour la santé.



**IMPORTANT.** Signale des risques pouvant entraîner des dommages matériels ou des dysfonctionnements.



**CONSEIL.** Signale des informations contenant un conseil ou une remarque utile.

**Explication des symboles et pictogrammes importants**

Signale un personnel qualifié, formé et autorisé à effectuer le raccordement électrique.



Signale un personnel qualifié, formé et autorisé à effectuer le montage.

**Recommandations de sécurité**

**AVERTISSEMENT !** Risque d'électrocution ! Ne travaillez jamais sous tension.



**AVERTISSEMENT !** Risque d'électrocution ! Seul le fabricant ou, soit un technicien de service mandaté par ce dernier, soit une personne ayant une qualification équivalente pourra se charger de remplacer la source de lumière de ce luminaire. En cas de perturbations ou défaillances de la source lumineuse, veuillez vous adresser à TRILUX.



**NOTICE.** Do not cover the product with insulating material.



**IMPORTANT.** Portez toujours des gants de montage propres afin d'éviter des encrassements.

**Remarques importantes concernant les ballasts électroniques (BE)**

Une interruption du conducteur neutre dans le circuit de courant triphasé entraîne des dommages de surtension dans l'installation d'éclairage. Ouvrez la borne de coupure du conducteur neutre lorsque l'installation est hors tension et fermez-la avant la remise sous tension. Ne dépassez jamais la température ambiante maximale admissible  $t_a$  du luminaire. Un dépassement réduit la durée de vie et peut, au pire, entraîner une défaillance prématurée du luminaire. Dimensionnez les câbles d'alimentation pour les entrées de commande des appareillages DALIs (1 à 10 V, DALI, etc.) afin qu'ils supportent une tension de secteur de 230 V (isolation de base).

**Utilisation conforme à l'usage prévu**

Conçu pour des espaces intérieurs à la température ambiante maximale de :  $t_a$  25 °C

Classe électrique : I

Indice de protection : IP20

**Élimination de DEEE**

À la fin de leur durée de vie, collectez et éliminez toujours les DEEE de manière sélective. Si vous avez des doutes sur une élimination sans danger pour l'environnement, demandez auprès des autorités locales ou d'entreprises de valorisation. Vous trouverez des informations actuelles sur la classe d'efficacité énergétique de la version de produit choisie dans la feuille de données correspondante du luminaire. Vous trouverez des instructions sur l'échange ou le démontage de la lampe selon le règlement (UE) 2019/2020 à l'adresse : [www.trilux.com/EcoDesign](http://www.trilux.com/EcoDesign)

## SOLVAN FLOW C CDP-I LED

IT

**Per la propria sicurezza**

Leggere con attenzione tutti gli avvisi e le descrizioni delle varie fasi della procedura di montaggio. Conservare le istruzioni per poterle consultare al momento di eseguire lavori di manutenzione e smontaggio.

**Spiegazione dei livelli di avvertenza**

Osservare e attenersi alle avvertenze. Una mancata osservanza delle avvertenze può essere causa di lesioni o danni materiali!



**AVVERTENZA!** Mette in guardia dai pericoli che possono comportare lesioni gravi e/o mortali.



**ATTENZIONE!** Mette in guardia da pericoli che possono essere causa di lesioni o rischi per la salute.



**AVVISO.** Mette in guardia da pericoli che possono essere causa di danni materiali o disturbi di funzionamento.



**SUGGERIMENTO.** Indica informazioni comprendenti un consiglio o un avviso utile.

**Spiegazione di importanti simboli e pittogrammi**

Indica personale specializzato in possesso di formazione e autorizzazione necessarie per eseguire l'allacciamento elettrico.



Indica personale specializzato in possesso di formazione e autorizzazione necessarie per eseguire il montaggio.

**Avvertenze di sicurezza**

**AVVERTENZA!** Pericolo di scarica elettrica! Mai lavorare in presenza di tensione.



**AVVERTENZA!** Pericolo di scarica elettrica! La sorgente luminosa di questo apparecchio deve essere sostituita dal produttore o da un tecnico di assistenza incaricato dallo stesso oppure da una persona in possesso di qualifica paragonabile. In caso di disturbi o guasto della sorgente luminosa si prega di rivolgersi a TRILUX.



**NOTICE.** Do not cover the product with insulating material.



**ATTENZIONE!** Pericolo di lesioni! Montare i componenti dell'apparecchio usando guanti protettivi.

**Avvisi importanti sui reattori elettronici**

Un'interruzione del conduttore di neutro nel circuito trifase provoca danni da sovratensioni nell'impianto di illuminazione. Aprire il morsetto di sezionamento del conduttore di neutro solo senza tensione e chiuderlo prima del reinserimento. La massima temperatura ambiente ammissibile ( $t_a$ ) dell'apparecchio non deve essere oltrepassata. Questo ridurrebbe altrimenti la durata utile e, nel caso estremo, si rischierebbe un guasto precoce dell'apparecchio. Realizzare i cavi di allacciamento per ingressi di comando di alimentatori DALI (1-10 V, DALI ecc.) in modo che presentino rigidità dielettrica con tensione di rete di 230 V (isolamento base).

**Impiego secondo destinazione**

Destinato all'impiego in interni con una temperatura ambiente massima ( $t_a$ ) di 25 °C

Classe di isolamento: I

Grado di protezione: IP20

**Smaltimento di rifiuti di apparecchiature elettriche ed elettroniche**

Alla fine del loro periodo di durata utile, raccogliere e smaltire i rifiuti di apparecchiature elettriche ed elettroniche sempre in modo differenziato. Nel dubbio, si raccomanda di chiedere informazioni su uno smaltimento conforme alla normativa ambientale presso le autorità municipali del posto o aziende specializzate nello smaltimento di rifiuti. Per informazioni aggiornate sulla classe di efficienza energetica della variante di prodotto scelta si rimanda alla scheda tecnica del rispettivo apparecchio. Indicazioni sulla sostituzione o lo smontaggio della lampada secondo regolamento 2019/2020/UE possono essere consultate su: [www.trilux.com/EcoDesign](http://www.trilux.com/EcoDesign)

**ES****SOLVAN FLOW C CPI-I LED****Para su seguridad**

Por favor, lea detenidamente todas las indicaciones y los pasos de montaje. Guarde las instrucciones para los trabajos de mantenimiento y desmontaje.

**Explicación de los niveles de alerta**

Por favor, tenga en cuenta y siga las indicaciones de peligro. ¡El incumplimiento de las indicaciones de peligro puede provocar lesiones o daños materiales!



**¡ADVERTENCIA!** Indica peligros que pueden provocar lesiones graves y/o mortales.



**¡ATENCIÓN!** Indica peligros que pueden provocar lesiones y riesgos de salud.



**¡IMPORTANTE!** Indica peligros que pueden provocar daños materiales o fallos de funcionamiento.



**CONSEJO.** Indica información con un consejo o una pista útil.

**Explicación de los símbolos y pictogramas importantes**

Indica personal profesional formado y autorizado para la realización de la conexión eléctrica.



Indica personal profesional formado y autorizado para la realización del montaje.

**Avisos de seguridad**

**¡ADVERTENCIA!** ¡Riesgo de descarga eléctrica! Nunca realice trabajos si esta tiene tensión.



**¡ADVERTENCIA!** ¡Riesgo de descarga eléctrica! La fuente de luz de esta luminaria debe ser sustituida por el fabricante, por un técnico de servicio encargado por él o por una persona de cualificación similar. En caso de fallos o averías de la fuente de luz, por favor, póngase en contacto con TRILUX.



**NOTICE.** Do not cover the product with insulating material.



**¡ATENCIÓN!** ¡Peligro de lesión! Instale los componentes de la luminaria utilizando guantes de protección.

**Avisos importantes en lo referente a los balastos electrónicos (EVGs)**

Una interrupción del conductor neutro en el circuito de corriente trifásica provoca daños por sobretensión en la instalación de iluminación. Solamente abra el borne desconector del conductor neutro cuando este esté desconectado de la tensión y cierre el borne desconector del conductor neutro antes de la reconexión. No debe sobrepasarse la temperatura ambiente máxima admitida de la luminaria. Al sobrepasarla, la vida útil se reduce y, en un caso extremo, puede provocarse un fallo prematuro de la luminaria. Los cables de conexión para las entradas de control de los equipamientos eléctricos DALI (EVGs) regulables (1-10 V, DALI, etc.) 230 V deben ser resistentes a la tensión de red (aislamiento básico).

**Uso previsto**

Destinado para espacios interiores con una temperatura ambiente máxima: **ta de 25 °C**

Grado de protección: I

Grado de protección: **IP20**

**Eliminación de dispositivos eléctricos y electrónicos antiguos**

Recoja y elimine los dispositivos eléctricos y electrónicos antiguos siempre por separado al final de su vida útil. En caso de duda, consulte las autoridades comunales o las empresas especializadas en eliminación de residuos para tener información sobre la eliminación respetuosa con el medio ambiente. En la ficha técnica de la luminaria correspondiente puede encontrar información actualizada sobre la clase de eficiencia energética de la variante de producto seleccionada. Para indicaciones sobre sustitución o desmontaje de la lámpara según el reglamento 2019/2020/EU consulte: [www.trilux.com/EcoDesign](http://www.trilux.com/EcoDesign)

**SOLVAN FLOW C CDP-I LED****NL****Voor uw veiligheid**

Lees alle aanwijzingen en montagestappen zorgvuldig. Bewaar de handleiding voor latere onderhouds- of demontagewerkzaamheden.

**Verklaring van de waarschuwningsniveaus**

Neem de waarschuwingen in acht en volg de instructies. Bij niet-naleving kan letsel of materiële schade het gevolg zijn!



**WAARSCHUWING!** Wijst op gevaren die zware en/of dodelijke letsels tot gevolg kunnen hebben.



**VOORZICHTIG!** Wijst op gevaren die kunnen leiden tot letsels of gezondheidsrisico's.



**BELANGRIJK!** Wijst op gevaren die kunnen leiden tot materiële schade of functionele storingen.



**TIP.** Wijst op informatie die een advies of een nuttige aanwijzing bevat.

**Verklaring van belangrijke symbolen en pictogrammen**

Verwijst naar vakkundig personeel dat opgeleid en bevoegd is om de elektrische aansluiting uit te voeren.



Verwijst naar vakkundig personeel dat opgeleid en bevoegd is om de montage uit te voeren.

**Veiligheidsinstructies**

**WAARSCHUWING!** Gevaar voor een elektrische schok! Werk nooit terwijl deze onder spanning staat.



**WAARSCHUWING!** Gevaar voor een elektrische schok! De lichtbron van deze armatuur moet worden vervangen door de fabrikant, een door de fabrikant gemachtigd servicetechnicus of een persoon met vergelijkbare kwalificaties. Neem contact op met TRILUX in geval van een storing of uitval van de lichtbron.



**NOTICE.** Do not cover the product with insulating material.



**VOORZICHTIG!** Gevaar voor lichamelijk letsel! Draag beschermende handschoenen bij het monteren van de armatuurcomponenten.

**Belangrijke aanwijzingen met betrekking tot elektronische voorschakelapparaten (EVSA's)**

Een onderbreking van de nulleider in de draaistroomkring veroorzaakt schade door overspanning in de verlichtingsinstallatie. Open de nullem alleen als de kring spanningsvrij is en sluit de nullem alvorens de spanning weer in te schakelen. De maximale toelaatbare omgevingstemperatuur (ta) van de armatuur mag niet overschreden worden. Overschrijding van de maximumtemperatuur kan de levensduur van de armatuur verkorten en in extreme gevallen zelfs leiden tot vroegtijdige uitval. De aansluitleidingen voor sturingangen van DALI-hulpapparaten (1-10 V, DALI enz.) moeten geschikt zijn voor een netspanning van 230 V (basisisolatie).

**Bedoeld gebruik**

Bedoeld voor binnengebruik bij een maximum omgevingstemperatuur van: **ta 25 °C**

Beschermcategorie: I

Beschermklasse: **IP20**

**Afvoer van afgedankte elektrische en elektronische apparaten**

Afgedankte elektrische en elektronische apparaten moeten altijd gescheiden van het andere afval worden bewaard en afgevoerd. Vraag in geval van twijfel aan de plaatselijke bevoegde openbare dienst of een gespecialiseerd afvalverwerkingsbedrijf hoe u deze apparaten afdankt met respect voor het milieu. Actuele informatie over de energie-efficiëntieklasse van de geselecteerde productvariant vindt u in het betreffende gegevensblad van de armatuur. Aanwijzingen met betrekking tot de vervanging of demontage van de lichtbron conform Verordening (EU) 2019/2020 vindt u op: [www.trilux.com/EcoDesign](http://www.trilux.com/EcoDesign)



PL

SOLVAN FLOW C CPI-I LED

**Zasady bezpieczeństwa**

Należy uważnie przeczytać wszystkie instrukcje i czynności montażowe. Zachować instrukcję na wypadek konserwacji lub demontażu.

**Wyjaśnienie poziomów ostrzegania**

Przestrzegać wskazówek ostrzegawczych. Nieprzestrzeganie wskazówek ostrzegawczych może spowodować obrażenia ciała lub szkody rzeczowe!



**OSTRZEŻENIE!** Oznacza zagrożenia, które mogą prowadzić do poważnych i/lub śmiertelnych obrażeń ciała.



**UWAGA!** Oznacza zagrożenia, które mogą prowadzić do obrażeń ciała lub zagrożenia dla zdrowia.



**WSKAZÓWKA.** Oznacza zagrożenia, które mogą prowadzić do szkód materialnych lub nieprawidłowego działania.



**PORADA.** Oznacza informacje, które zawierają poradę lub przydatną wskazówkę.

**Wyjaśnienie ważnych symboli i piktogramów**

Oznacza wykwalifikowany personel, który jest przeszkolony i upoważniony do wykonania przyłącza elektrycznego.



Określa kompetentny personel, który jest przeszkolony i upoważniony do przeprowadzenia montażu.

**Wskazówki bezpieczeństwa**

**OSTRZEŻENIE!** Niebezpieczeństwo porażenia prądem elektrycznym! Nigdy nie pracować pod napięciem.



**OSTRZEŻENIE!** Niebezpieczeństwo porażenia prądem elektrycznym! Źródło światła tej oprawy może być wymieniane wyłącznie przez producenta, wyznaczonego przez niego technika serwisu lub porównywalnie wykwalifikowaną osobę. W przypadku usterek lub awarii źródła światła prosimy o kontakt z firmą TRILUX.



**NOTICE.** Do not cover the product with insulating material.



**UWAGA!** Niebezpieczeństwo obrażeń! Elementy oprawy należy montować w rękawicach ochronnych.

**Ważne wskazówki dotyczące stateczników elektronicznych**

Przerwanie przewodu zerowego w obwodzie trójfazowym prowadzi do uszkodzenia instalacji oświetleniowej na skutek przepięcia. Zacisk rozłączny przewodu zerowego należy rozwierać tylko po odłączeniu od zasilania i zewrzeć go ponownie przed ponownym włączeniem. Nie przekraczać maksymalnej dopuszczalnej temperatury otoczenia tej oprawy. Przegrzanie skraca trwałość urządzenia, a w ekstremalnych przypadkach grozi przedwczesną awarią oprawy. Przewody podłączeniowe wejść sterujących urządzeń roboczych DALI (1...10 V, DALI itp.) muszą mieć izolację dopuszczoną do pracy pod napięciem 230 V (izolacja podstawowa).

**Zastosowanie zgodnie z przeznaczeniem**

Przeznaczona do eksploatacji w pomieszczeniach o temperaturze otoczenia maksymalna: **ta 25°C**

Klasa ochronności: I

Stopień ochrony: **IP20**

**Utylizacja zużytego sprzętu elektrycznego i elektronicznego**

Po zakończeniu okresu eksploatacji zużyte urządzenia elektryczne i elektroniczne należy zawsze zbierać i utylizować oddzielnie. W przypadku wątpliwości należy uzyskać informacje na temat przyjaznego dla środowiska usuwania odpadów od władz lokalnych lub firm zajmujących się utylizacją odpadów specjalnych. Aktualne informacje dotyczące klasy wydajności energetycznej wybranego wariantu produktu znaleźć można na odpowiedniej karcie katalogowej oprawy. Wskazówki dotyczące wymiany lub demontażu źródła światła zgodnie z rozporządzeniem UE 2019/2020 znaleźć można pod adresem:

[www.trilux.com/EcoDesign](http://www.trilux.com/EcoDesign)



# SOLVAN FLOW C CPI-I LED

Type	≈ kg
SFLOW C1...CDP-I...ET	3,6
SFLOW C1...CDP-I...ETDD	3,7
SFLOW C2...CDP-I...ET	4,4
SFLOW C2...CDP-I...ETDD	4,5
SFLOW ACT C2...CDP-I...ETDD8	4,6

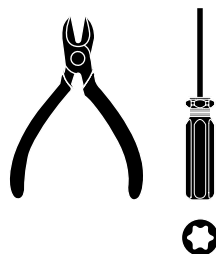
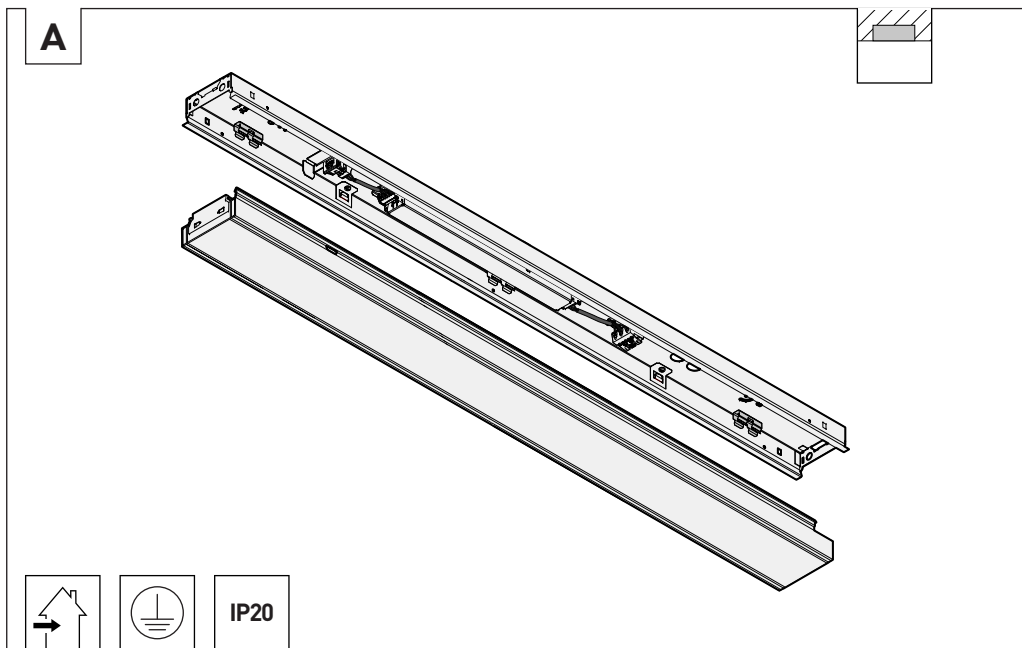

# SOLVAN FLOW C CDP-I LED



Type
SFLOW C1...CDP-I...ET
SFLOW C1...CDP-I...ETDD
SFLOW C2...CDP-I...ET
SFLOW C2...CDP-I...ETDD
SFLOW ACT C2...CDP-I...ETDD8

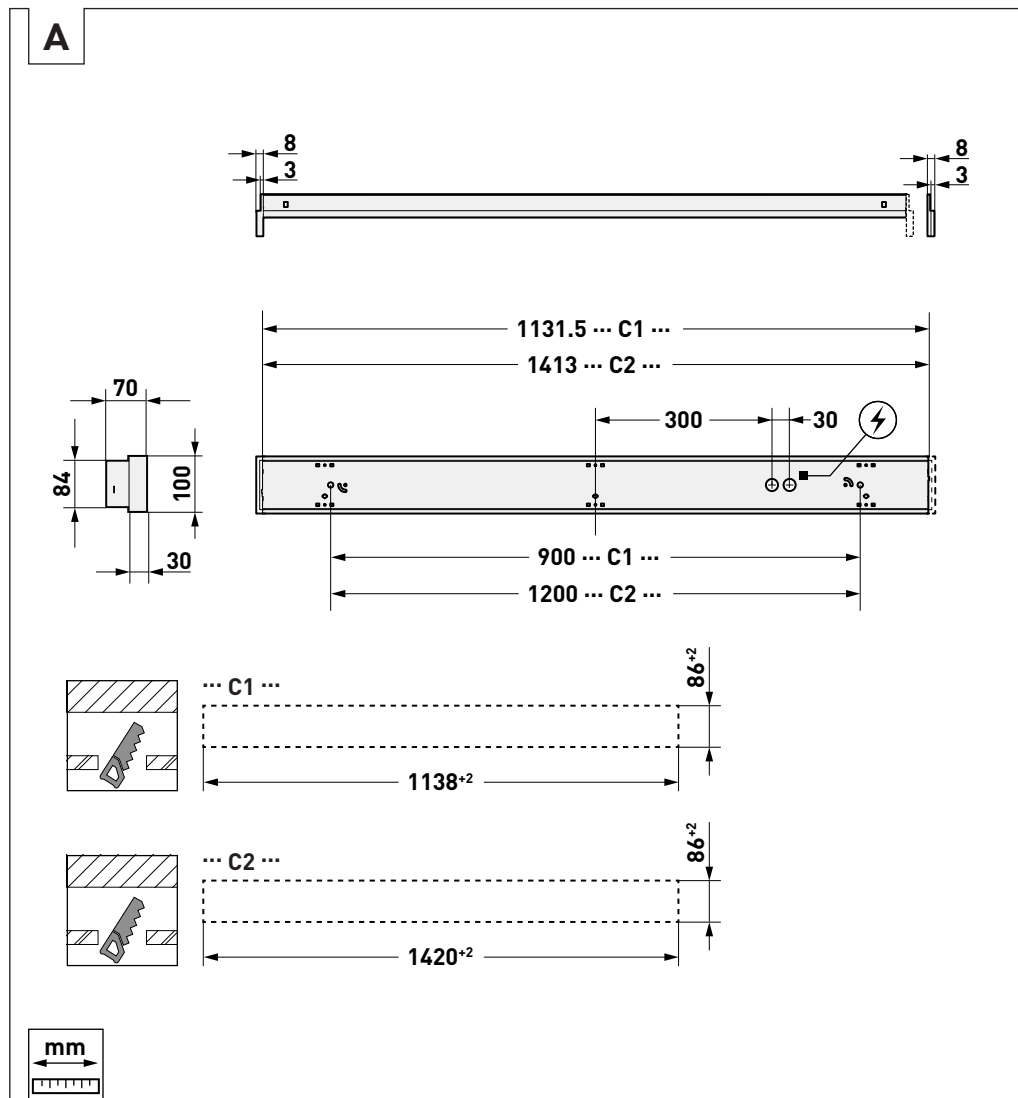



# SOLVAN FLOW C CPI-I LED

A

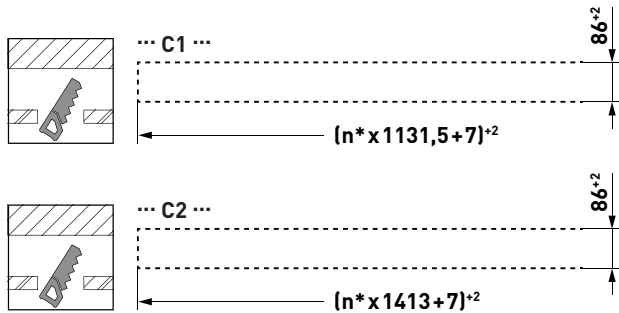
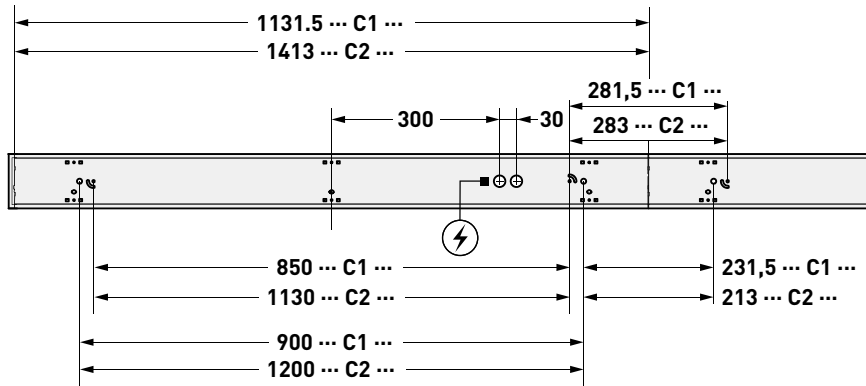
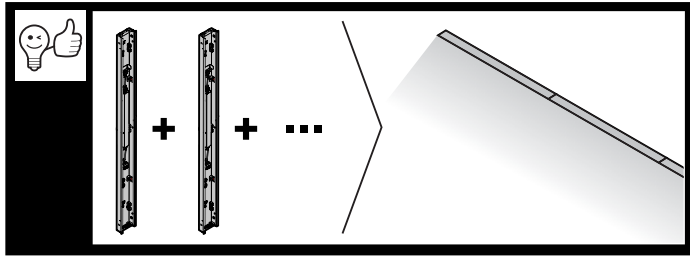

DE	Anzahl Leuchten	ES	Número de las luminarias	* n = ... C1...
EN	Number of luminaires	NL	Aantal armaturen	... C2...
FR	Nombre des luminaires	PL	Liczba opraw oświetleniowych	
IT	Numero di apparecchi			



# SOLVAN FLOW C CDP-I LED



A

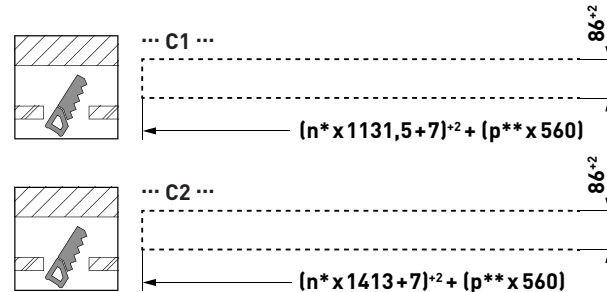
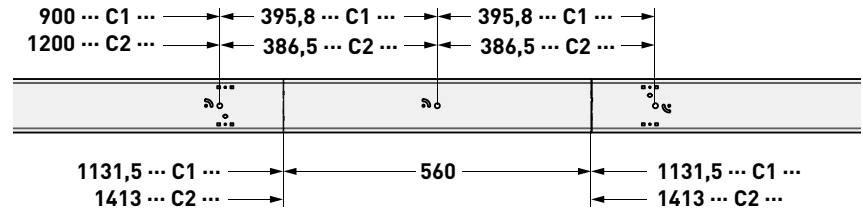
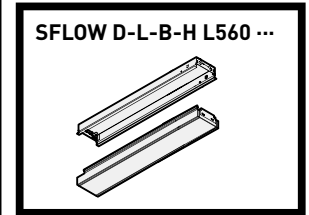
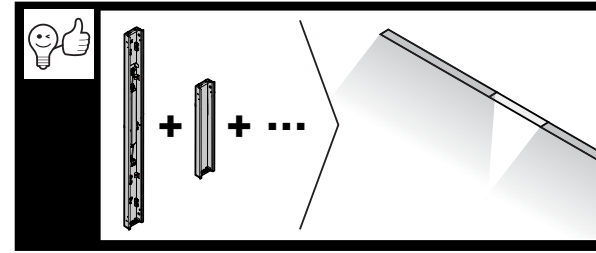

DE	Anzahl Leuchten	ES	Número de las luminarias	* n = ... C1...
EN	Number of luminaires	NL	Aantal armaturen	... C2...
FR	Nombre des luminaires	PL	Liczba opraw oświetleniowych	** p = Blind cover
IT	Numero di apparecchi			... C-L-B-H L560 ...





# SOLVAN FLOW C CPI-I LED

Type	≈ kg
SFLOW C3 ... CDP-I ... ETDD LLWM	4,4
SFLOW C3 ... CDP-I ... ETDD LLWS	4,4
SFLOW ACT C3 ... CDP-I ... ETDD8 LLWM	4,6
SFLOW ACT C3 ... CDP-I ... ETDD8 LLWS	4,5

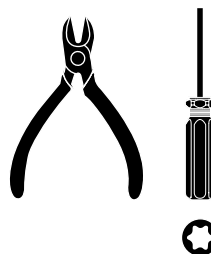
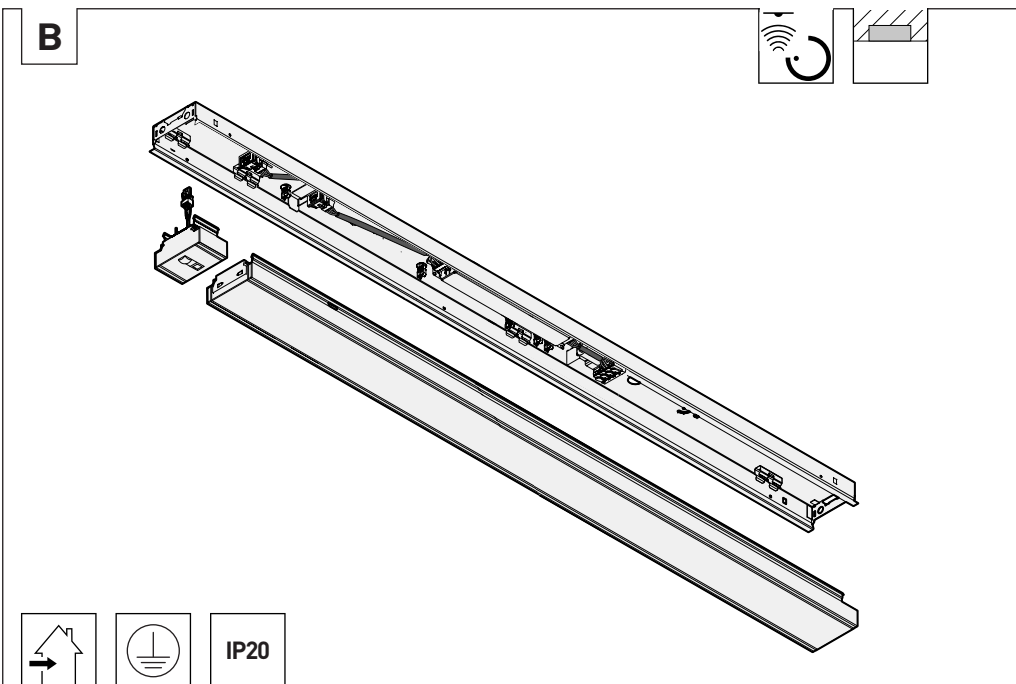

# SOLVAN FLOW C CDP-I LED



Type
SFLOW C3 ... CDP-I ... ETDD LLWM
SFLOW C3 ... CDP-I ... ETDD LLWS
SFLOW ACT C3 ... CDP-I ... ETDD8 LLWM
SFLOW ACT C3 ... CDP-I ... ETDD8 LLWS

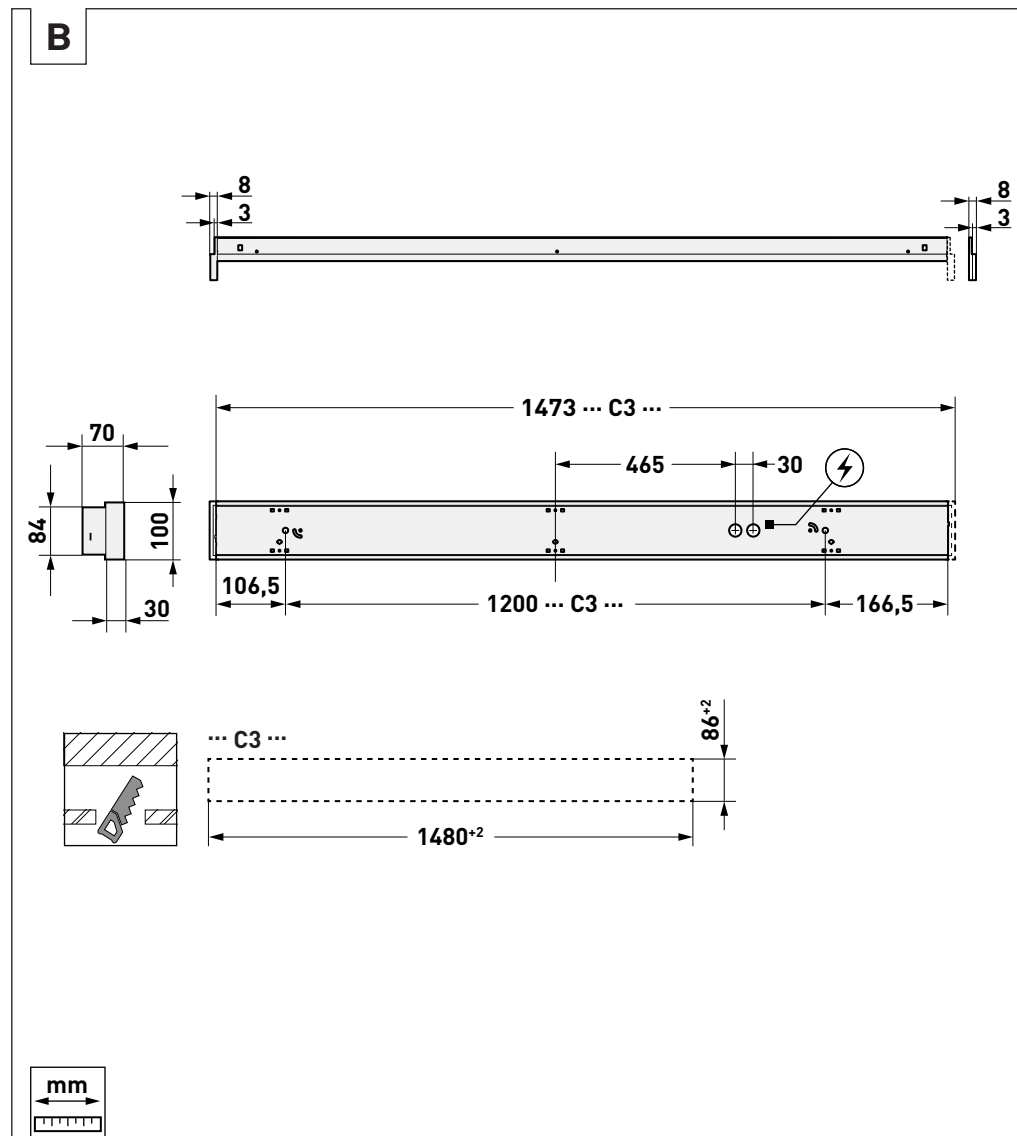





# SOLVAN FLOW C CPI-I LED

B

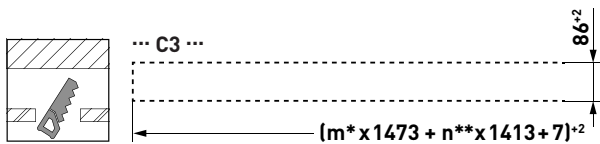
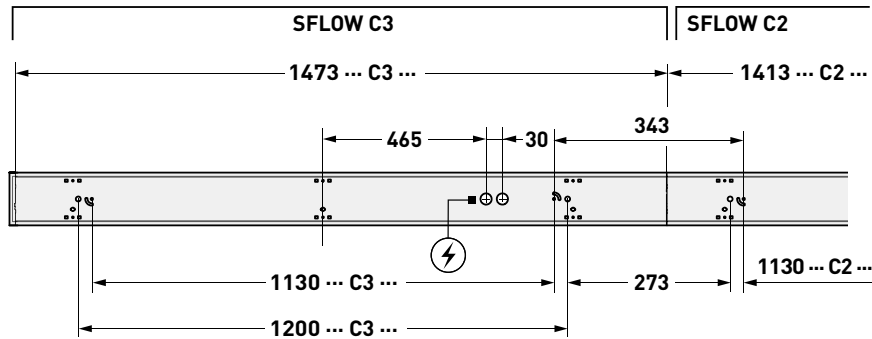
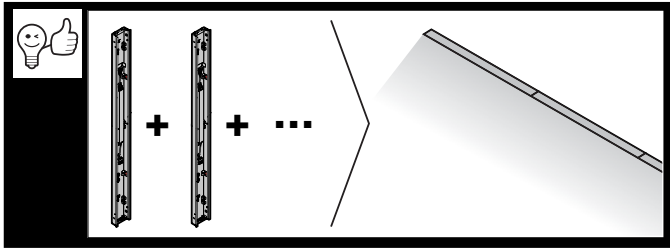

DE Anzahl Leuchten	ES Número de las luminarias	* m = ... C3 ... LL
EN Number of luminaires	NL Aantal armaturen	** n = ... C2 ... ETDD
FR Nombre des luminaires	PL Liczba opraw oświetleniowych	
IT Numero di apparecchi		



# SOLVAN FLOW C CDP-I LED



B

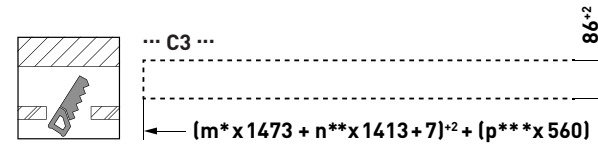
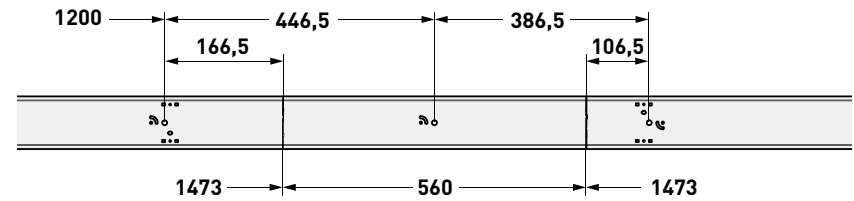
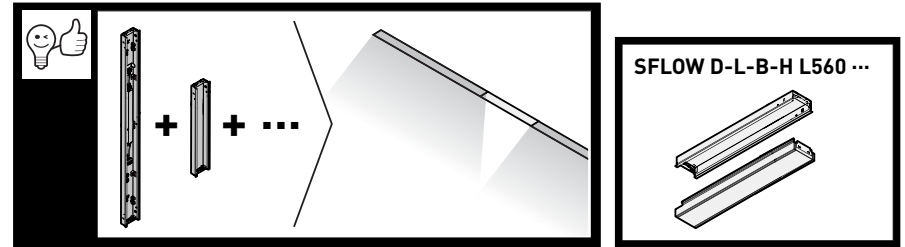

DE Anzahl Leuchten	ES Número de las luminarias	* m = ... C3 ... LL
EN Number of luminaires	NL Aantal armaturen	** n = ... C2 ... ETDD
FR Nombre des luminaires	PL Liczba opraw oświetleniowych	*** p = Blind cover ... C-L B-H L560 ...
IT Numero di apparecchi		





# SOLVAN FLOW C CPI-I LED

01

A B

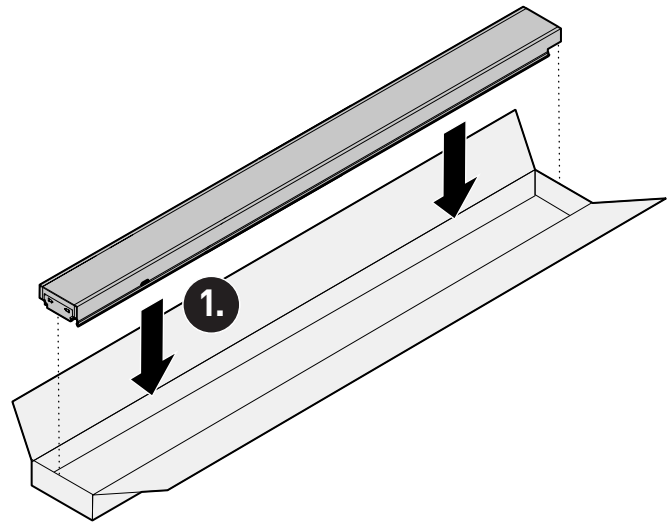

02

A B

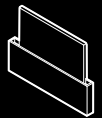

Type  
SFLOW C ZKS 01  
Toc  
75 133 00

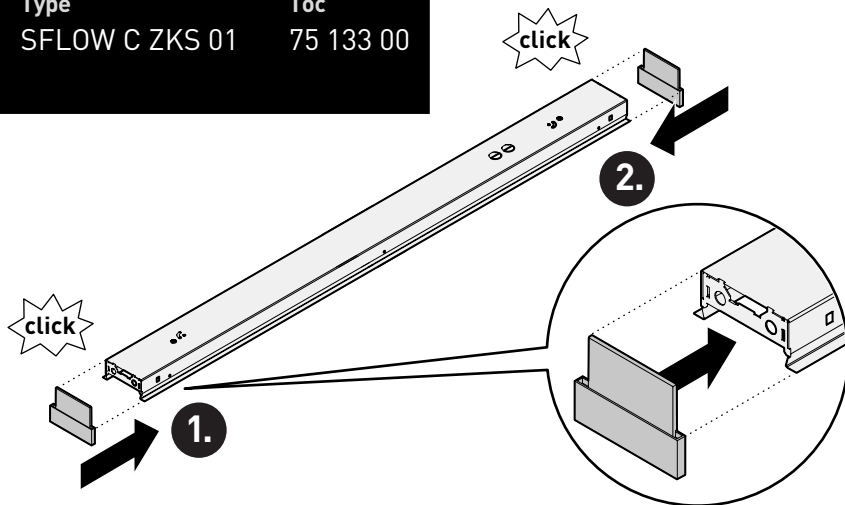

# SOLVAN FLOW C CDP-I LED



i

A B

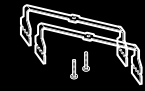

Type  
SFLOW ZBB  
Toc  
68 173 00



a

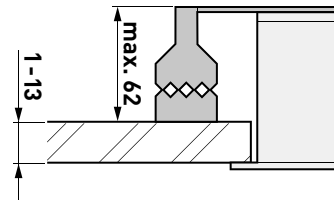

b

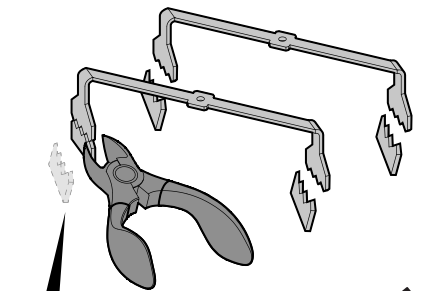
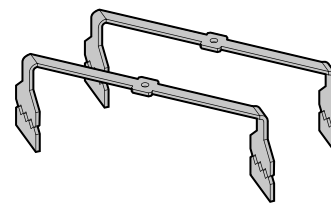
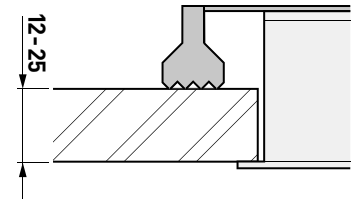



# SOLVAN FLOW C CPI-I LED

03

A B

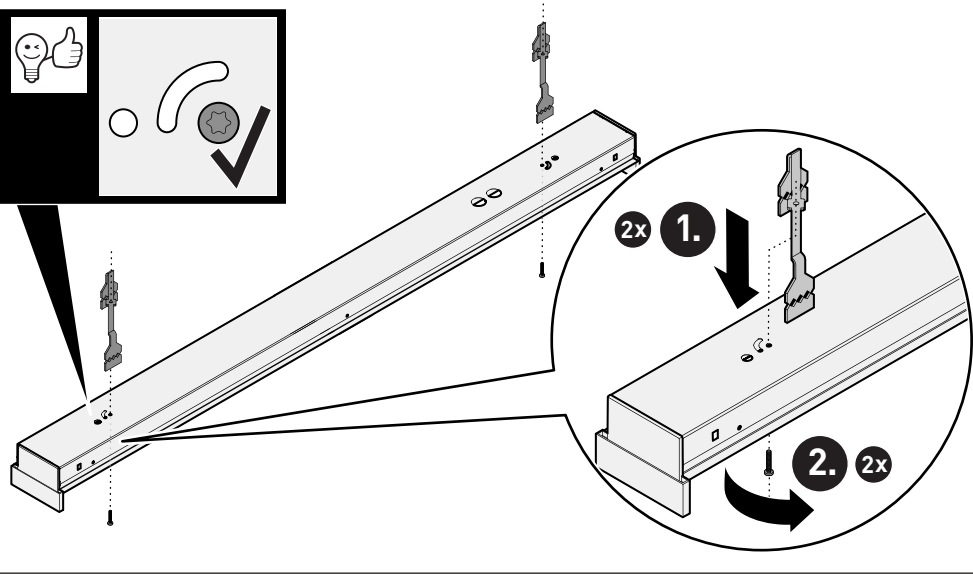
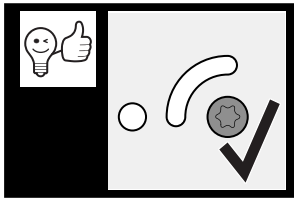

04

A B

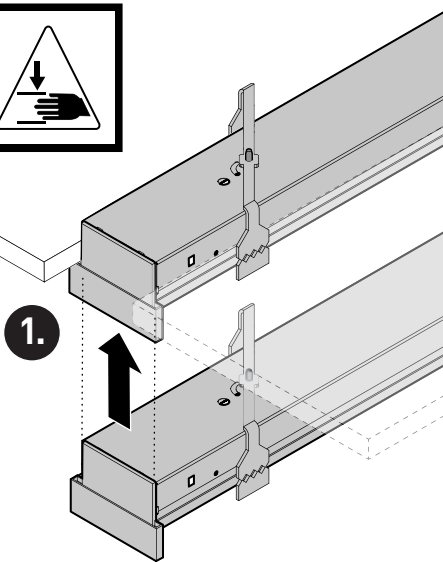

05

A B

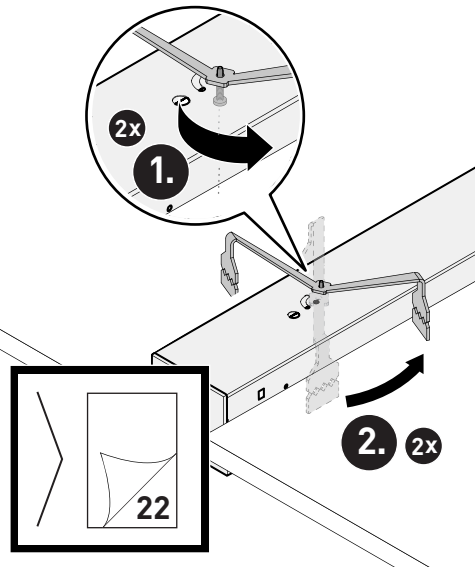

# SOLVAN FLOW C CDP-I LED

03

A B

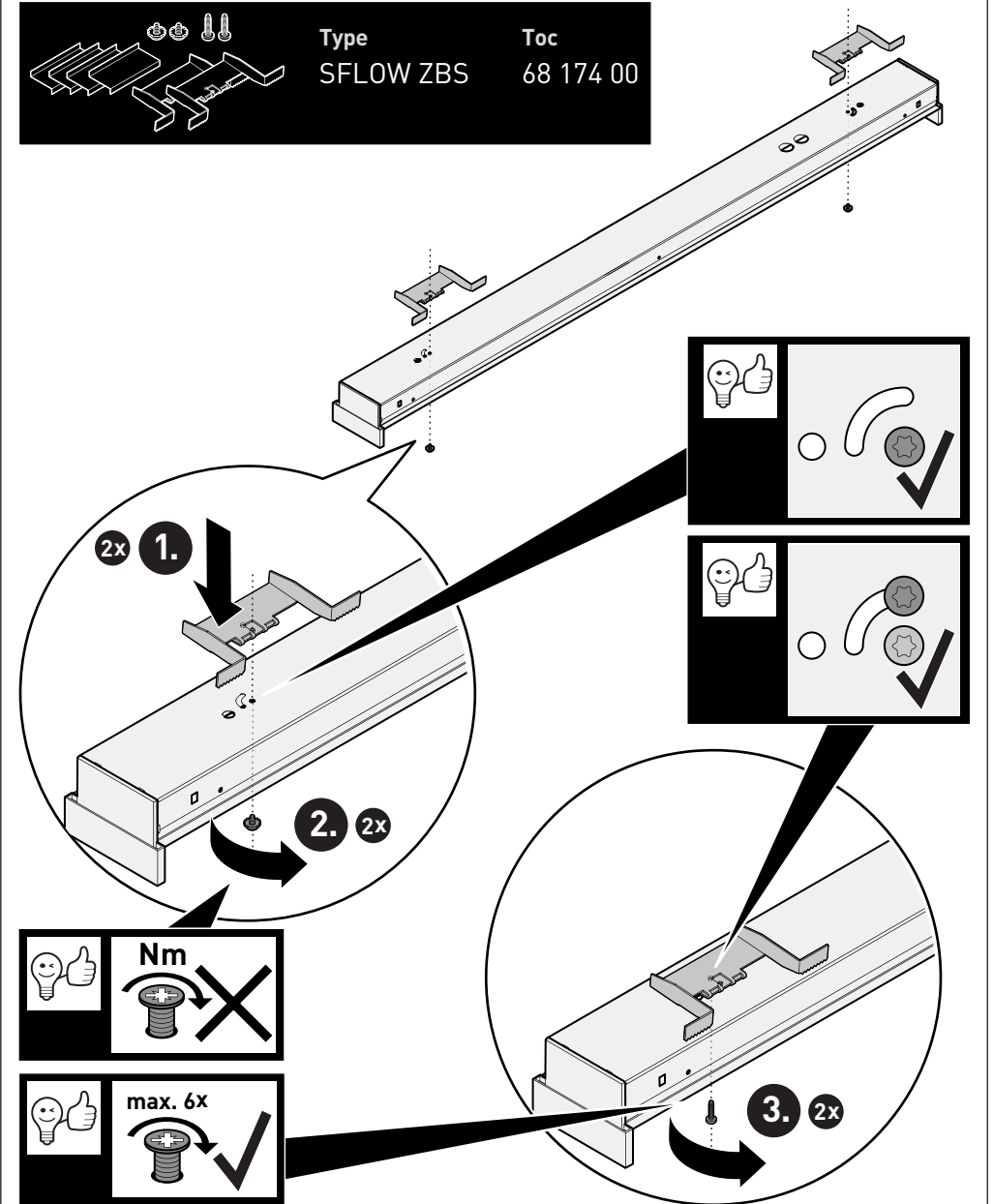
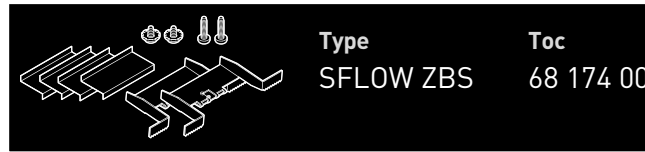



# SOLVAN FLOW C CPI-I LED

i A B

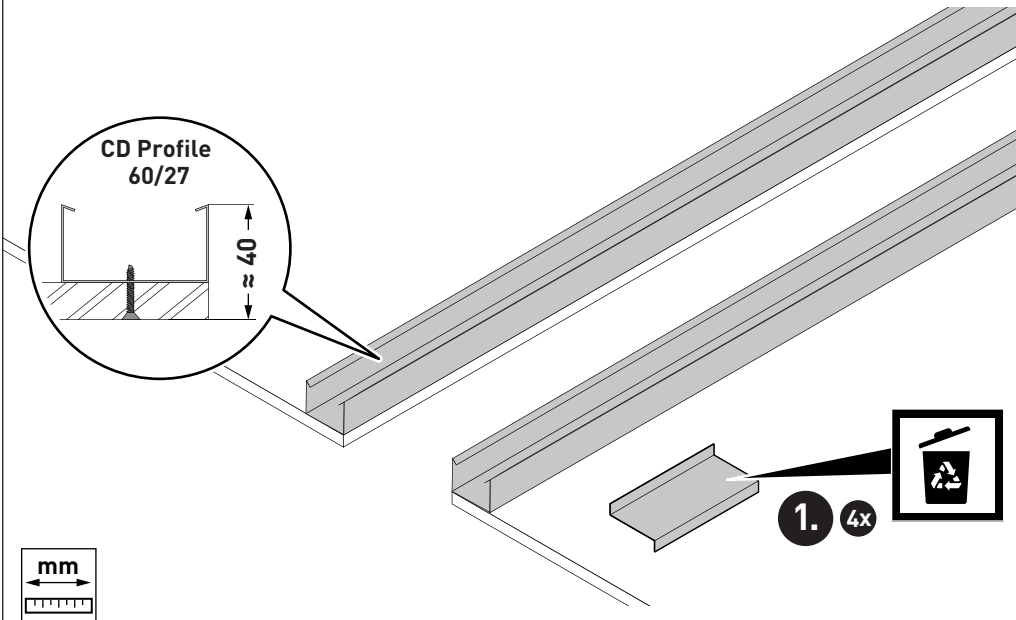
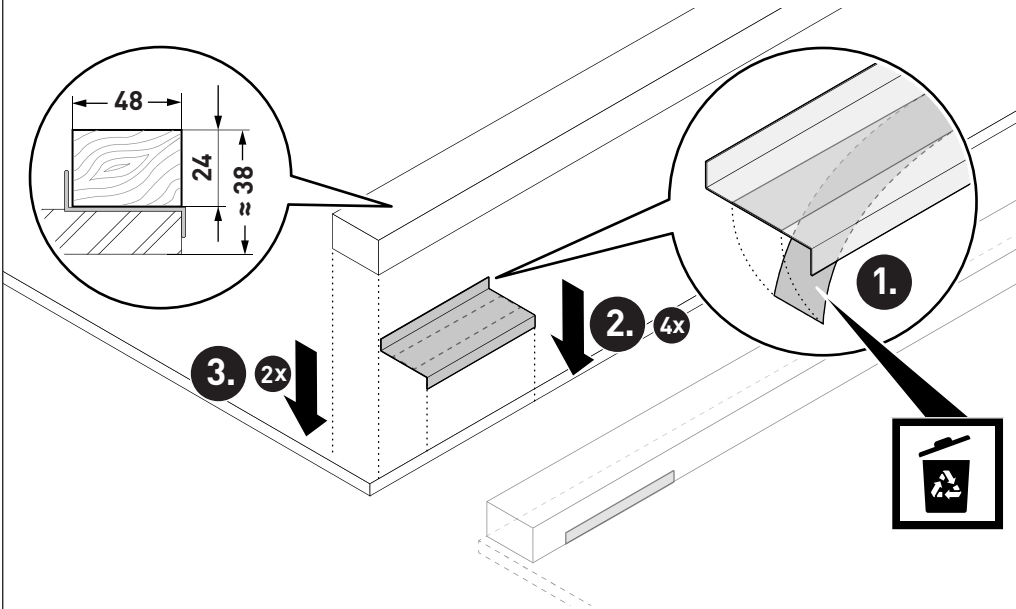

# SOLVAN FLOW C CDP-I LED

04 A B

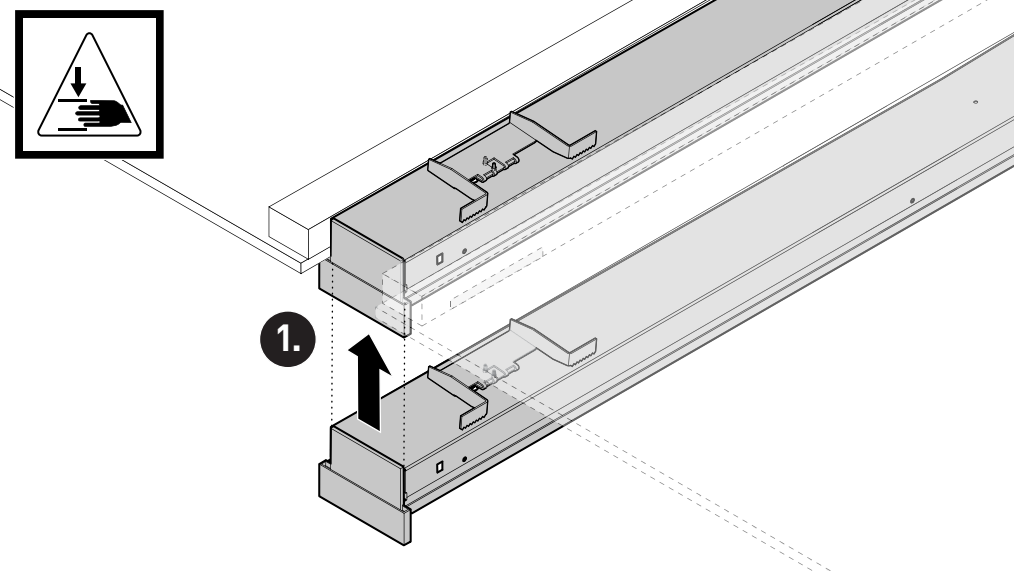

05 A B

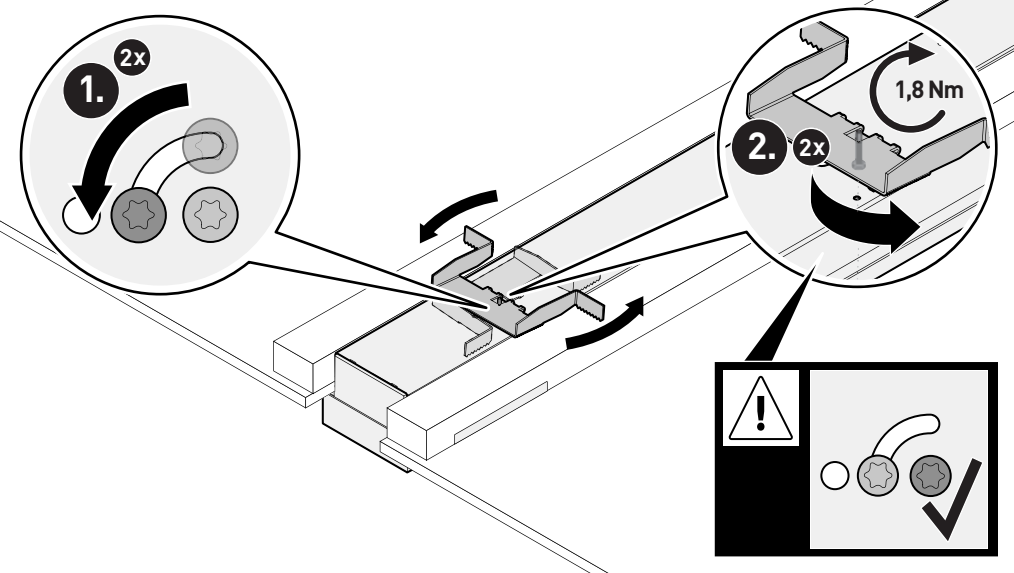



# SOLVAN FLOW C CPI-I LED

06

A B

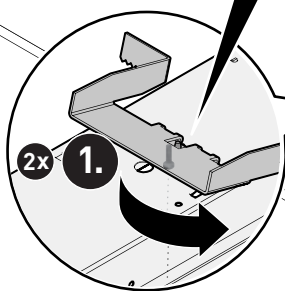
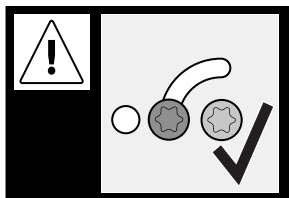

154



# SOLVAN FLOW C CDP-I LED

07

A B

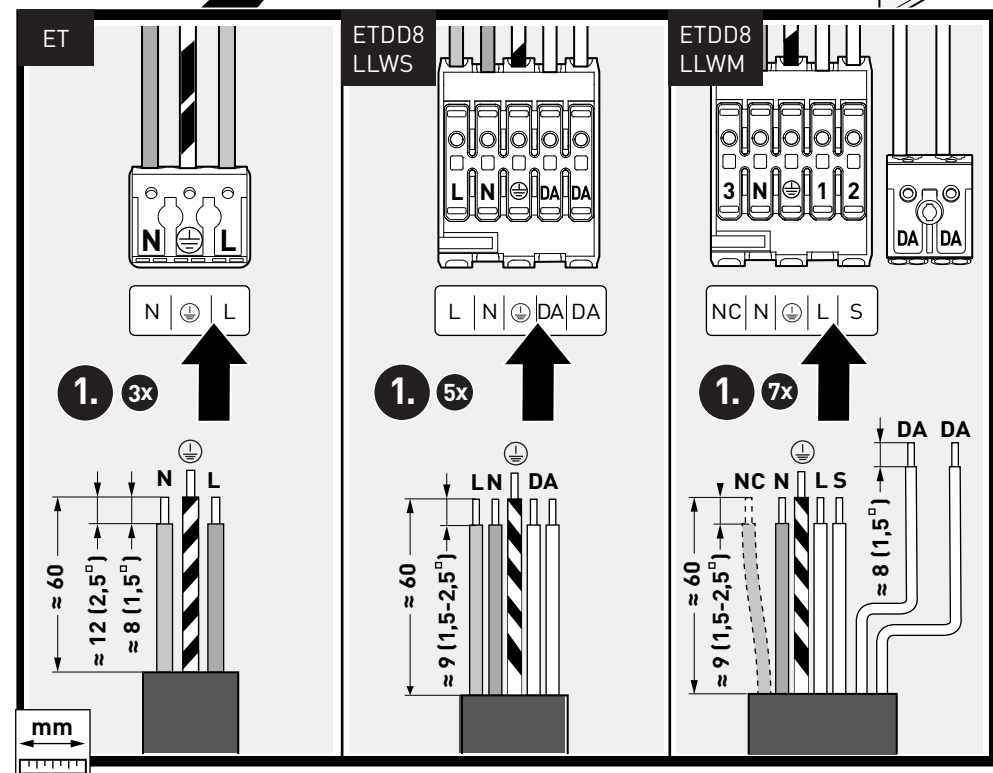
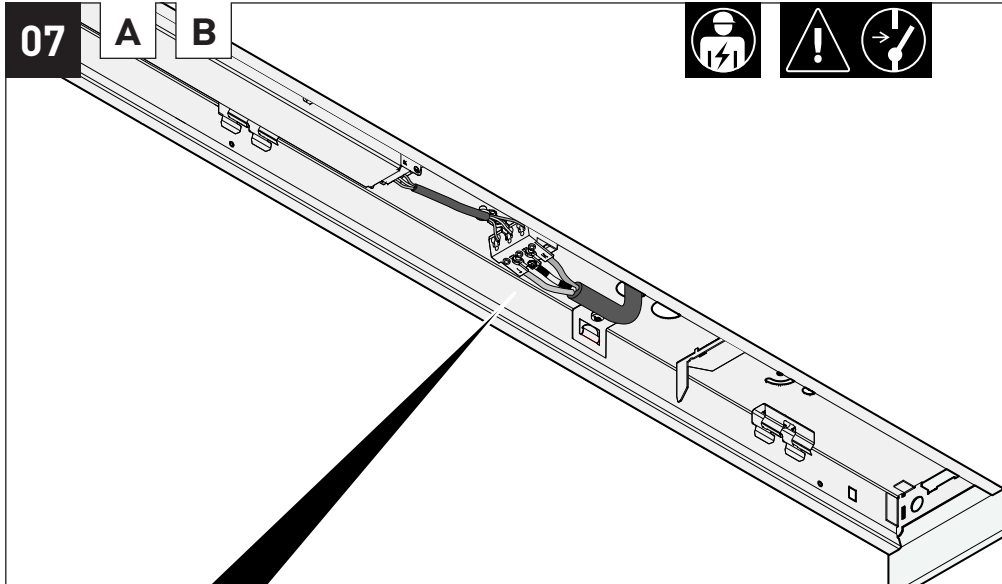



# SOLVAN FLOW C CPI-I LED

09

A

B

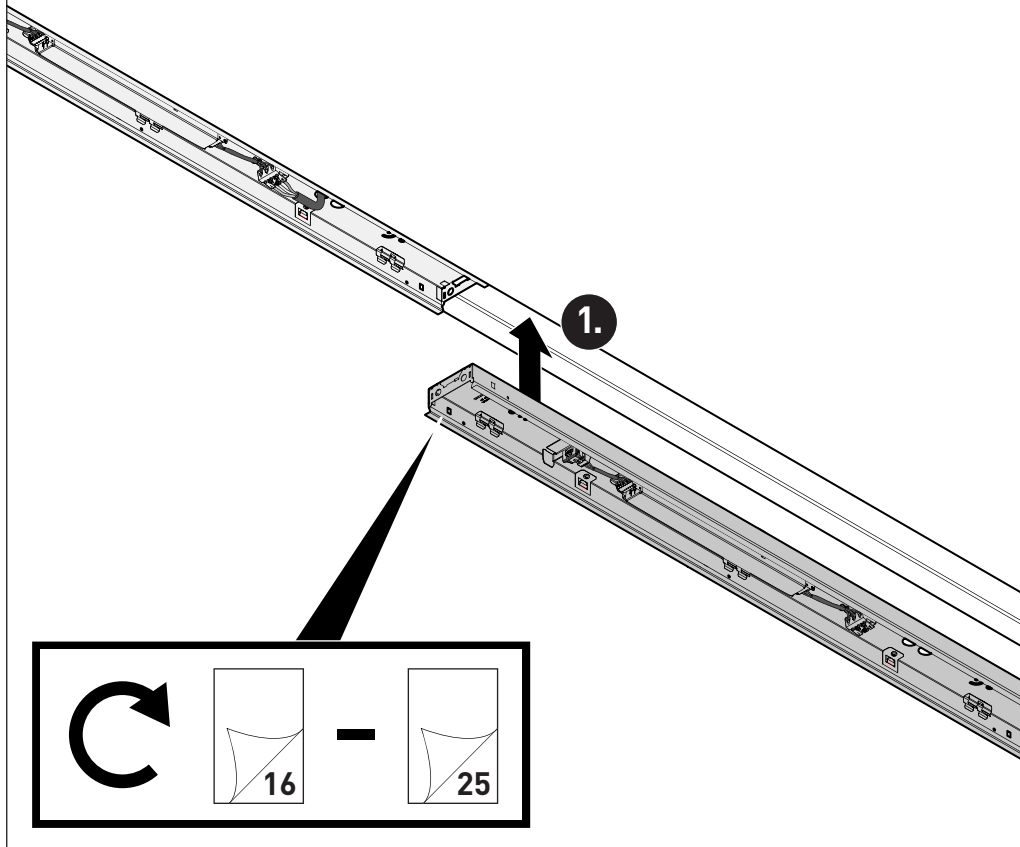
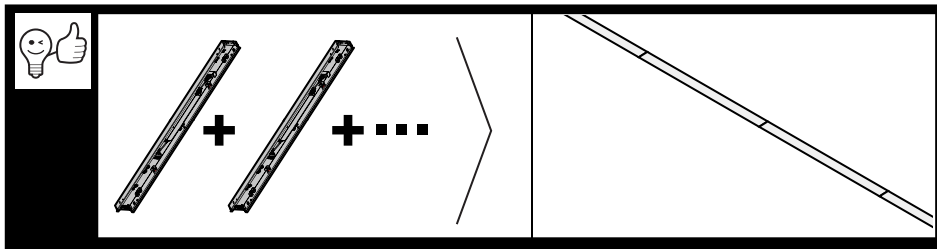

# SOLVAN FLOW C CDP-I LED

10

A

B

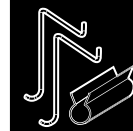

Type  
SFLOW C/D ZLK

Toc  
68 926 00

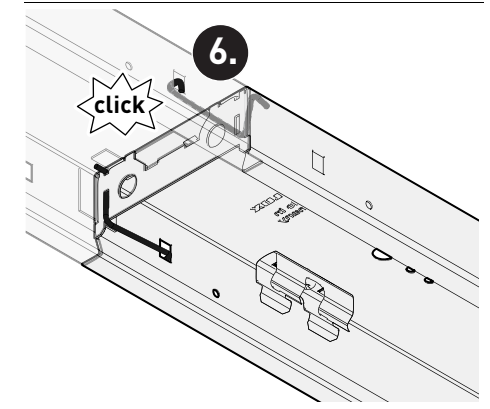
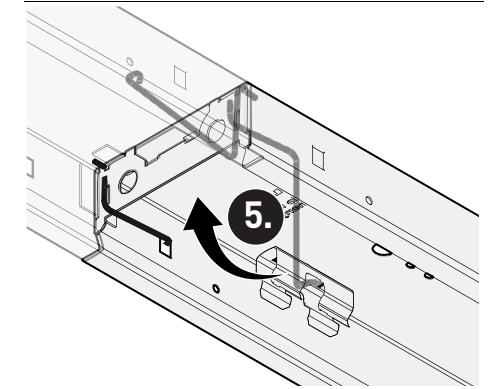
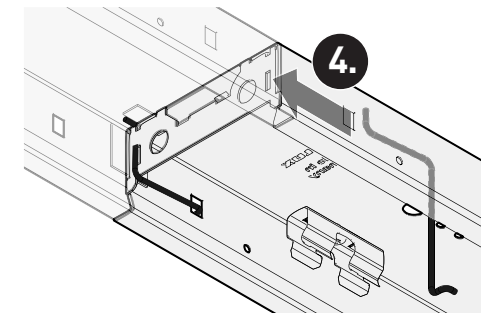
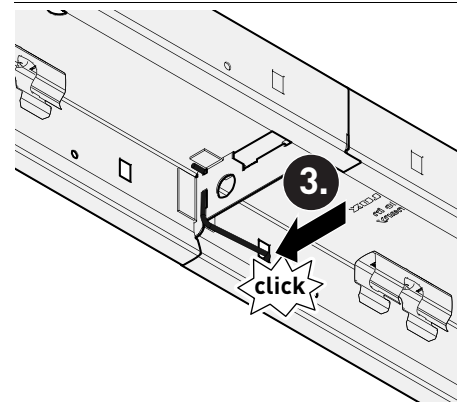
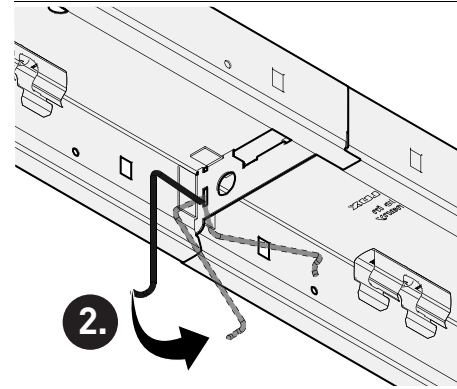
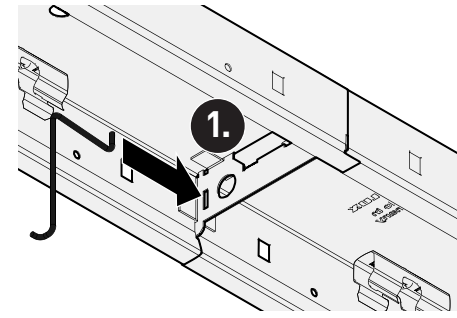
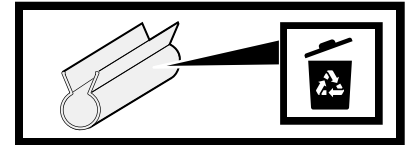



# SOLVAN FLOW C CPI-I LED

11

A B



Type	Toc
ZDV 315 L1	68 226 00
ZDV 315 L2	68 227 00
ZDV 515 L1	68 228 00
ZDV 515 L2	68 229 00
ZDV 515 LiveLink	69 189 00

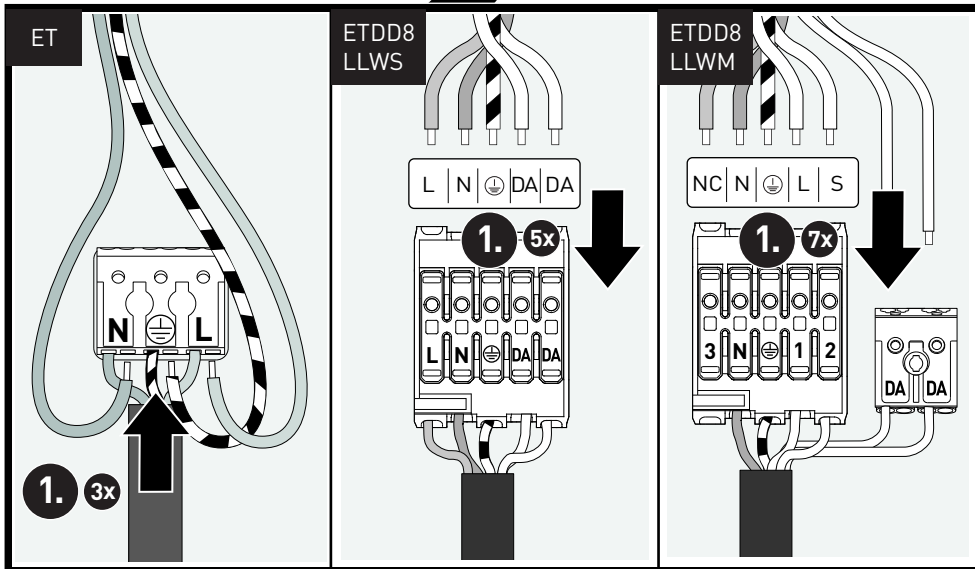
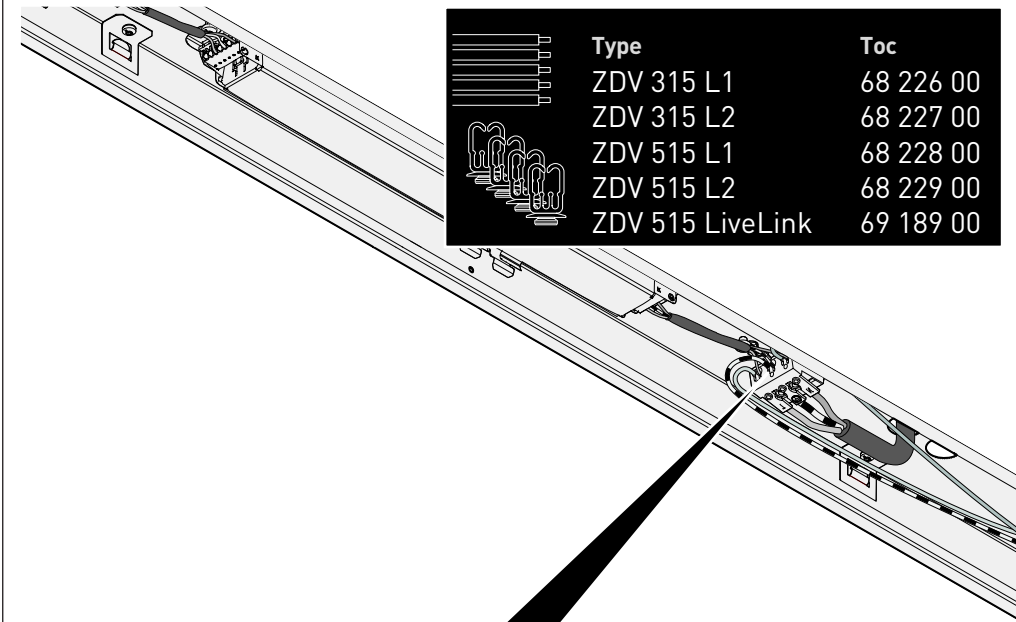

# SOLVAN FLOW C CDP-I LED



12

A B

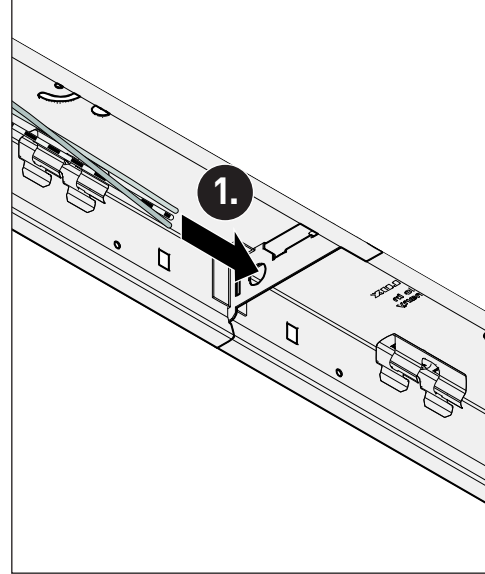

13

A B

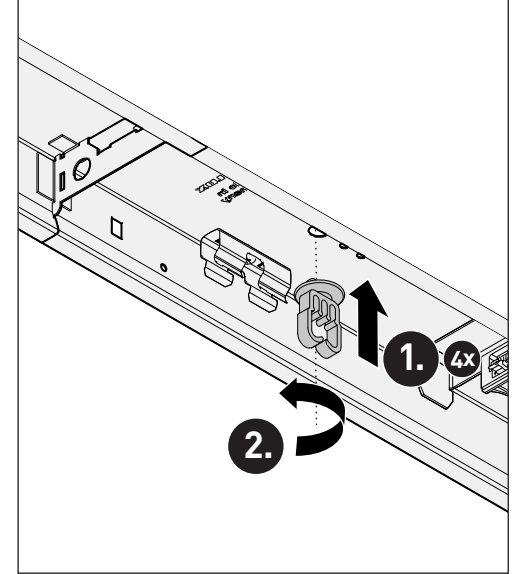

14

A B

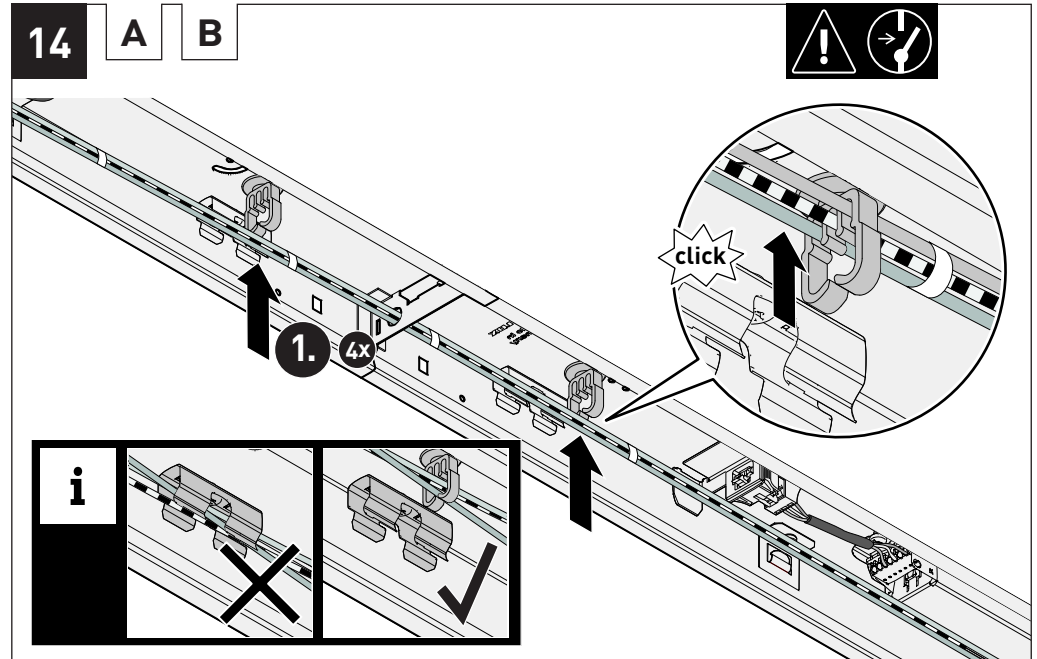



# SOLVAN FLOW C CPI-I LED

15

A B

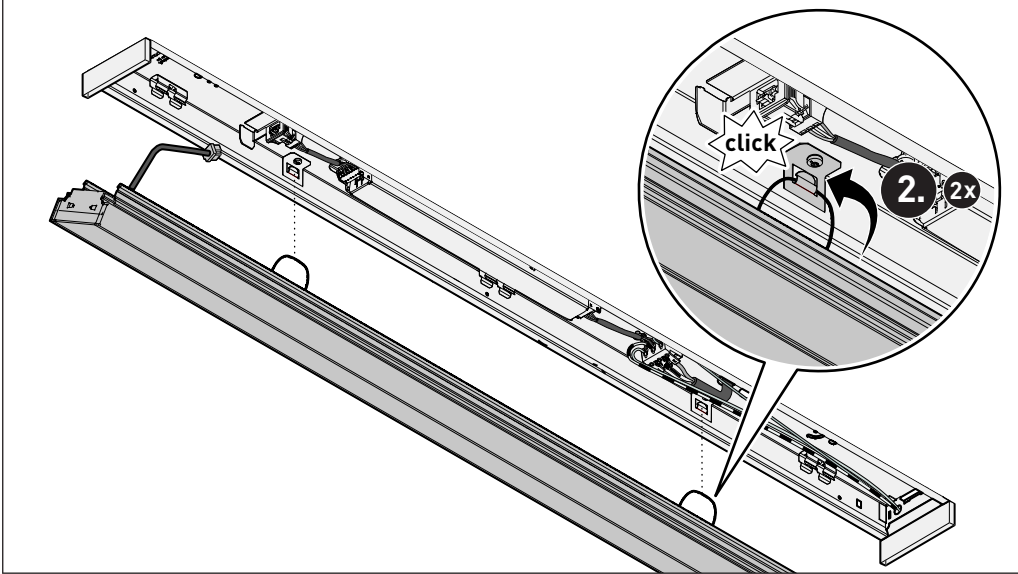

16

A

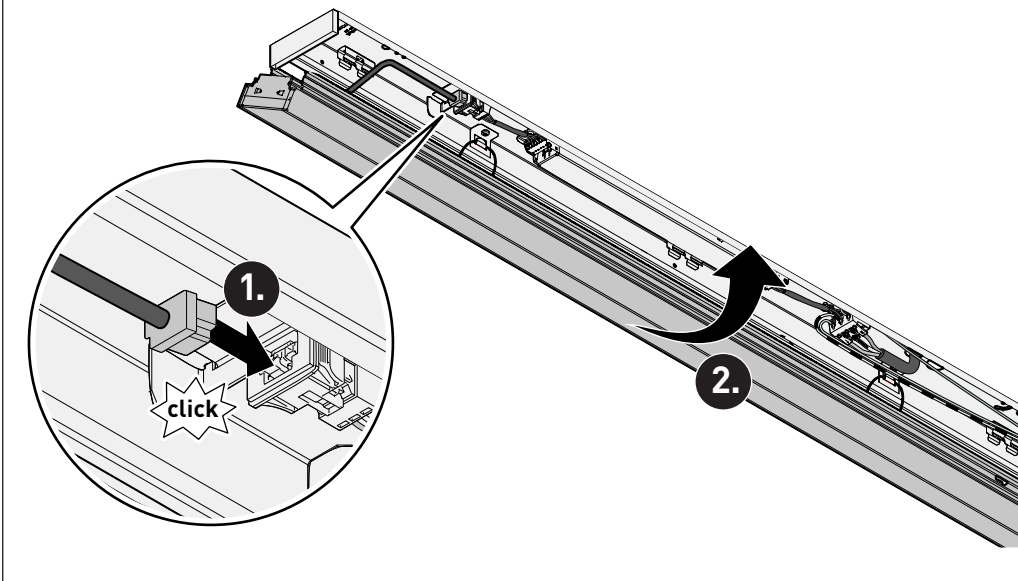

# SOLVAN FLOW C CDP-I LED

17

A

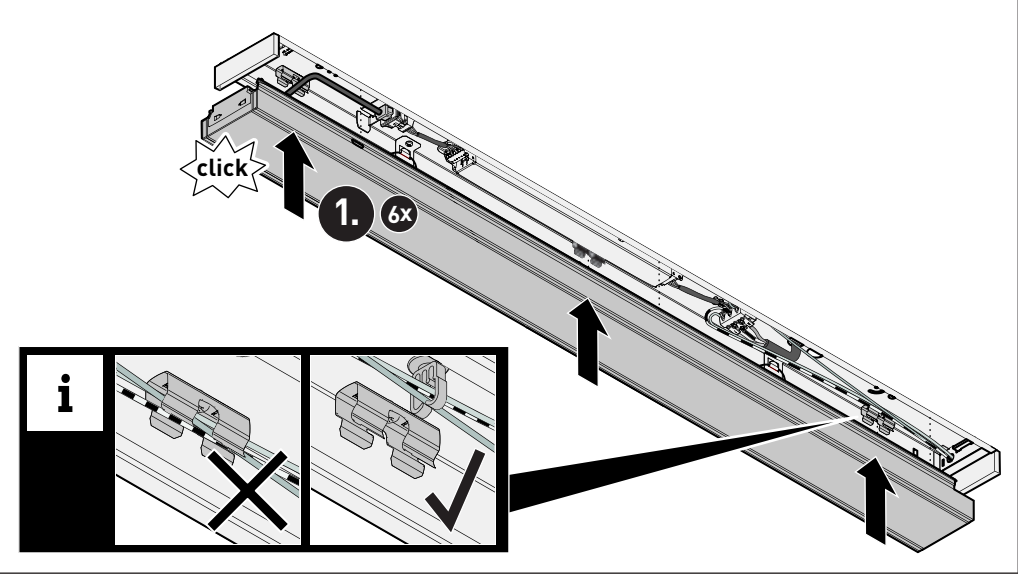

16

B

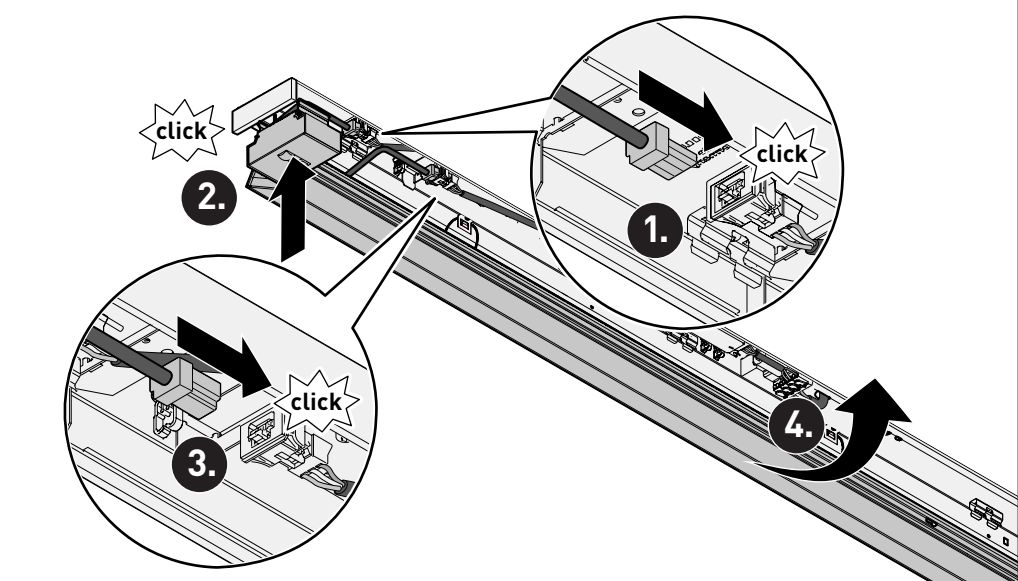





# SOLVAN FLOW C CPI-I LED

17

B

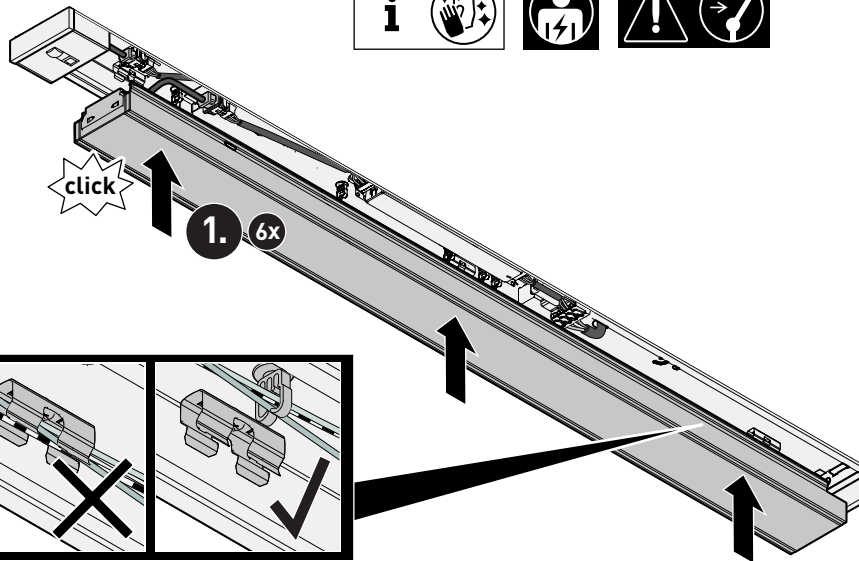

click

1. 6x

i

18

A

B

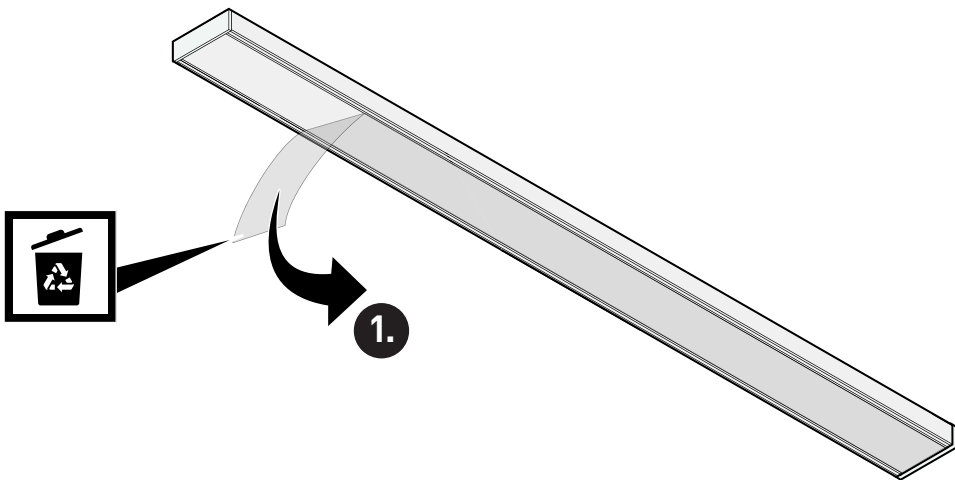

1.

# SOLVAN FLOW C CDP-I LED



19

A

B

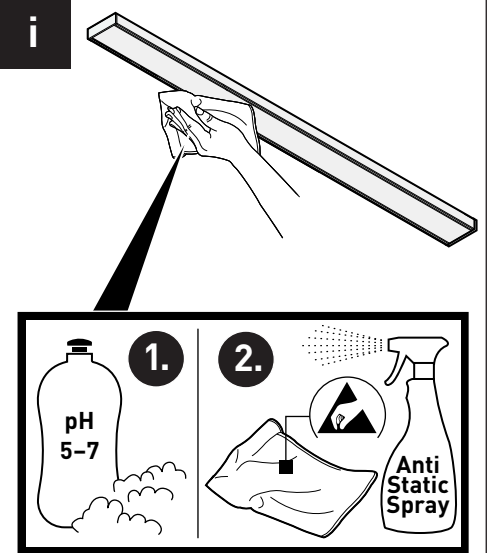
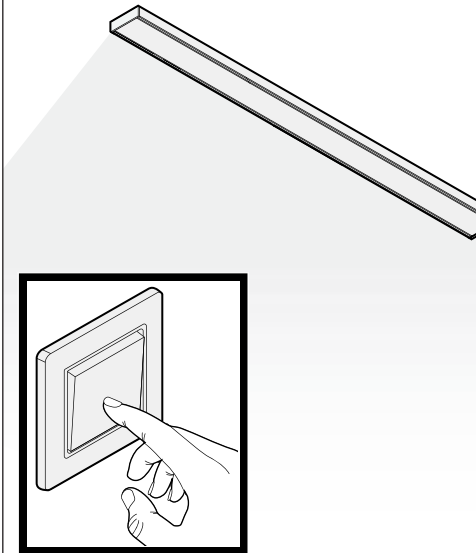

i

1.

2.

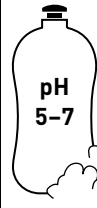

A

B

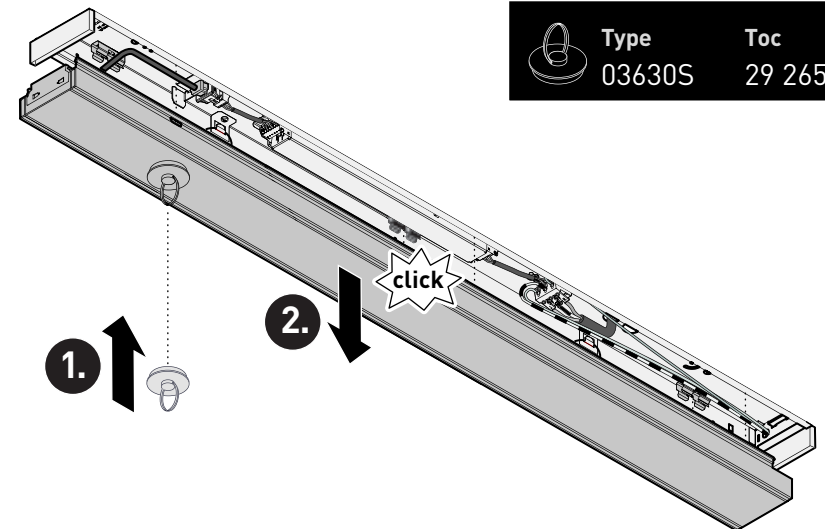

1.

2.

click



Type  
03630S

Toc  
29 265 00



TRILUX GmbH & Co. KG

Heidestraße  
D-59759 Arnsberg  
+49 2932 301-0  
info@trilux.com  
www.trilux.com