

SORAA LED Optical Light Engine

GaN-on-GaN™ Technology



SLE-16
(SLE30 heatsink)



SLC-30



SLE-30



SLE-16



SLC-16



SLE-11



SLC-11

Features

Soraa Point Source Optics™

Exceptional beam control from 9 degrees narrow spot to 36 degrees flood with smooth uniform light distributions

Soraa VP₃ Vivid Color™ and VP₃ Natural White™

Accurate color rendering and white rendering based on light emission across the full visible range from 400nm to 700nm

Soraa SNAP System™ Compatible

Narrow spot versions compatible with Soraa SNAP for flexible light distribution adjustment and white point change

Integrated Temperature Sensor

Reference point temperature readout enables in situ, in fixture temperature assessment

Qualification

UL8750 recognized

CE, RoHS

Projected Lifetime

50,000 hours to L70 and color stability based on CCT, at specified operating conditions. Projections based on LM-80 testing.

- 2700K - 0.007 du'v'

- 3000K - 0.007 du'v'

- 4000K - 0.009 du'v'

- Typical du'v' within field angle = 0.006

- Typical dCCT within the field angle (2700K and 3000K) = 150K

- Typical dCCT within the field angle (4000K) = 250K

SORAA*

Note: This specification sheet covers both SLE (with heatsink) and SLC (without heatsink) products. The

Product Performance Parameters

SLE30

Reference Number	CCT (K)	CRI	Beam angle	Field angle	Optimal Drive Current (mA)	Peak Intensity (Cd)	Nominal power consumption (W)	Luminous Flux (lm)	SNAP compatible
SLx30									
SLE30-04-004D-927-03-01	2,700K	95	4	9	175	9570	4.9	265	Yes
SLE30-08-009D-927-03-01	2,700K	95	9	16	580	20900	16.1	950	Yes
SLE30-08-025D-927-03-01	2,700K	95	25	40	580	5510	16.1	950	
SLE30-08-036D-927-03-01	2,700K	95	36	60	580	2660	16.1	950	
SLE30-04-004D-930-03-01	3,000K	95	4	9	175	10080	4.9	280	Yes
SLE30-08-009D-930-03-01	3,000K	95	9	16	580	22000	16.1	1000	Yes
SLE30-08-025D-930-03-01	3,000K	95	25	40	580	5800	16.1	1000	
SLE30-08-036D-930-03-01	3,000K	95	36	60	580	2800	16.1	1000	
SLE30-08-009D-940-03-01	4,000K	95	9	16	580	23100	16.1	1050	Yes
SLE30-08-025D-940-03-01	4,000K	95	25	40	580	6090	16.1	1050	
SLE30-08-036D-940-03-01	4,000K	95	36	60	580	2940	16.1	1050	
SLE30-04-004D-827-03-01	2,700K	80	4	9	175	11970	4.9	330	Yes
SLE30-08-009D-827-03-01	2,700K	80	9	16	580	26120	16.1	1185	Yes
SLE30-08-025D-827-03-01	2,700K	80	25	40	580	6880	16.1	1185	
SLE30-08-036D-827-03-01	2,700K	80	36	60	580	3320	16.1	1185	
SLE30-04-004D-830-03-01	3,000K	80	4	9	175	12600	4.9	350	Yes
SLE30-08-009D-830-03-01	3,000K	80	9	16	580	27500	16.1	1250	Yes
SLE30-08-025D-830-03-01	3,000K	80	25	40	580	7250	16.1	1250	
SLE30-08-036D-830-03-01	3,000K	80	36	60	580	3500	16.1	1250	

Notes:

1. The rated driving currents are for reference only: they lead to a lifetime of 50,000 hrs when used with the heatsink specified, at free air and 25°C ambient. The Light Engines must be tested thermally inside a fixture, to ensure they work at the desired temperature. Performance, lifetime and warranty are subject to the engine's working and storage temperature, and driving current. For the specific current-temperature combinations, consult the Application Guide.
2. Beam angle defined at 50% of peak intensity
3. Field angle defined at 10% of peak intensity



SORAA[®]

Product Performance Parameters

SLE16

Reference Number	CCT (K)	CRI	Beam angle	Field angle	Optimal Drive Current (mA)	Peak Intensity (Cd)	Nominal power consumption (W)	Luminous Flux (lm)	SNAP compatible
SLE16									
SLE16-06-010D-927-03-01	2,700K	95	10	20	290	6370	8.1	435	Yes
SLE16-08-015D-927-03-01	2,700K	95	15	30	440	5940	12.2	680	Yes
SLE16-08-025D-927-03-01	2,700K	95	25	40	440	3960	12.2	680	
SLE16-08-036D-927-03-01	2,700K	95	36	60	440	1900	12.2	680	
SLE16-06-010D-930-03-01	3,000K	95	10	20	290	6710	8.1	460	Yes
SLE16-08-015D-930-03-01	3,000K	95	15	30	440	6260	12.2	720	Yes
SLE16-08-025D-930-03-01	3,000K	95	25	40	440	4170	12.2	720	
SLE16-08-036D-930-03-01	3,000K	95	36	60	440	2010	12.2	720	
SLE16-06-010D-940-03-01	4,000K	95	10	20	290	7040	8.1	480	Yes
SLE16-08-015D-940-03-01	4,000K	95	15	30	440	6570	12.2	755	Yes
SLE16-08-025D-940-03-01	4,000K	95	25	40	440	4370	12.2	755	
SLE16-08-036D-940-03-01	4,000K	95	36	60	440	2110	12.2	755	
SLE16-06-010D-827-03-01	2,700K	80	10	20	290	7960	8.1	545	Yes
SLE16-08-015D-827-03-01	2,700K	80	15	30	440	7430	12.2	855	Yes
SLE16-08-025D-827-03-01	2,700K	80	25	40	440	4950	12.2	855	
SLE16-08-036D-827-03-01	2,700K	80	36	60	440	2380	12.2	855	
SLE16-06-010D-830-03-01	3,000K	80	10	20	290	8380	8.1	575	Yes
SLE16-08-015D-830-03-01	3,000K	80	15	30	440	7820	12.2	900	Yes
SLE16-08-025D-830-03-01	3,000K	80	25	40	440	5210	12.2	900	
SLE16-08-036D-830-03-01	3,000K	80	36	60	440	2510	12.2	900	

Notes:

1. The rated driving currents are for reference only: they lead to a lifetime of 50,000 hrs when used with the heatsink specified, at free air and 25°C ambient. The Light Engines must be tested thermally inside a fixture, to ensure they work at the desired temperature. Performance, lifetime and warranty are subject to the engine's working and storage temperature, and driving current. For the specific current-temperature combinations, consult the Application Guide.
2. Beam angle defined at 50% of peak intensity
3. Field angle defined at 10% of peak intensity



SORAA[®]

Product Performance Parameters

SLE16 with larger SLE30 heatsink

Reference Number	CCT (K)	CRI	Beam angle	Field angle	Optimal Drive Current (mA)	Peak Intensity (Cd)	Nominal power consumption (W)	Luminous Flux (lm)	SNAP compatible
SLE16 (with SLE30 heatsink)									
SLE16-06-010D-927-03-03	2,700K	95	10	20	370	7480	10.3	510	Yes
SLE16-08-015D-927-03-03	2,700K	95	15	30	580	7600	16.1	870	Yes
SLE16-08-025D-927-03-03	2,700K	95	25	40	580	5510	16.1	950	
SLE16-08-036D-927-03-03	2,700K	95	36	60	580	2660	16.1	950	
SLE16-06-010D-930-03-03	3,000K	95	10	20	370	7880	10.3	540	Yes
SLE16-08-015D-930-03-03	3,000K	95	15	30	580	8000	16.1	920	Yes
SLE16-08-025D-930-03-03	3,000K	95	25	40	580	5800	16.1	1000	
SLE16-08-036D-930-03-03	3,000K	95	36	60	580	2800	16.1	1000	
SLE16-06-010D-940-03-03	4,000K	95	10	20	370	8270	10.3	565	Yes
SLE16-08-015D-940-03-03	4,000K	95	15	30	580	8400	16.1	965	Yes
SLE16-08-025D-940-03-03	4,000K	95	25	40	580	6090	16.1	1050	
SLE16-08-036D-940-03-03	4,000K	95	36	60	580	2940	16.1	1050	
SLE16-06-010D-827-03-03	2,700K	80	10	20	370	9350	10.3	640	Yes
SLE16-08-015D-827-03-03	2,700K	80	15	30	580	9500	16.1	1090	Yes
SLE16-08-025D-827-03-03	2,700K	80	25	40	580	6880	16.1	1185	
SLE16-08-036D-827-03-03	2,700K	80	36	60	580	3320	16.1	1185	
SLE16-06-010D-830-03-03	3,000K	80	10	20	370	9850	10.3	675	Yes
SLE16-08-015D-830-03-03	3,000K	80	15	30	580	10000	16.1	1150	Yes
SLE16-08-025D-830-03-03	3,000K	80	25	40	580	7250	16.1	1250	
SLE16-08-036D-830-03-03	3,000K	80	36	60	580	3500	16.1	1250	

Notes:

1. The rated driving currents are for reference only: they lead to a lifetime of 50,000 hrs when used with the heatsink specified, at free air and 25°C ambient. The Light Engines must be tested thermally inside a fixture, to ensure they work at the desired temperature. Performance, lifetime and warranty are subject to the engine's working and storage temperature, and driving current. For the specific current-temperature combinations, consult the Application Guide.
2. Beam angle defined at 50% of peak intensity
3. Field angle defined at 10% of peak intensity



SORAA*

Product Performance Parameters

SLE11

Reference Number	CCT (K)	CRI	Beam angle	Field angle	Optimal Drive Current (mA)	Peak Intensity (Cd)	Nominal power consumption (W)	Luminous Flux (lm)	SNAP compatible
SLE11									
SLE11-06-025D-927-03-01	2,700K	95	25	40	240	2360	6.7	405	
SLE11-06-036D-927-03-01	2,700K	95	36	60	240	1140	6.7	405	
SLE11-06-025D-930-03-01	3,000K	95	25	40	240	2490	6.7	430	
SLE11-06-036D-930-03-01	3,000K	95	36	60	240	1200	6.7	430	
SLE11-06-025D-940-03-01	4,000K	95	25	40	240	2610	6.7	450	
SLE11-06-036D-940-03-01	4,000K	95	36	60	240	1260	6.7	450	
SLE11-06-025D-827-03-01	2,700K	80	25	40	240	2950	6.7	510	
SLE11-06-036D-827-03-01	2,700K	80	36	60	240	1420	6.7	510	
SLE11-06-025D-830-03-01	3,000K	80	25	40	240	3110	6.7	535	
SLE11-06-036D-830-03-01	3,000K	80	36	60	240	1500	6.7	535	

Notes:

1. The rated driving currents are for reference only: they lead to a lifetime of 50,000 hrs when used with the heatsink specified, at free air and 25°C ambient. The Light Engines must be tested thermally inside a fixture, to ensure they work at the desired temperature. Performance, lifetime and warranty are subject to the engine's working and storage temperature, and driving current. For the specific current-temperature combinations, consult the Application Guide.
2. Beam angle defined at 50% of peak intensity
3. Field angle defined at 10% of peak intensity



Electrical Characteristics

Product part number	Maximum Current (mA)	Maximum Tcase (°C)
SLE30-04-004D-xxx-xx-xx	188	100
SLE30-08-xxxD-xxx-xx-xx	750	100
SLE16-08-xxxD-xxx-xx-03	750	100
SLE16-08-xxxD-xxx-xx-01	750	100
SLE16-06-xxxD-xxx-xx-03	375	100
SLE16-06-xxxD-xxx-xx-01	375	100
SLE11-06-xxxD-xxx-xx-xx	375	100

Notes:

- Forward voltage depends on drive current and temperature. For driver selection a supportable range of 20V to 35V is recommended.
- Dimming can be achieved with Pulse Width Modulation and Current Amplitude Modulation or a combination of both.

Typical Forward Voltage Charts

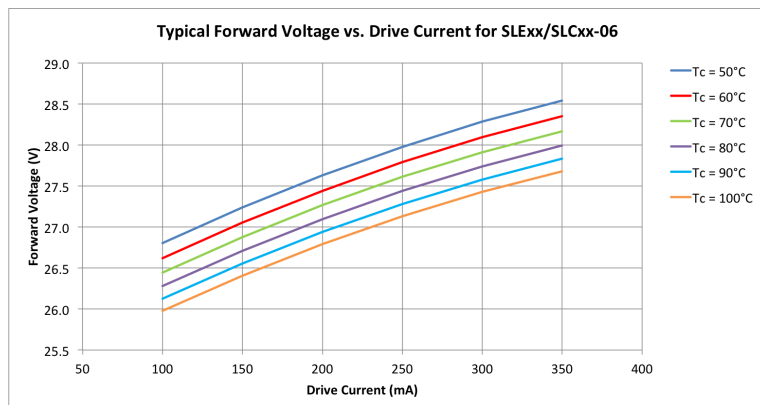
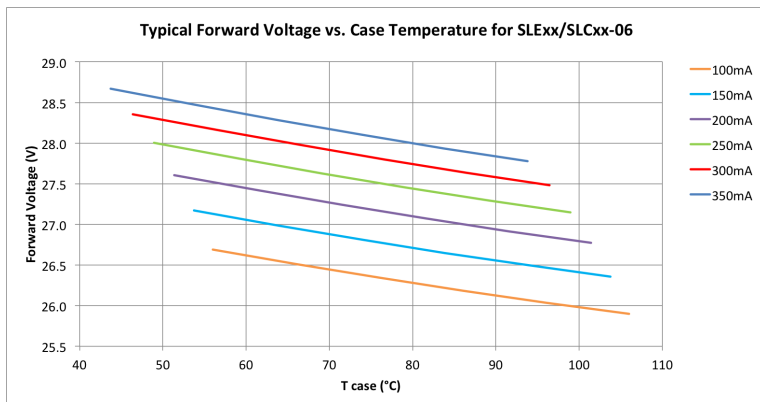

Notes:

- These charts can be applied to SLExx/SLCxx-08 by multiplying current by 2; and to SLE30/SLC30-04 by dividing current by 2.

Reference Temperature Readout

Tc	-20 °C	-10 °C	0 °C	10 °C	20 °C	30 °C	40 °C	50 °C	60 °C	70 °C	80 °C	90 °C	100 °C	110 °C	120 °C
Resistance (kOhm)	480	271	158	95	59	38	25	16	11	7.8	5.6	4.0	2.9	2.2	1.7

Notes:

1. Tolerance: +/- 5°C
2. Temperature can be assessed with an NTC next to the LED on the mounting board inside the Light Engine. See figure 1.1 for example.

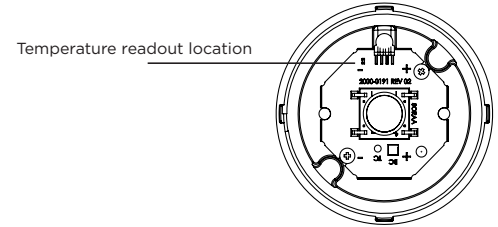

Figure 1.1

Individual Color Rendering Index

	R1	R2	R3	R4	R5	R6	R7	R8	R9	R10	R11	R12	R13	R14
2,700K 95CRI	96	97	98	93	94	93	98	97	95	95	89	76	96	98
3,000K 95CRI	96	97	97	94	94	92	98	97	96	93	90	75	96	97
4,000K 95CRI	98	98	97	97	97	94	98	97	94	95	95	84	98	99
2,700K 80CRI	81	94	88	81	85	97	79	56	7	91	82	91	85	93
3,000K 80CRI	85	96	89	85	88	97	82	61	16	94	87	86	88	94

Notes:

1. At 70°C reference point temperature, 300mA for SLE16-06-xxx and SLE11-06-xxx and 600mA for SLE30-08-xxx and SLE16-08-xxx.

CQS Color Accuracy

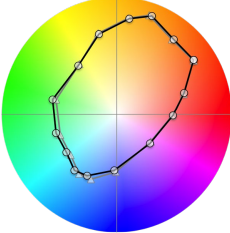
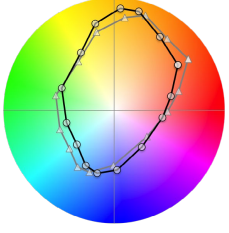
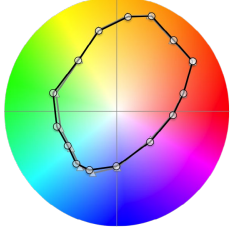
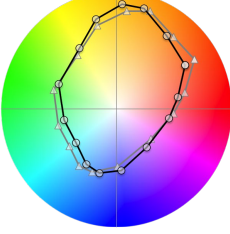
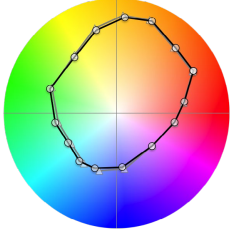
	95 CRI	80 CRI
2,700K	 <p>Qg = 102, Qf = 93</p>	 <p>Qg = 96, Qf = 79</p>
3,000K	 <p>Qg = 101, Qf = 94</p>	 <p>Qg = 96, Qf = 83</p>
4,000K	 <p>Qg = 100, Qf = 94</p>	

Notes:

1. CQS color samples, charts in La'b'
2. At 70°C reference point temperature, 300mA for SLE16-06-xxx and SLE11-06-xxx and 600mA for SLE30-08-xxx and SLE16-08-xxx.

Key:

- △— Reference
- Soraa

Spectral Power Distributions



Notes:

1. At 70°C reference point temperature, 300mA for SLE16-06-xxx and SLE11-06-xxx and 600mA for SLE30-08-xxx and SLE16-08-xxx.

Beam Diagrams

	SLx30	SLx16	SLx11
Narrow Spot 4 Degree			
Narrow Spot 9 & 10 Degree	9 Degree 	10 Degree 	
Spot 15 Degree			
Narrow Flood 25 Degree			
Flood 36 Degree			

Notes:

1. Beam plots for 3,000K 95CRI
2. At 70°C reference point temperature, 300mA for SLE16-06-xxx and SLE11-06-xxx and 600mA for SLE30-08-xxx and SLE16-08-xxx.

Mechanical Outline: SLE

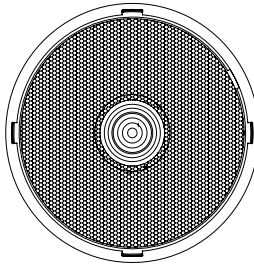
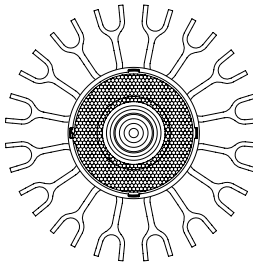
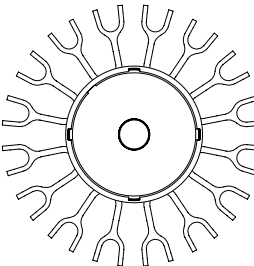
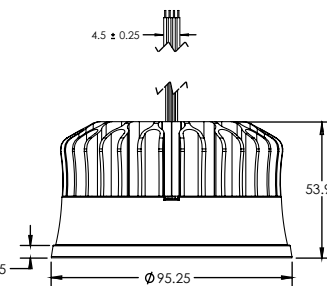
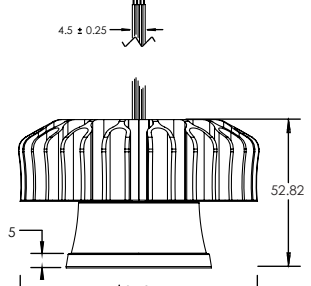
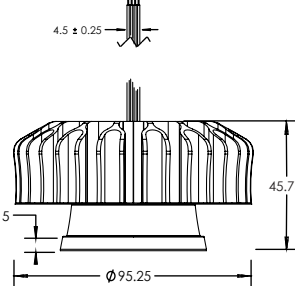
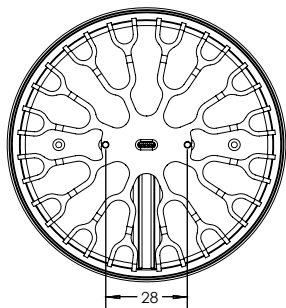
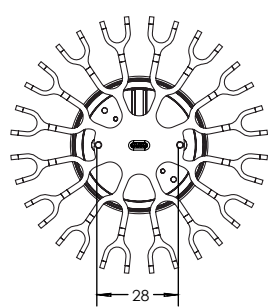
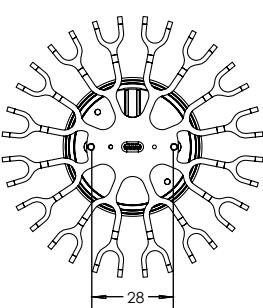
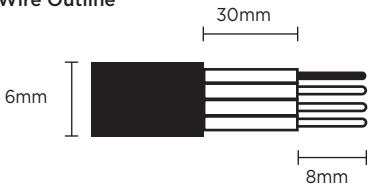
SLE30	SLE16-08-xxx-xxx-xx-03	SLE16-06-10D-xxx-xx-03
<p>Top View</p>  <p>87.0 Lens Diameter</p>	<p>Top View</p>  <p>47.0 Lens Diameter</p>	<p>Top View</p>  <p>46.7 Lens Diameter</p>
		
<p>Bottom View</p>  <p>28</p>	<p>Bottom View</p>  <p>28</p>	<p>Bottom View</p>  <p>28</p>
<p>Wire Outline</p>  <p>30mm</p> <p>6mm</p> <p>8mm</p> <p>Copper V+ (Goes to Red) V- (Goes to Black) NTC Read-out, non polarized</p> <p>* Wire Thickness: 2mm * Total Wire Length: 430mm</p>		

Notes:

1. Drawings not to scale, different scales used
2. Dimensions in mm

Mechanical Outline: SLE

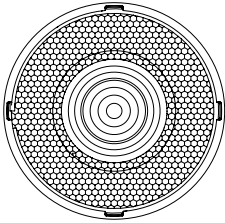
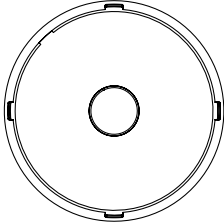
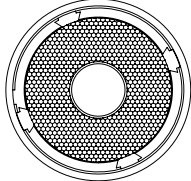
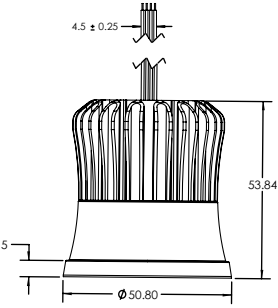
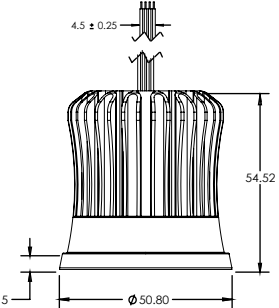
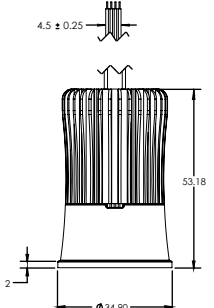
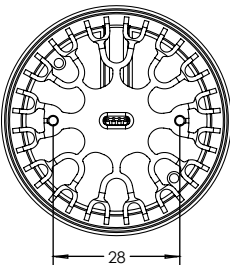
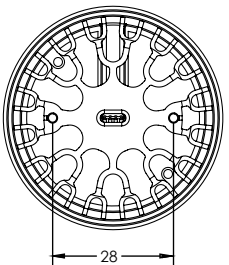
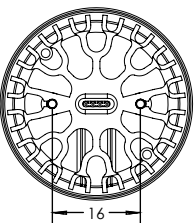
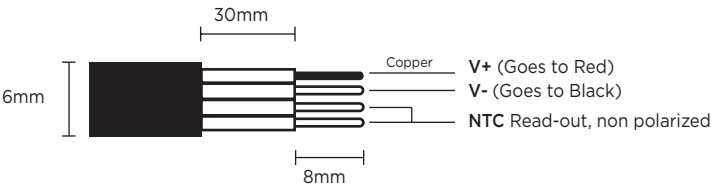
SLE16-08-xx	SLE16-06-10D-xx	SLE11
<p>Top View</p>  <p>47.0 Lens Diameter</p>	<p>Top View</p>  <p>46.7 Lens Diameter</p>	<p>Top View</p>  <p>27.6 Lens Diameter</p>
		
<p>Bottom View</p>  <p>28</p>	<p>Bottom View</p>  <p>28</p>	<p>Bottom View</p>  <p>16</p>
<p>Wire Outline</p>  <p>30mm</p> <p>6mm</p> <p>8mm</p> <p>Copper</p> <p>V+ (Goes to Red)</p> <p>V- (Goes to Black)</p> <p>NTC Read-out, non polarized</p> <p>* Wire Tickness: 2mm</p> <p>* Total Wire Length: 430mm</p>		

Notes:

1. Drawings not to scale, different scales used
2. Dimensions in mm

Mechanical Outline: SLC

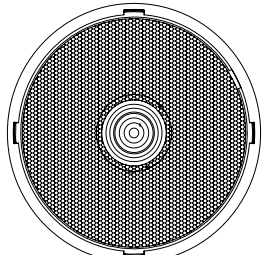
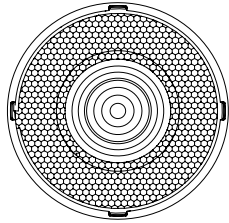
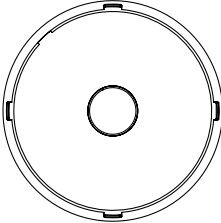
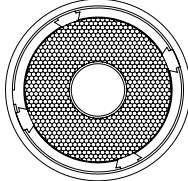
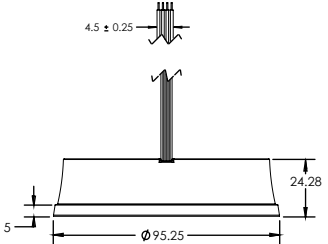
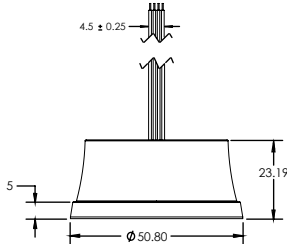
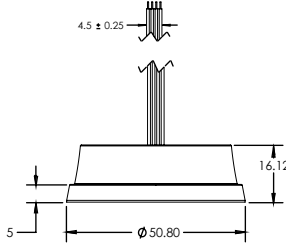
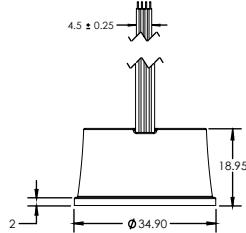
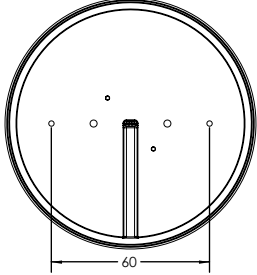
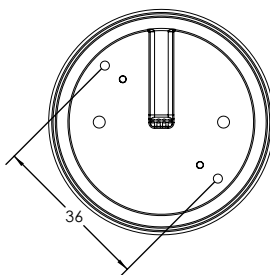
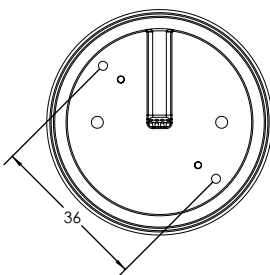
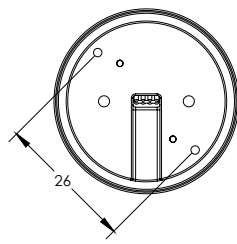
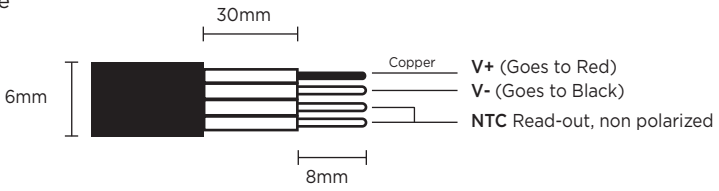
SLC30	SLC16-08-xx	SLC16-06-10D-xx SLC16-08-15D-xx	SLC11
<p>Top View</p>  <p>87.0 Lens Diameter</p>	<p>Top View</p>  <p>47.0 Lens Diameter</p>	<p>Top View</p>  <p>46.7 Lens Diameter</p>	<p>Top View</p>  <p>27.6 Lens Diameter</p>
			
<p>Bottom View</p> 	<p>Bottom View</p> 	<p>Bottom View</p> 	<p>Bottom View</p> 
<p>Wire Outline</p>  <p>6mm</p> <p>30mm</p> <p>8mm</p> <p>Copper</p> <p>V+ (Goes to Red)</p> <p>V- (Goes to Black)</p> <p>NTC Read-out, non polarized</p> <p>* Wire Thickness: 2mm</p> <p>* Total Wire Length: 430mm</p>			

Notes:

1. Drawings not to scale, different scales used
2. Dimensions in mm

Soraa Inc. — Americas HQ
6500 Kaiser Drive, Suite 110,
Fremont, CA 94555
United States
Tel: 855 GO-SORAA / 855 467-6722

Soraa Inc. — International HQ
Unit 36, Ambition Broxbourne Business Centre, Pindar Road
Hoddesdon, EN11 0FJ, United Kingdom
United Kingdom
Tel: +44 (0)1992 535053

www.soraa.com

Information and specifications subject to change. Light Engine HS Rev 2 01.25.18

SORAA*