



## C2301/C2302 Installation Instructions 2001-2010 Chevy HD 3" Lift Kit

### Read and understand all instructions and warnings prior to installation of product and operation of vehicle.

Zone Offroad Products recommends this system be installed by a professional technician. In addition to these instructions, professional knowledge of disassembly/ reassembly procedures and post installation checks must be known. Minimum tool requirements include the following: Assorted metric and standard wrenches, hammer, hydraulic floor jack and a set of jack stands. See the "Special Tools Required" section for additional tools needed to complete this installation properly and safely.

#### » PRODUCT SAFETY WARNING

Certain Zone Suspension Products are intended to improve off-road performance. Modifying your vehicle for off-road use may result in the vehicle handling differently than a factory equipped vehicle. Extreme care must be used to prevent loss of control or vehicle rollover. Failure to drive your modified vehicle safely may result in serious injury or death. Zone Offroad Products does not recommend the combined use of suspension lifts, body lifts, or other lifting devices.

You should never operate your modified vehicle under the influence of alcohol or drugs. Always drive your modified vehicle at reduced speeds to ensure your ability to control your vehicle under all driving conditions. Always wear your seat belt.

#### » TECHNICAL SUPPORT

[www.zoneoffroad.com](http://www.zoneoffroad.com) may have additional information about this product including the latest instructions, videos, photos, etc.

Send an e-mail to [tech-zone@ridefox.com](mailto:tech-zone@ridefox.com) detailing your issue for a quick response.

888.998.ZONE Call to speak directly with Zone tech support.

#### » PRE-INSTALLATION NOTES

1. Special literature required: OE Service Manual for model/year of vehicle. Refer to manual for proper disassembly/reassembly procedures of OE and related components.
2. Adhere to recommendations when replacement fasteners, retainers and keepers are called out in the OE manual.
3. Larger rim and tire combinations may increase leverage on suspension, steering, and related components. When selecting combinations larger than OE, consider the additional stress you could be inducing on the OE and related components.
4. Post suspension system vehicles may experience drive line vibrations. Angles may require tuning, slider on shaft may require replacement, shafts may need to be lengthened or trued, and U-joints may need to be replaced.
5. Secure and properly block vehicle prior to installation of Zone Offroad Products. Always wear safety glasses when using power tools.
6. If installation is to be performed without a hoist, Zone Offroad Products recommends rear alterations first.
7. Due to payload options and initial ride height variances, the amount of lift is a base figure. Final ride height dimensions may vary in accordance to original vehicle attitude. Always measure the attitude prior to beginning installation.

#### Difficulty Level

easy 1 2 **3** 4 5 difficult

Estimated installation: hours

#### Special Tools Required

Torsion Bar Unloading Tool

Cutoff tool (sawzall / cutoff wheel)

#### Tire/Wheel Fitment

33x12.50x17" w/ 5" Backspacing

**\*Important\* Verify you have all of the kit components before beginning installation.**

**C2301 Kit Contents**

Qty	Part
1	2" Diff drop - DRV Front (Left)
1	2" Diff drop - DRV Front (Right)
1	2" Diff drop - DRV Rear
2	2" Diff drop - 14mm threaded extension
1	2" Diff drop tube - Pass side
1	2" Diff drop kit - diff skid plate
1	Rivet Nut 1/2"-13 (short)
1	Rivet nut installation bolt pack
1	.75 x 0.095 x 2.400 sleeve

**791 Bolt Pack**

2	14mm-2.00 x 120mm bolt
2	14mm-2.00 Prevailing torque nut
2	14mm-2.00 x 30mm bolt
4	9/16" USS Washer
2	9/16" x 1.25" x 0.125 washer
3	1/2"-13 x 1-1/4" bolt

**791 Bolt Pack (Cont.)**

4	1/2" Thru Hardened Washer
1	1/2"-13 prevailing torque nut
2	3/8"-16 x 1-1/4" bolt
2	3/8" USS Washer
2	3/8"-16 serrated edge flanged nut
2	7/16"-14 x 1-1/4" bolt - grade 5
4	7/16" SAE Washer
2	7/16"-14 prevailing torque nut
1	5/8"-11 x 6" flat head allen bolt
1	5/8" SAE Washer
1	5/8"-11 Nylock nut

**ZonC2300 (also included in the kit)**

Part#	QTY	Description
	2	Upper Control Arm Assembly
	1	Bolt Pack
	2	wire clamps
	4	1/4"-20 x 3/4" self threading bolts

**Step 2 Note:**

Ride height is measured from the center of the wheel to the lip of the fender for a consistent measurement method for before / after lift. This way the wheel / tire size does not affect ride height measurements and gives a true lift amount.

**» INSTALLATION INSTRUCTIONS**

1. Park vehicle on clean flat and level surface. Block rear wheels for safety.
2. Measure ride height and record:
3. Measure expose bolt on torsion bar adjusters and record:  
 DRV: \_\_\_\_\_ PASS: \_\_\_\_\_
4. Raise front of vehicle and support frame rails with jackstands.
5. Remove wheels



Figure 1

6. Remove the torsion bar adjusting bolts, do not mix the right and left bolt. Fig 1



Figure 2

7. Use the torsion bar removal tool to remove the threaded adjuster assembly. Release the pressure from torsion bar with the unloading tool. Caution: There is an extreme amount of energy stored in the torsion bars. Use extreme care with the proper tools to avoid serious injury or death. Fig 2
8. Slide the torsion bars forward to allow the keys to be removed. It may be necessary to use an air hammer to get the bars to break free.
9. Loosen all lower control arm hardware, do not remove the nuts, it is only necessary to have them broken free to allow for full movement.

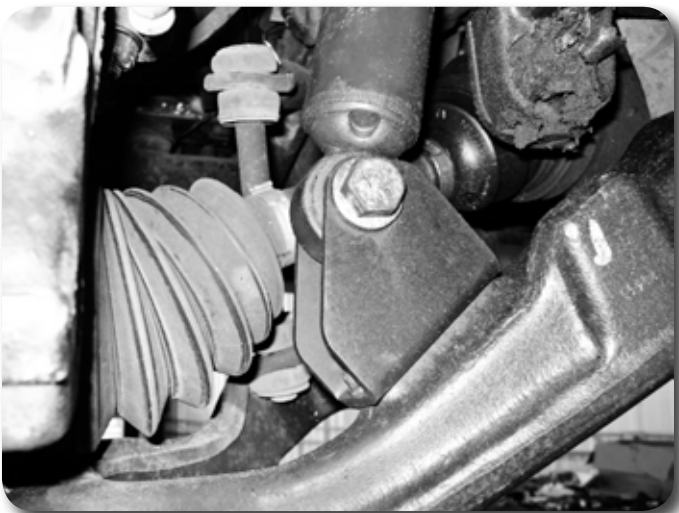

Figure 3

### Figure 3 Note:

**CAUTION:** Remove the lower shock bracket from the control arm. The bolts are often frozen in the arm. It is best to use a small amount of heat and penetrating oil to get the bolts to break free. Do not use an impact! Take your time and use caution.

10. Disconnect the front shocks and remove from vehicle, retain the lower mounting bolt. Remove the lower shock bracket, use EXTRA caution not to break the bolts.  
**Fig 3**
11. Disconnect the brake line and ABS wire from the upper control arm.
12. Working on one side of the vehicle at a time. Support the lower control arm. Disconnect the CV from the front differential, retain all hardware. Remove the upper control arm from the vehicle. This will allow the CV to separate and be removed easily. Do not let the brake lines hold lower control arm assembly up.



*Figure 4*

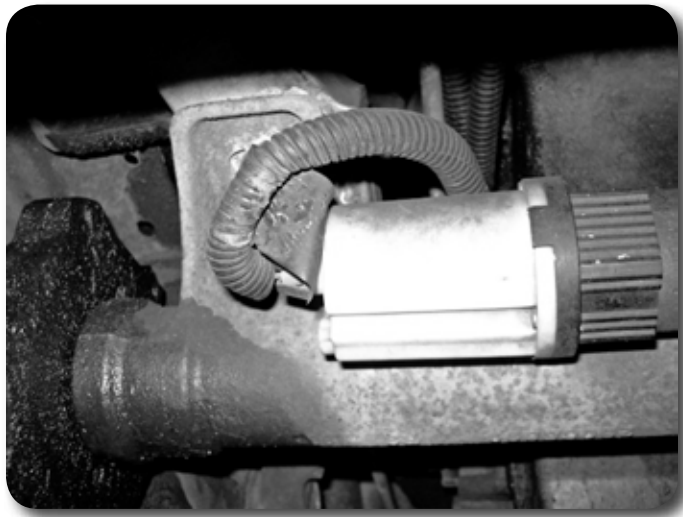
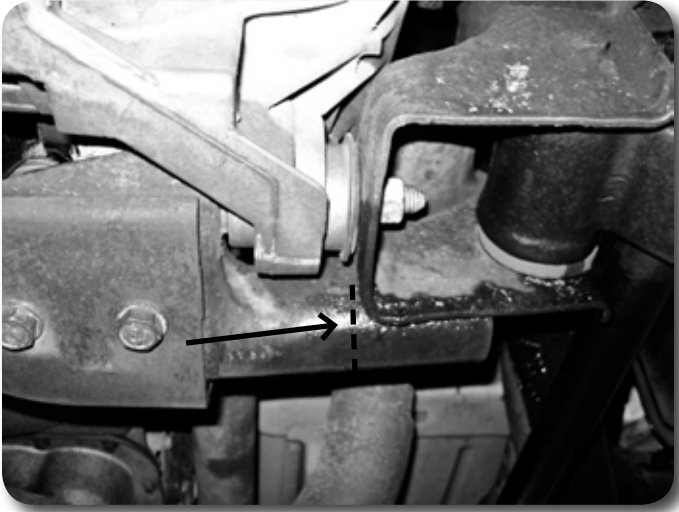

*Figure 5*

13. Disconnect the breather tube and front differential actuator wiring harness from the front differential. Remove the wires from the retaining clips that are attached to the diff. **Fig 4, 5**
14. Remove the rear cross member (between lower control arm rear mounts) from the vehicle, retain the passenger's side hardware.
15. Remove the 4 bolts that hold the driveshaft u-joint straps in place. Retain all hardware and straps for reinstallation later.



*Figure 6*



*Figure 7*

**Figure 7 Note:**

Cut at line to allow for easy differential removal. Turn the steering wheel to one side, to aid in front mount clearance for differential removal.

16. Remove the driver's side rear differential bolt. Trim this area to allow for differential removal. Fig 7
17. Support the differential with a jack and remove the driver's side front mounting bolt and the 2 nuts on the passenger's side.
18. Lower the differential and remove from vehicle.

**Figure 8 Note:**

Trim off the rear section see figure 9a for the allowable amount of material after trimming. The square tube needs to be cut off as shown in '2nd cut.'

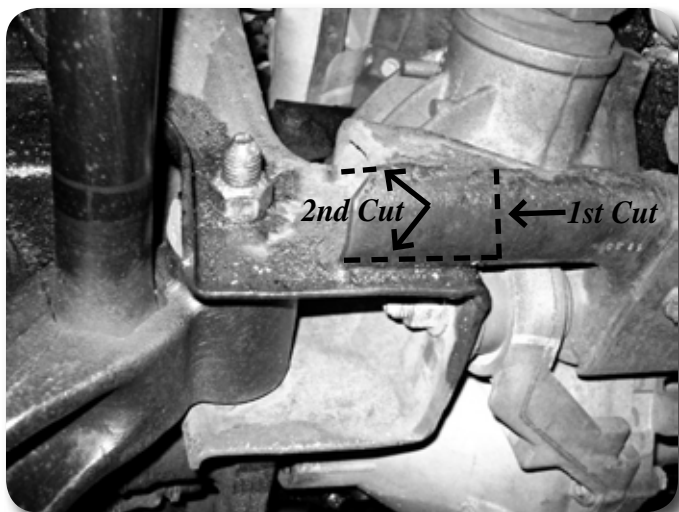

Figure 8

19. Trim the square tube portion off flush with the driver's side lower control arm pocket. There is clearance built into the replacement bracket for this piece of material to be left as shown. Fig 8

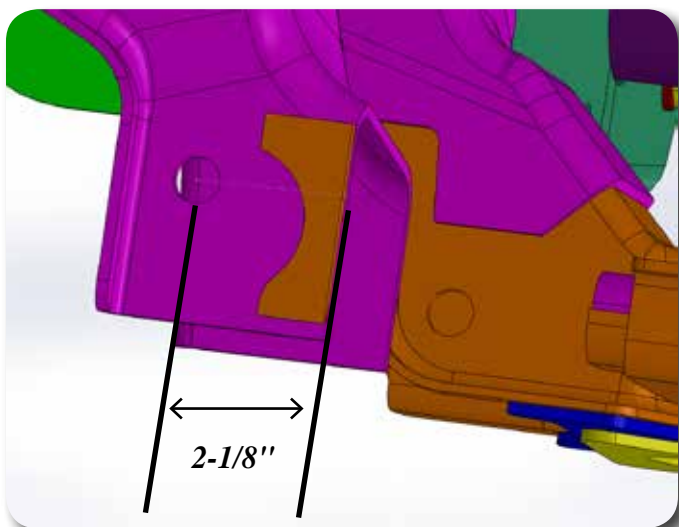

Figure 9a

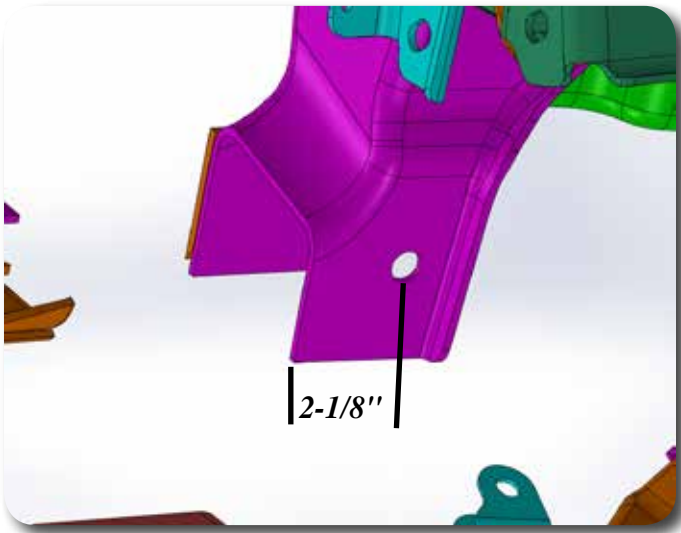

Figure 9b

20. Measure over 2-1/8" from the center of the lower control arm and remove this section of material. A sawzall is highly recommended, if a plasma cutter is used, it is recommended to remove the lower control arm from the pocket. Deburr and coat any exposed metal with paint. Fig 9a, 9b

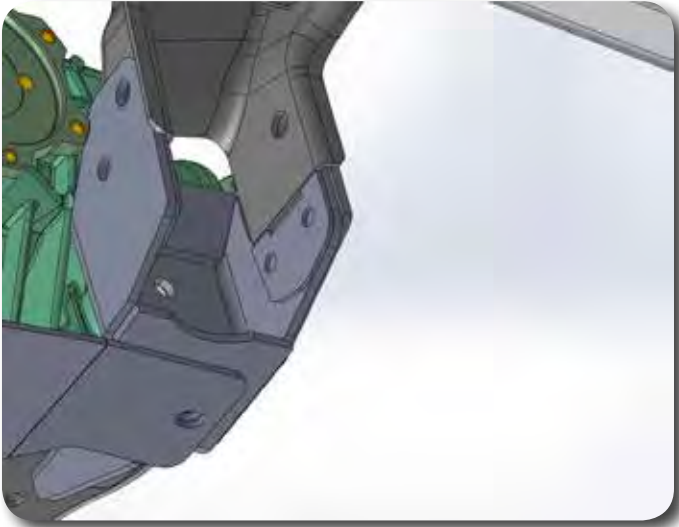
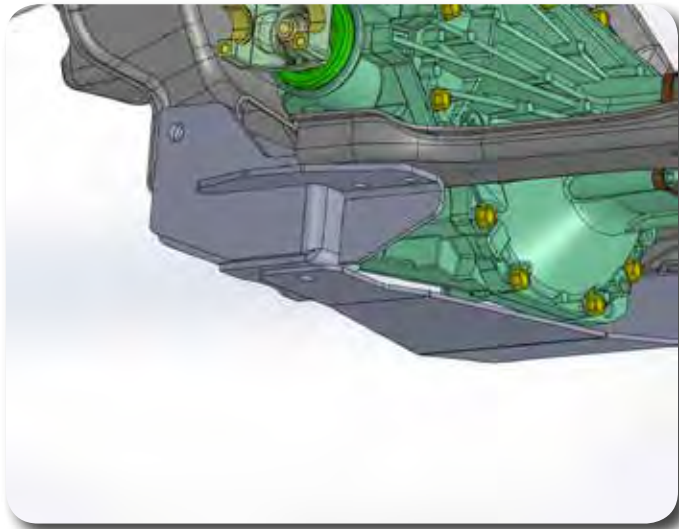

Figure 10

21. Remove the Driver's side rear lower control arm bolt. Place bracket up into position. Mark center of hole and drill to 1/2", this step can be skipped if the bracket is welded in place (see next step) Fig 10



*Figure 11a*



*Figure 11b*

**Figure 11b Note:**

Use 5/8" flat head allen bolt to attach the bracket to the frame.

22. It is highly recommended, but not necessary to run a 1" long weld bead on both the front and back side to attach the bracket to the factory control arm pocket. When welding the bracket into place, remove the lower control arm from the pocket. Prep the bracket by removing paint and weld into place. Fig 11a Reinstall bracket with flat head allen bolt through the lower control arm and 1/2" hardware. Snug, but do not tighten at this time. Fig 11b



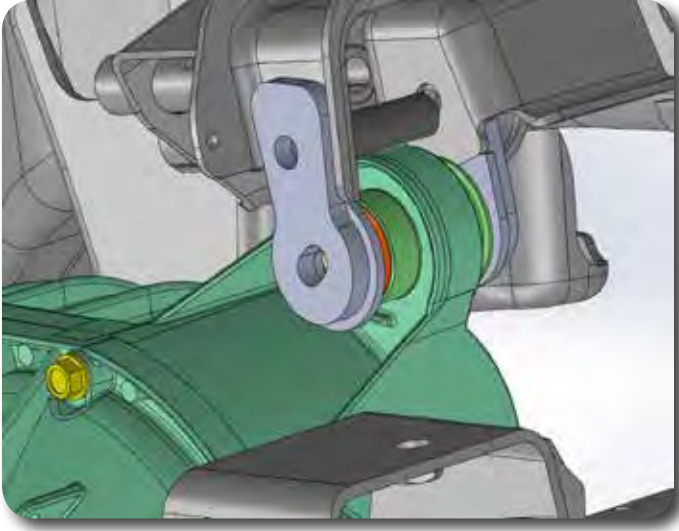

*Figure 12a*

**Figure 12a Note:**

Driver front differential mount requires a spacer sleeve to be installed. See Figure 12a



*Figure 12b*

23. Install the driver's side front upper mount brackets. There will be a crush sleeve that gets installed in place of the original pocket. Use 14mm hardware and leave loose at this time. Fig 12a, 12b

24. Passenger's side differential mount studs may need trimmed, max stud length is 1-1/8". Measure and trim to 1-1/8" or less most model trucks will not need the studs trimmed..

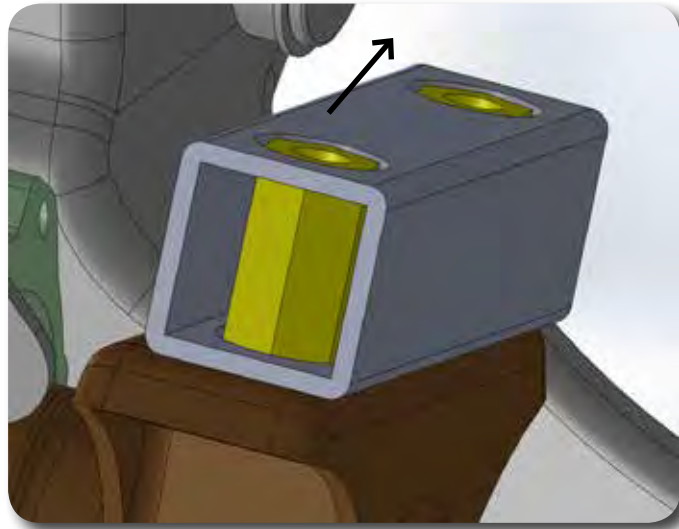

Figure 13a



Figure 13b

25. Install hex standoffs onto the factory studs. Tighten to 95 ft-lbs. Fig 13a
26. Raise differential into vehicle. Attach the rear mount on the driver's side first with factory hardware. Do not tighten at this time. Fig 13b
27. Rotate the differential down to install the Passenger's side spacer tube. Attach with 14mm bolt with large diameter extra thick washers. Do not tighten at this time.
28. Attach driver's side front mount with new 14mm hardware.
29. Tighten all 14mm differential hardware (4 places) to 95 ft-lbs.



*Figure 14*

30. Reinstall the rear factory crossmember. It will attach to the top side of the new relocation bracket on the driver's side. Use new 7/16" hardware and factory hardware on passenger's side. Fig 14



*Figure 15*

31. Reattach CV shafts to the differential with factory hardware. Tighten to 45 ft-lbs. Fig 15
32. Reattach differential breather and wire harness to front diff.

33. Reattach the driveshaft with factory hardware and straps. Tighten to 19 ft-lbs.

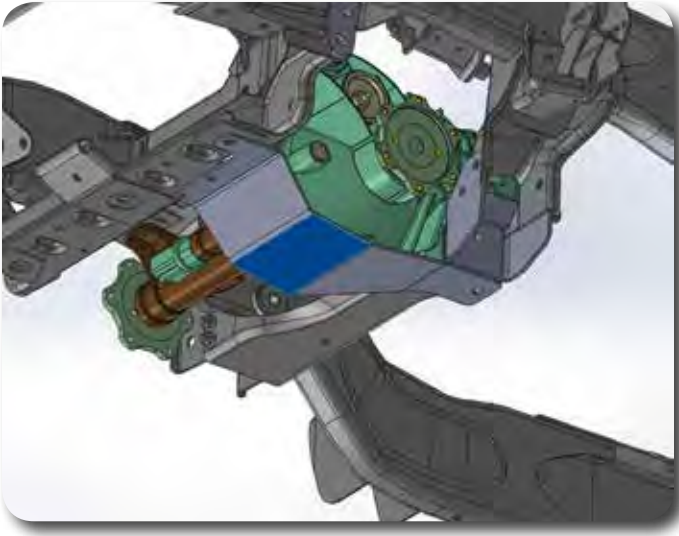

*Figure 16a*



*Figure 16b*

34. Clearance the factory hole to 11/16". Install rivet nut (see end of instruction sheet for specific details on how to install a rivet nut). Fig 16
35. Loosely fit the new skid plate. Mark the center of the two additional slots, remove skid plate, and drill to 7/16".



*Figure 17*

36. Reinstall skid plate with new 1/2" and 3/8" hardware. The 1/2" hardware will thread into a welded nut in the rear bracket and into the rivet nut in the front bracket. Use serrated edge flange nuts on the top side with 3/8" hardware. Fig 17
37. Install new shock bracket with factory bolts so that the new hole is offset closer to the frame rails. The shock bracket is included in the front shock box. Tighten to 40 ft-lbs.



*Figure 18*

38. Clearance the upper control arm pockets with a flap disc to ensure adequate clearance. The very edge needs to be chamfered to give the arms extra clearance. Fig 18
39. Install the new upper control arm assemblies. Tighten the upper ball joint to 65 ft-lbs. Install the cotter pin provided with the kit. Do not loosen the nut to install the cotter pin, it is acceptable to tighten it a slight amount more for engagement.



*Figure 19*

40. Adjust the cams so that both cams are centered. This is NOT the final alignment settings, but is a good start of where they should be. Snug the cam bolts, but do not torque at this time. Check for clearance to the factory pockets and adjust (form / grind) the pocket as necessary to gain clearance. Fig 19



*Figure 20*

41. Attach the factory brake line bracket to the upper control arm with 1/4" self threading bolts. Attach the ABS wire with retaining clip and 1/4" self threading bolt. Fig 20

42. Install / reinstall shocks, attach with factory bolt at the lower mount.
43. Install new torsion bar keys. Install the torsion bars into the keys. Using a proper tool, reinstall the bridge and torsion bar adjusting bolt.
44. Adjust the bolts to their original height. Note: The bolts may need to be adjusted after the final ride height is determined.
45. Reinstall wheels, tighten to factory specifications.
46. Lower the vehicle to the ground.
47. Tighten upper control arm hardware to 65 ft-lbs.
48. Tighten lower control arm hardware to 115 ft-lbs.
49. Roll the vehicle forward and back. Check ride height. 2001-2006 trucks should be approximately 26-1/4" and 2007 and newer should be 27-1/4". Do not adjust higher than this or vehicle handling may suffer.
50. Adjust the toe-in setting to approximately 1/8". The toe must be adjusted before driving the vehicle to an alignment shop.
51. Recheck all hardware for proper torque. An alignment is now required. Check again after 500 miles.

## Rear Installation Instructions

NOTE: Complete the following instructions one side at a time. Do not attempt to drop the entire axle at one time.

1. Raise rear of vehicle and support with jack stands under frame. Remove wheels.
2. With axle firmly supported by jack stands remove the OEM shock. Place a hydraulic jack under the rear differential.
3. Loosen the OEM u-bolts that retain the spring to the axle.
4. With the hydraulic jack supporting the axle, slowly allow the axle to drop away from the leaf spring. Replace the jack stands for additional support.
5. Place the new block between the stock block and the leaf pack. Make sure the bump stop portion of the stock block is pointed the same direction as it was originally.
6. Slowly raise the axle with the hydraulic jack in order to assemble the blocks and leaf springs. Make sure that all of the locating pins are inside their female counterparts.
7. Install u-bolts with the supplied fasteners. Be sure the u-bolts are perpendicular to the axle before tightening.
8. Tighten the u-bolts to 100-120 ft-lbs. Replace wheels. Install correct Zone shocks recommended for this amount of lift. Replace the wheel.
9. Complete the above instructions for the other side of the vehicle.

## Rivet Nut Installation Instructions

### » HOLE PREPARATION

10. Drill hole to appropriate size for rivet nut installation. 1/2" Rivnuts require an 11/16" hole and 3/8" Rivnuts require a 17/32" drill. It is critical that this hole is drilled to the correct size. Remove any burrs that could keep the rivet nut from seating flat against either side of the hole surface. **Figure 1A/B.**

### Step 3 Caution:

To avoid axle shift, only remove/replace the u-bolts from one side at a time.

### Step 4 Caution:

It may be necessary to adjust the brake line in order to gain additional length. Do not kink the brake line in any way.

### Step 6 Caution:

Do not bring this assembly under pressure until the u-bolts have been installed.

### Step 7 Caution:

Be sure to install the u-bolts under the brake line.

### Step 10 Note

If the correct drill size is not available, it is possible to drill the hole to an available smaller size and slowly grind it out to until the rivet-nut fits tight.

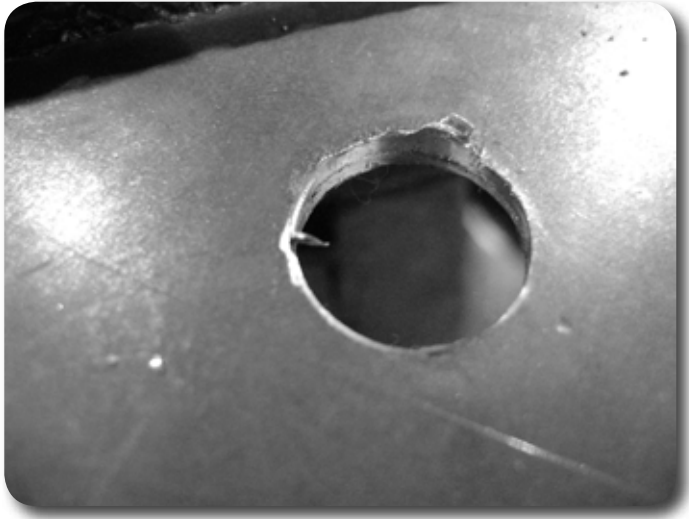

*Figure 1A*

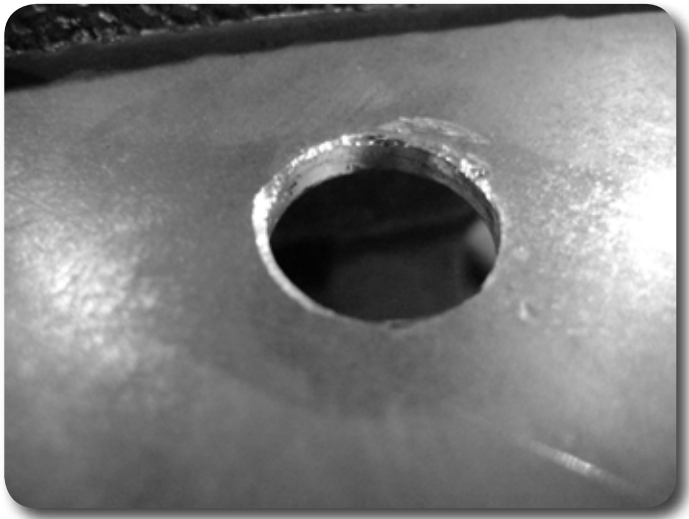

*Figure 1B*

---

### » RIVET NUT INSTALLATION TOOL ASSEMBLY

11. For a 3/8" rivet nut, place the provided 3/8" SAE flat washer on the 3/8" x 1-1/2" bolt, followed by 7/16" hex nut and then a 3/8" serrated washer. **Figure 2** Thread this tool assembly into the rivet nut.
12. For a 1/2" rivet nut, place the provided 1/2" SAE washer on a 1/2" x 2" bolt followed by a 9/16" high nut and 1/2" serrated edge lock washer. Thread this tool assembly into the rivet nut as shown. **Figure 3.**



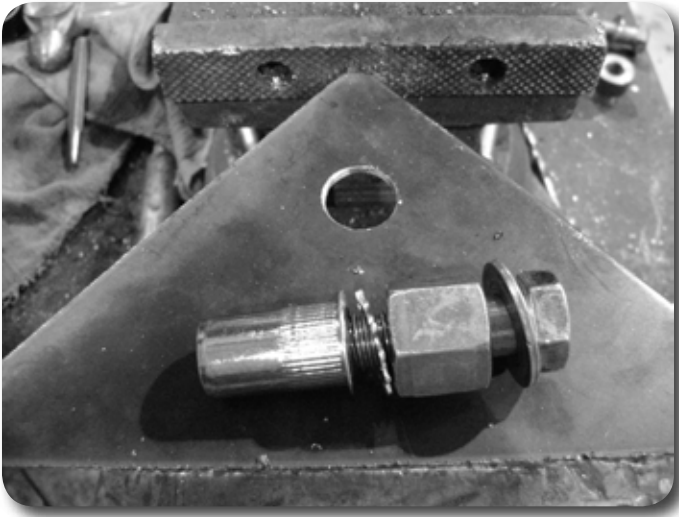

Figure 3 - 1/2" Rivet Nut Shown

## » RIVET NUT INSTALLATION

13. Verify the correct size rivet nut for the application based on the thickness of material where the rivet nut is to be installed using the following chart.

Part Number	Thread Size	Body Length (in)	Material Thickness (in)		Drill Size (in)
			Min.	Max.	
95105A159	3/8-16	.690	.027	.150	17/32
95105A168	3/8-16	.805	.150	.312	17/32
95105A169	1/2-13	1.150	.063	.200	11/16
95105A170	1/2-13	1.300	.200	.350	11/16

14. Place the installation tool with the rivet nut threaded on the end into the appropriately sized hole.
15. For a 3/8" rivet nut, hold the nut closest to the rivet nut still with an 5/8" wrench and tighten the 3/8" bolt with a 9/16 wrench to set the rivet nut. Be sure to hold the rivet nut flush to the surface and square to the hole as it is tightened. **Figure 4**
16. For a 1/2" rivet nut, hold the nut closest to the rivet nut still with an 7/8" wrench and tighten the 1/2" bolt with a 3/4" wrench to set the rivet nut. Be sure to hold the rivet nut flush to the surface and square to the hole as it is tightened. **Figure 4**

### Step 15 & 16 Note

If available, an impact gun is recommended for tightening the bolt to ensure the rivet nut remains square to the hole and to ease holding the nut from spinning.

### Step 17 & 18 Note

If using the recommended impact gun, use caution to not exceed the recommended torque specifications.



Figure 4 - 1/2" Rivet Nut shown

---

### » TORQUE SPECIFICATIONS

17. 3/8" rivet nuts will approach 40 ft. lbs for maximum grip strength. Do not exceed 45 ft-lbs when setting the rivet nut.
18. 1/2" rivet nuts will approach 90 ft lbs for maximum grip strength. Do not exceed 100 ft-lbs when setting the rivet nut.

### Step 20\*IMPORTANT\*

It is very important to hold the nut as the bolt is loosened because the grip of the star washer will try to spin the rivet nut and ruin the installation.

---

### » RIVET NUT TOOL REMOVAL

19. Once the center bolt is tightened, remain holding the nut from spinning with the wrench and loosen the center bolt to remove the installation tool.
20. Verify proper installation by checking for consistent rivet nut deformation to see the threads are square and centered to the rivet nut. Figure 5.

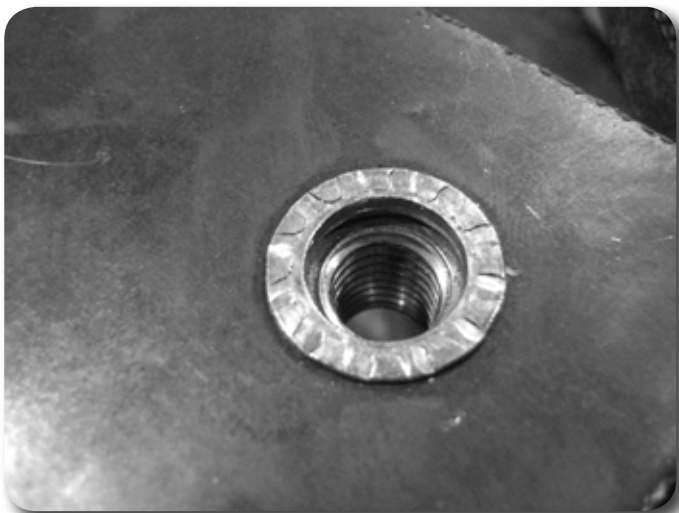

Figure 5