



#D1511, D1512, D1513, D1514 Installation Instructions 1994-1999 Dodge 1/2 Ton 4WD & 1994-2002 Dodge 3/4 Ton 4WD

Read and understand all instructions and warnings prior to installation of product and operation of vehicle.

Zone Offroad Products recommends this system be installed by a professional technician. In addition to these instructions, professional knowledge of disassembly/ reassembly procedures and post installation checks must be known. Minimum tool requirements include the following: Assorted metric and standard wrenches, hammer, hydraulic floor jack and a set of jack stands. See the "Special Tools Required" section for additional tools needed to complete this installation properly and safely.

» PRODUCT SAFETY WARNING

Certain Zone Suspension Products are intended to improve off-road performance. Modifying your vehicle for off-road use may result in the vehicle handling differently than a factory equipped vehicle. Extreme care must be used to prevent loss of control or vehicle rollover. Failure to drive your modified vehicle safely may result in serious injury or death. Zone Offroad Products does not recommend the combined use of suspension lifts, body lifts, or other lifting devices.

You should never operate your modified vehicle under the influence of alcohol or drugs. Always drive your modified vehicle at reduced speeds to ensure your ability to control your vehicle under all driving conditions. Always wear your seat belt.

» TECHNICAL SUPPORT

Live Chat provides instant communication with Zone tech support. Anyone can access live chat through a link on www.zoneoffroad.com.

www.zoneoffroad.com may have additional information about this product including the latest instructions, videos, photos, etc.

Send an e-mail to tech@zoneoffroad.com detailing your issue for a quick response.

888.998.ZONE Call to speak directly with Zone tech support.

» PRE-INSTALLATION NOTES

1. Special literature required: OE Service Manual for model/year of vehicle. Refer to manual for proper disassembly/reassembly procedures of OE and related components.
2. Adhere to recommendations when replacement fasteners, retainers and keepers are called out in the OE manual.
3. Larger rim and tire combinations may increase leverage on suspension, steering, and related components. When selecting combinations larger than OE, consider the additional stress you could be inducing on the OE and related components.
4. Post suspension system vehicles may experience drive line vibrations. Angles may require tuning, slider on shaft may require replacement, shafts may need to be lengthened or trued, and U-joints may need to be replaced.
5. Secure and properly block vehicle prior to installation of Zone Offroad Products. Always wear safety glasses when using power tools.
6. If installation is to be performed without a hoist, Zone Offroad Products recommends rear alterations first.
7. Due to payload options and initial ride height variances, the amount of lift is a base figure. Final ride height dimensions may vary in accordance to original vehicle attitude. Always measure the attitude prior to beginning installation.

Difficulty Level

easy 1 2 **3** 4 5 difficult

Estimated installation: hours

Special Tools Required

Pitman Arm Puller

Tire/Wheel Fitment

35 x 12.50 w/ 4-1/2" Backspace wheels

***Important* Verify you have all of the kit components before beginning installation.**

Kit Contents

Qty	Part
2	Coil Spring
2	Bump Stop
1	Pitman Arm (94-99)
1	Bolt Pack (Brake line relocation)
8	1/4" USS washer clear zinc
4	1/4"-20 x 1" bolt grade 5 clear zinc
4	1/4"-20 prevailing torque nut clear zinc
1	Track Bar Bracket
1	Track Bar Bracket Washer
1	Bolt Pack - Track Bar Bracket
1	18mm-2.50mm x 70mm bolt grade 10.9
1	18mm thru-hardened washer
1	18mm-2.50mm prevailing torque nut
1	1/8" x 2" cotter pin clear zinc
1	1/2"-13 x 2 1/2" bolt grade 8
1	1/2" USS washer clear zinc
1	1/2" SAE washer clear zinc
1	1/2"-13 prevailing torque nut clear zinc
2	Front Brake Line Bracket
1	Rear Brake Line U-Brkt
8	Bushing - 3/4" ID
8	Bushing - 7/8" ID
6	90 Deg. Grease Fitting
2	Straight Grease Fitting
2	Lower control arm (19.5")
2	Upper control arm (18.25")
4	3/4" x 0.134 x 2.250 Sleeve (94-99)
4	7/8" x 0.120" x 2.510" Sleeve
1	5/16" x 1" Self threading bolt

»» 94-01 DODGE 1500 ONLY:

Qty	Part
2	Sway bar U -brackets
2	Sway bar links (7.5")
2	Hourglass bushings EB1 - 5/8" ID
2	Hourglass bushings EB1 - 3/4" ID
2	Sleeve - lower (3/4" x 12mm ID x 1.98")
2	Sleeve - upper (5/8" x 10mm ID x 1.38")
1	Bolt pack - sway bar links
2	12mm-1.75 x 75mm bolt -clear zinc
2	12mm-1.75 Prevailing torque nut
2	12mm flat washer - clear zinc
2	7/16" USS washer - clear zinc
2	5/8"-11 nylock nut - clear zinc
2	5/8" SAE Washer - clear zinc
2	3/8"-16 x 2-1/4" bolt - yellow zinc
4	3/8" SAE Washer - yellow zinc
2	3/8"-16 Prevailing torque nuts

»» REAR KIT

Qty	Part
2	Rear Block
4	9/16" x 2-9/16" x 1350 SQR u - bolts
2	Add-A-Leaf
2	3/8" Center pin - 4.5" long
8	9/16" High nut - black
8	9/16" Washer - black



Installation Instructions

1. Park vehicle on clean, flat, and level surface. Block the rear wheels for safety.
2. Disconnect the trackbar from the frame. Retain nut, discard cotter pin. Figure 1



Figure 1

3. Raise the front of the vehicle with a hydraulic jack. Secure the frame rails with jackstands. Do NOT work under an unsupported vehicle.
4. Raise the front axle with a hydraulic jack, remove the front wheels.
5. Raise the hood, remove the upper shock nut, bushings, and cup washers. Remove the three nuts that attach the shock tower to the upper coil bucket. Retain nuts. Figure 2a, 2b



Figure 2a

Important—measure before starting!

Measure from the center of the wheel up to the bottom edge of the wheel opening

LF _____ RF _____

LR _____ RR _____

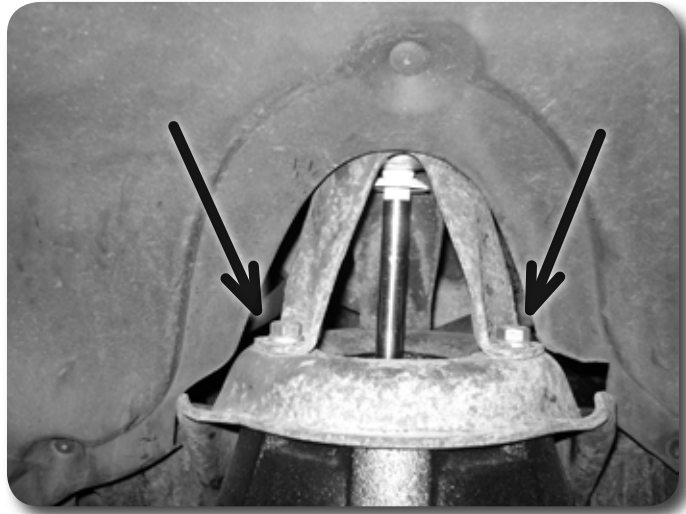

Figure 2b

6. Disconnect the lower shock hardware, retain bolts. Remove the front shocks, they will not be reused.
7. Disconnect the brakeline brackets where they attach to the axle between the upper and lower control arms. Retain bolt. Figure 3a, 3b



Figure 3a



Figure 3b

8. Disconnect the steering stabilizer hardware, and remove from vehicle. Disconnect the drag link from the pitman arm. Retain factory nut, discard cotter pin. Figure 4)



Figure 4

9. 1500 models: Remove the sway bar links from the vehicle, they will not be reused. 2500 trucks: Disconnect the sway bar links from the axle, leave them attached to the sway bar. Retain bushings for reinstallation at a later. Figure 5

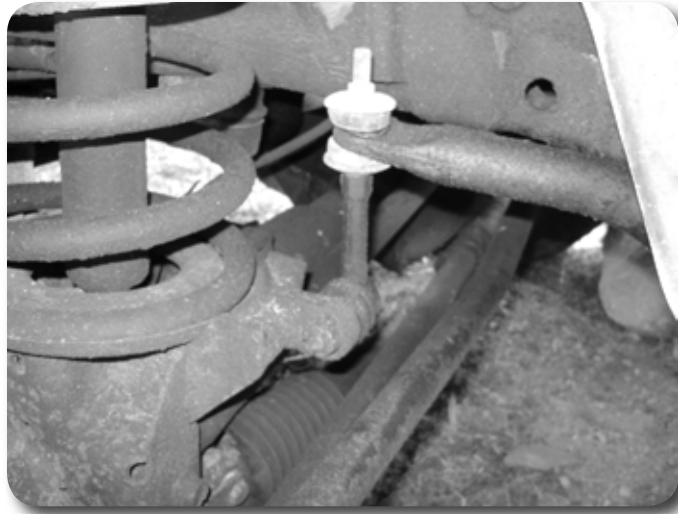

Figure 5

10. Lower the axle until the coils become unseated. Remove them from the vehicle.
11. Remove the factory bumpstops. Hitting from the side to get them to pop out.

Figure 6



Figure 6

12. Grease bushings and sleeves and install them into the control arms. The short sleeves (3/4" OD) and bushings go into the upper arm, lower arm receives the longer bushings (7/8" OD) and sleeves.
13. Thread grease fittings into the threaded holes of the arms. Adjust the fittings so they point as indicated in the following figure. Lower arm gets a straight grease fitting at the axle end. All of the rest of the fittings are 90 degree zerks. Rotate them so they will be accessible once installed on the vehicle. **Figure 7**

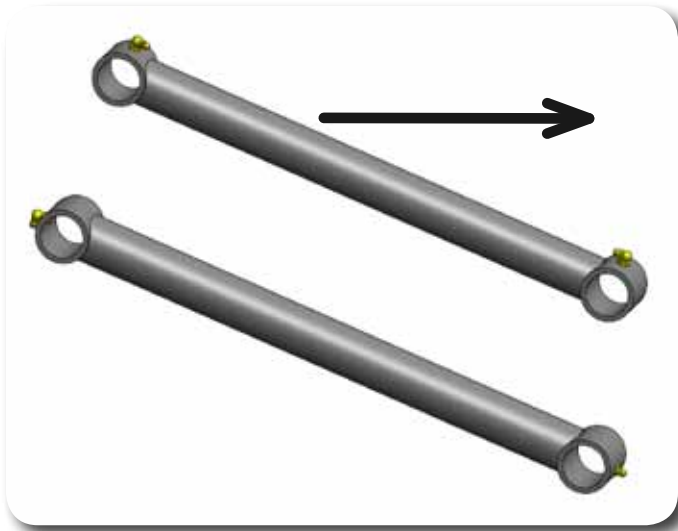

Figure 7

14. Work on one side of the vehicle at a time. Remove the control arms.
15. Lower the axle enough to allow the new coils to be installed. Compress the coil slightly to allow for installation of the control arms.
16. Install the new control arms with the grease fittings in the correct orientation with factory hardware. Do not tighten at this time.
17. Insert the shocks inside the coil. Reinstall the upper shock mount brackets with factory hardware. Attach the new shocks with new bushings, cup washers, and nut on top. Reattach to lower mount with factory bolt. Tighten lower hardware to 55 ft-lbs.
18. Repeat installation procedure on opposite side of vehicle.
19. Remove the factory brakeline retaining clip on the backside of the trackbar crossmember. Place the trackbar bracket up to the original mount and secure with 18mm bolt. Mark center of hole on support crossmember and drill $\frac{1}{2}$ " through the entire crossmember.
20. Attach trackbar relocation bracket with 18mm hardware, $\frac{1}{2}$ " hardware with special washer as shown. Tighten 18mm bolt to 150 ft-lbs and $\frac{1}{2}$ " hardware to 65 ft-lbs. Wait until the vehicle is on the ground to hook up the trackbar to the trackbar relocation bracket. Figure 8a, 8b

Step 14 Note

These trucks are notorious for having frozen lower cam bolts. A large cutoff wheel (6") is the easiest way to remove the bolts. Remove the nut and wedge a punch to spread the pocket. Cut the excess bolt thread that is sticking out. Cut the head off the bolt and remove the cam. Repeat the process, by spreading the pocket with a punch and cutting the rest of the bolt to allow the control arm to slide out. Use lots of caution, proper safety gear, and take your time to avoid damaging the pocket. Replacement cam bolts will need to be ordered from a dealership.

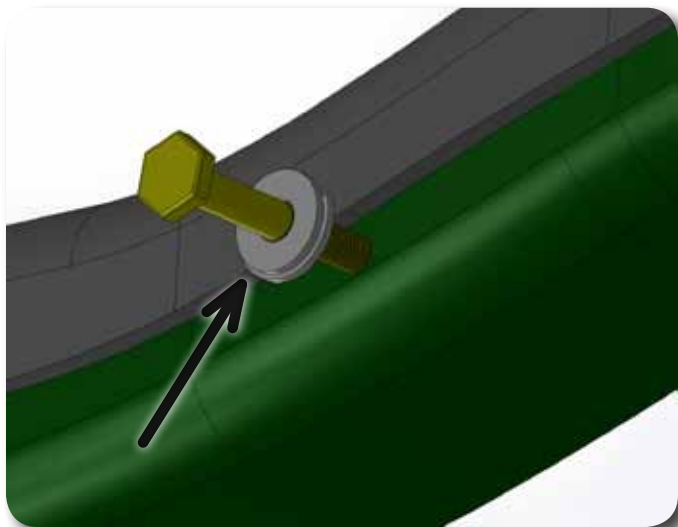

Figure 8a

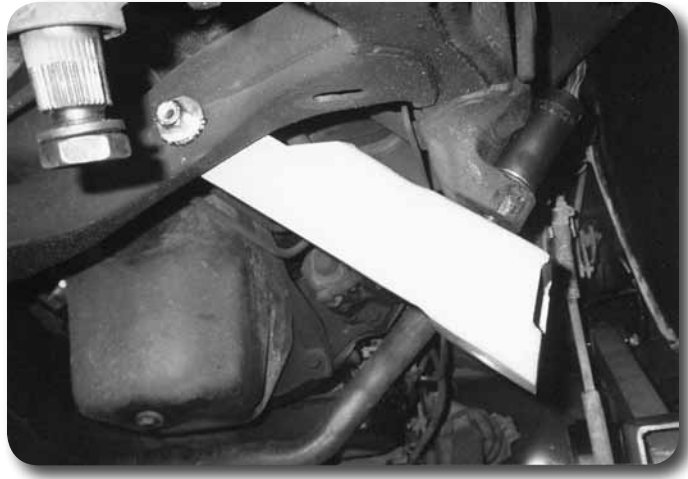

Figure 8b

21. Slide the brakeline bracket further down the frame crossmember. Mark the center of the retaining bracket and drill to 9/32". Reattach the brakeline to the frame crossmember with new self threading bolt 5/16" bolt.
22. Mark the orientation of the factory pitman arm. Remove pitman arm and install new dropped pitman arm. Tighten pitman arm with factory nut and lock washer to 185 ft-lbs.
23. Loosen steering clamps and rotate drag link 180 degrees. Reattach drag link to pitman arm with factory castellated nut, tighten to 65 ft-lbs. Use new cotter pin to secure nut. Do not back nut off to get the slots to align.
24. Install new steering stabilizer, not included with this kit. If a Zone stabilizer is not installed, the replacement must have either a bracket or reversed tapered stud to fit the flipped drag link taper.
25. Install brakeline relocation bracket to the axle between the upper and lower control arm with factory hardware. Attach brakeline to relocation bracket. Figure 9

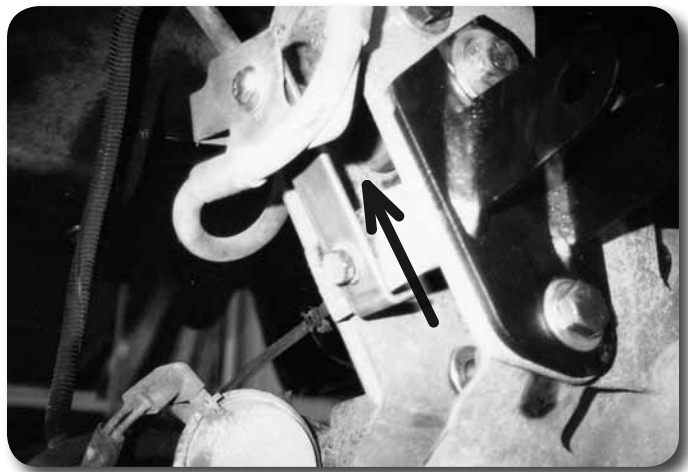

Figure 9

26. 1500 models: Install new sway bar links with clevis bracket at the sway bar. Small diameter bushing and sleeve go into the bolt on clevis. Figure 10



Figure 10

27. 2500 models: Remove the sway bar from the vehicle and flip. Reattach the sway bar to the top side of the axle mounts. Figure 11



Figure 11

28. Check the front driveshaft dual cardan (joint at the t-case) for clearance. If there is not enough clearance to allow the driveshaft to rotate, take a die grinder and clearance the webbing for adequate clearance. Figure 12

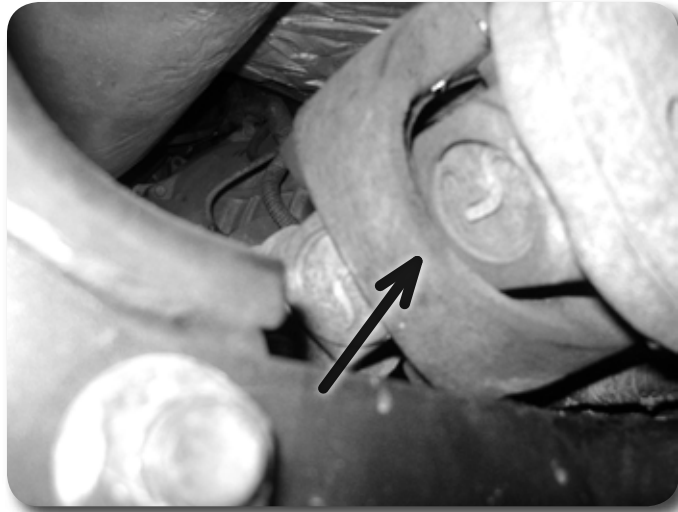

Figure 12

29. Reinstall wheels, torque to factory specification.
30. Grease new bumpstops and place a couple short pieces of 2x4's between the bump stops and axle. Lower the front of the vehicle to the ground and get the bumpstops to pop into the factory cups. Once installed, lift vehicle and remove 2x4's, set vehicle back on ground.
31. Have an assistant turn the steering wheel to align the trackbar into the trackbar bracket. Attach with factory nut, tighten to 75 ft-lbs., install new cotter pin.
32. Tighten control arm hardware as follows: Upper - 65 ft-lbs, Lower - 110 ft-lbs.

»» REAR KIT INSTALLATION

33. Block front wheels, raise rear of vehicle and support frame rails with jackstands. Remove rear wheels.
34. Disconnect the rear brakeline from the frame. Figure 13

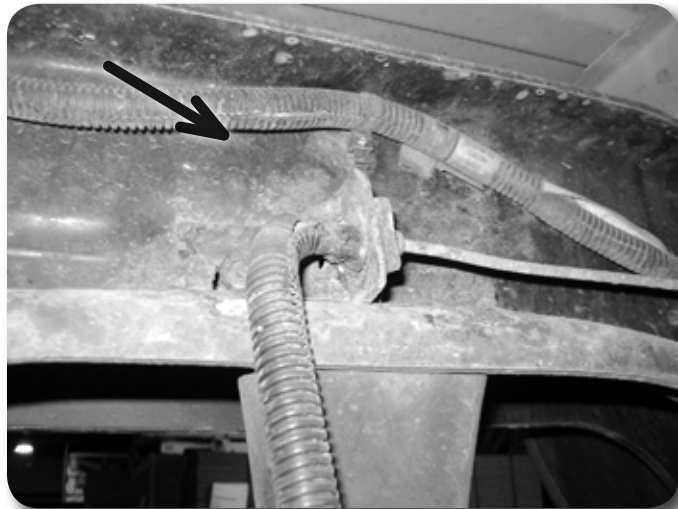

Figure 13

35. 2500 / 3500 models with rear brake proportioning valve and sway bar: A factory replacement bracket is available as well as extended sway bar links, these must be ordered separately. These were a rare option that is not commonly found on a majority of trucks.
36. Support rear axle with hydraulic jack.

37. Disconnect shock hardware and remove shocks from the vehicle. Keep hardware for new shock installation.
38. Work on one side of the vehicle at a time: Remove rear u-bolts, lower that side of the axle to remove the factory block. **Figure 14**



Figure 14

39. Clamp the factory leaf pack together with c-clamps. Remove the center pin and release the c-clamps. Insert new add-a-leaf into the leaf pack. **Figure 15**



Figure 15

40. Clamp the leaf pack together with c-clamp and insert new center pin through the entire pack. Do not use the center pin to draw the pack together. Snug the center pin nut.
41. Lower the axle and install new rear block. Install new u-bolts and snug at this time. Do not torque to specifications at this time. Figure 16

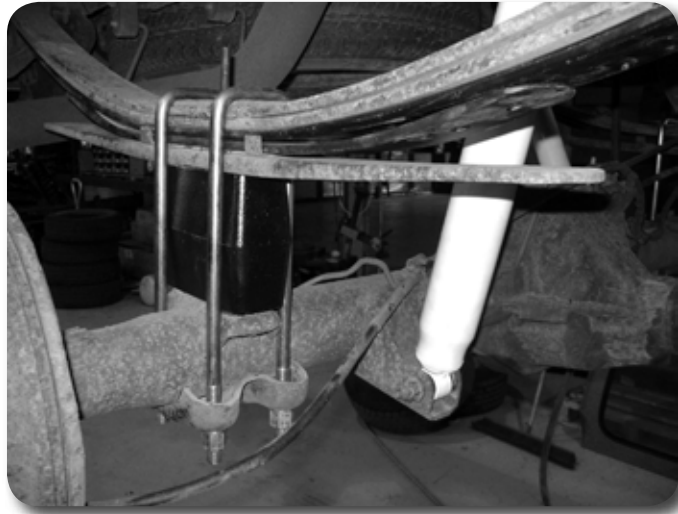

Figure 16

42. Repeat add-a-leaf and block installation on opposite side of vehicle.
43. Install new shocks with factory hardware. Tighten to 55 ft-lbs.
44. Install brakeline drop bracket at frame. Adjust to give adequate slack at full droop. Attach brakeline to relocation bracket. Figure 17



Figure 17

Post-Installation Warnings

1. Check all fasteners for proper torque. Check to ensure for adequate clearance between all rotating, mobile, fixed, and heated members. Verify clearance between exhaust and brake lines, fuel lines, fuel tank, floor boards and wiring harness. Check steering gear for clearance. Test and inspect brake system.
2. Perform steering sweep to ensure front brake hoses have adequate slack and do not contact any rotating, mobile or heated members. Inspect rear brake hoses at full extension for adequate slack. Failure to perform hose check/ replacement may result in component failure.
3. Perform head light check and adjustment.
4. Re-torque all fasteners after 500 miles. Always inspect fasteners and components during routine servicing.

45. Reinstall wheels and torque to factory specifications.
46. Lower vehicle to the ground, torque u-bolts to 95 ft-lbs.
47. Recheck all hardware for proper torque, check again after 500 miles and at regularly scheduled maintenance intervals.