

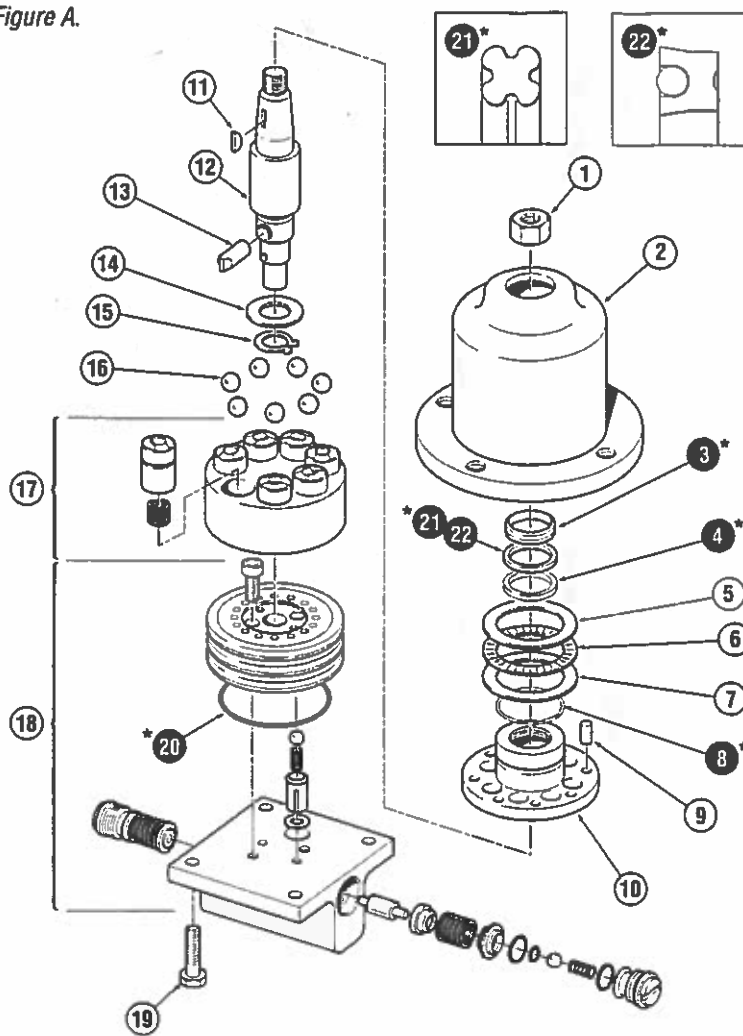

HELM SEAL KIT# HS-05 All Hynautic H-50 Series Helm Pumps

Figure A.



NOTICE

All helms made February 1986 and EARLIER use a single "quad ring" shaft seal (item 21).

All helms made March 1986 – DATE use a PolyPack type seal (item 22).

both of these seals are included in this kit

⚠ WARNING

These helm units are manufactured under strict controls and testing procedures. Disassembly of item 18, Valve Body Assembly, will void any existing warranty. If replacement is required please contact SeaStar Solutions.

NOTICE

When re-assembly of the helm is to be carried out, be sure to use the alignment procedure in figure B to ensure correct operation of your helm pump.

Figure B.

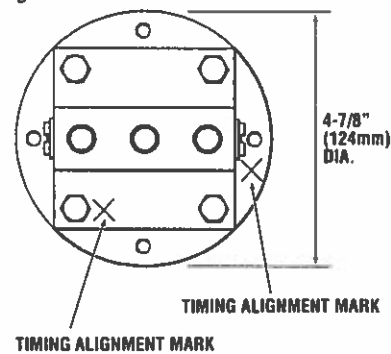

| ITEM | PART # | QTY | DESCRIPTION |
|------|--------|-----|----------------------|
| 1 | 270037 | 1 | Nut, 1/2" SS |
| 2 | 900604 | 1 | Helm Body |
| *3 | 700068 | 1 | Wiper |
| *4 | 224012 | 1 | Quad Ring |
| 5 | 190010 | 1 | Bearing Race "Thin" |
| 6 | 190011 | 1 | Bearing Thrust |
| 7 | 190009 | 1 | Bearing Race "Thick" |
| *8 | 211028 | 1 | O'Ring |
| 9 | 290146 | 1 | Pin |
| 10 | 620028 | 1 | Ball Cage |
| 11 | 260126 | 1 | Shaft Key |
| 12 | 400257 | 1 | Wheel Shaft |
| 13 | 650026 | 1 | Key |

| ITEM | PART # | QTY | DESCRIPTION |
|------|---------|-----|--|
| 14 | 215530 | 1 | Race |
| 15 | 300046 | 1 | Snap Ring |
| 16 | 234066 | 9 | Ball Bearing |
| 17 | 510070X | 1 | Cylinder Barrel Assy. – H-50 |
| | 510080X | 1 | For use with H-51 |
| | 510090X | 1 | For use with H-52 |
| 18 | 900230 | 1 | Valve Body Assembly |
| 19 | 112827 | 1 | Screw |
| *20 | 211040 | 3 | O'Ring |
| *21 | 224012 | 1 | Quad Ring (Feb. 1986 and older helms) |
| *22 | 224015 | 1 | PolyPack Seal (Mar. 1986 – DATE helms) |

* Items supplied in Seal Kit# HS-05

Air Purge Instructions 3-Line Pressurized Systems

IMPORTANT NOTE:

If Helm has a Filler Plug similar to this, **DO NOT USE these Instructions.** Use 2-Line System Instructions instead.

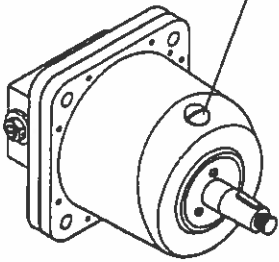

THESE SYSTEMS HAVE A SEPARATE PRESSURIZED RESERVOIR AND RELIEF VALVE. THE RELIEF VALVE MAY BE LOCATED ON THE BOTTOM OF THE RESERVOIR OR BY ITSELF IN THE REAR OF THE BOAT.

Reservoir (reservoir w/relief valve)

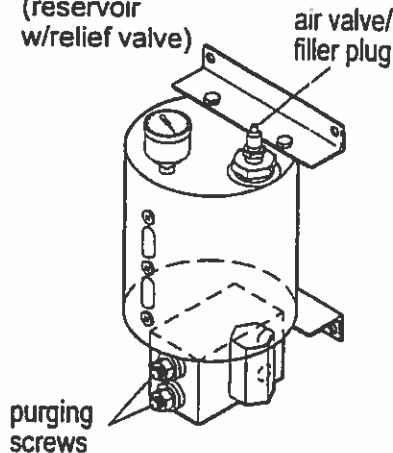

Relief Valve

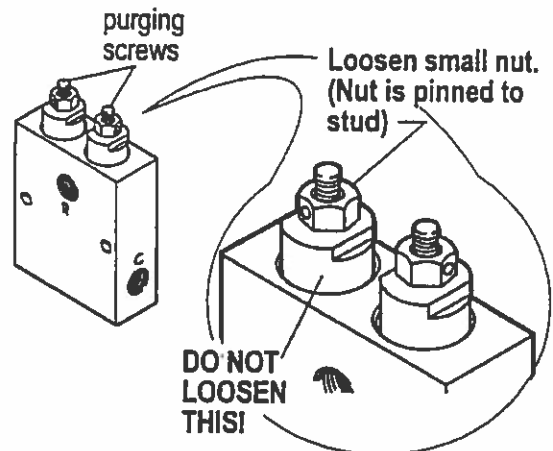

USE HYNAUTIC STEERING FLUID MCO-06

1. Locate the 2 Purging Screws with the pinned $\frac{1}{2}$ " brass nuts. (On separate Relief Valve, screws are located on top; on Relief Valve mounted under Reservoir, screws are located in front.) Loosen these 2 nuts and back off by hand, turning counterclockwise until they stop. **DO NOT FORCE!**
2. Remove the Hex Plug from the top of the Reservoir and fill with fluid $\frac{2}{3}$ - $\frac{3}{4}$ full; replace the Hex Plug. Never let the fluid level drop lower than 2" from the bottom of the Reservoir.
3. The Reservoir is equipped with a tire-type air valve so that any tire air pump or compressed air supply can be used to pressurize the system. Slowly pressureize the Reservoir to 35 - 40 PSI. As pressure is applied, fluid will flow into the system. Refill and repressurize as necessary. **DO NOT EXCEED 50 PSI.**
4. At the highest helm, bleed the air out of the Port (P) and Starboard (S) lines by opening the hose fitting connections, one at a time and allowing the air to escape until fluid appears; then retighten fittings.
5. Disconnect the Clevis or rod end of the Cylinder from its engine or rudder mounting if at all possible, making certain it is free to stroke without interference.
6. Bleed both ends of the Cylinder by backing off the socket-head cap screw Bleeders 1 turn. If the Cylinder is not equipped with Bleeders, open the hose fitting



connections, one at a time. Allow the air to escape until fluid appears, then close.

7. Verify that the Reservoir is at least $\frac{3}{4}$ full and the gage reads between 35 and 40 PSI. Never allow fluid level in Reservoir to drop below 2".
8. The following procedure will remove the air from the system and fill it with fluid: Go to the highest helm and turn the wheel slowly (2-3 seconds per revolution) 60 times in one direction. Check Reservoir level frequently.
9. Repeat Step 8 at each successively lower helm and autopilot. (Purging air from the autopilot is accomplished by setting a course on the autopilot to the same direction you are steering the helms and allowing the pilot to run for about 1 minute.)
10. Repeat Steps 6 and 7.
11. Go to the highest helm and turn the wheel in the opposite direction 60 times.
12. Repeat Step 11 at each successively lower helm as in Step 9.
13. Close the 2 Relief Valve Screws, with pinned hex nuts, by hand, turning clockwise, and snug with wrench. **Do not over tighten!**
14. Reattach the Cylinder to the Engine or Tiller Arm. Reservoir should be $\frac{2}{3}$ to $\frac{3}{4}$ full. Adjust the pressure to 25 - 30 PSI.

FOR HYDRAULIC FLUID AND SERVICE PARTS...

CALL: IN NORTHERN USA 1-800-247-6324
IN SOUTHERN USA 1-800-814-7070