

Instructions / Instructions De Montage / Instrucciones

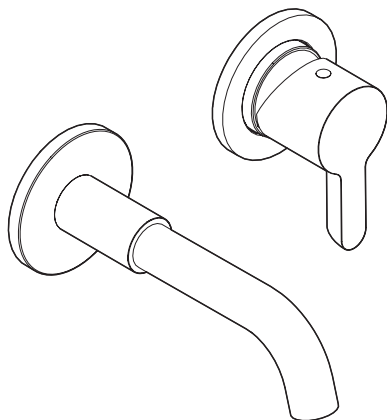

R411BU

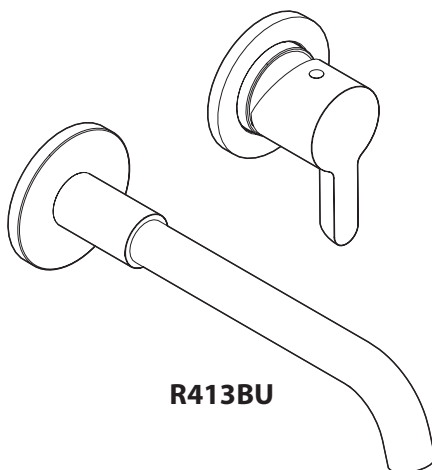

R413BU

R411BU

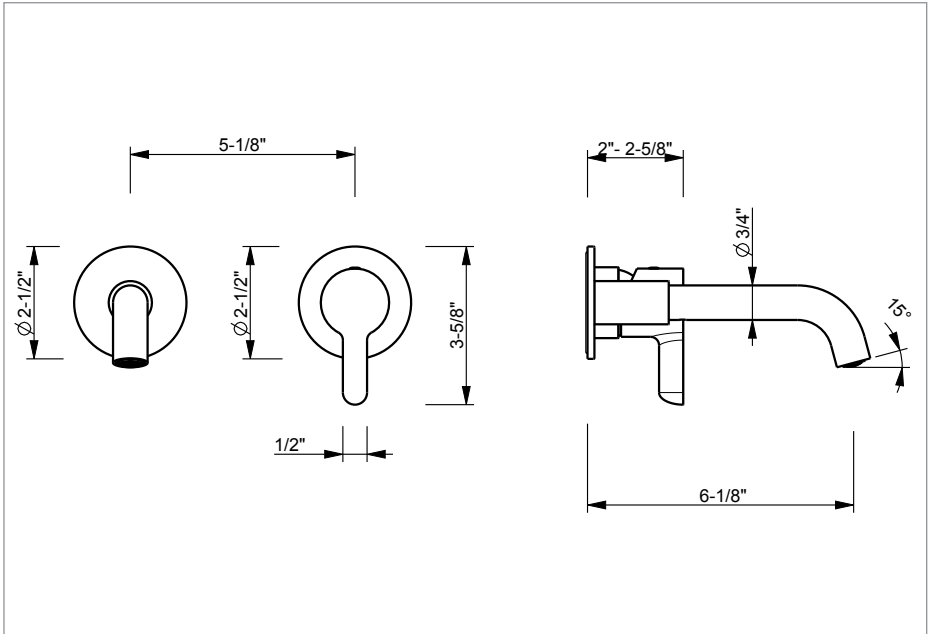

R413BU

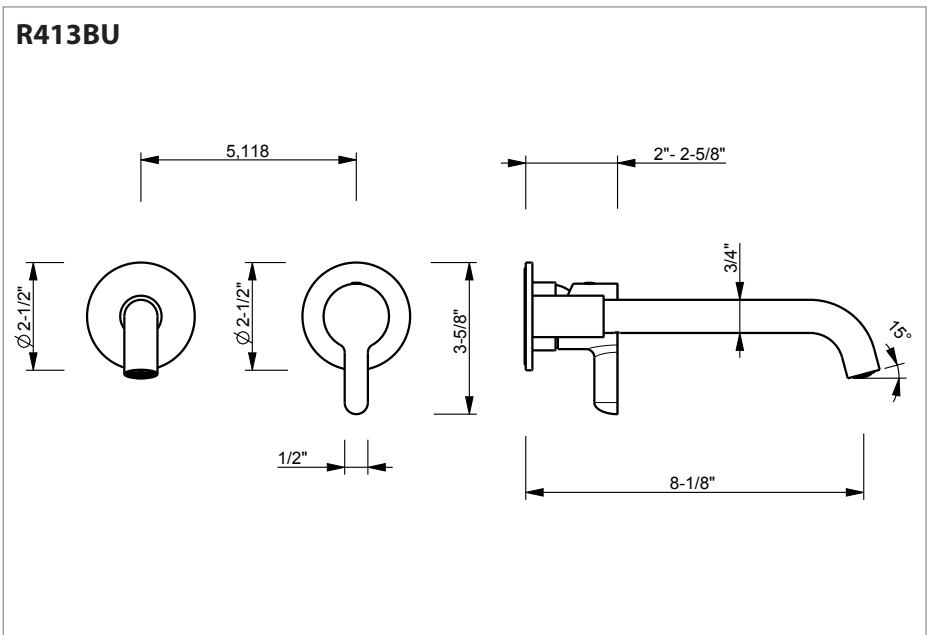

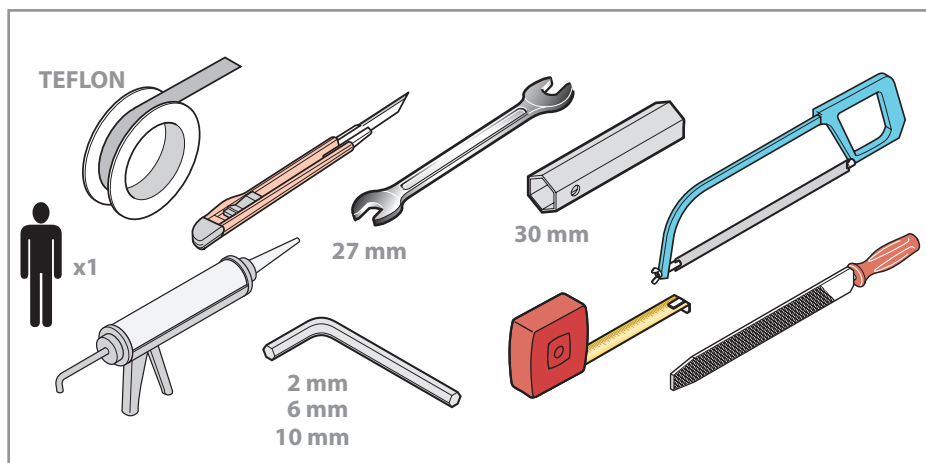

EN	FR	ES	
Minimum pressure	Pression minimum	Pression mínima	1 BAR
Maximum pressure	Pression maximum	Pression máxima	10 BAR
Recommened working pressure	Pression optimale de service	Pression de trab. aconsejada	2-5 BAR
Max. water temperature	Température maximum	Temperatura máxima	80° C 176° F
Maximum in-let pressure dif- ference (hot - cold) 1.5 BAR	Différence max. de pression d'arrivée (chaud - froid)	Diferencial max. de presiùn de entrada (caliente - fria)	1.5 BAR

EN If water pressure is above 5 bar, it is advisable to install a flow restrictor upstream of the water supply to avoid vibrations and regulate temperature.

FR Si la pression de l'eau est supérieure à 5 bar, il est recommandé d'installer un réducteur de pression en amont de l'alimentation afin d'éviter toute vibration et régulariser le réglage de la température.

ES Si la presión del agua supera los 5 bar, es preferible instalar un limitador de caudal en la conducción de la alimentación para evitar vibraciones y normalizar la regulación de la temperatura.

PT Se a pressão da água for superior a 5 bar, é preferível instalar um redutor de pressão antes do abastecimento para evitar vibrações e tornar a regulação da temperatura regular.

EN These mixers can be used with high-pressure hot water accumulators or with instant water heaters.

FR Ces mitigeurs peuvent être utilisés avec des accumulateurs d'eau chaude à pression ou avec des chauffe-eau instantanés.

ES Estos monomandos pueden utilizarse con acumuladores de agua caliente a presión o con calentadores instantáneos.

1

R411BU
R413BU

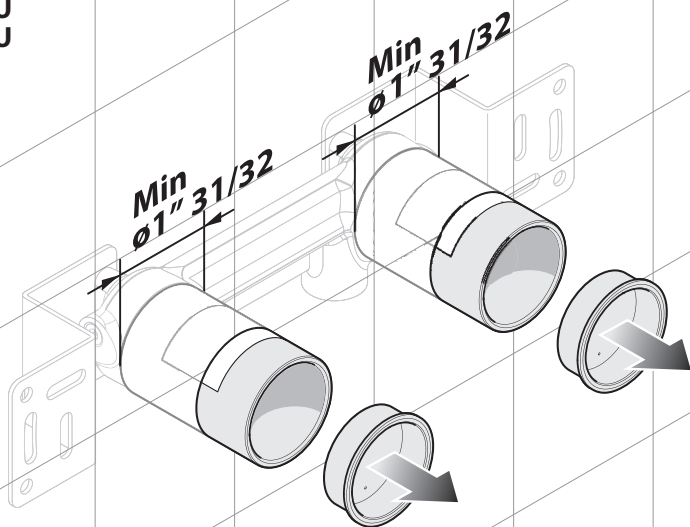

2

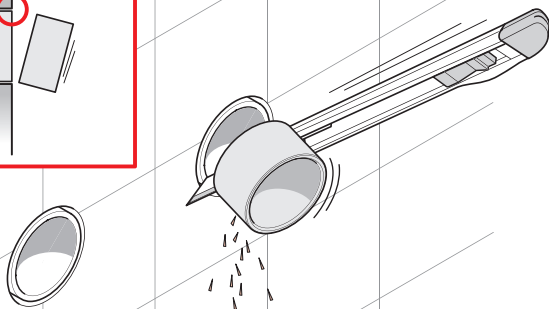
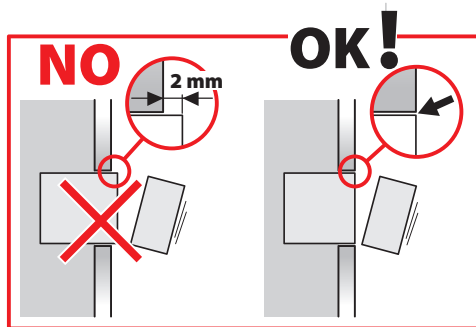

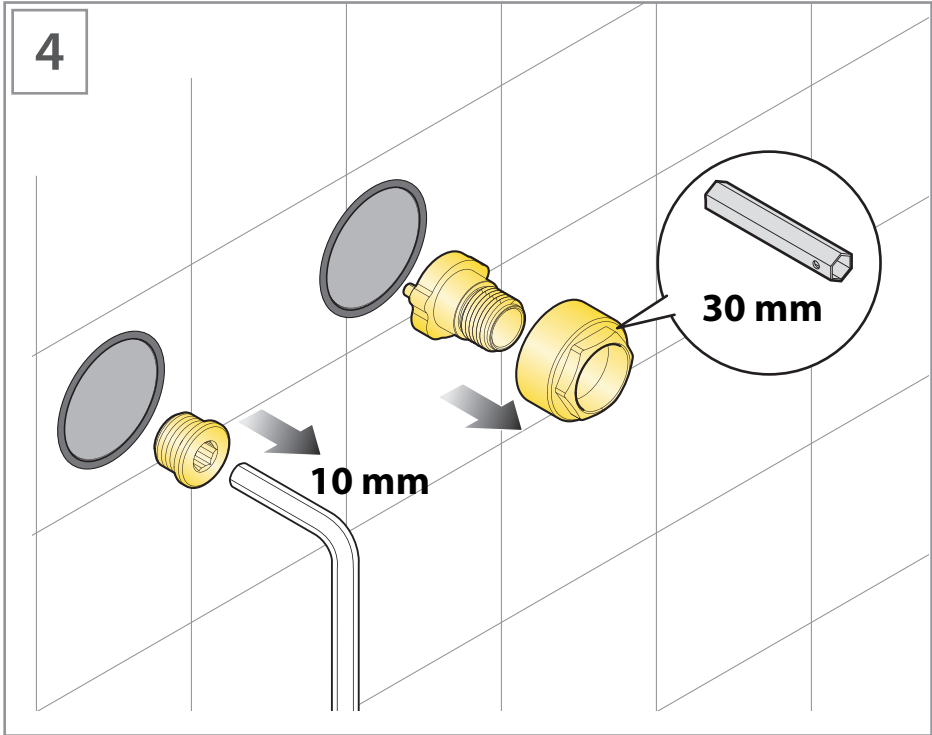
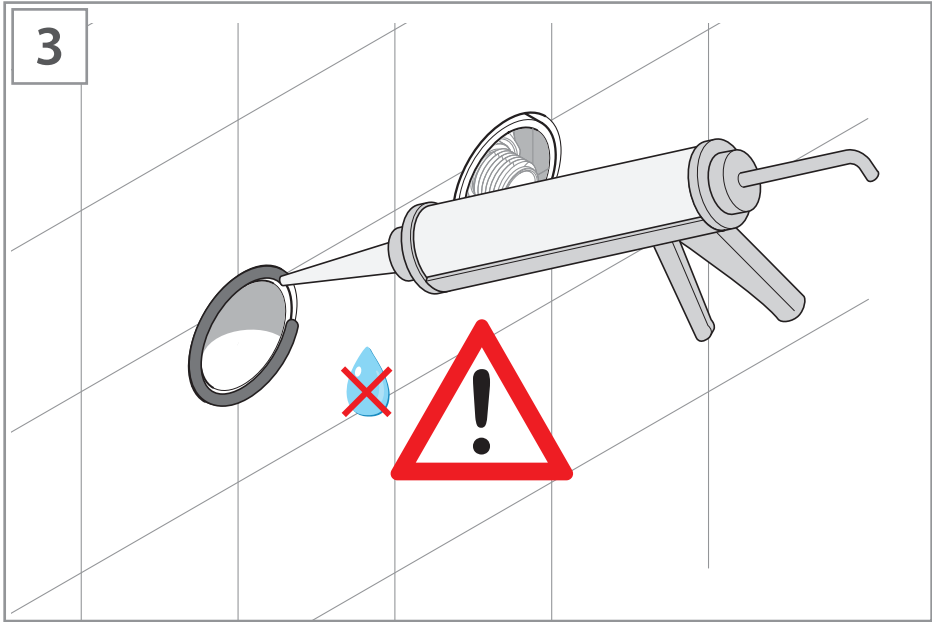

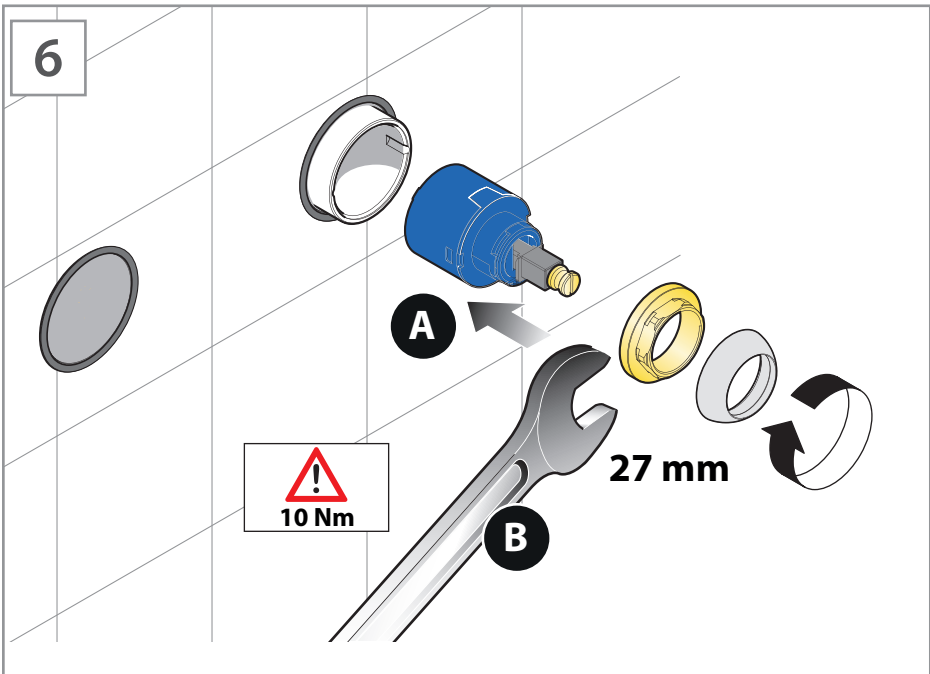
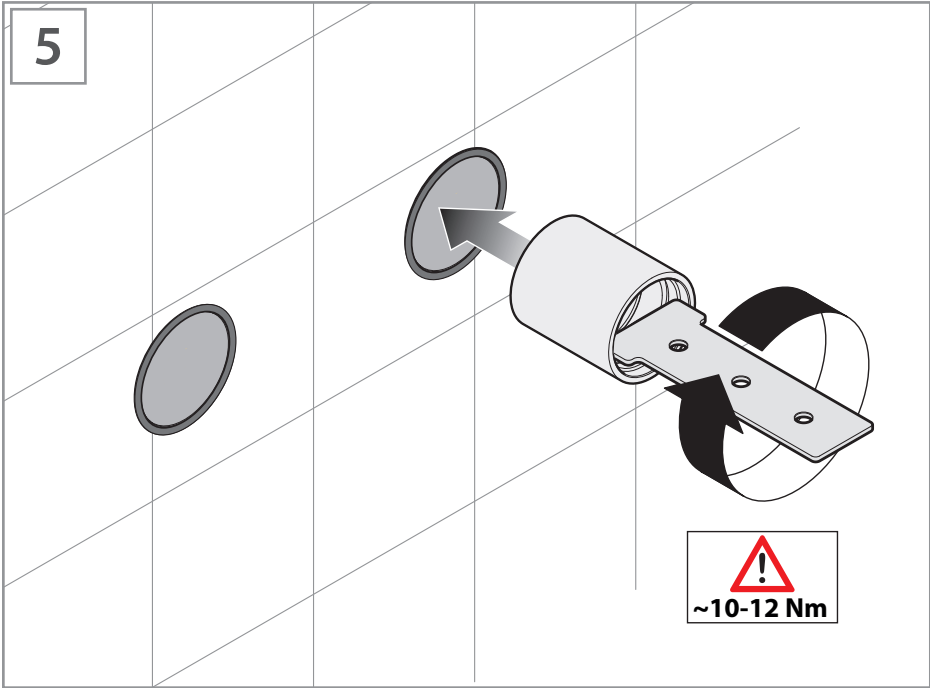

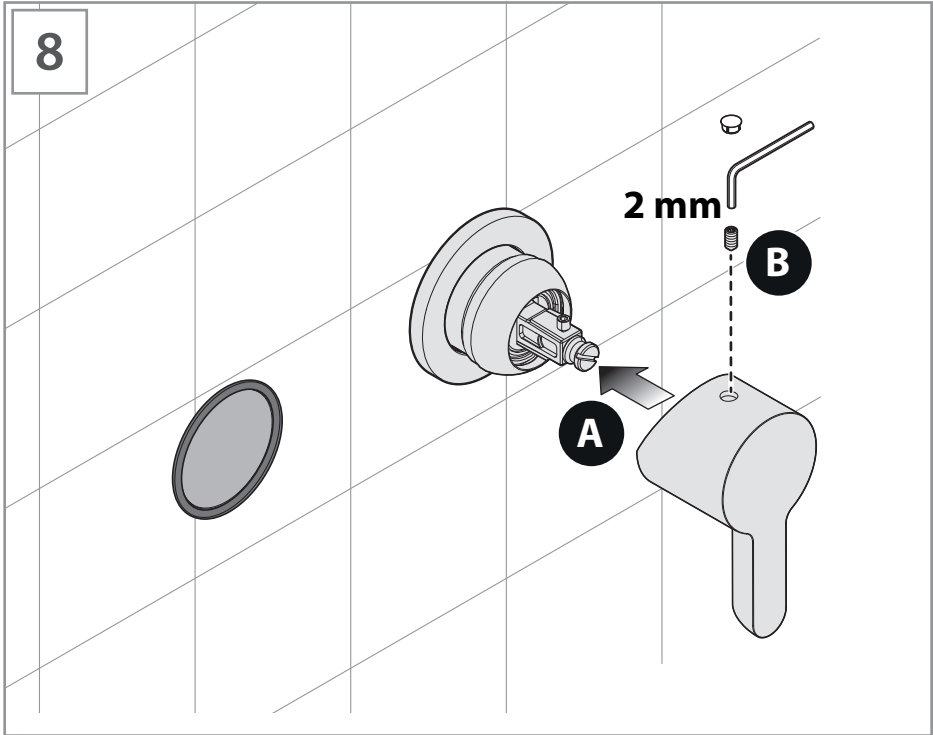
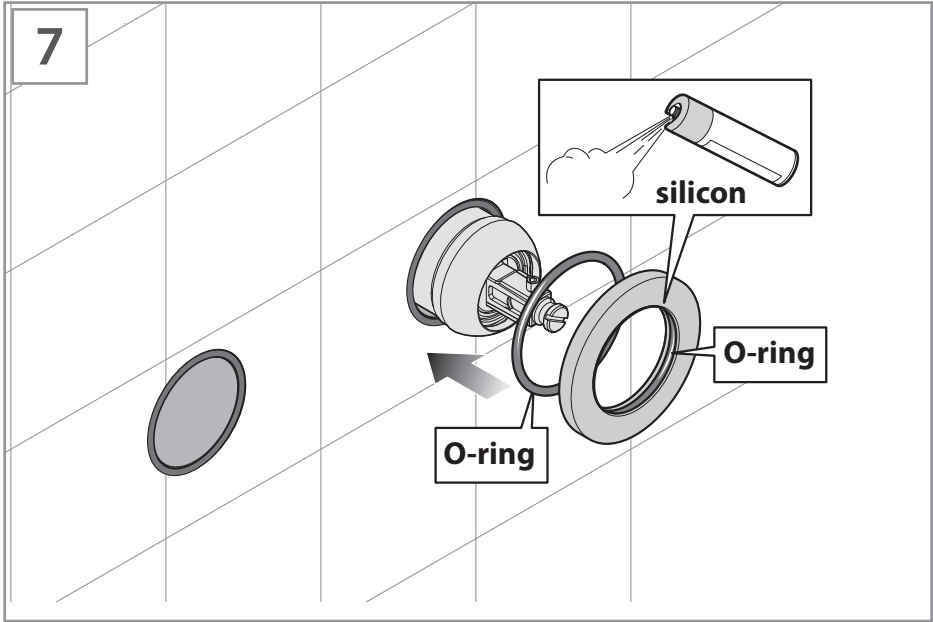



9

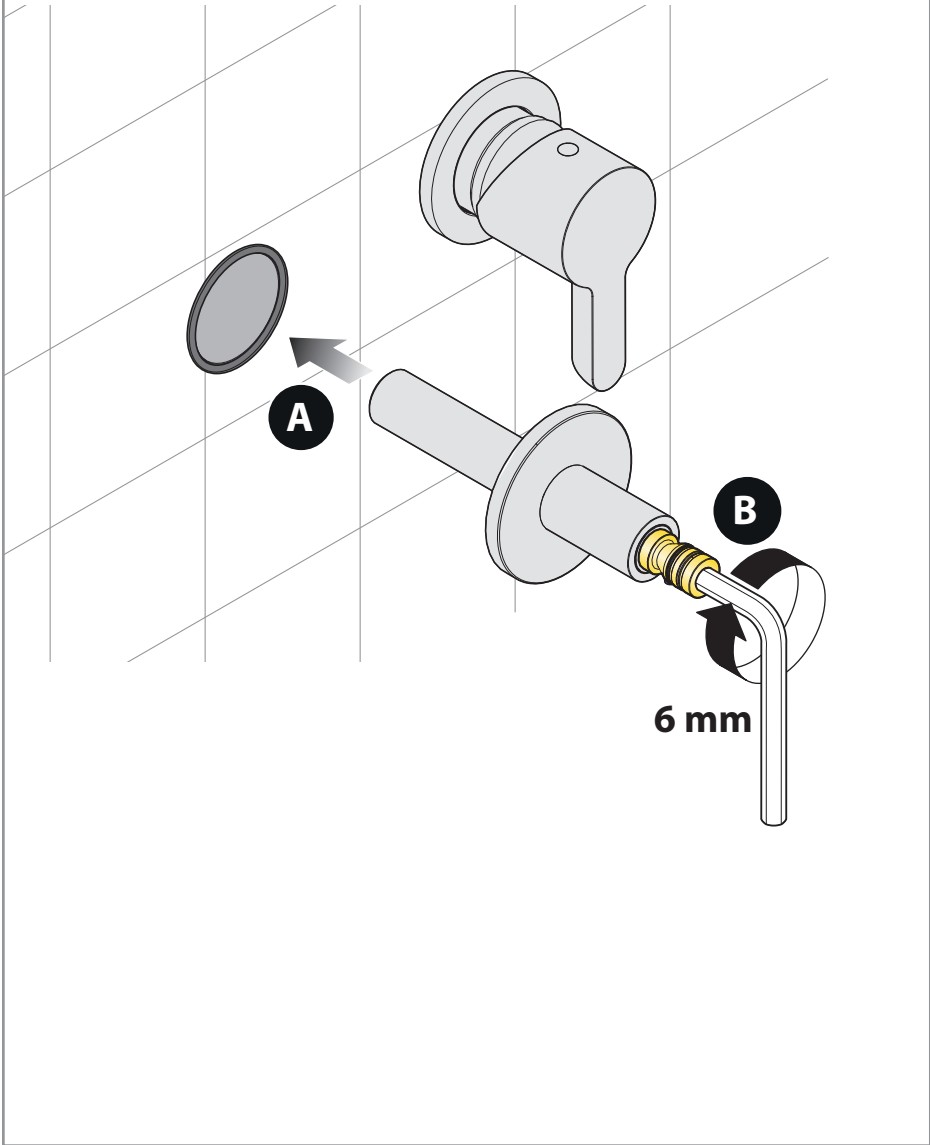

10

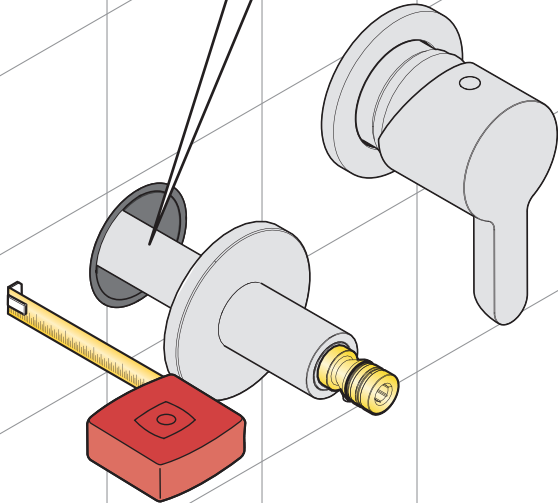
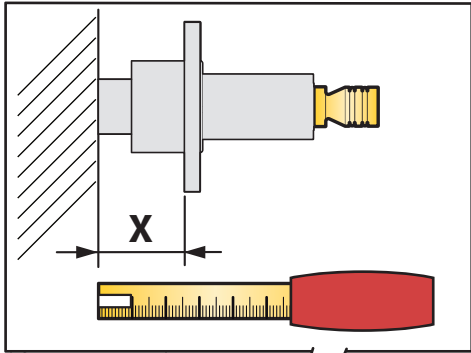



11

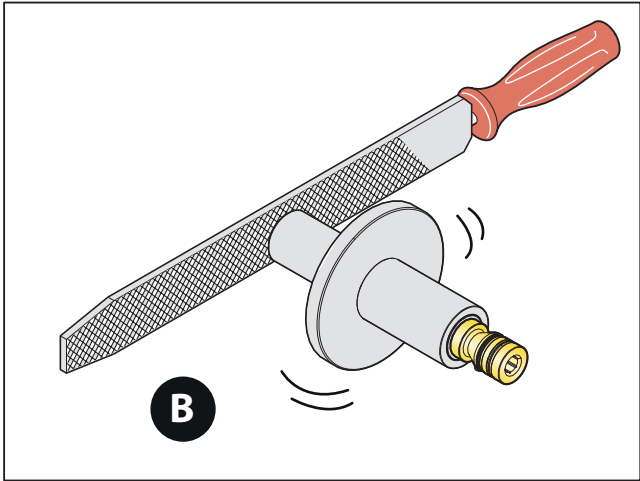
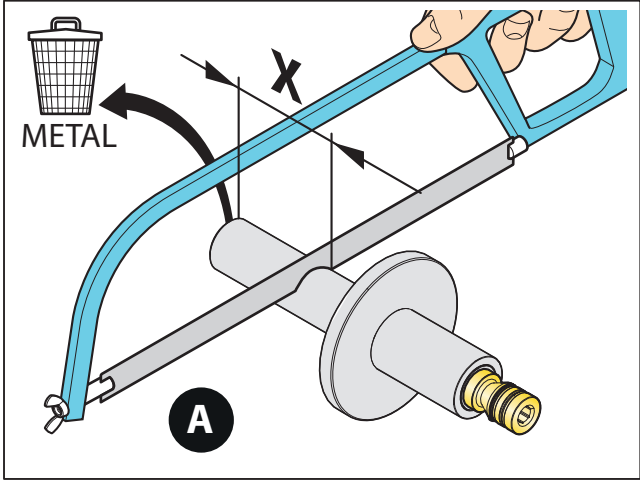

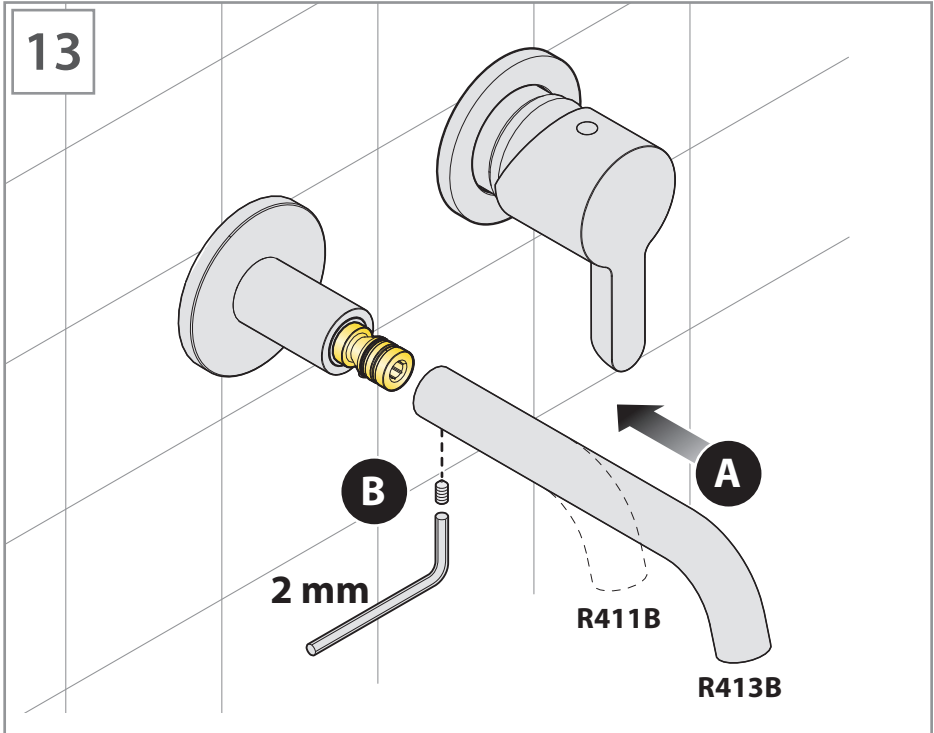
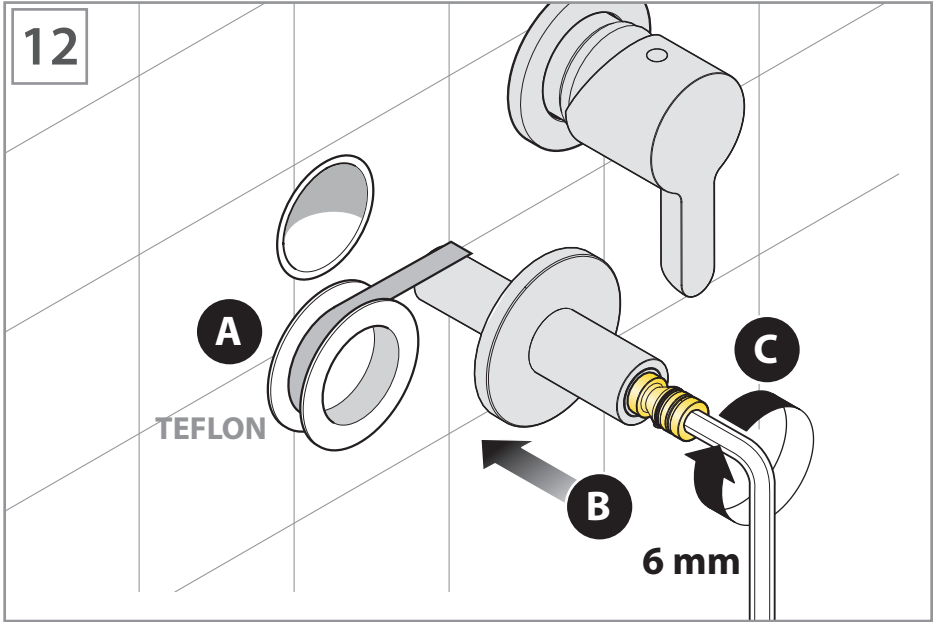

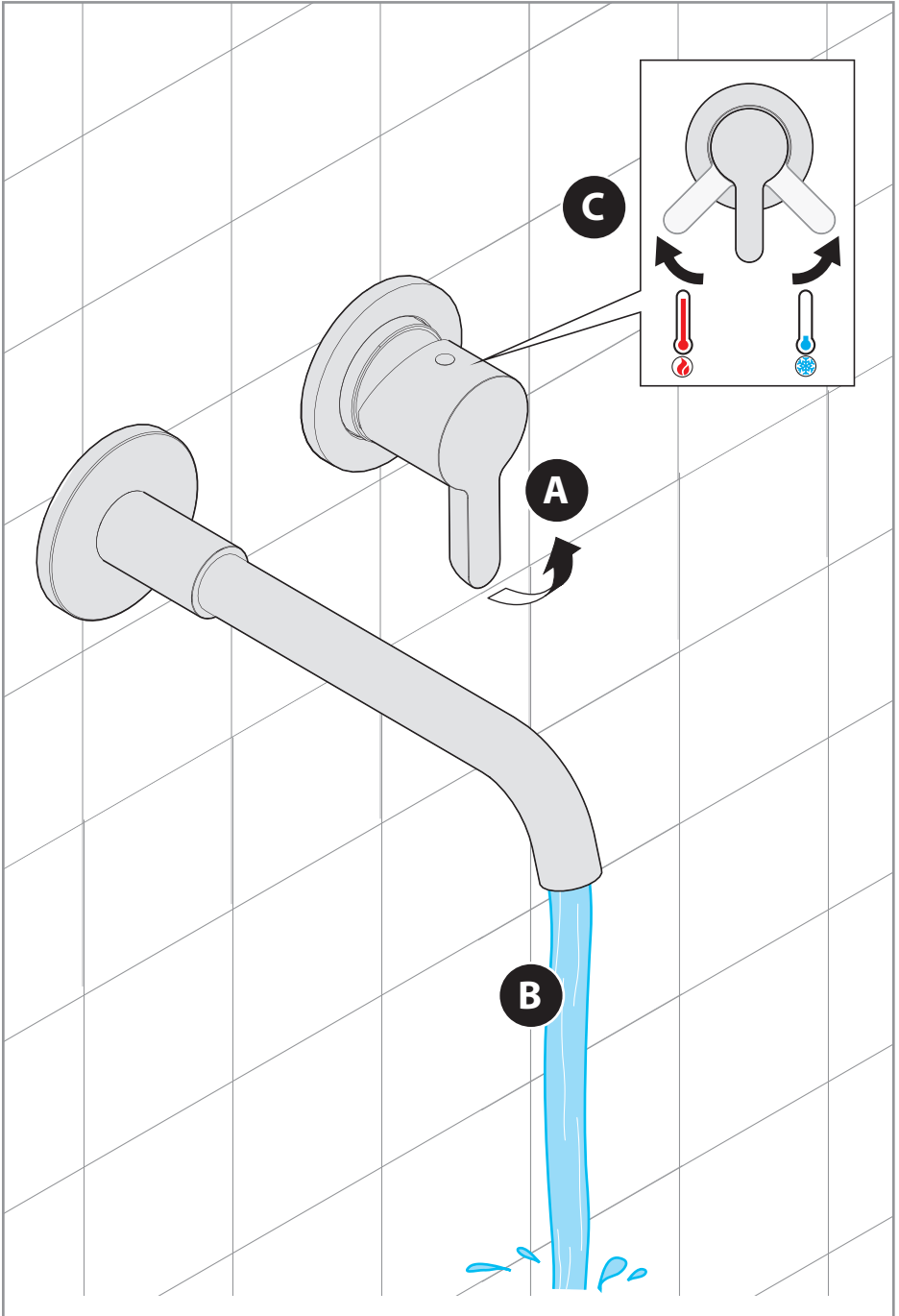

EN On first use or following prolonged periods of inactivity, do not use the first half-litre of drinking water dispensed. Shut off the plumbing system in the event of a long absence.

Check the water-tightness regularly.

FR Lors de la première utilisation ou après une longue période de non utilisation, ne pas consommer le premier demi-litre d'eau potable qui sort du robinet. Fermer l'installation hydraulique en cas d'absence prolongée.

Contrôler périodiquement l'étanchéité.

ES Durante el primer uso o tras un largo periodo de inactividad, no consumir el primer medio litro de agua potable que salga del grifo. Cerrar la instalación de agua si va a estar ausente durante un largo periodo. Comprobar

periódicamente que no haya pérdidas

- EN** Clean the surfaces using a soft cloth soaked in liquid soap diluted in water, then rinse and dry thoroughly.
Never use detergents containing abrasive substances or containing muriatic acid, vinegar, ammonia, acetone, bleach, domestic acids, disinfectants in general or abrasive sponges. **CAUTION!** The use of products other than those recommended may damage the surfaces irreparably, in which case the manufacturer will not be held liable.
If the flow rate decreases, clean or replace the aerator.
- FR** Nettoyer les surfaces avec un chiffon doux imbibé de savon liquide dilué dans l'eau : à la fin, rincer et essuyer avec soin. Ne jamais utiliser de détergents contenant des substances abrasives ou à base d'acide chlorhydrique, vinaigre, ammoniaque, acétone, eau de javel, acides à usage domestique, désinfectants divers, ni d'éponges abrasives. **ATTENTION !** L'emploi de produits non conseillés peut détériorer irrémédiablement la surface des articles pour lesquels le fabricant ne sera pas responsable. Au cas où la sortie d'eau diminuerait, nettoyer ou remplacer l'aérateur.
- ES** Las superficies deben limpiarse con un paño suave y jabón líquido diluido en agua: al finalizar, aclare y seque con cuidado. No utilizar en ningún caso detergentes que contengan sustancias abrasivas o a base de ácido clorhídrico, vinagre, amoníaco, acetona, lejía, ácidos de uso doméstico, desinfectantes varios o esponjas abrasivas.
¡ATENCIÓN! El uso de productos no recomendados puede ocasionar un deterioro irreparable de las superficies, en cuyo caso el fabricante no se responsabilizará de los daños.
Si disminuye el caudal de agua suministrado, limpiar o cambiar el aireador.





Fratelli Fantini SpA

via Buonarroti, 4
Pella (NO) Italia
T +39 0322 918411 r.a.
F +39 0322 969530
fantini@fantini.it
www.fantini.it

