

# ABOUTWATER AK/25

Instructions / Instructions De Montage / Instrucciones

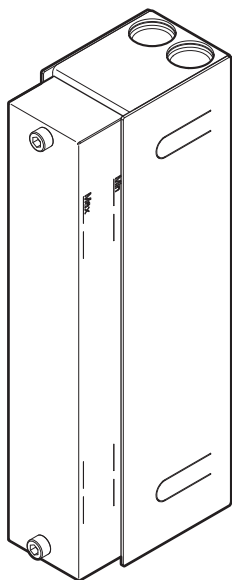

ART. T068AU

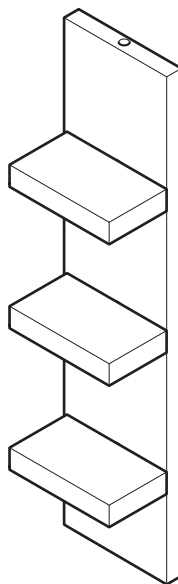

ART. T068BU

Tools needed / Outils nécessaires / Instrumentos necesarios

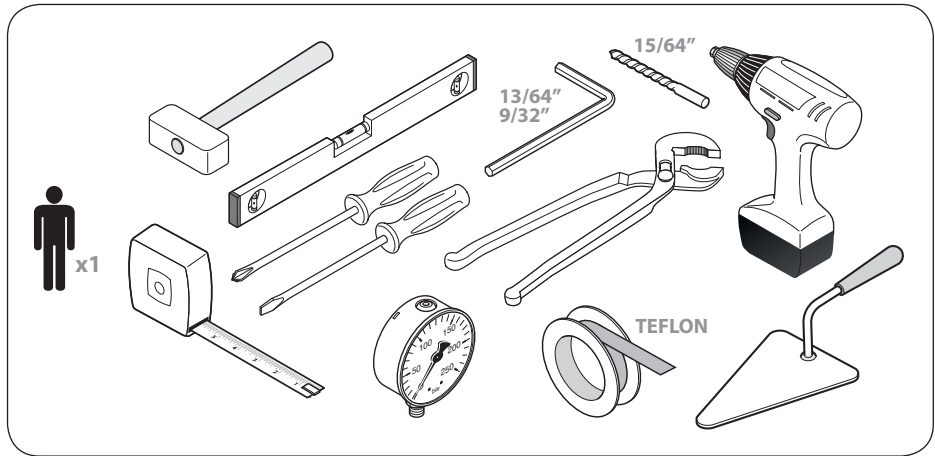

Index / Index / Índice

T068AU .....	6
T068BU .....	18

ART. T068BU - T068AU

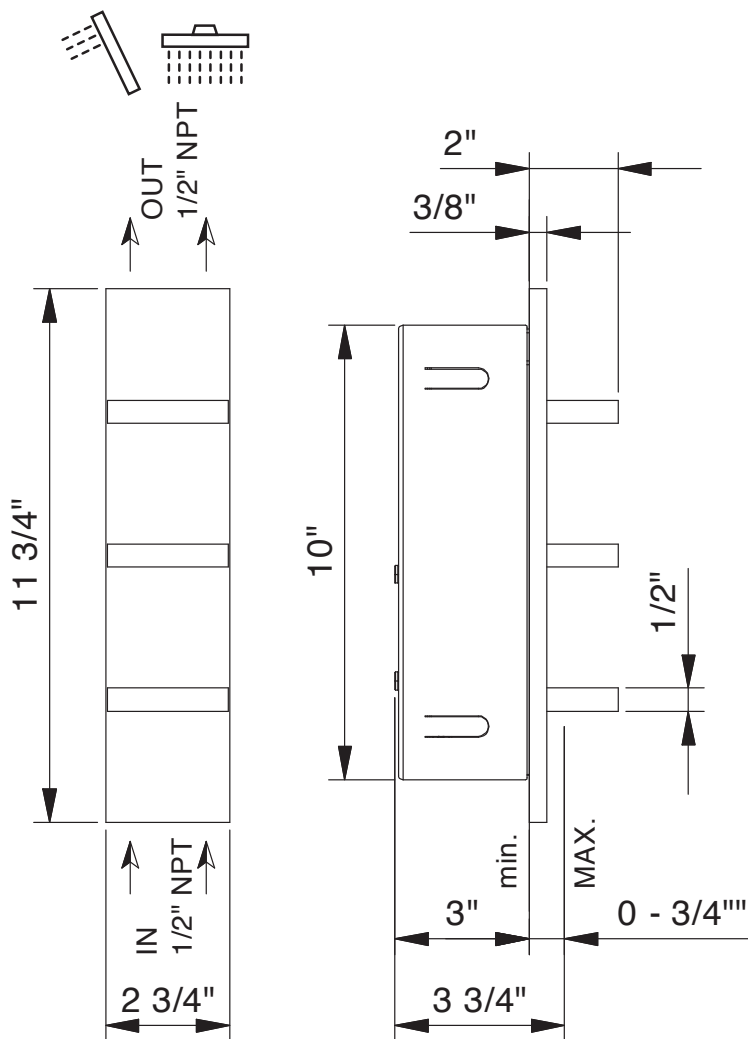

**Technical data**

Minimum pressure	1 BAR
Maximum pressure	10 BAR
Reccomended working pressure	2-5 BAR
Maximum water temperature	80°
Maximum water temperature reccomended	65°
Maximum in-let pressure difference (hot - cold)	1.5 BAR

**Operating instructions**

These mixers can be used with cumulos boilers or instantaneous water heaters.

**Warning**

The supplying pipes must be carefully cleaned before installation.

Remember that the hot water supply must **ALWAYS** be connected to the tube on the **LEFT**.

ENGLAND.**Caractéristiques techniques**

Pression minimum	1 BAR
Pression maximum	10 BAR
Pression optimale de service	2-5 BAR
Température maximum	80°
Température maximum optimale	65°
Différence maximum de Pression d'arrivée (chaud - froid)	1.5 BAR

**Mode d'emploi**

Ces mitigeurs peuvent être utilisés avec accumulateurs d'eau chaude à pression ou avec des chauffe-eau instantanés.

**Note**

Il est indispensable que les raccords d'alimentation soient purgés avant la mise en place de l'appareil.

Se rappeler que l'eau chaude doit être **TOUJOURS** liée au petit tuyau ou au flexible de **GAUCHE**.

FRANCE.**Datos Técnicos**

Pression mínima	1 BAR
Pression máxima	10 BAR
Pression de trabajo aconsejada	2-5 BAR
Temperatura máxima	80°
Temperatura máxima aconsejada	65°
Diferencial maxima de presión de entrada (caliente - fria)	1.5 BAR

**Aplicaciones**

Estos monomandos pueden ser utilizados con acumuladores de agua caliente a presión.

**Advertencias**

Antes de conectar el monomando es necesario purgar correctamente la instalación hidráulica de alimentación de cualquier impureza que pueda tener.

Recuerde que el agua caliente debe ser **SIEMPRE** conectada al tubo o flexo de la **IZQUIERDA**.

SPAIN.

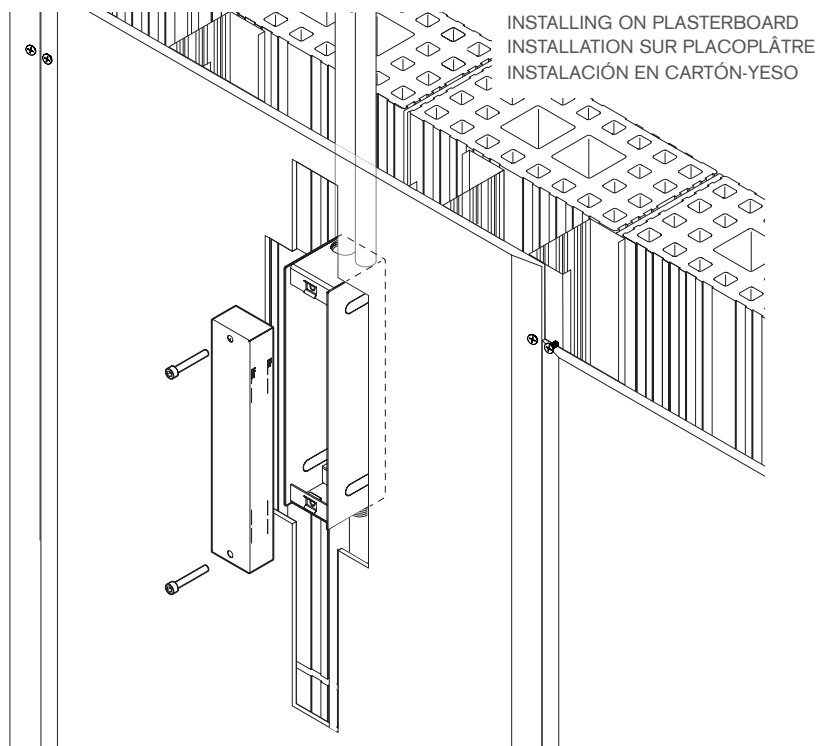
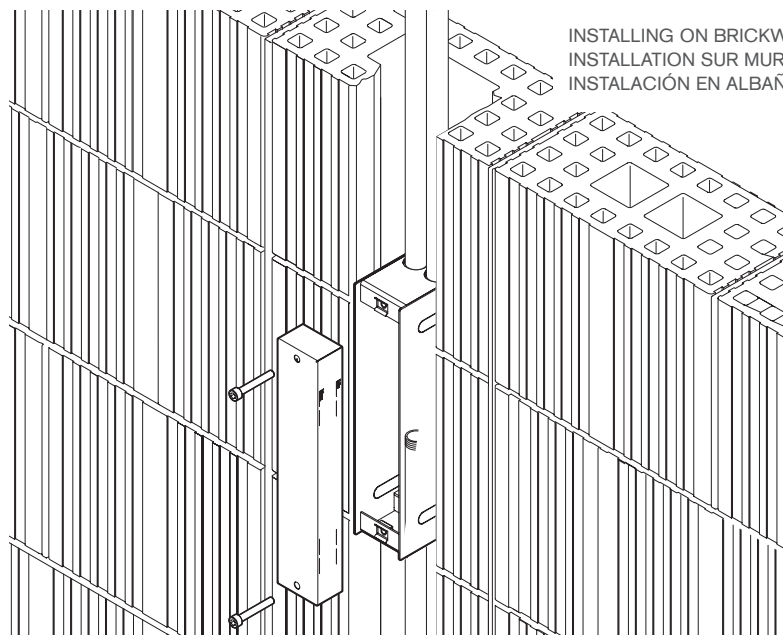

1.

INSTALLING ON BRICKWORK  
 INSTALLATION SUR MUR  
 INSTALACIÓN EN ALBAÑILERÍA

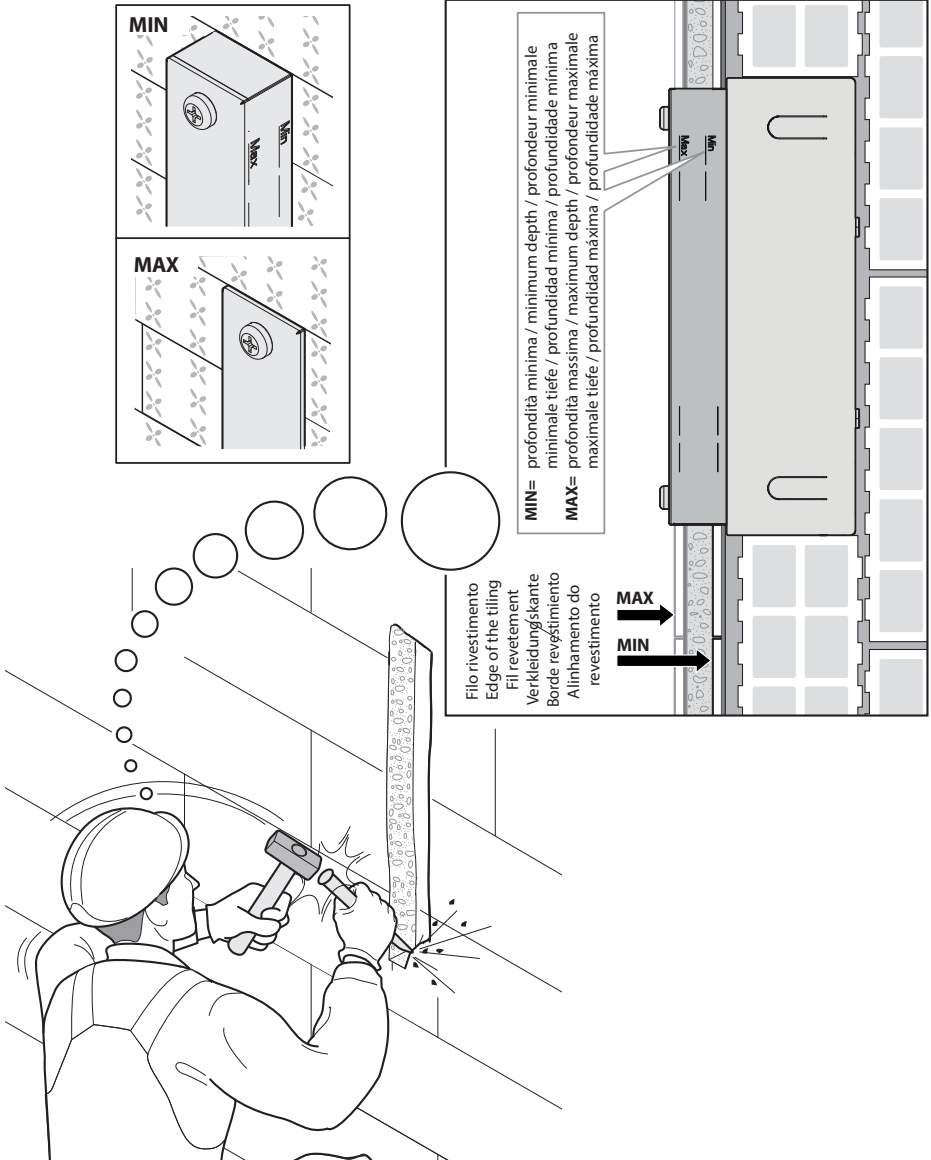

2.

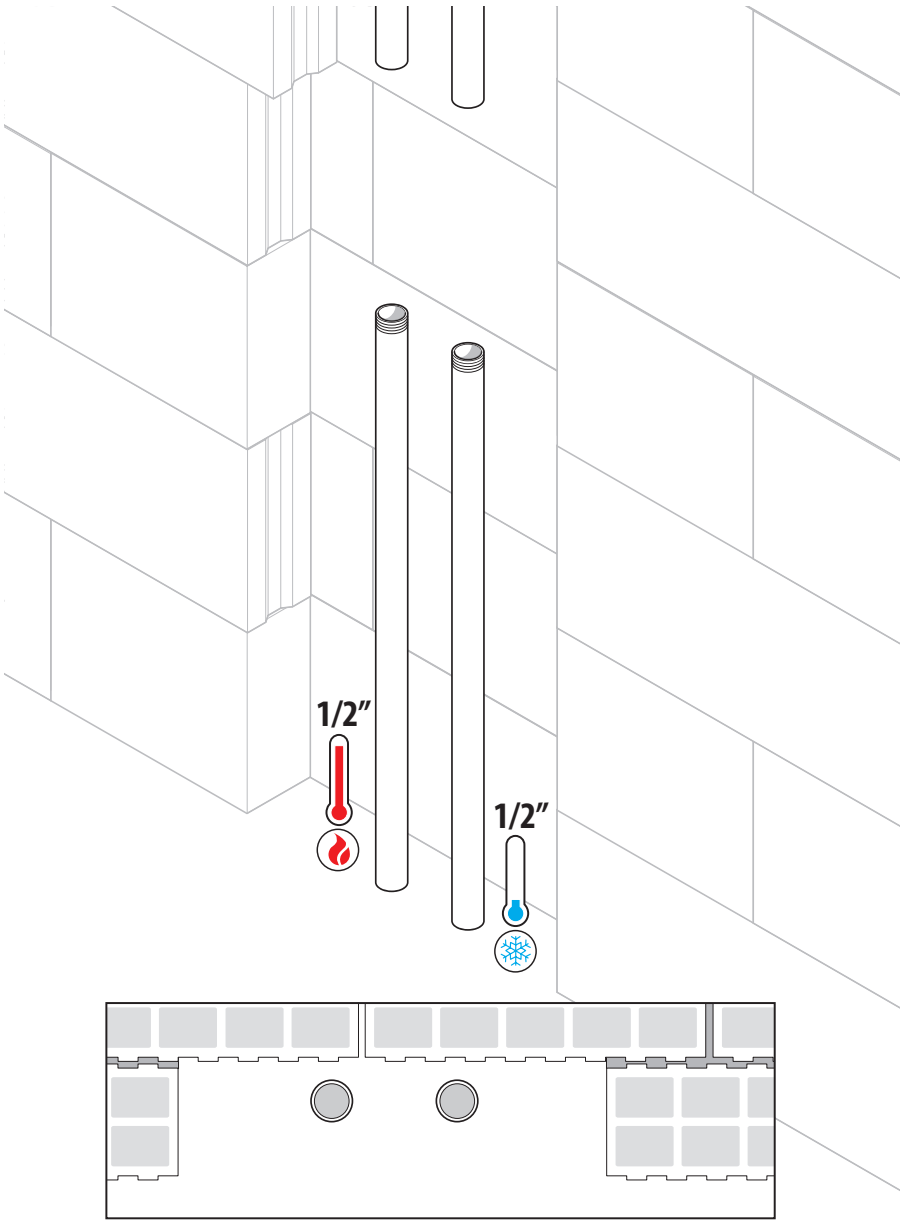

3.

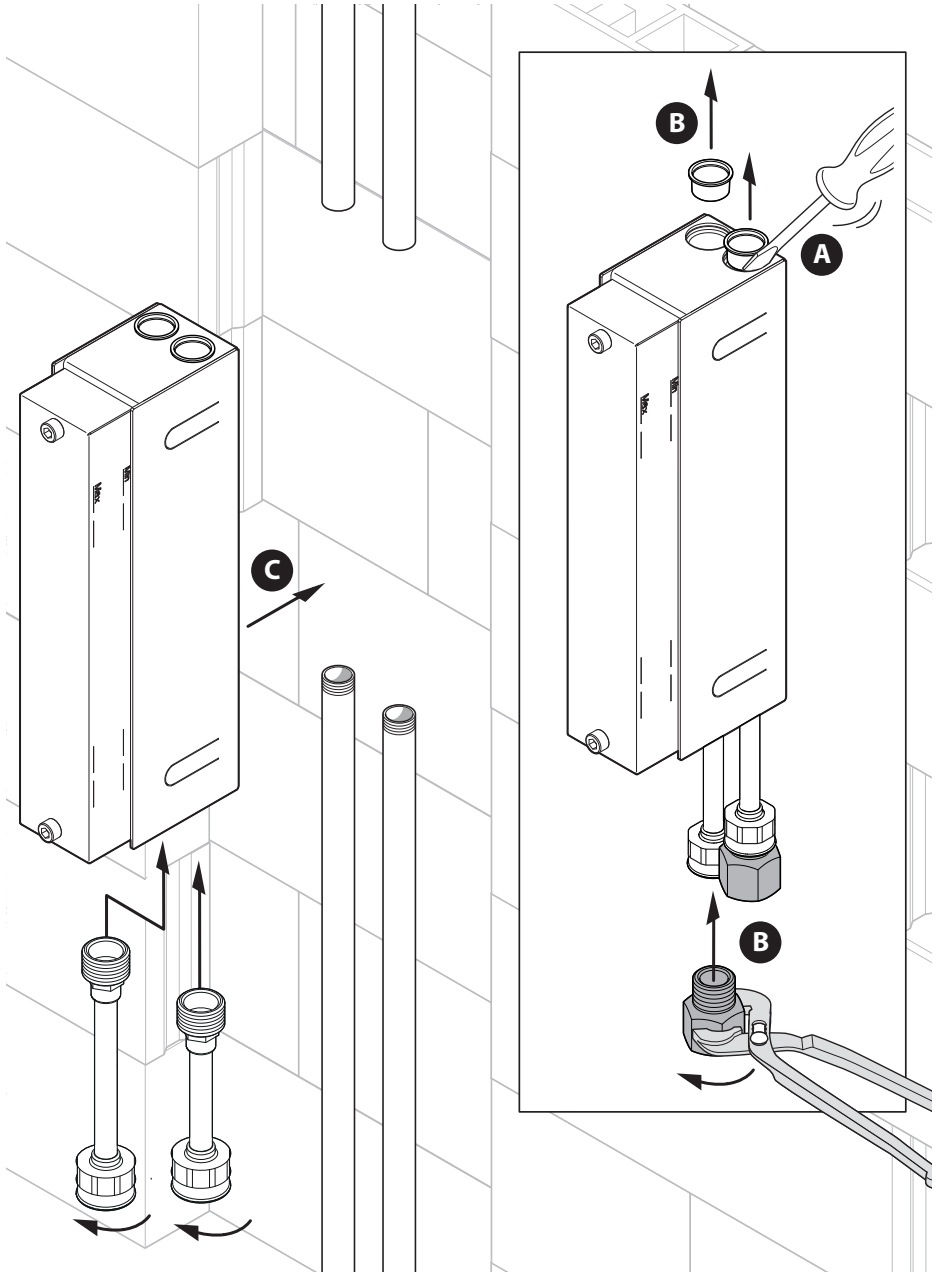



4.

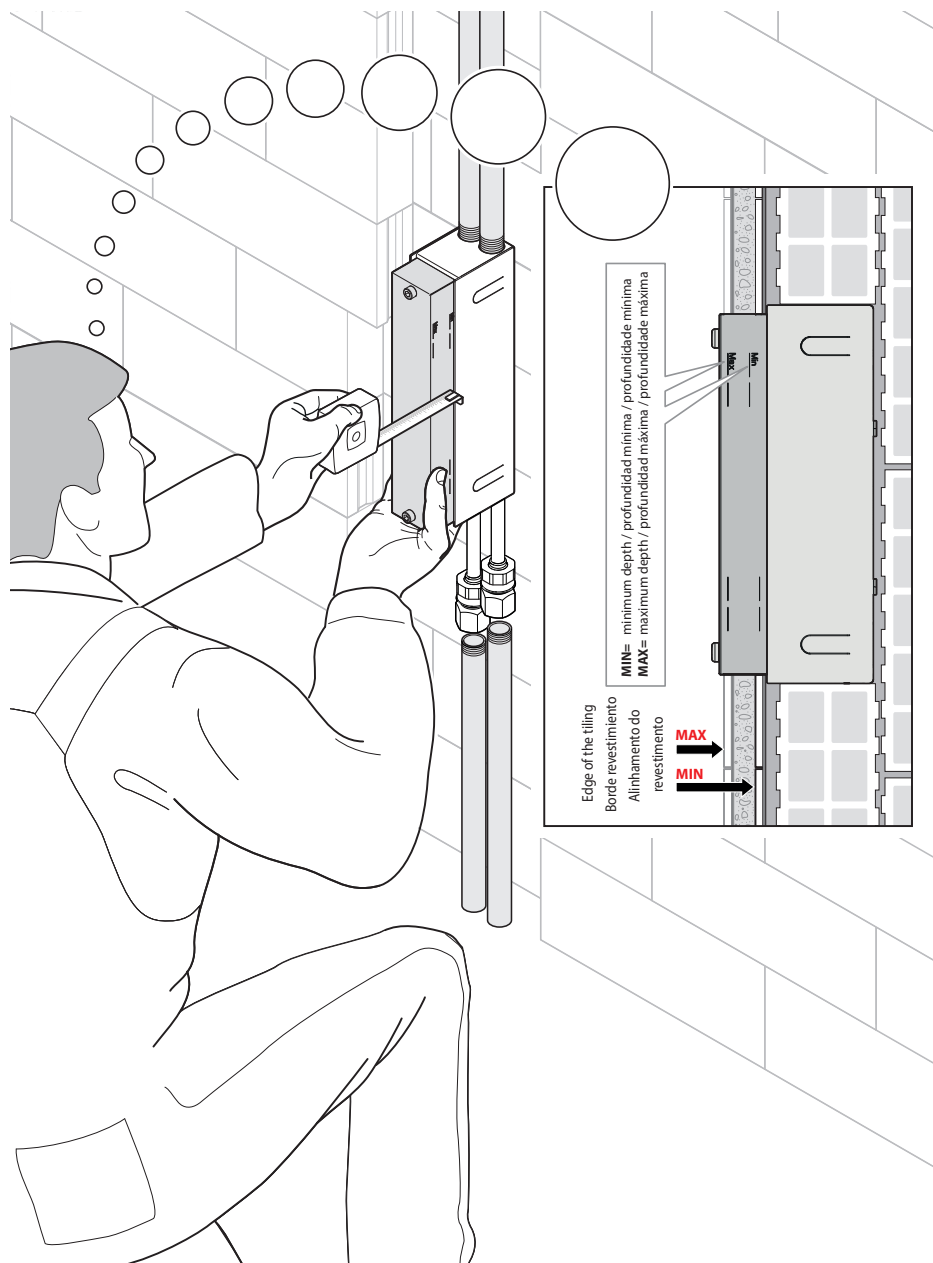

5.

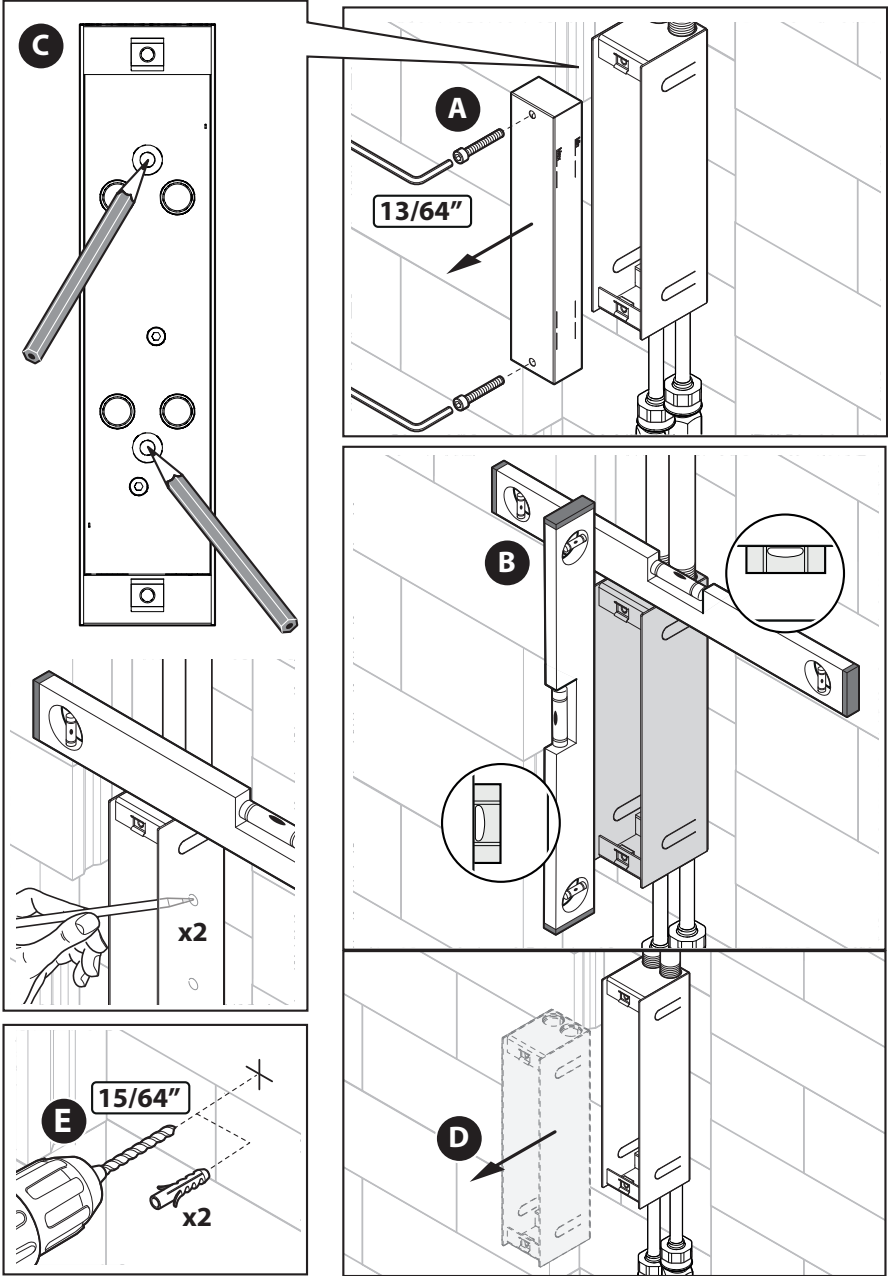

6.

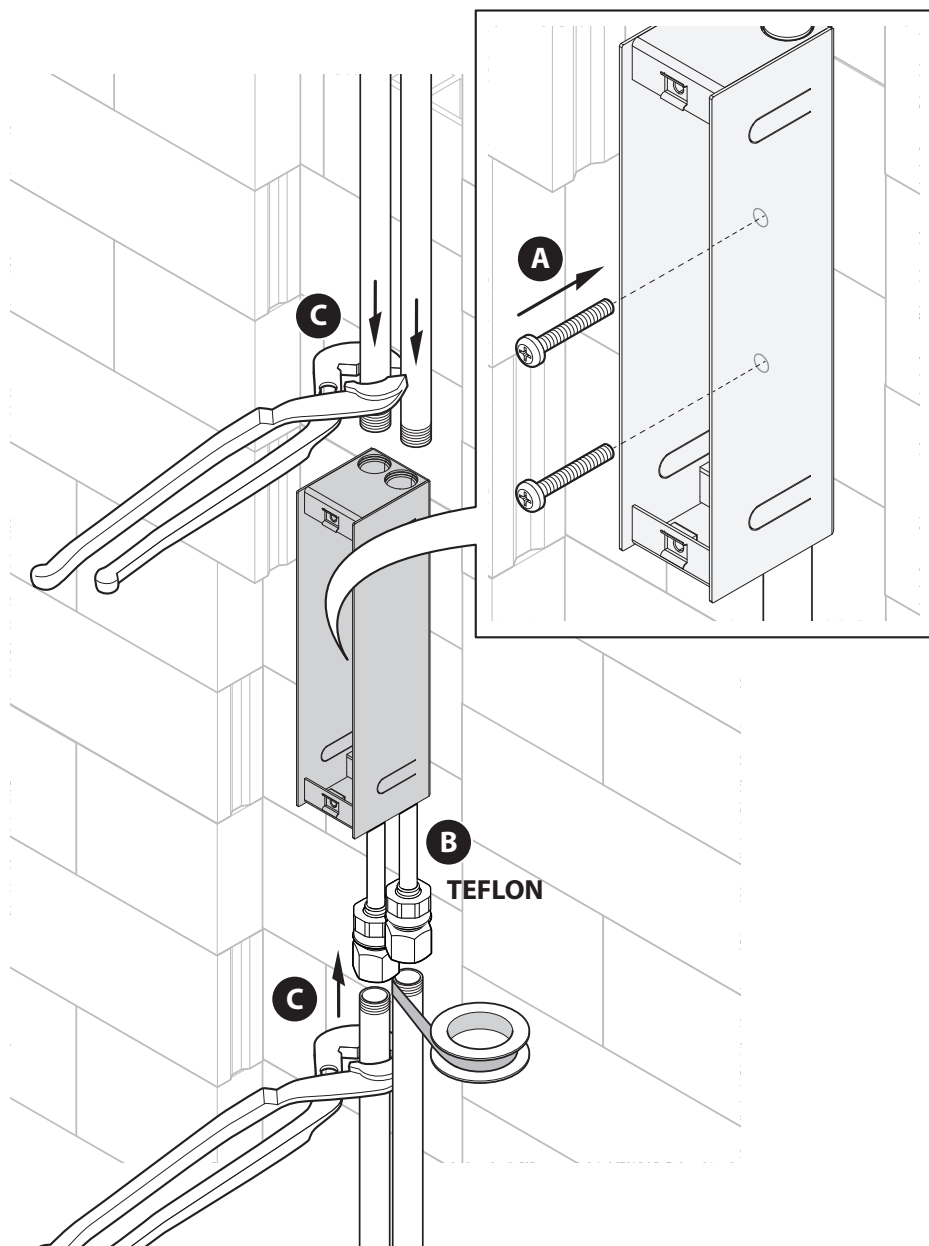

7.

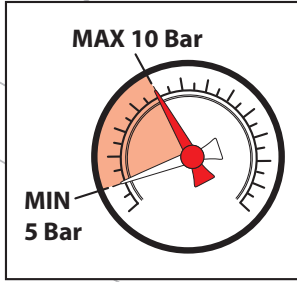

H<sub>2</sub>O

H<sub>2</sub>O

8.



H<sub>2</sub>O

H<sub>2</sub>O

9.

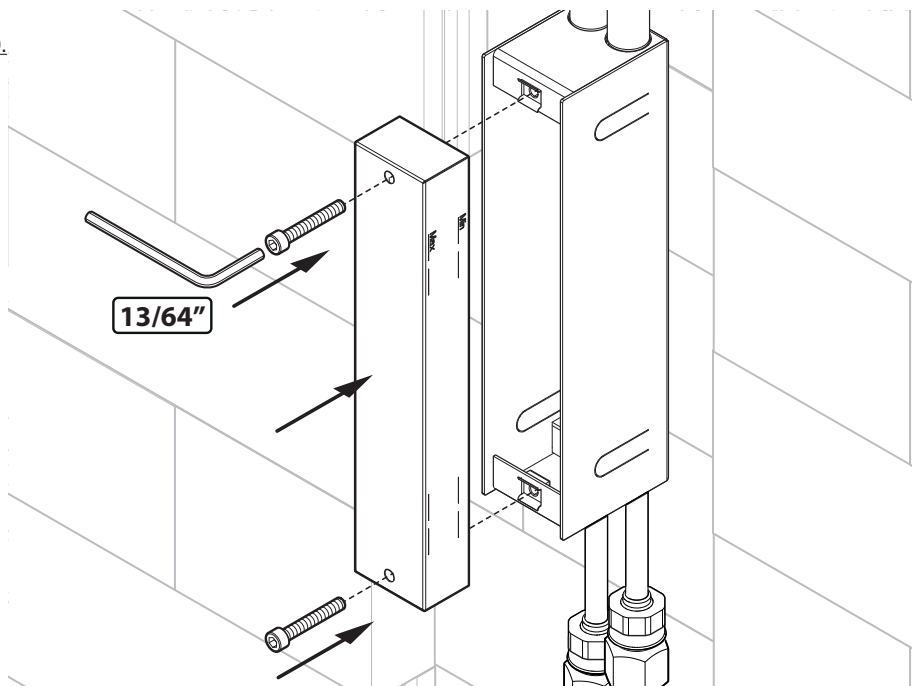

10.

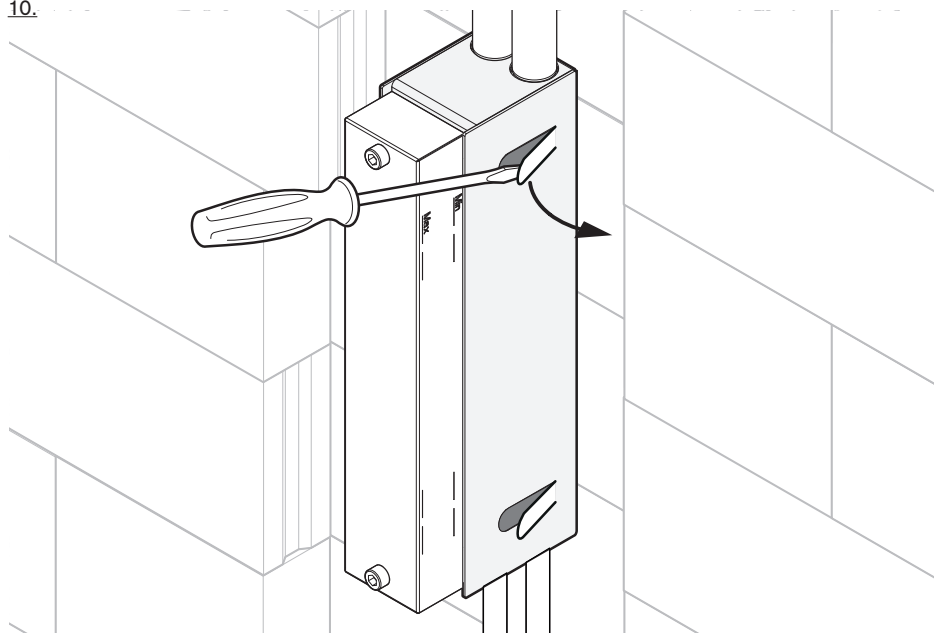

11.

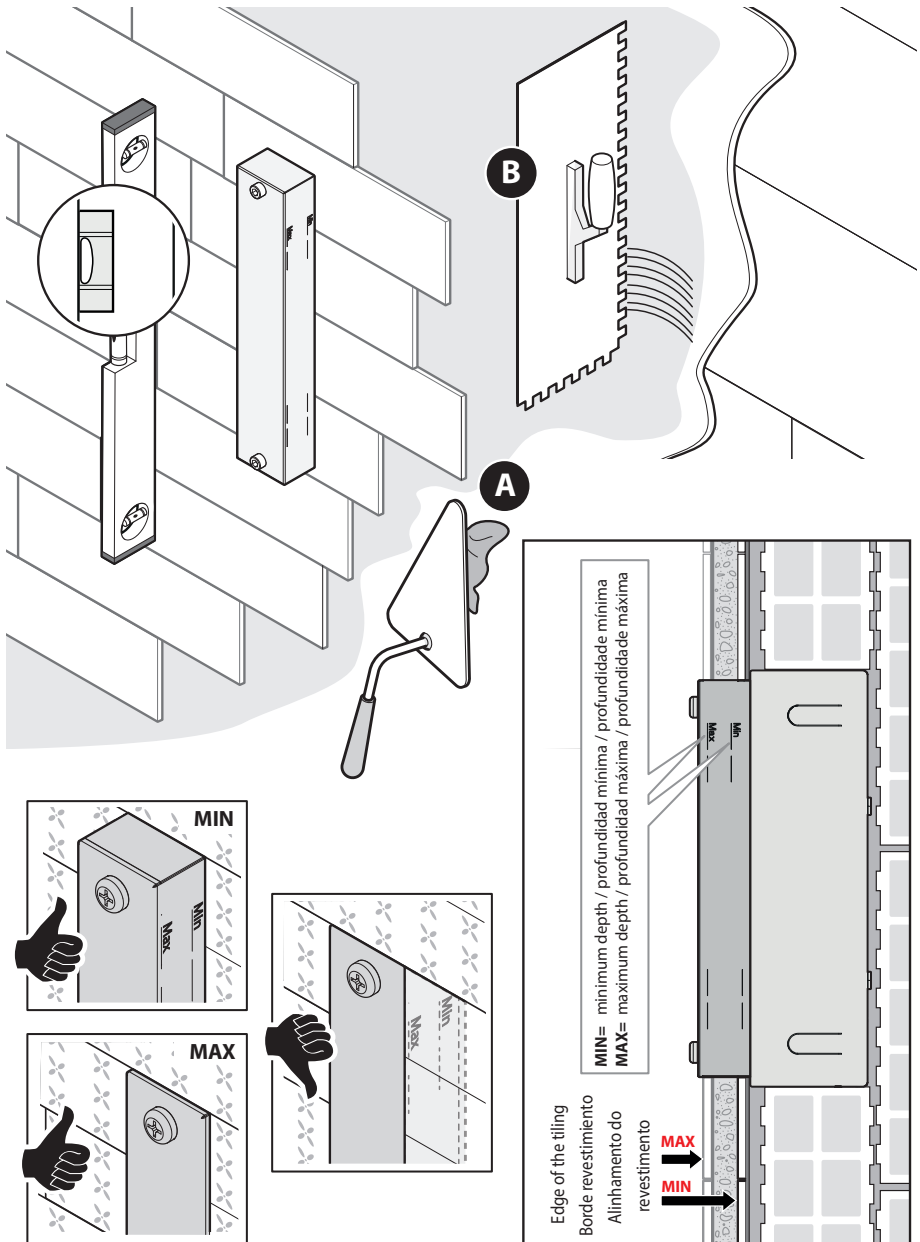

12.



13.

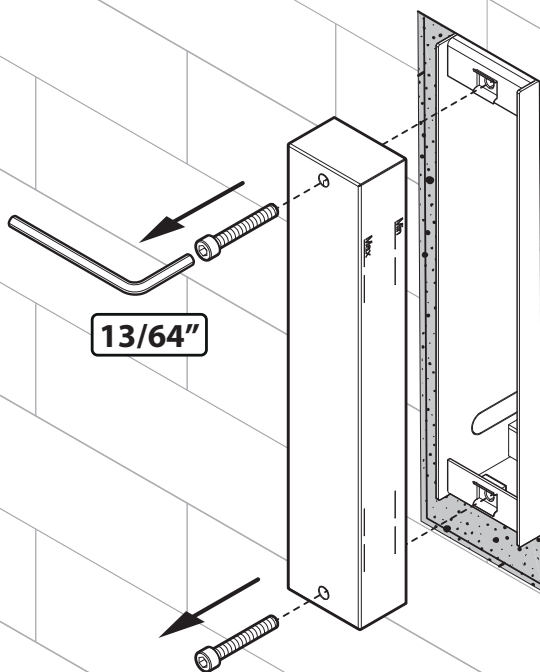

14.

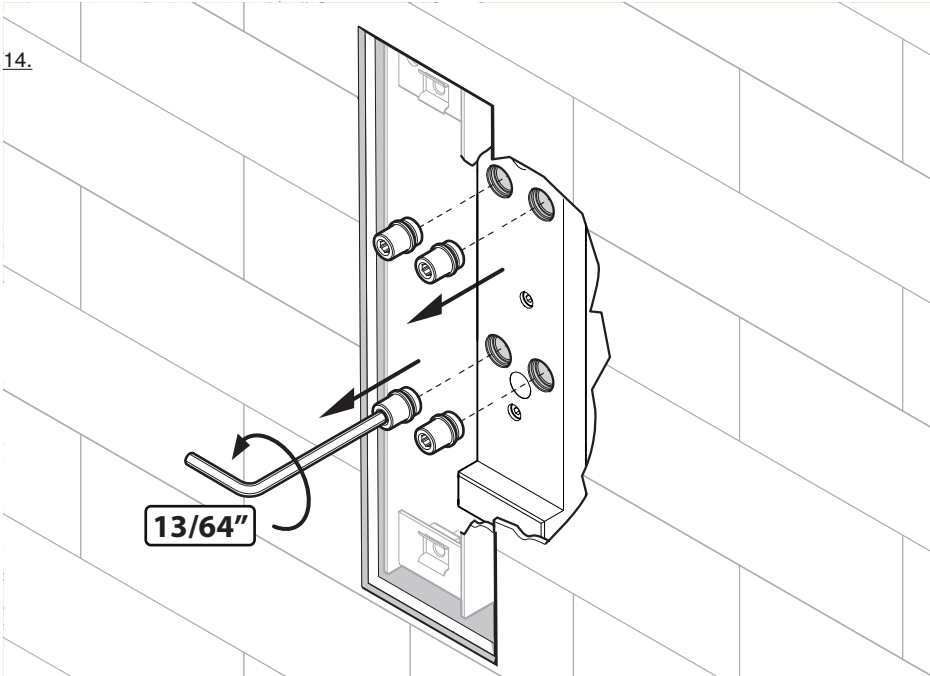

15.

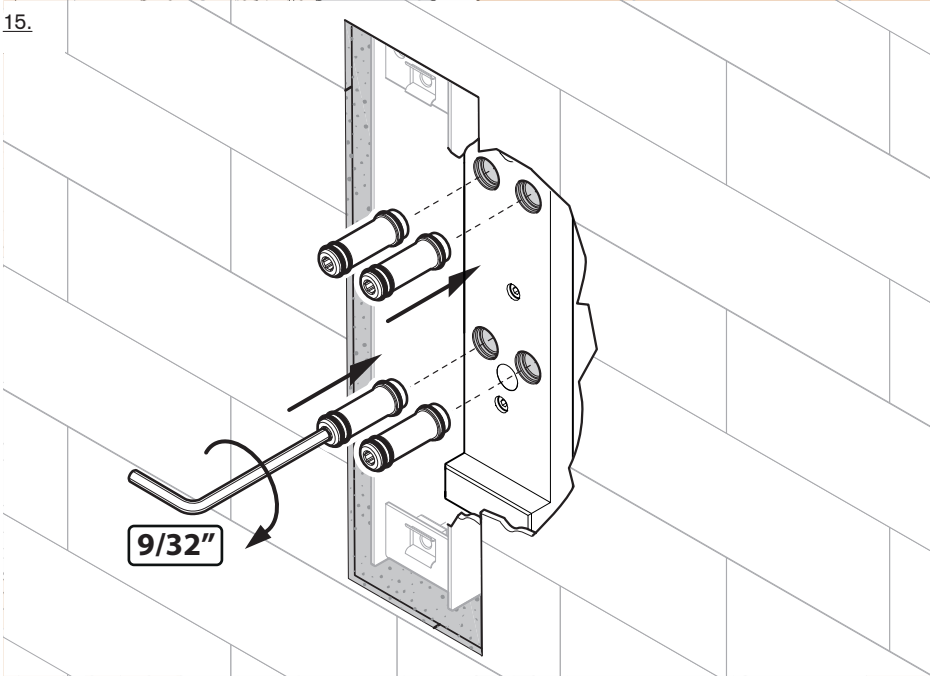



16.

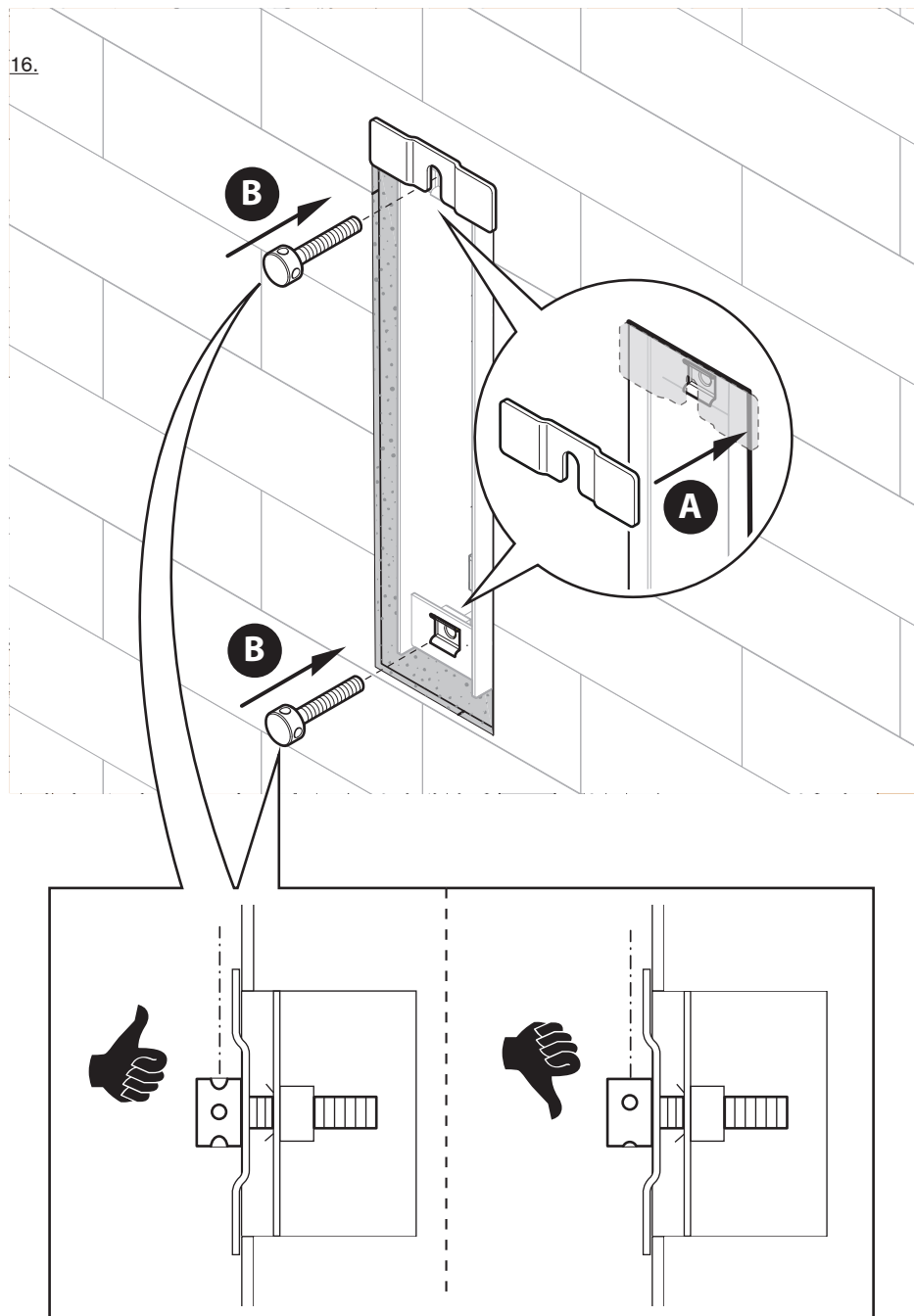

17.

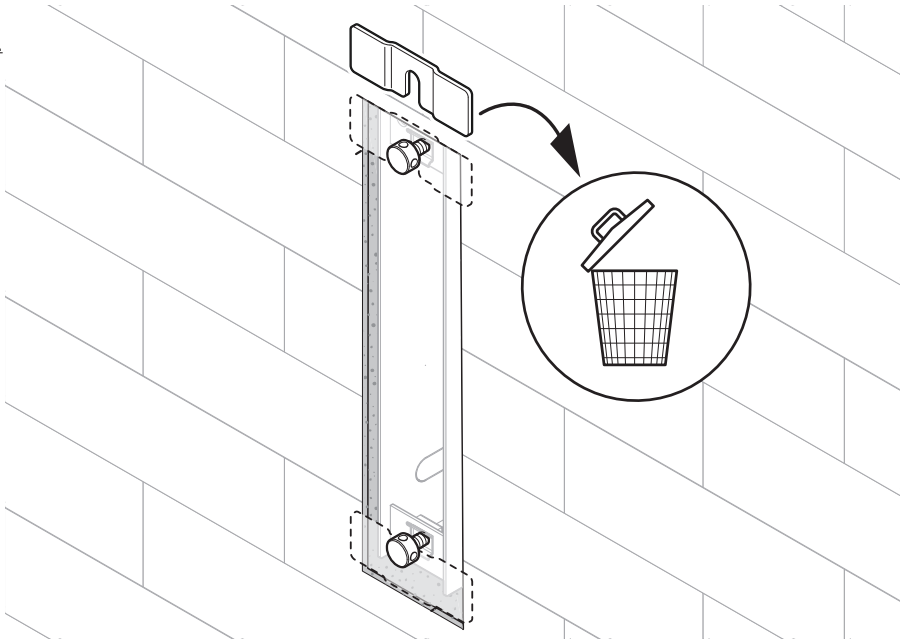

18.

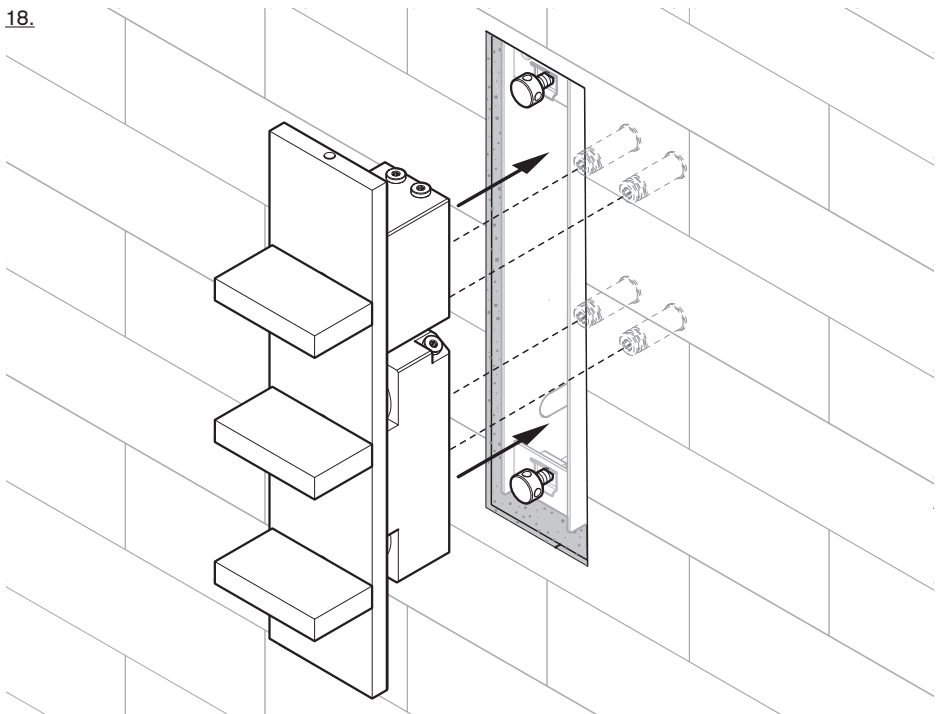

19.

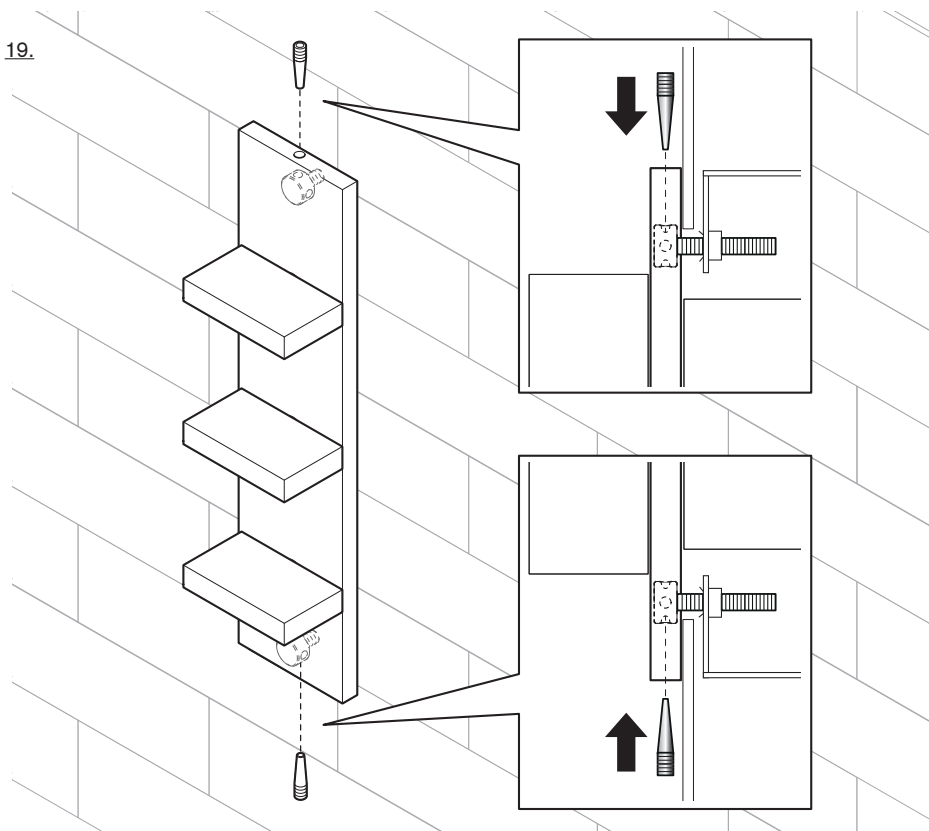

20.

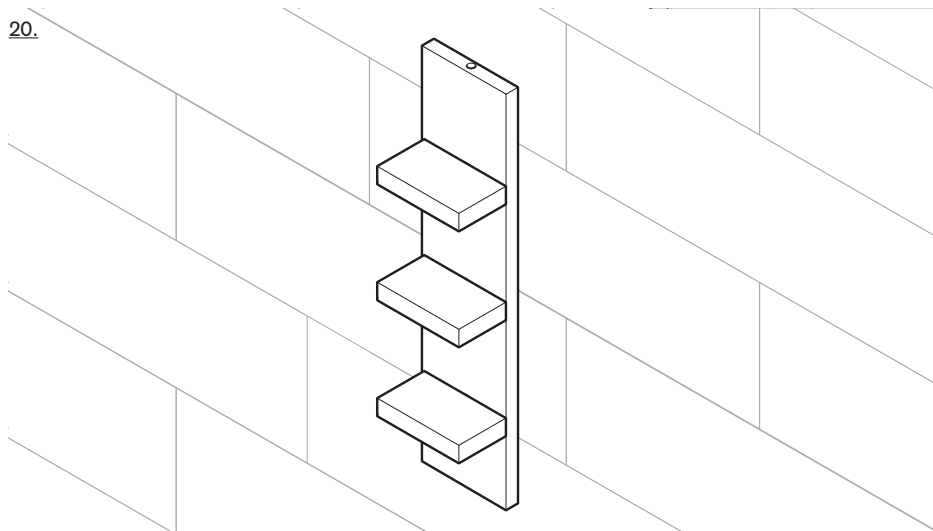

21.

INSTALLING ON PLASTERBOARD  
INSTALLATION SUR PLACOPLÂTRE  
INSTALACIÓN EN CARTÓN-YESO

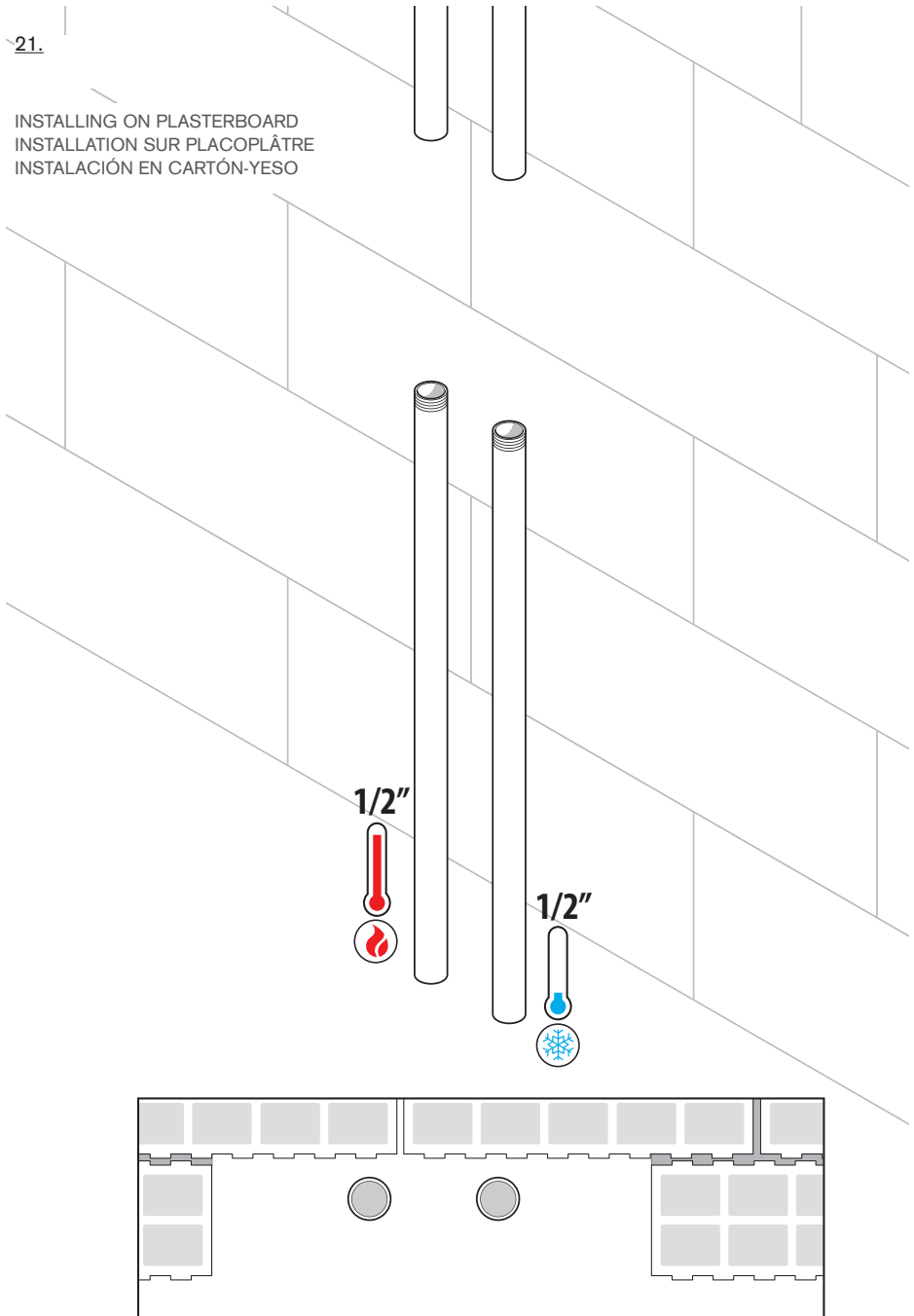

22.

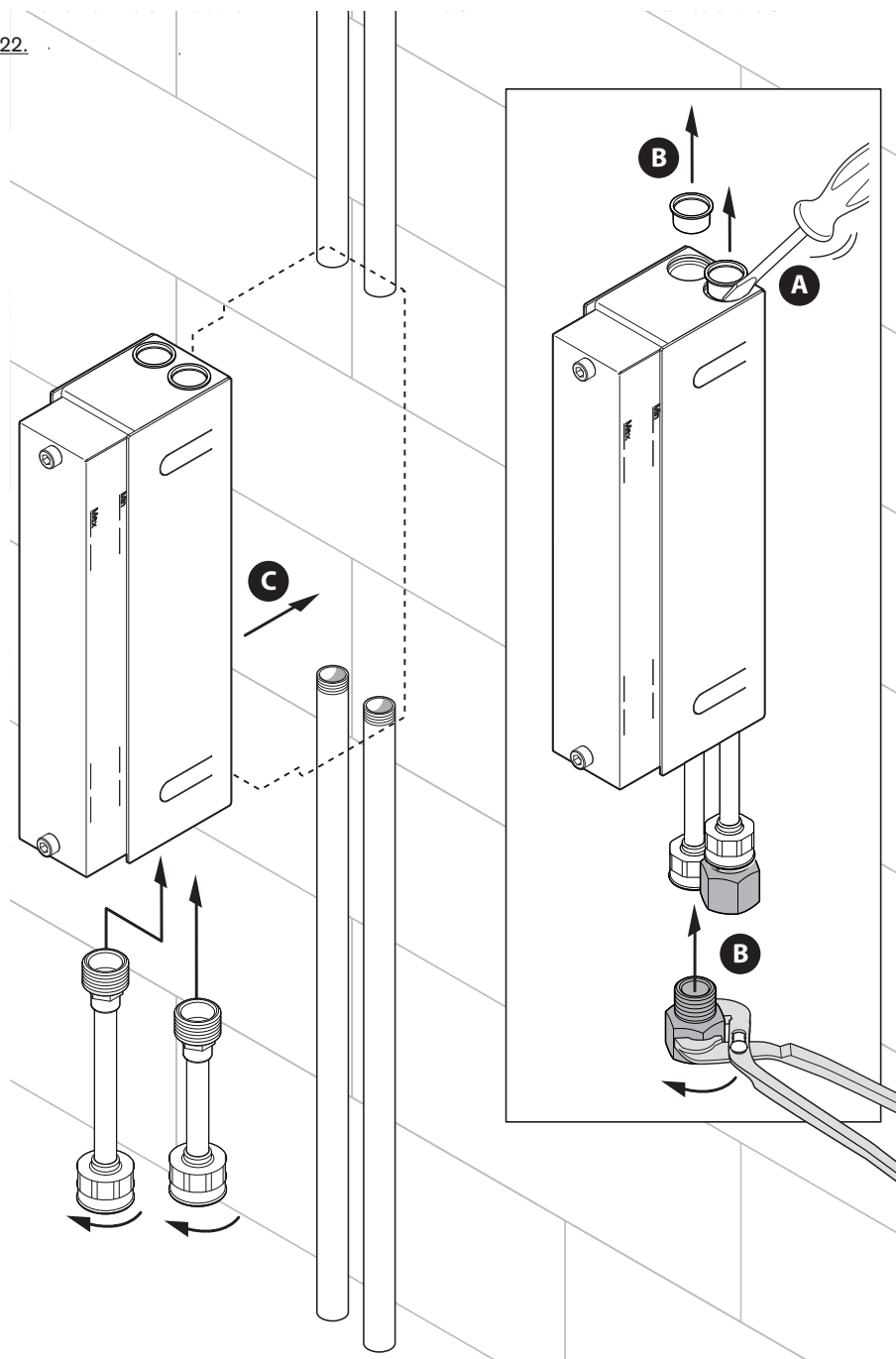

23.

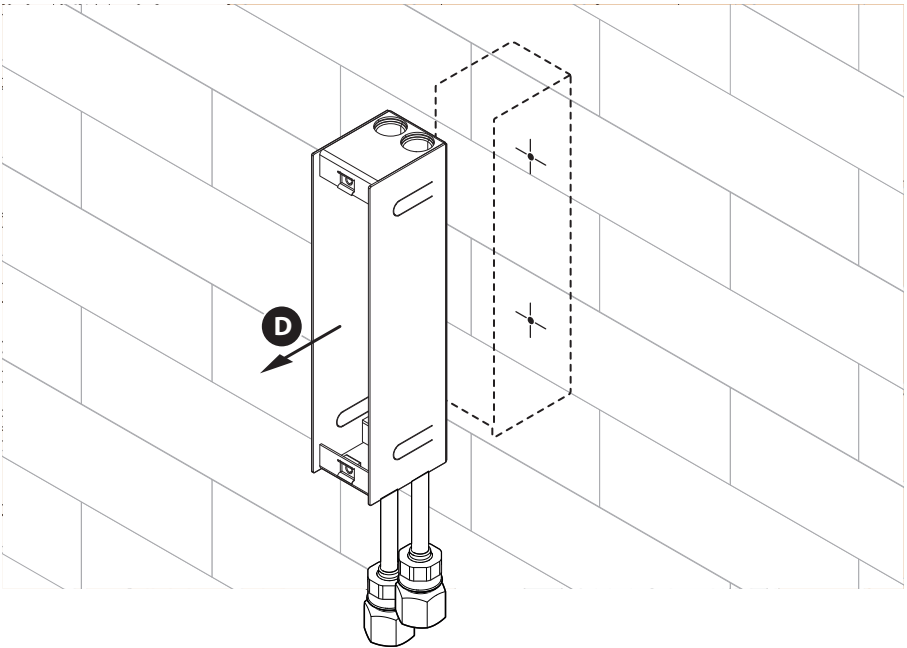
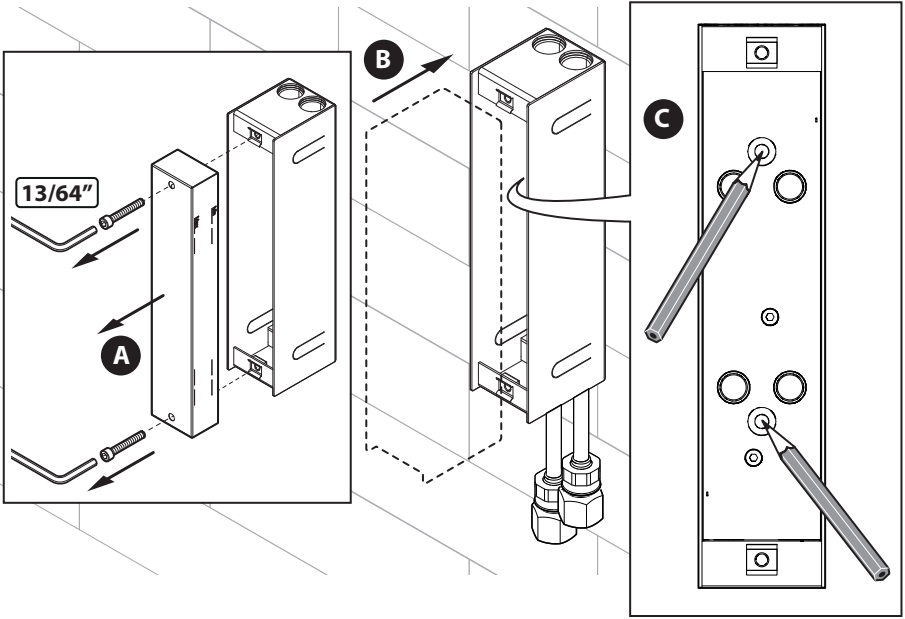

24.

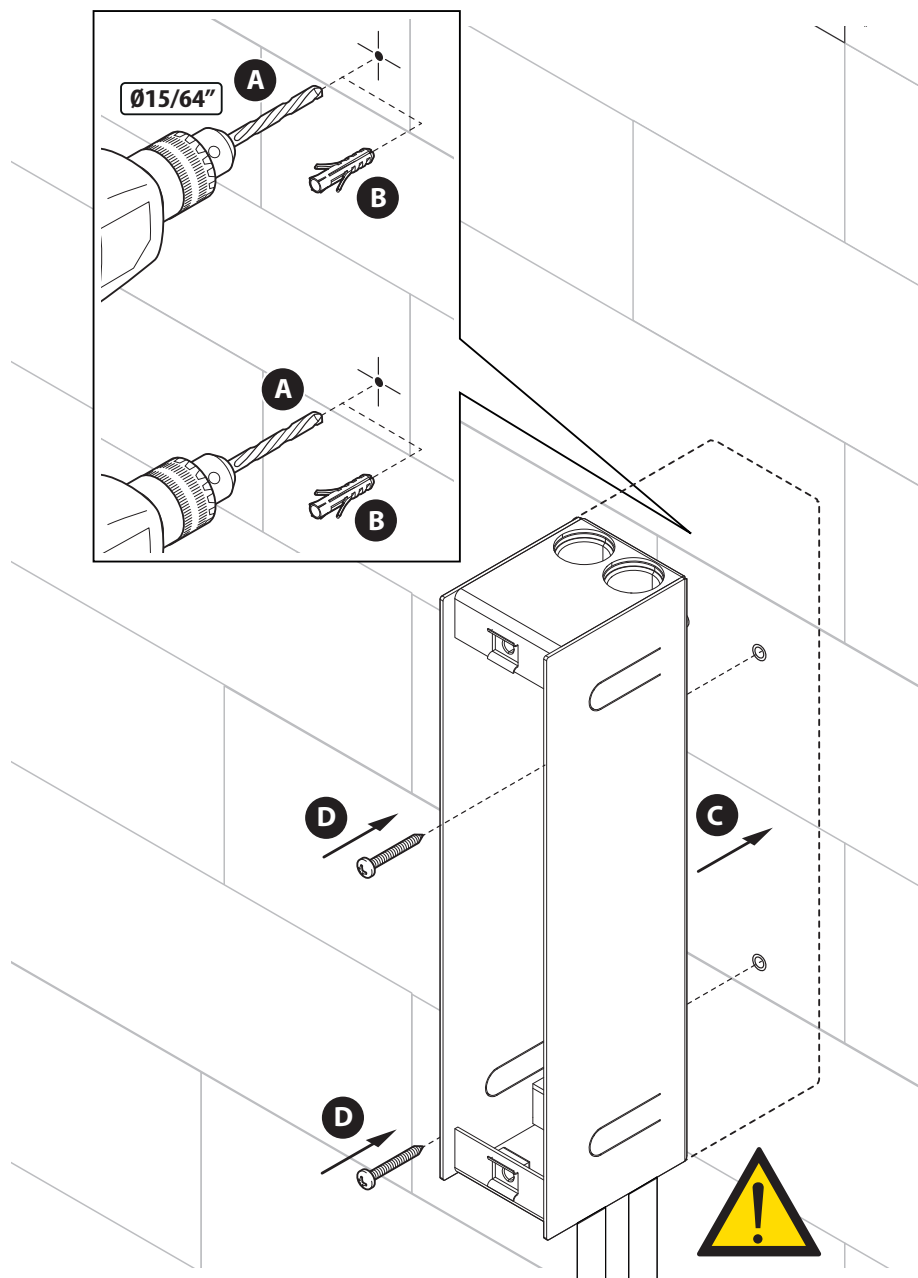

25.

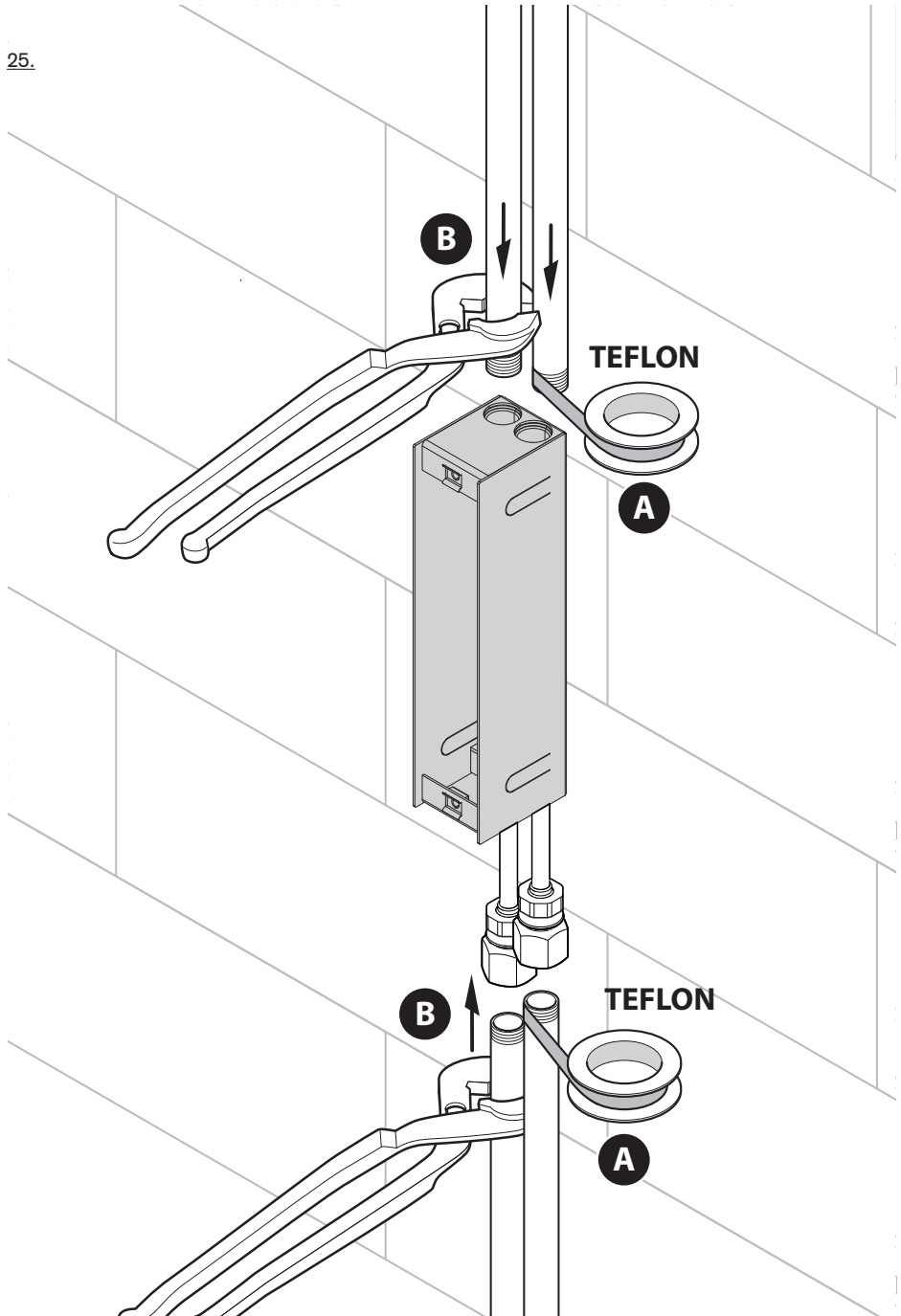



26.

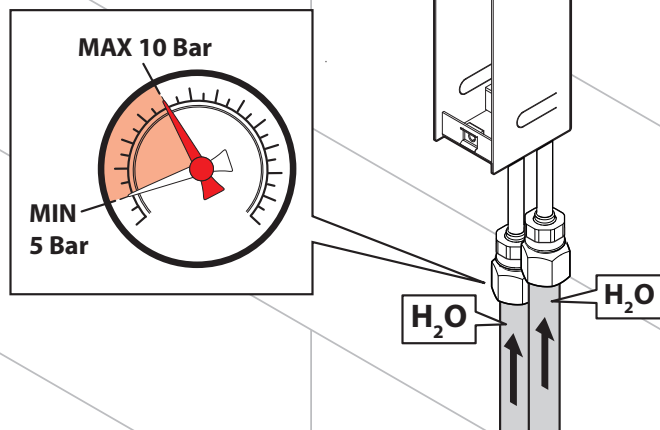

27.

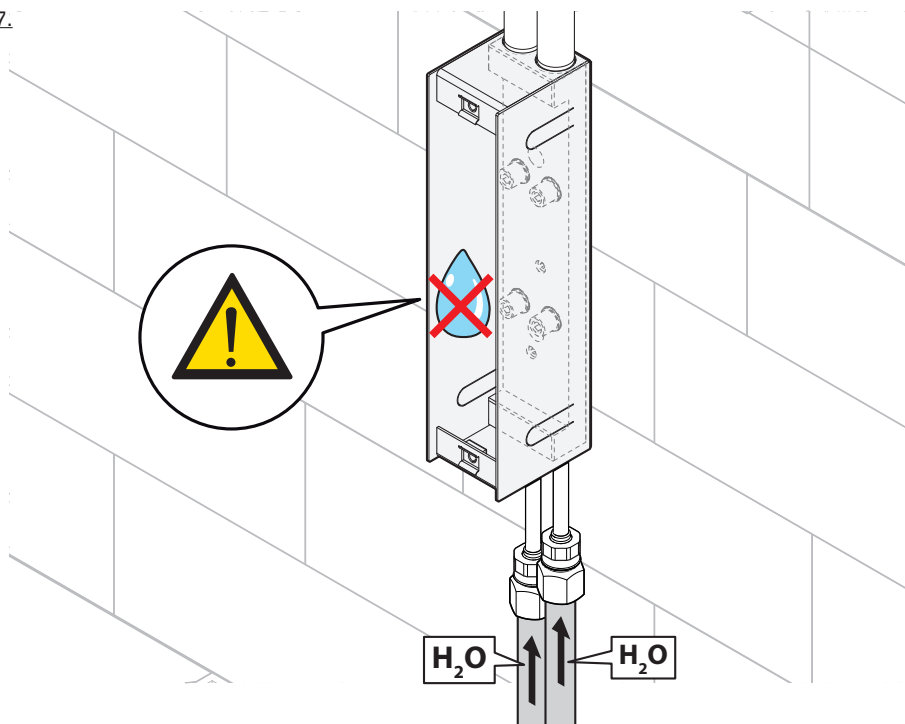

28.

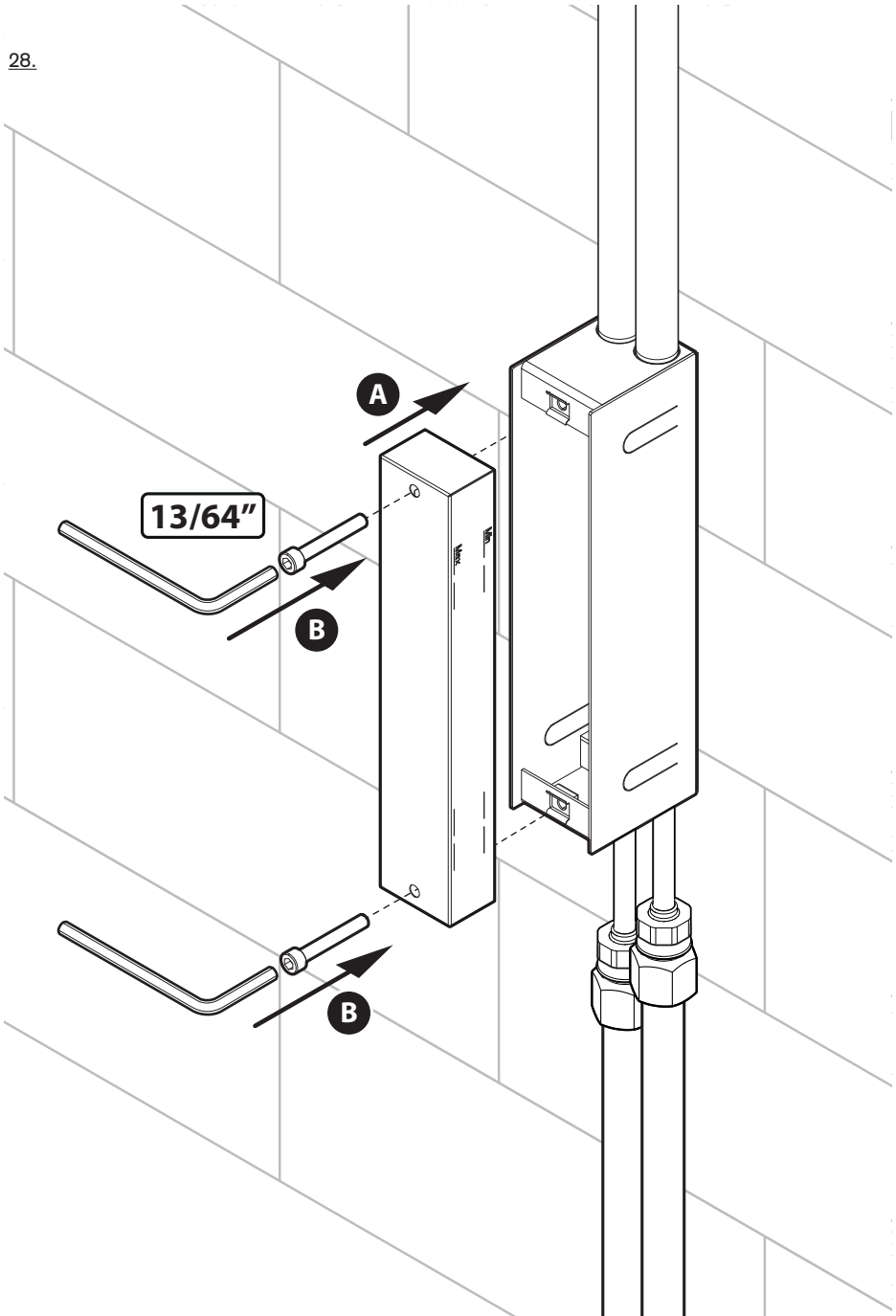

29.

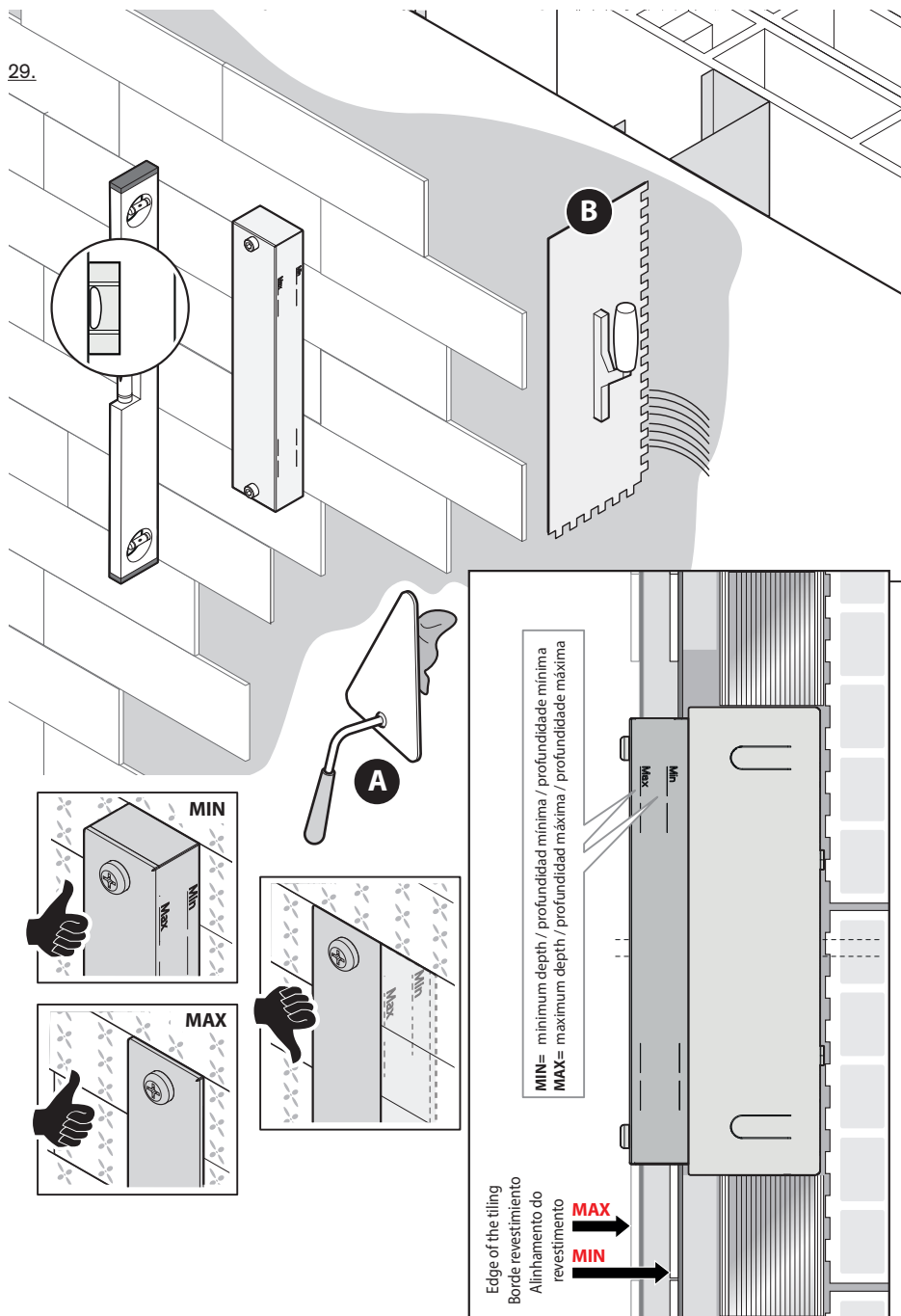

30.

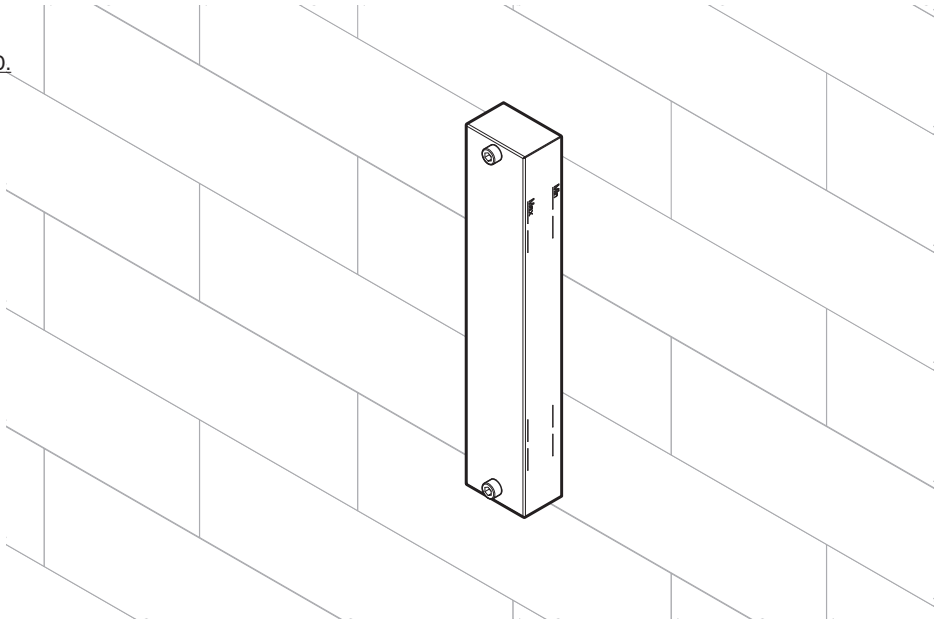

31.

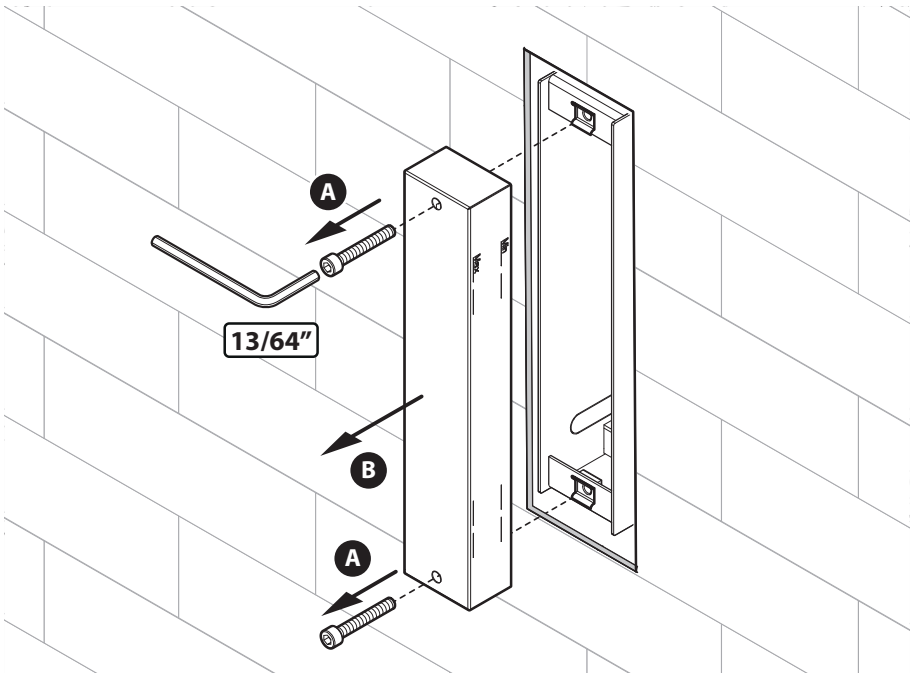

32.

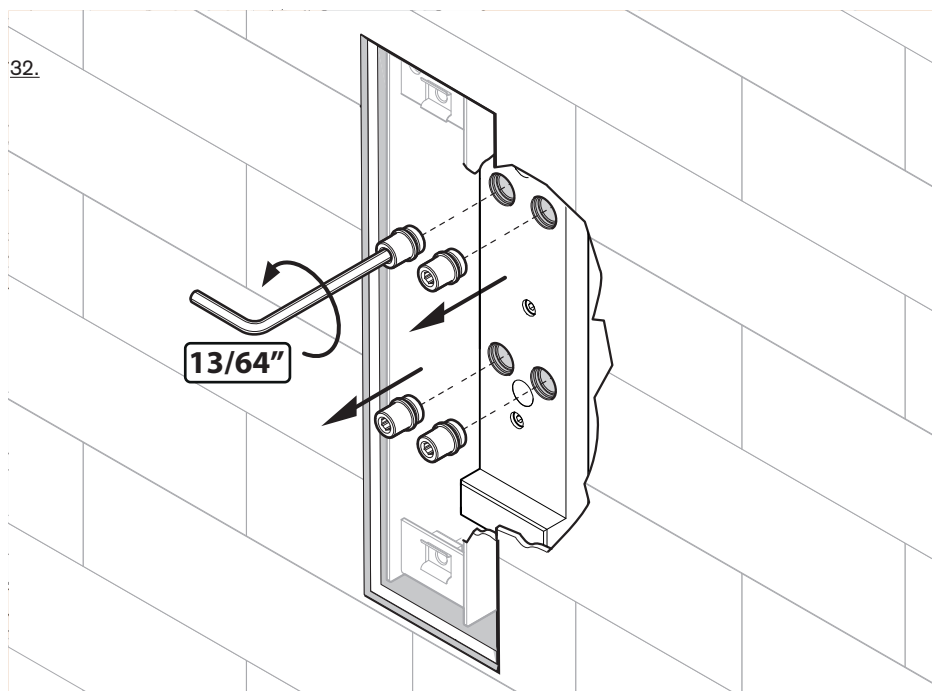

33.

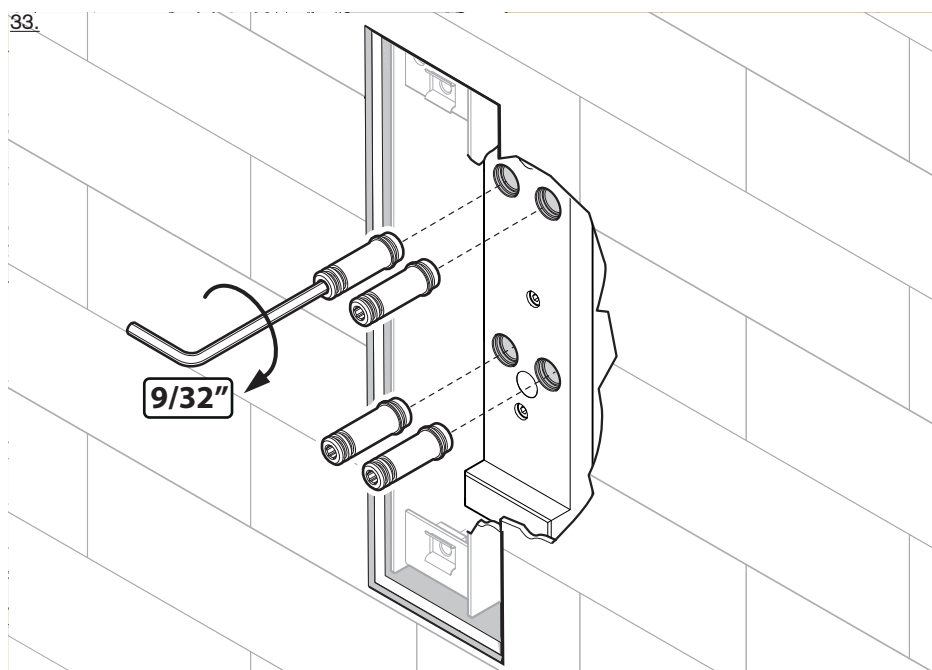

34.

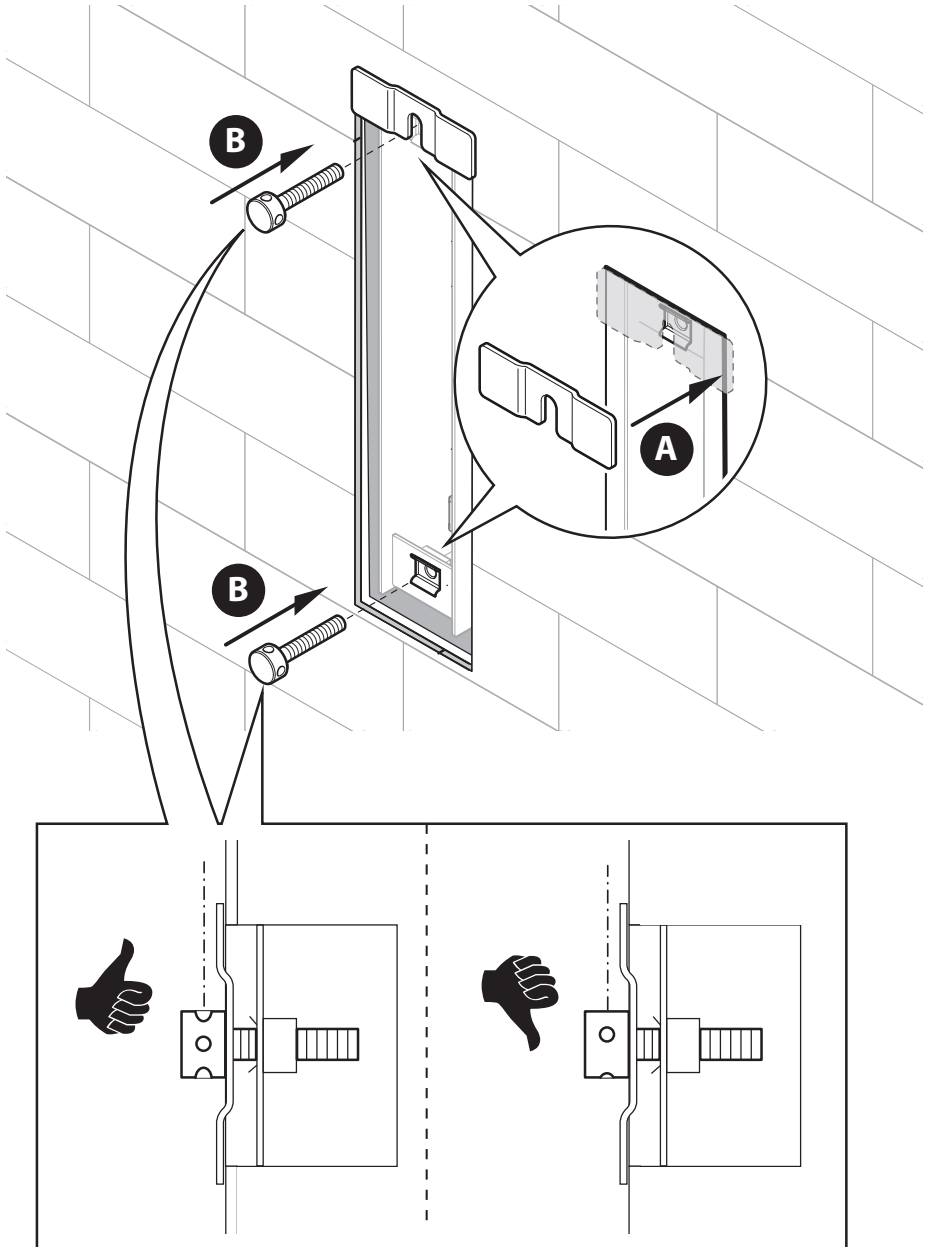

35.

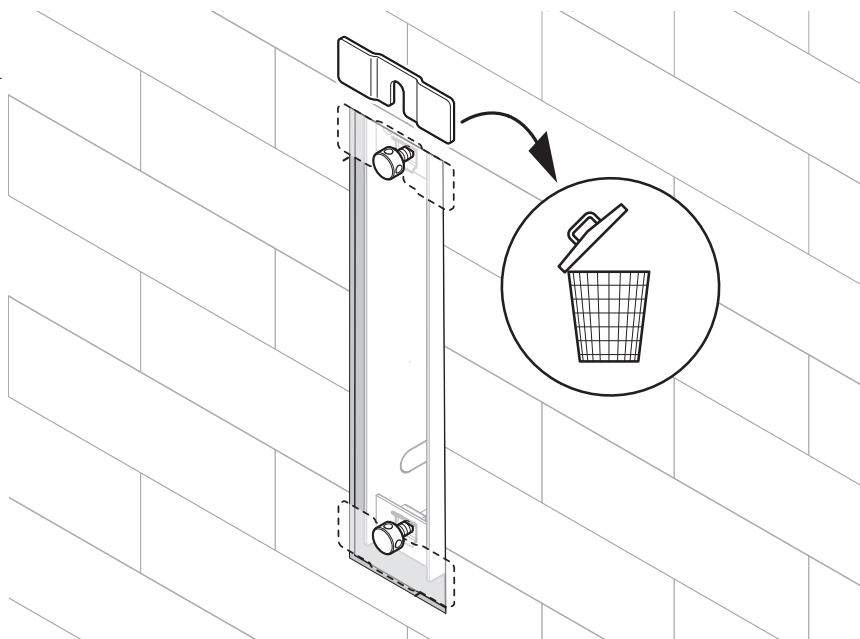

36.

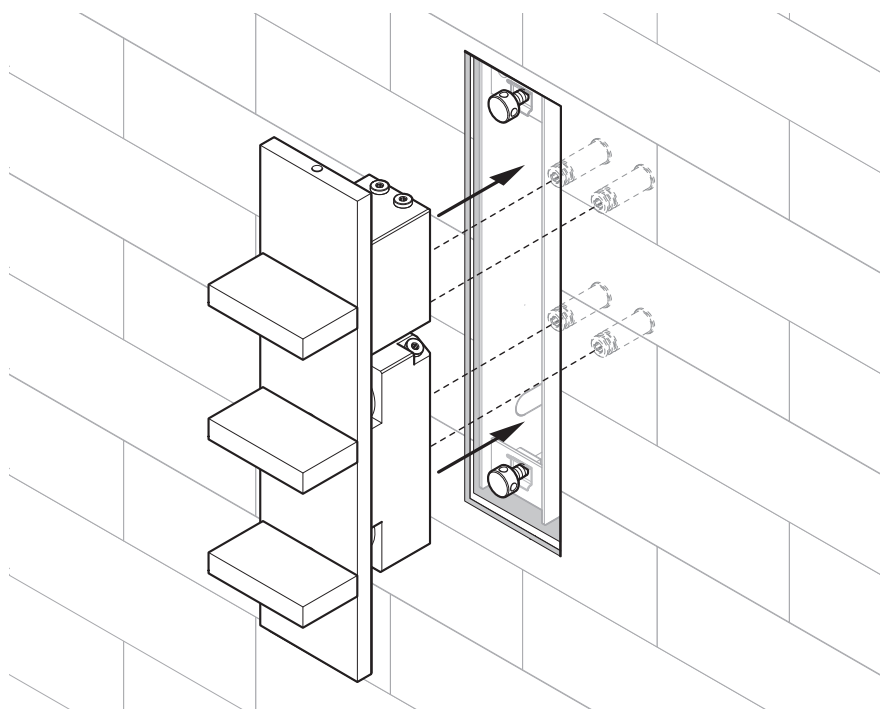

37.

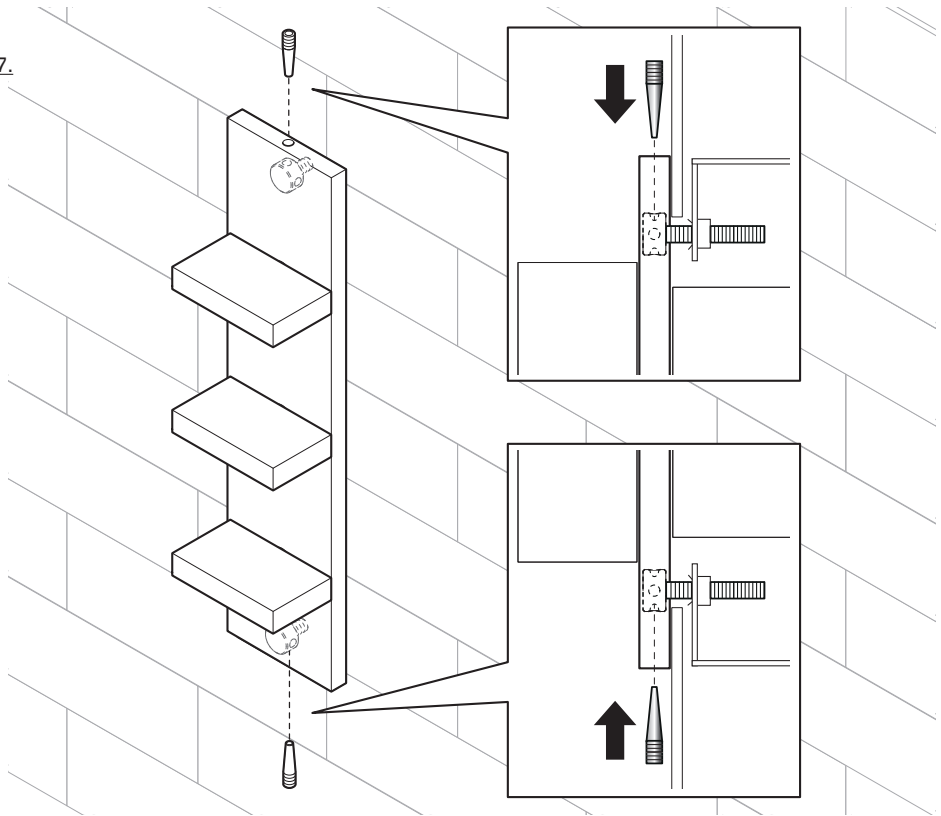

38.

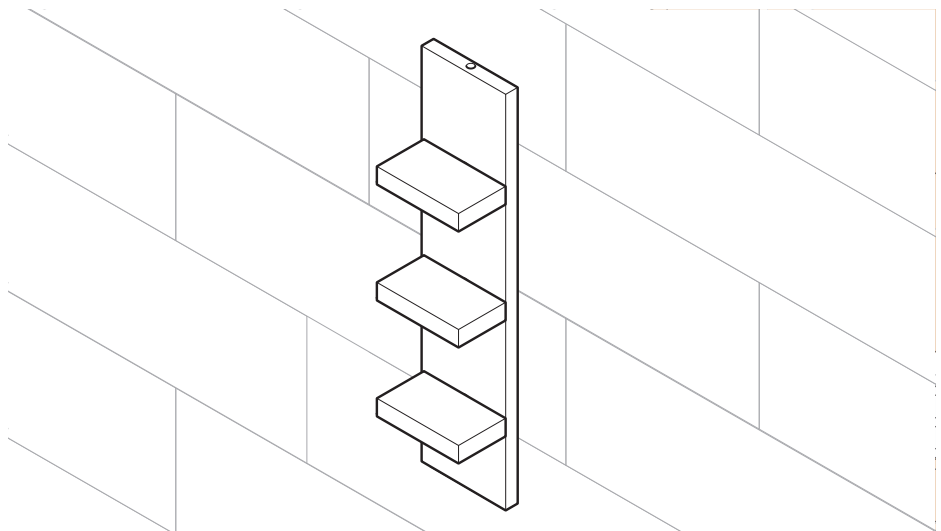



On first use or following prolonged periods of inactivity, do not use the first half-litre of drinking water dispensed. Shut off the plumbing system in the event of a long absence. Check the water-tightness regularly.

ENGLAND.

Lors de la première utilisation ou après une longue période de non utilisation, ne pas consommer le premier demi-litre d'eau potable qui sort du robinet. Fermer l'installation hydraulique en cas d'absence prolongée. Contrôler périodiquement l'étanchéité.

FRANCE.

Durante el primer uso o tras un largo periodo de inactividad, no consumir el primer medio litro de agua potable que salga del grifo. Cerrar la instalación de agua si va a estar ausente durante un largo periodo. Comprobar periódicamente que no haya pérdidas

SPAIN.

**Advice on product care**

To clean the surface use a soap and water solution.

Never use for any reason cleaning solutions containing abrasive substances, chloric acids, ammonia, vinegar, bleach, domestic acids, disinfectants, or anytype of abrasive pad.

**WARNING!** Incorrect cleaning may permanently ruin the surface of the products and in such case the manufacturer may not be held liable for damage.

The Manufacturer reserves the right to modify product and accessories at any time without prior notice. Datas, products and sketches included in this document are just for information and do not bind the producer.

**ENGLAND.****Conseils pour l'entretien du produit**

La poussiere en surface devra être faite en utilisant un savon liquide dilué dans l'eau.

Ne jamais utiliser en aucun cas des détergents liquides contenant des substances abrasives ou à base d'acide, nid'éponges abrasives, vinaigre, ammoniacque, acétone, eau de Javel, acides à usage domestique, désinfectants divers.

**ATTENTION!** L'empli de produits non conseillés peut détériorer irrémédiablement la surface des articles pour lesquels le fabricant ne sera pas responsable.

La société se réserve le droit de modifier ses produits et ses accessoires à tout moment et sans préavis. Informations, produits et croquis reproduits dans ce documents sont de nature informative et ne sont pas contractuels.

**FRANCE.****Consejos para el cuidado del producto**

La limpieza de las superficies se hace utilizando un jabón líquido diluido en agua.

No usar en ningún caso detergentes líquidos que contengan sustancias abrasivas ó a base de ácido clorhídrico, estropajosabrasivos, amoniaco, acetona, lejía, ácidos de uso doméstico, desinfectantes varios.

**ATENCIÓN!** El uso de productos desaconsejados puede danār irremediabilmente las superficies de los elementos, de lo cual el fabricante no se hará responsable en ningún caso.

La sociedad se reserva el derecho de modificar sus productos y accesorios en cualquier momento y sin previo aviso.

**SPAIN.**

Notes

A series of 20 horizontal dotted lines for writing notes.

# ABOUTWATER

114800005000000U Rev.1



# ABOUTWATER



**Fratelli Fantini SpA**

via Buonarroti, 4

28010 Pella (NO) Italia

T +39 0322 918411 r.a.

F +39 0322 969530

[www.aboutwater.it](http://www.aboutwater.it)

[www.fantini.it](http://www.fantini.it)

[fantini@fantini.it](mailto:fantini@fantini.it)