

ABOUTWATER AA/27

Instructions / Instructions de Montage / Instrucciones



ART. 8127U



ART. 8128U

Tools needed / Outils nécessaires / Instrumentos necesarios

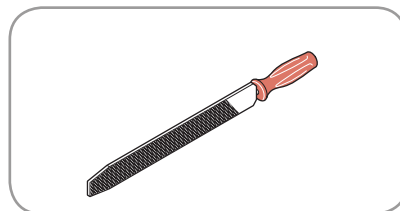
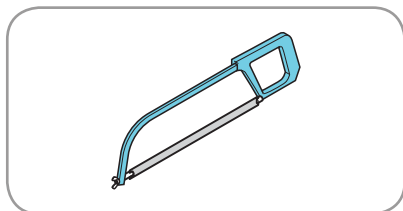
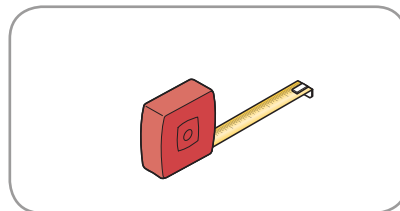
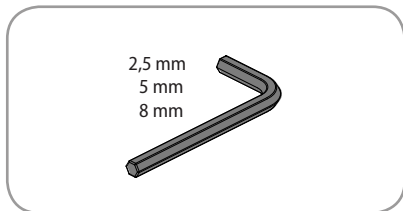
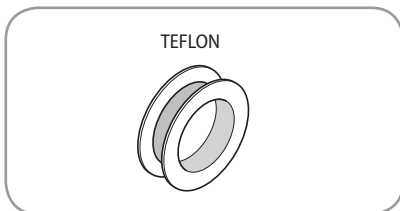
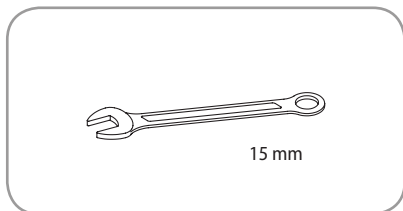

Lorem ipsum

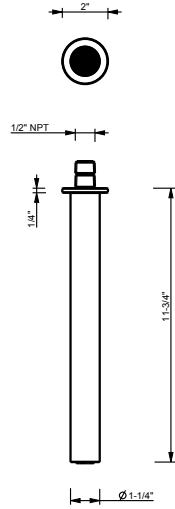

ART. 8127U Rain showerhead
Pomme de douche jet pluie
Rociador lluvia

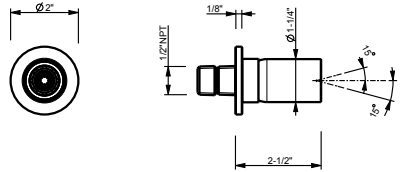

ART. 8128U Lateral body spray
Pomme de douche latérale
Jet lateral

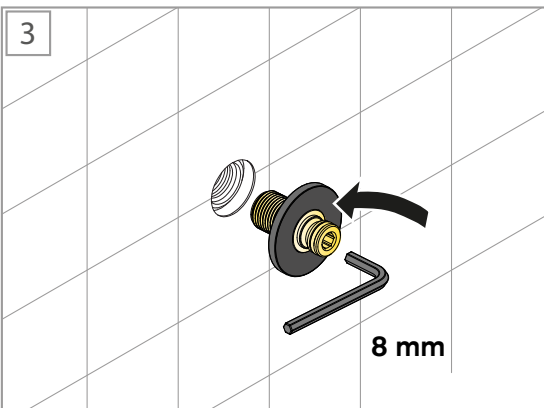
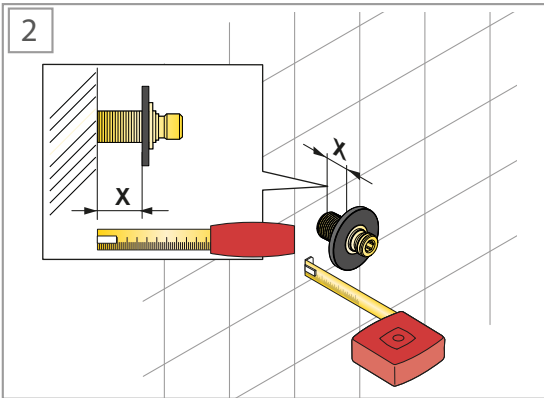
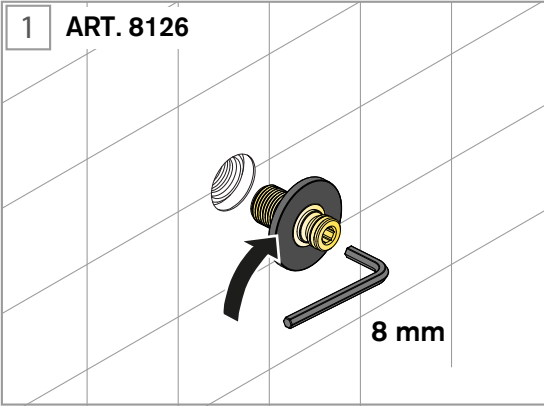

4

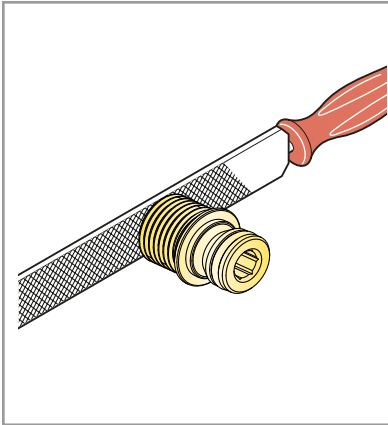
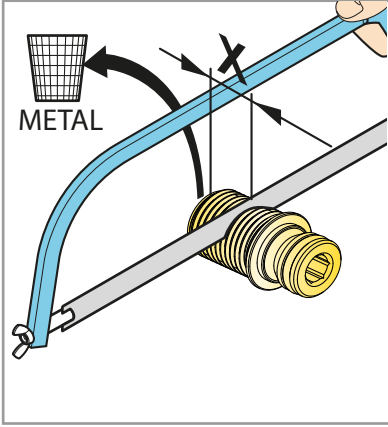

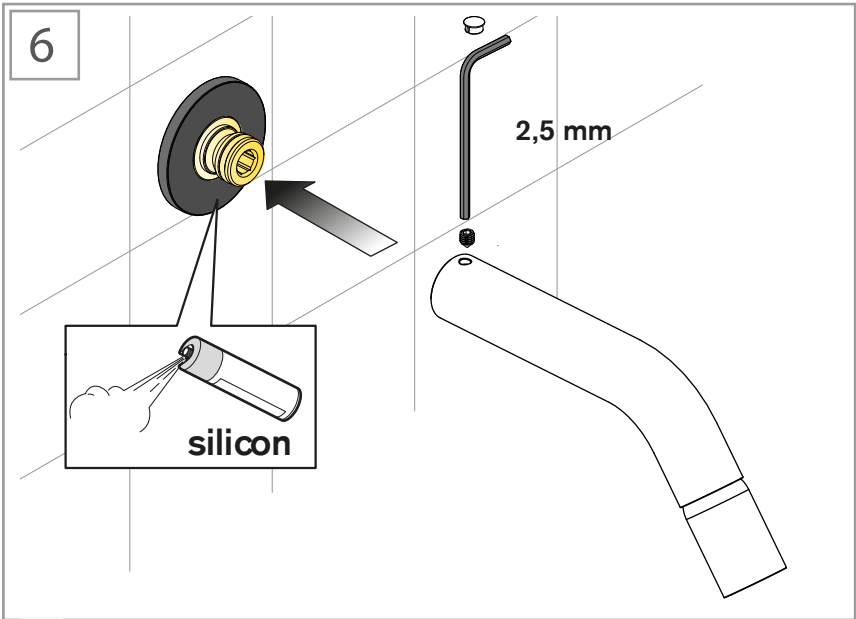
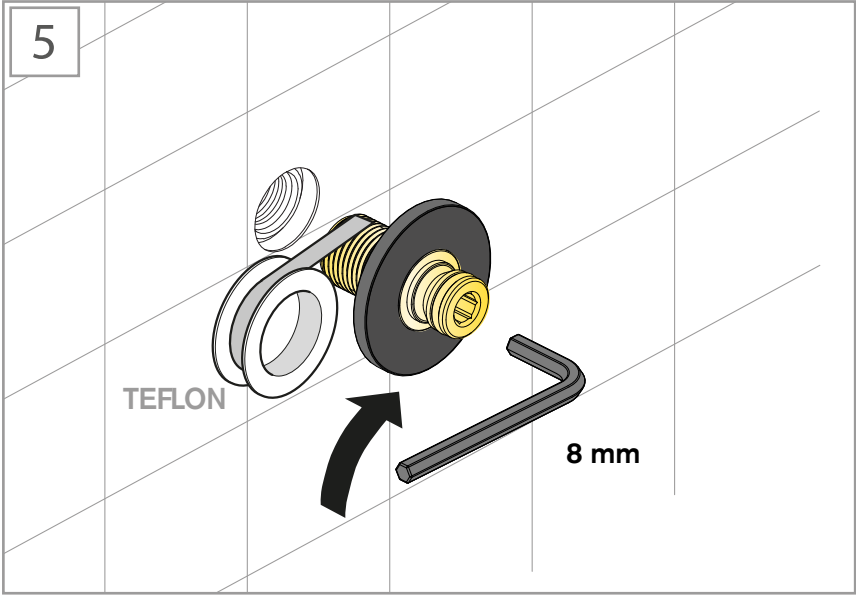

SUBSTITUTE AERATOR - REMPLACEMENT DE L'AÉRATEUR - SUSTITUIR EL AIREADOR

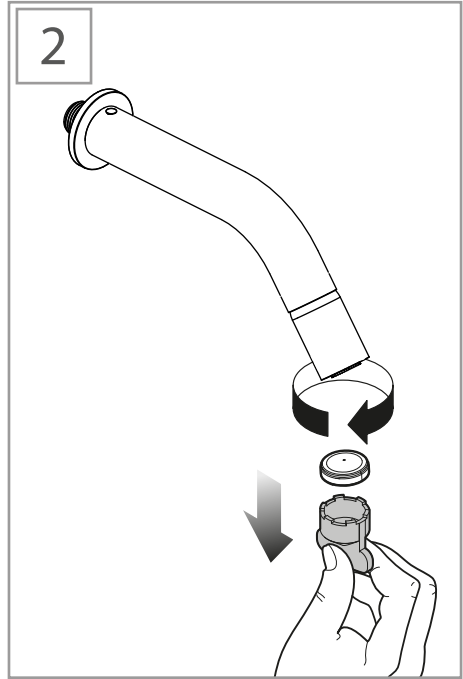
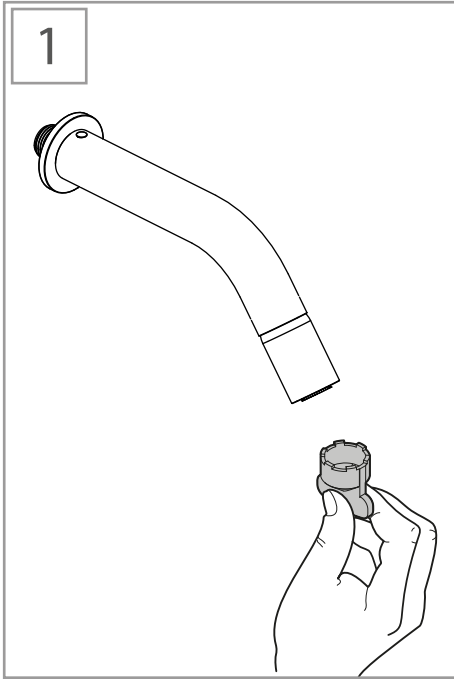

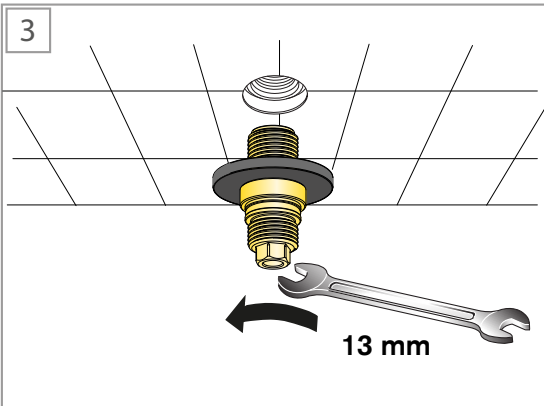
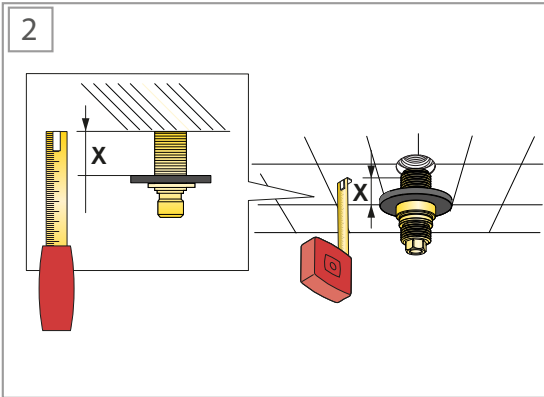
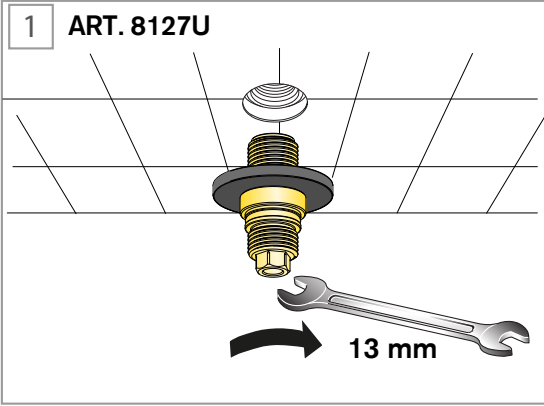

4

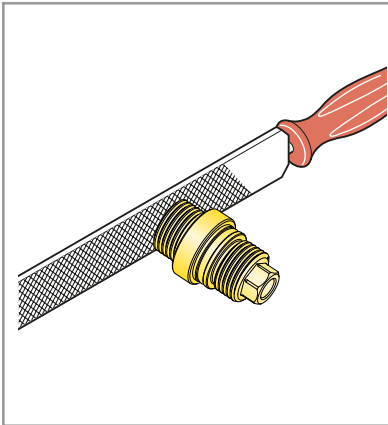
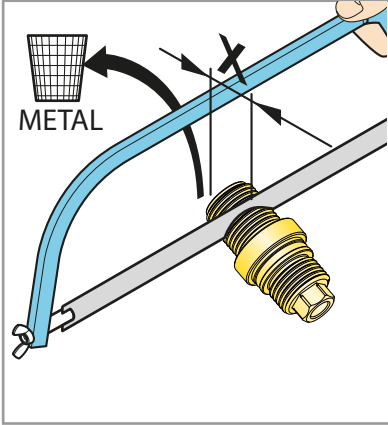

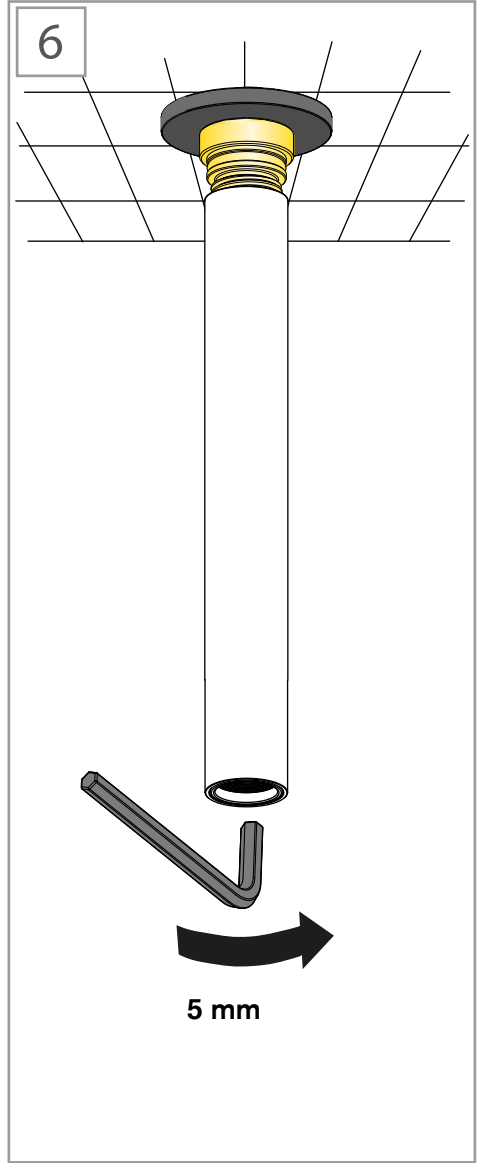
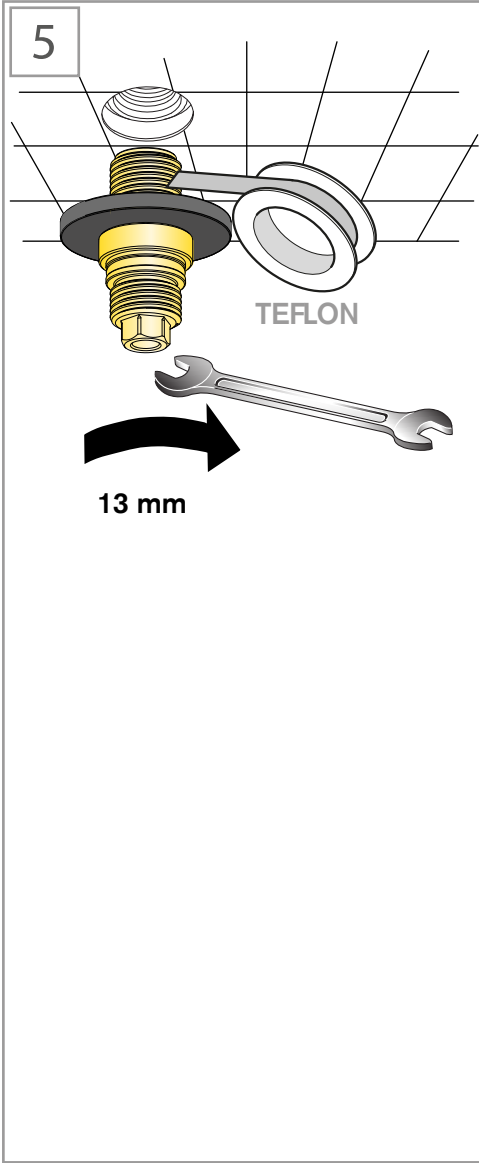

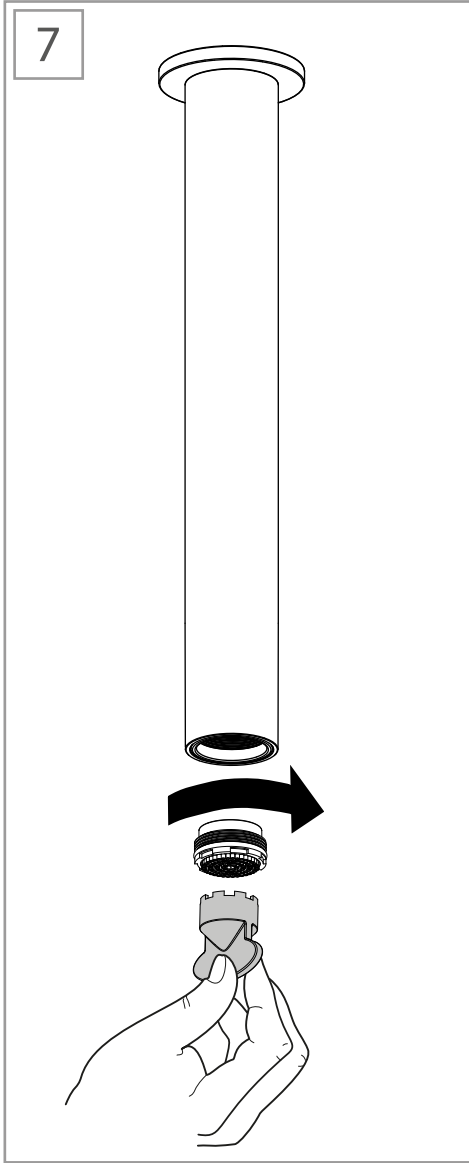

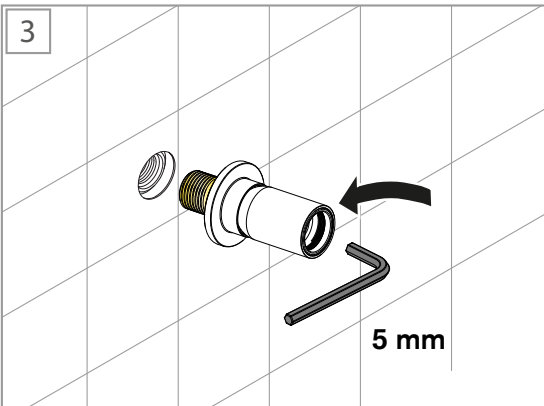
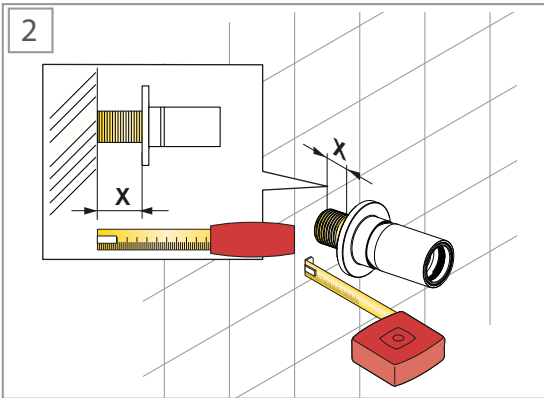
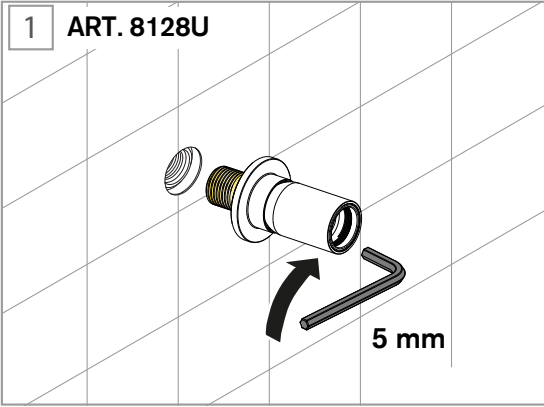

4

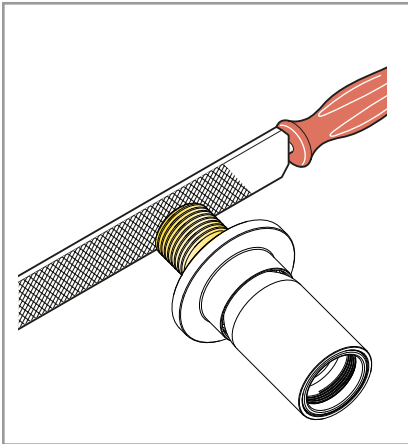
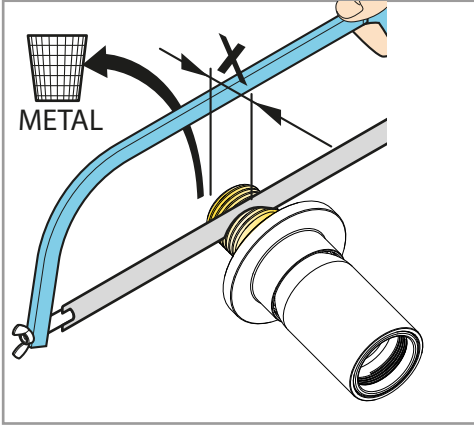

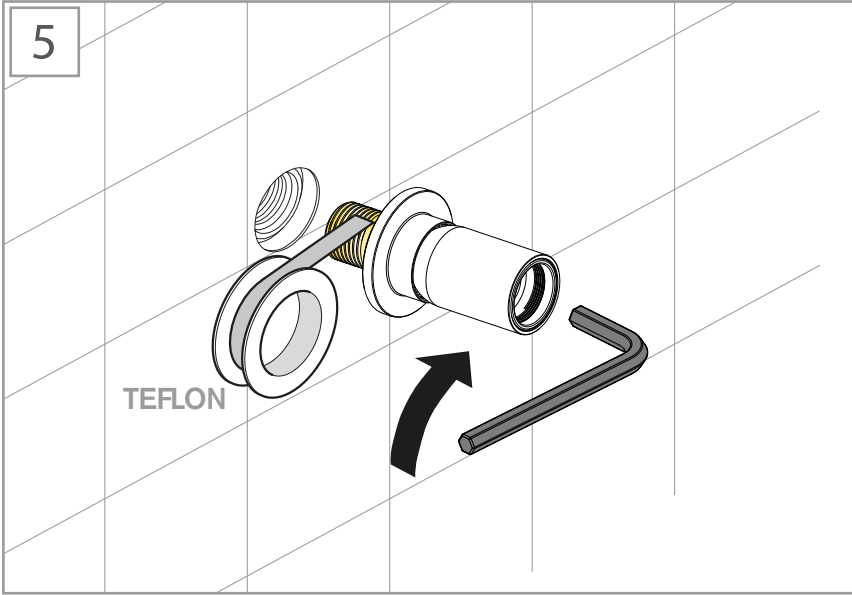

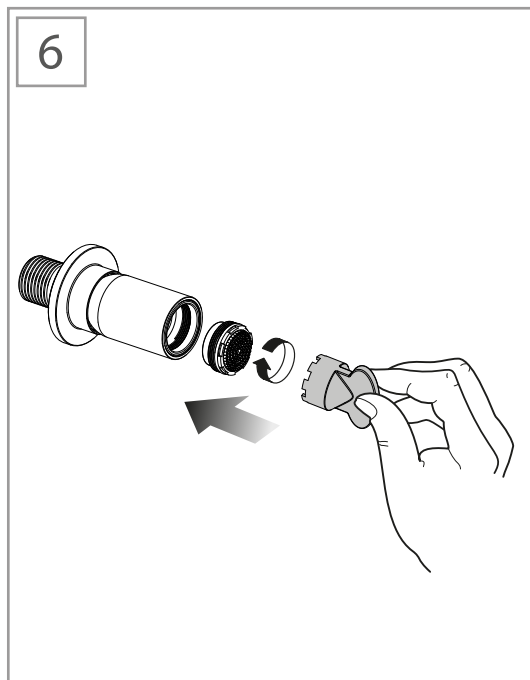

INSTALLAZION - INSTALLATION - INSTALACIÓN

Dati tecnici

Minimum pressure	1 BAR
Maximum pressure	10 BAR
Reccomended working pressure	2-5 BAR
Maximum water temperature	80°
Maximum water temperature reccomended	65°

ENGLAND.

Datos Técnicos

Pression mínima	1 BAR
Pression máxima	10 BAR
Pression de trabajo aconsejada	2-5 BAR
Temperatura máxima	80°
Temperatura máxima aconsejada	65°

SPAIN.

Caractéristiques techniques

Pression minimum	1 BAR
Pression maximum	10 BAR
Pression optimale de service	2-5 BAR
Température maximum	80°
Température maximum optimale	65°

FRANCE.

Advice on product care

To clean the surface use a soap and water solution.

Never use for any reason cleaning solutions containing abrasive substances, chloric acids, ammonia, vinegar, bleach, domestic acids, disinfectants, or any type of abrasive pad.

WARNING! Incorrect cleaning may permanently ruin the surface of the products and in such case the manufacturer may not be held liable for damage.

The Manufacturer reserves the right to modify product and accessories at any time without prior notice. Datas, products and sketches included in this document are just for information and do not bind the producer.

ENGLAND.

Conseils pour l'entretien du produit

La poussière en surface devra être faite en utilisant un savon liquide dilué dans l'eau.

Ne jamais utiliser en aucun cas des détergents liquides contenant des substances abrasives ou à base d'acide, nid'éponges abrasives, vinaigre, ammoniacque, acétone, eau de Javel, acides à usage domestique, désinfectants divers.

ATTENTION! L'emploi de produits non conseillés peut détériorer irrémédiablement la surface des articles pour lesquels le fabricant ne sera pas responsable.

La société se réserve le droit de modifier ses produits et ses accessoires à tout moment et sans préavis.

Informations, produits et croquis reproduits dans ce documents sont de nature informative et ne sont pas contractuels.

FRANCE.

Consejos para el cuidado del producto

La limpieza de las superficies se hace utilizando un jabón líquido diluido en agua.

No usar en ningún caso detergentes líquidos que contengan sustancias abrasivas ó a base de ácido clorhídrico, estropajos abrasivos, amoníaco, acetona, lejía, ácidos de uso doméstico, desinfectantes varios.

ATENCIÓN! El uso de productos desaconsejados puede danar irremediabilmente las superficies de los elementos, de lo cual el fabricante no se hará responsable en ningún caso.

La sociedad se reserva el derecho de modificar sus productos y accesorios en cualquier momento y sin previo aviso.

SPAIN.

ABOUTWATER

11810003000000 Rev.0



ABOUTWATER

Boffi FANTINI

Fratelli Fantini SpA
via Buonarroto, 4
28010 Pella (NO) Italia
T +39 0322 918411 r.a.
F +39 0322 969530
www.aboutwater.it
www.fantini.it
fantini@fantini.it