

ABOUTWATER 8059U-8053U

Instructions / Instrucciones

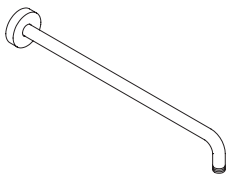

ART. 8059U

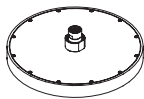

ART. 8053U

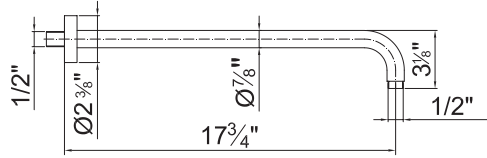
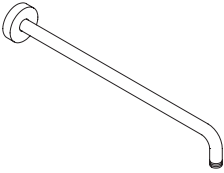

ART. 8059U Shower arm / Brazo de la ducha

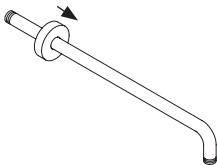

1.

- Screw the flange to the arm
- Atornillar la brida al brazo

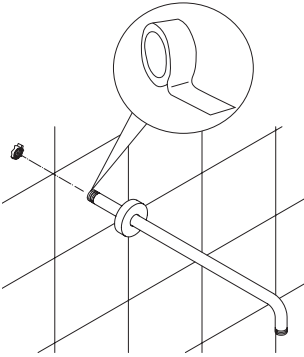

2.

- Place some Teflon on the threaded joint of the arm
- Mettre du téflon sur l'embout fileté du bras
- Colocar cinta de teflon sobre la rosca del brazo

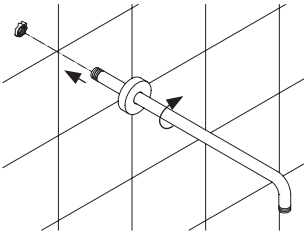

3.

- Screw the arm to the tube installed in the wall
- Atornillar el brazo al tubo instalado en el muro

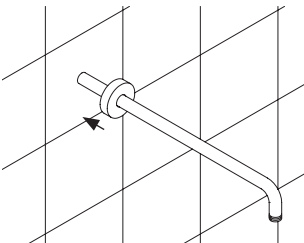

4.

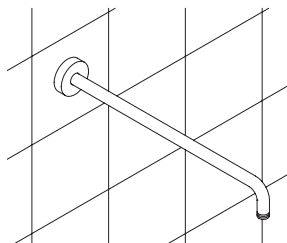

5.

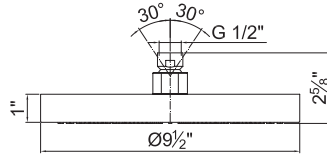
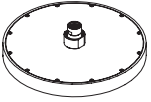

ART. 8053U Shower head / Ducha

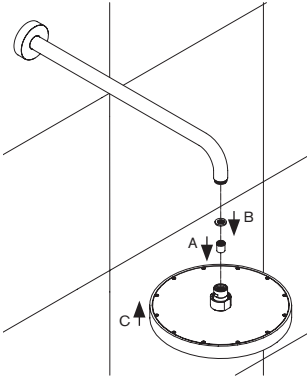

1.

- Showerhead with non-return valve and water supply of 12l/min. If you would like more water, replace this valve with the unrestricted non-return valve provided.
- La ducha està provista de una vàlvula de retenció amb limitador de caudal de 12 l/min. Si se desea un mayor caudal, reemplaçar dicha vàlvula con la vàlvula de retenció sin limitador de caudal, també provista en la confecció.

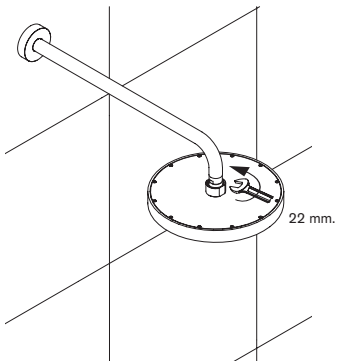

2.

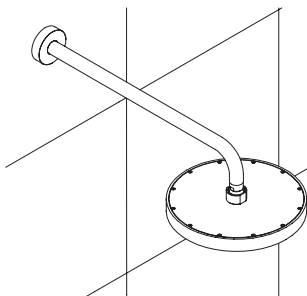

3.

Maintenance / Mantenimiento

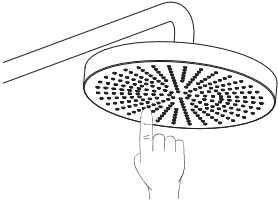

1.

- It is advisable to periodically clean the showerhead nozzles as shown in the illustration.
- Limpiar periódicamente los orificios de la ducha como se muestra en la figura

Dati tecnici

Minimum pressure	14 PSI
Maximum pressure	145 PSI
Reccomended working pressure	30-70 PSI
Maximum water temperature	176°F
Maximum water temperature reccomended	150°F

ENGLAND.

Datos Técnicos

Pression mínima	14 PSI
Pression máxima	145 PSI
Pression de trabajo aconsejada	30-70 PSI
Temperatura máxima	176°F
Temperatura máxima aconsejada	150°F

SPAIN.

Advice on product care

To clean the surface use a soap and water solution.

Never use for any reason cleaning solutions containing abrasive substances, chloric acids, ammonia, vinegar, bleach, domestic acids, disinfectants, or any type of abrasive pad.

WARNING! Incorrect cleaning may permanently ruin the surface of the products and in such case the manufacturer may not be held liable for damage.

The Manufacturer reserves the right to modify product and accessories at any time without prior notice. Data, products and sketches included in this document are just for information and do not bind the producer.

ENGLAND.

Consejos para el cuidado del producto

La limpieza de las superficies se hace utilizando un jabón líquido diluido en agua.

No usar en ningún caso detergentes líquidos que contengan sustancias abrasivas o a base de ácido clorhídrico, estropajos abrasivos, amoníaco, acetona, lejía, ácidos de uso doméstico, desinfectantes varios.

ATENCIÓN! El uso de productos desaconsejados puede dañar irremediablemente las superficies de los elementos, de lo cual el fabricante no se hará responsable en ningún caso.

La sociedad se reserva el derecho de modificar sus productos y accesorios en cualquier momento y sin previo aviso.

SPAIN.

Notes / Notas

.....

.....

.....

.....

.....

.....

.....

.....

.....

.....

.....

.....

.....

.....

.....

.....

.....

.....

.....

.....

.....

.....

.....

.....

.....

.....

Notes / Notas

.....

.....

.....

.....

.....

.....

.....

.....

.....

.....

.....

.....

.....

.....

.....

.....

.....

.....

.....

.....

.....

.....

.....

.....

ABOUTWATER

118100001000000U Rev. 2

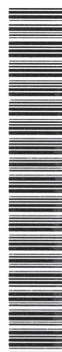

ABOUTWATER

Boffi FANTINI

Fratelli Fantini SpA

via Buonarroti, 4
28010 Pella (NO) Italia
T +39 0322 918411 r.a.
F +39 0322 969530
www.aboutwater.it
www.fantini.it
fantini@fantini.it