

ABOUTWATER

Instructions / Instructions De Montage / Instrucciones

EXTERNAL PARTS

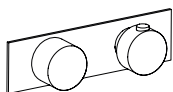

ART. A972BU

NECESSARY TOOLS - OUTILS NÉCESSAIRES - HERRAMIENTAS NECESARIAS

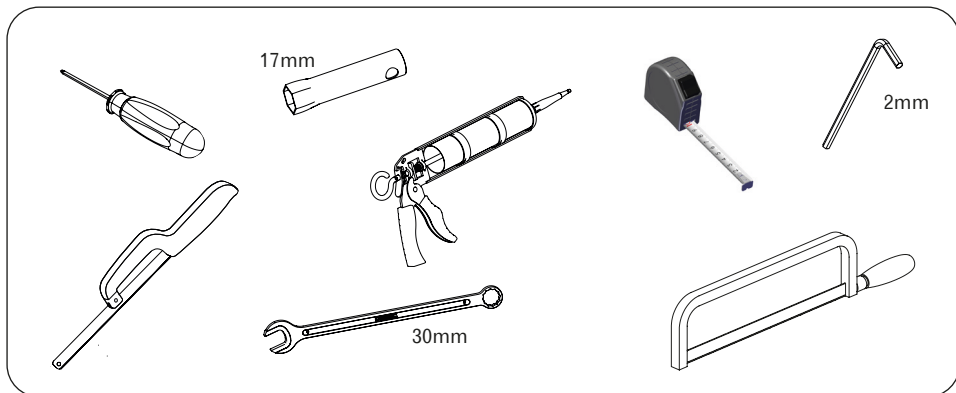

TECHINICAL DETAILS - DONNÉES TECHNIQUES - DATOS TÉCNICOS

EN	FR	ES	
Minimum pressure	Pression minimum	Pression mínima	1 BAR
Minimum pressure	Pression maximum	Pression máxima	10 BAR
Recommened working pressure	Pression optimale de service	Pression de trab. aconsejada	2-5 BAR
Max. water temperature	Température maximum	Temperatura máxima	80° C - 176° F
Maximum water temperature reccomended	Température maximum optimale	Temperatura máxima aconsejada	65° C - 149° F
Maximum in-let pressure diffe- rence (hot - cold)	Différence max. de pression d'arrivée (chaud - froid)	Diferencial max. de presiùn de entrada (caliente - fria)	1.5 BAR

EN If water pressure is above 5 bar, it is advisable to install a flow restrictor upstream of the water supply to avoid vibrations and regulate temperature.

FR Si la pression de l'eau est supérieure à 5 bar, il est recommandé d'installer un réducteur de pression en amont de l'alimentation afin d'éviter toute vibration et régulariser le réglage de la température.

ES Si la presión del agua supera los 5 bar, es preferible instalar un limitador de caudal en la conducción de la alimentación para evitar vibraciones y normalizar la regulación de la temperatura.

EN Advice on product care

To clean the surface use a soap and water solution. Never use for any reason cleaning solutions containing abrasive substances, chloric acids, ammonia, vinegar, bleach, domestic acids, disinfectants, or anytype of abrasive pad. WARNING! Incorrect cleaning may permanently ruin the surface of the products and in such case the manufacturer may not be held liable for damage. The Manufacturer reserves the right to modify product and accessories at any time without prior notice. Datos, products and sketches included in this document are just for information and do not bind the producer.

FR Conseils pour l'entretien du produit

La poussière en surface devra être faite en utilisant un savon liquide dilué dans l'eau. Ne jamais utiliser en aucun cas des détergents liquides contenant des substances abrasives ou à base d'acide, nid'éponges abrasives, vinaigre, ammoniaque, acétone, eau de Javel, acides à usage domestique, désinfectants divers. ATTENTION! L'emploi de produits non conseillés peut détériorer irrémédiablement la surface des articles pour lesquels le fabricant ne sera pas responsable.

La société se réserve le droit de modifier ses produits et ses accessoires à tout moment et sans préavis. Informations, produits et croquis reproduits dans ce documents sont de nature informative et ne sont pas contractuels.

ES Consejos para el cuidado del producto

La limpieza de las superficies se hace utilizando un jabón líquido diluido en agua. No usar en ningún caso detergentes líquidos que contengan sustancias abrasivas ó a base de ácido clorhídrico, estropajossabrasivos, amoniaco, acetona, lejía, ácidos de uso doméstico, desinfectantes varios. ATENCIÓN! El uso de productos desaconsejados puede danar irremediamente las superficies de los elementos, de lo cual el fabricante no se hará responsable en ningún caso. La sociedad se reserva el derecho de realizar cambios en los productos y accesorios en cualquier momento sin previo aviso. Los datos reproducidos en este documento son informativos y no vinculantes.

A972BU+D331AU

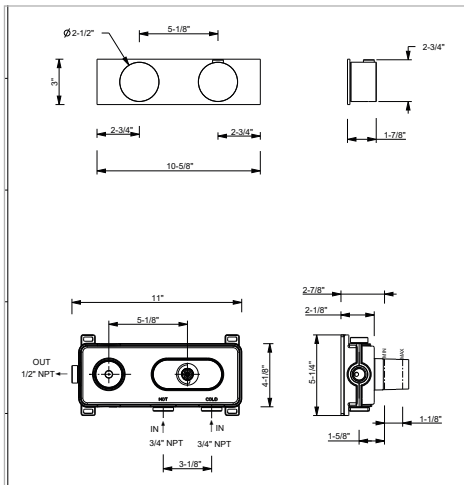

A972BU+D372AU

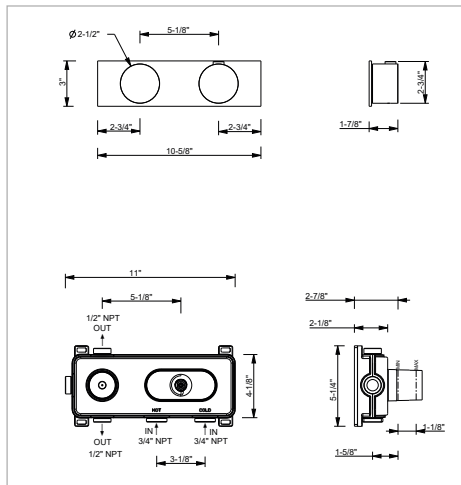

A972BU+D373AU

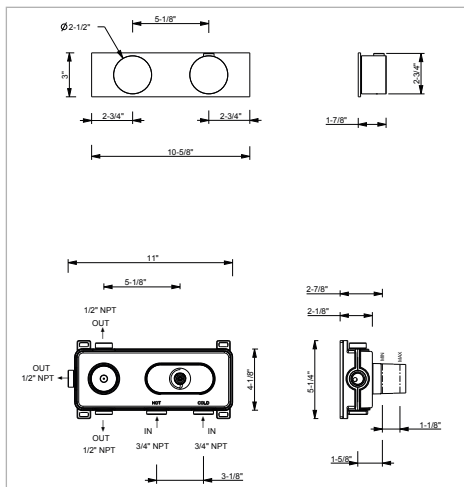

- EN** These mixers can be used with high-pressure hot water accumulators or with instant water heaters.
- FR** Ces mitigeurs peuvent être utilisés avec des accumulateurs d'eau chaude à pression ou avec des chauffe-eau instantanés.
- ES** Estos monomandos pueden utilizarse con acumuladores de agua caliente a presión o con calentadores instantáneos.

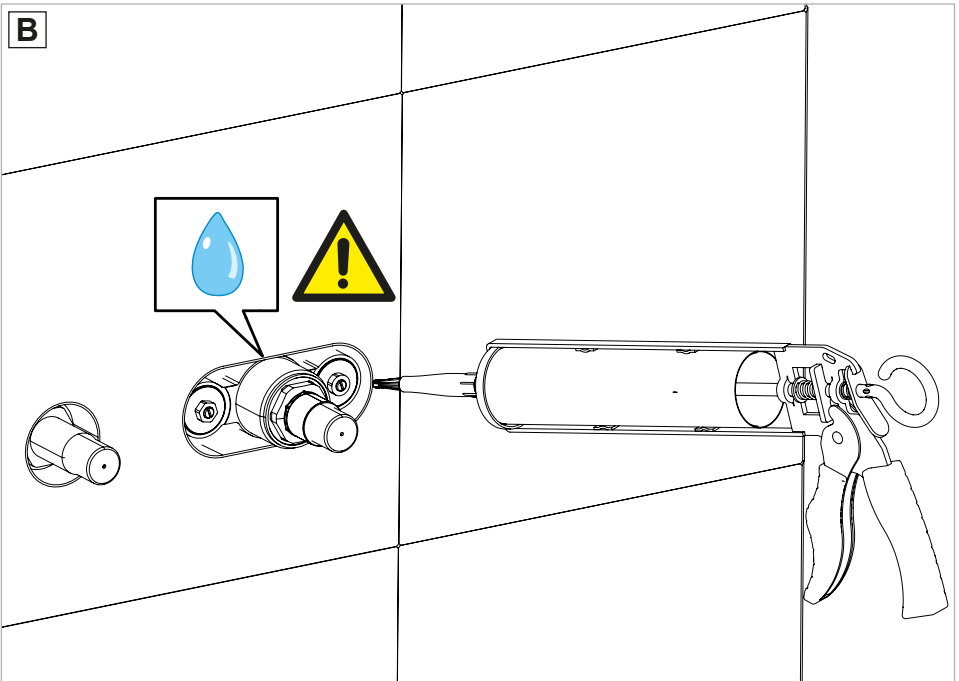
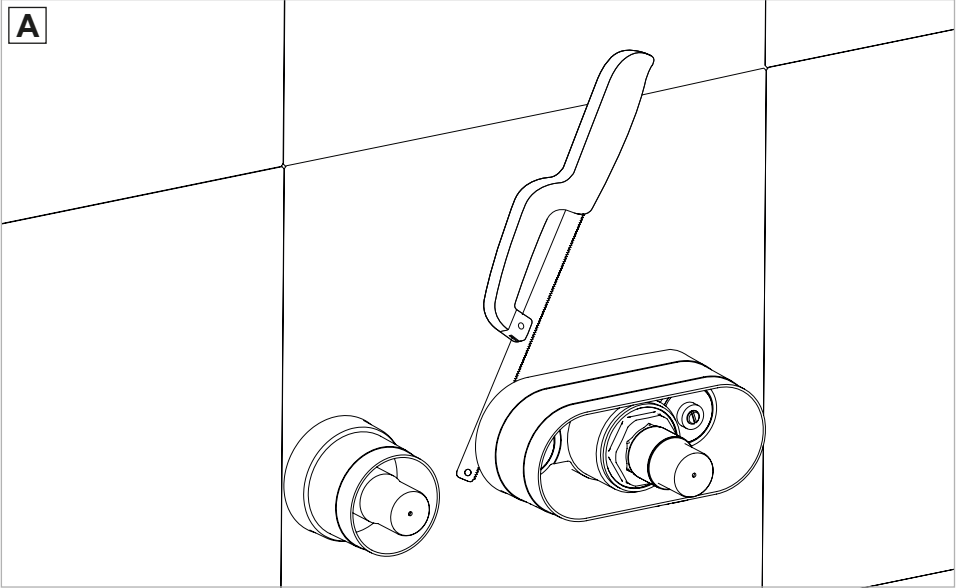

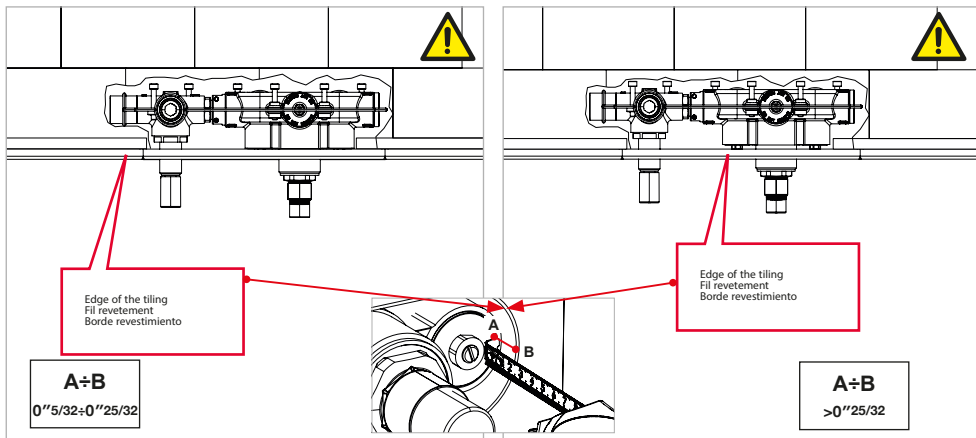

1

If the distance is greater than 0''25/32, continue from page 10 Figure 1.

Si la distance est supérieure à 0''25/32, continuez à partir de la page 10 Graphique 1.

Si la distancia es superior a 0''25/32, continúe desde la página 10 Figura 1.

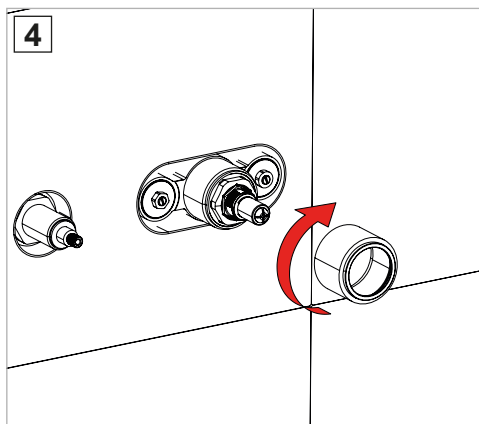
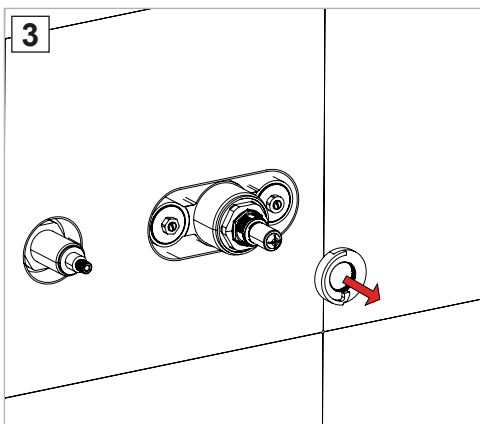
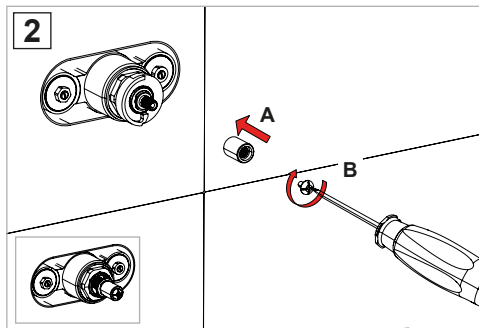
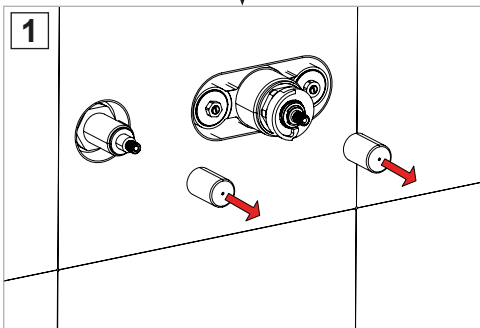

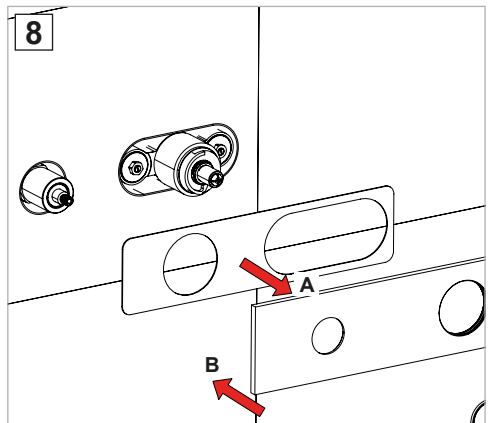
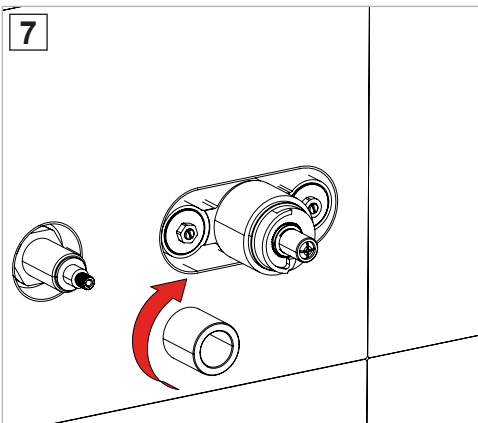
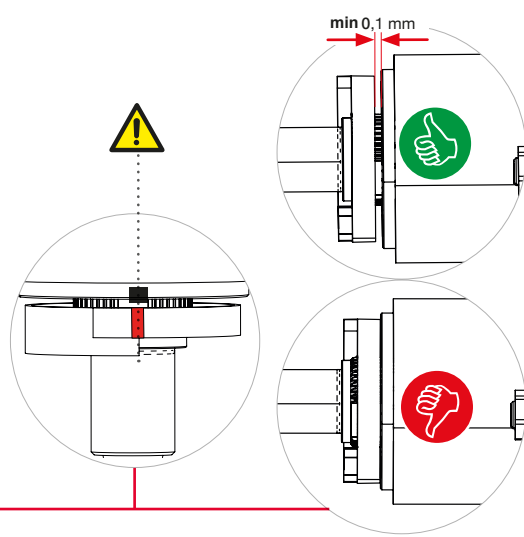
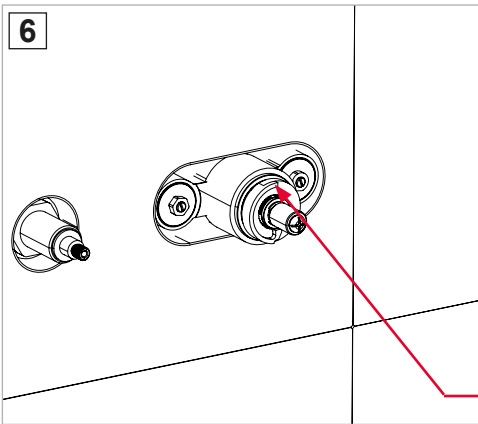
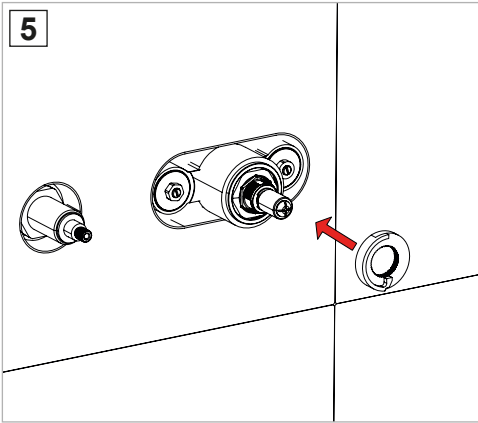

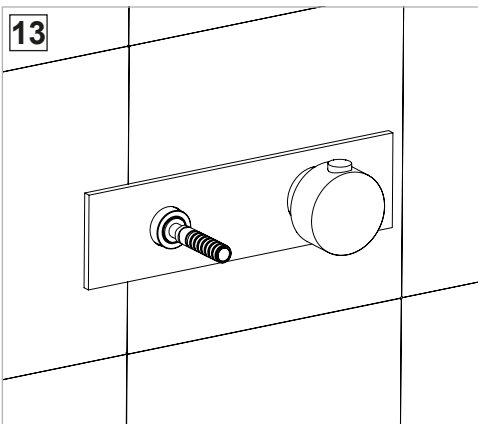
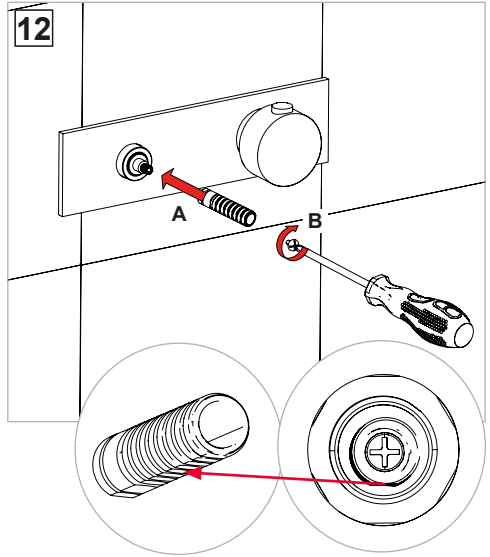
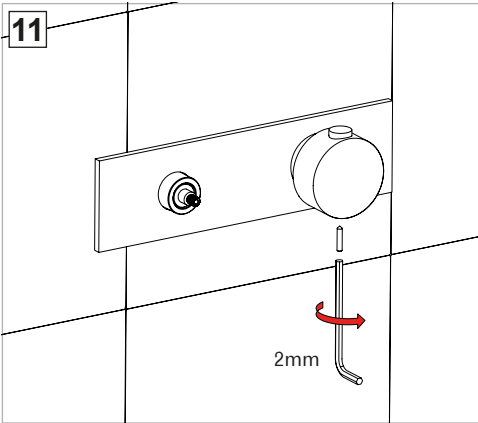
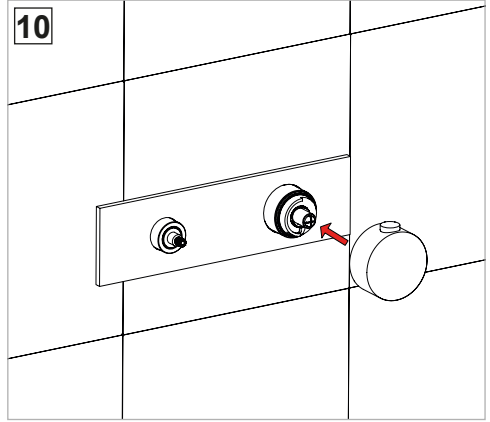
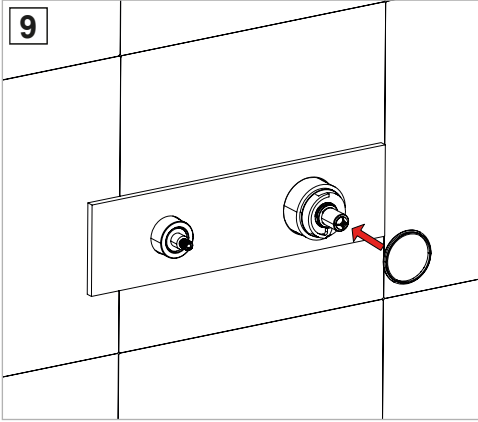

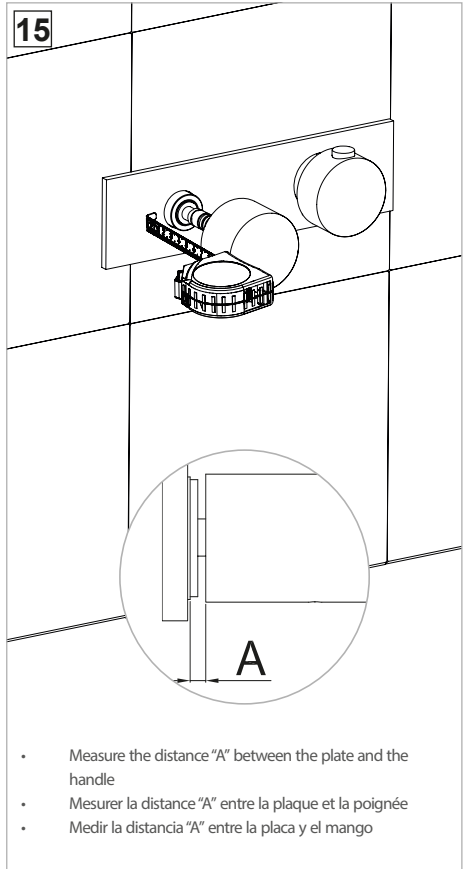
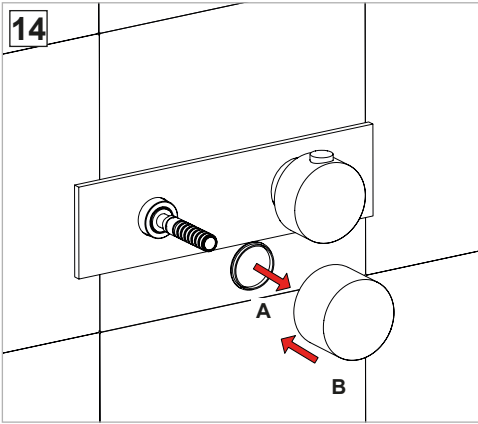

- Measure the distance "A" between the plate and the handle
- Mesurer la distance "A" entre la plaque et la poignée
- Medir la distancia "A" entre la placa y el mango

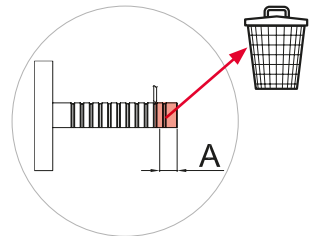
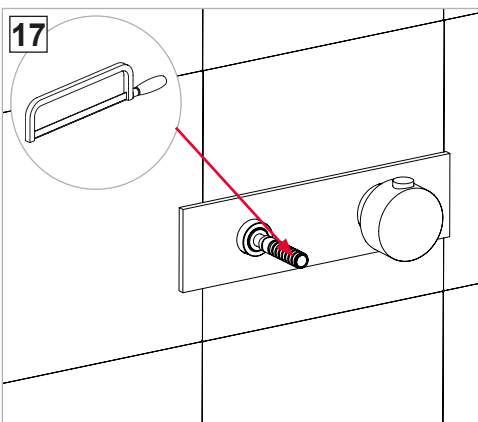
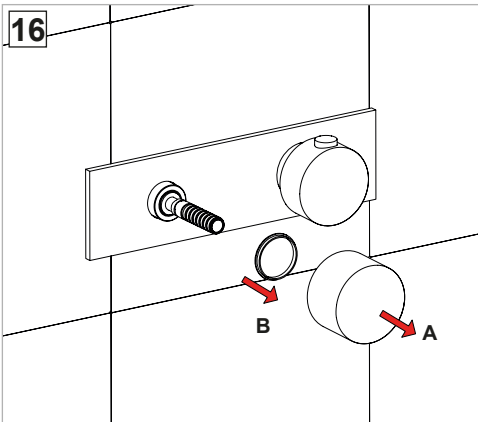

- Cut the adapter by removing the measure "A" previously measured
- Couper l'adaptateur en retirant la mesure "A" précédemment mesurée
- Corte el adaptador mediante la eliminación de la medida "A" medido previamente

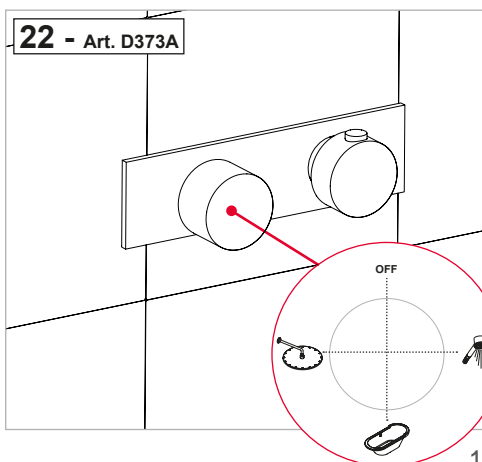
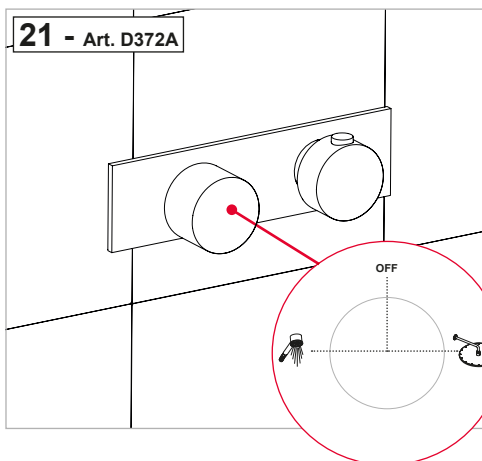
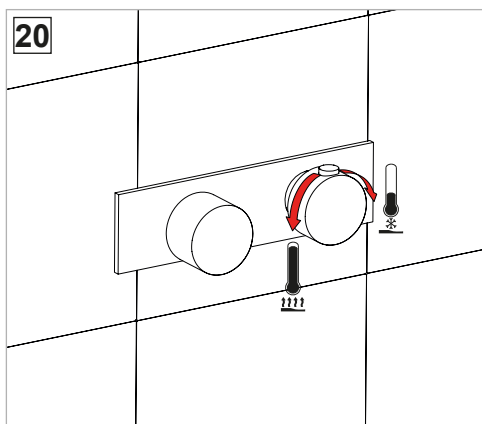
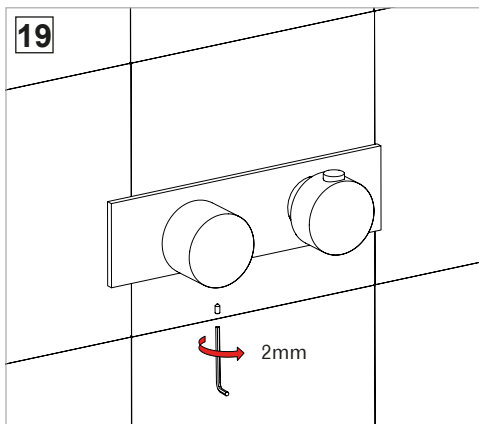
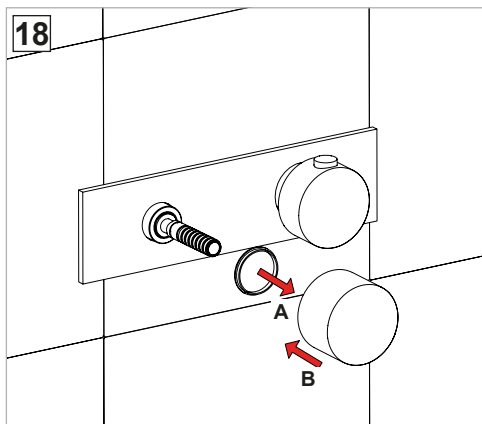

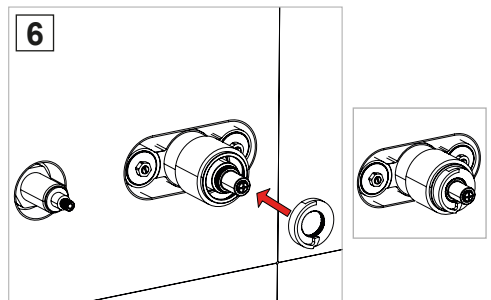
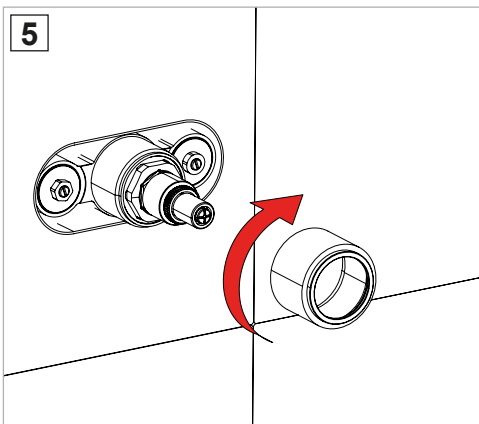
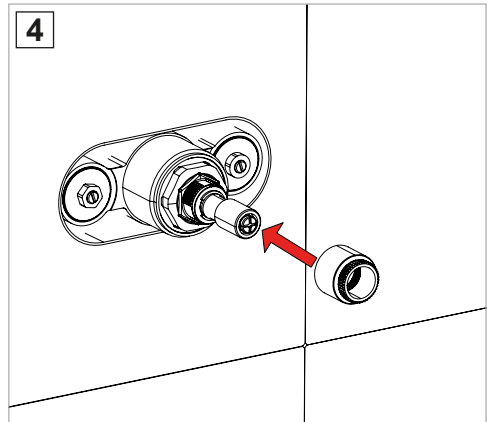
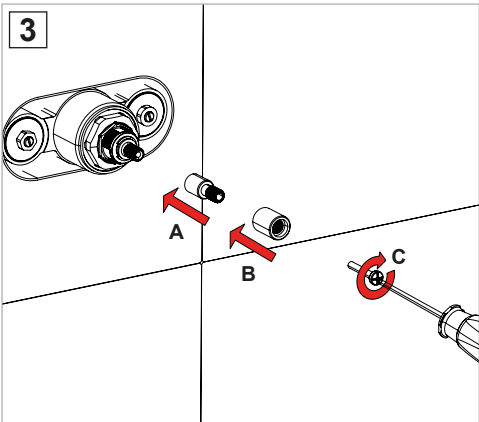
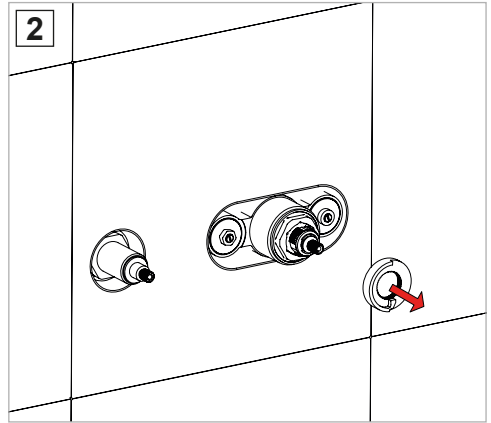
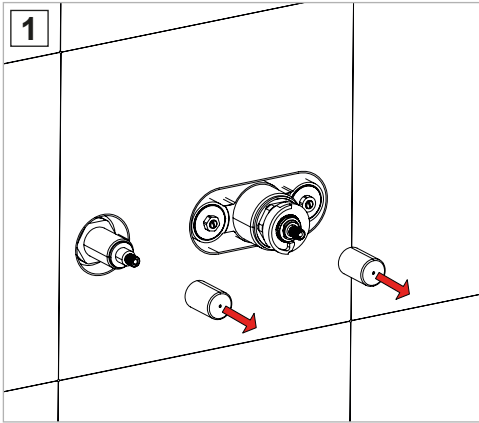
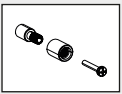

- Continue the installation from p. 7 figure 5.
- Continuez l'installation à partir de la p. 7 figure 5.
- Continúe con la instalación desde la pág. 7 Figura 5.

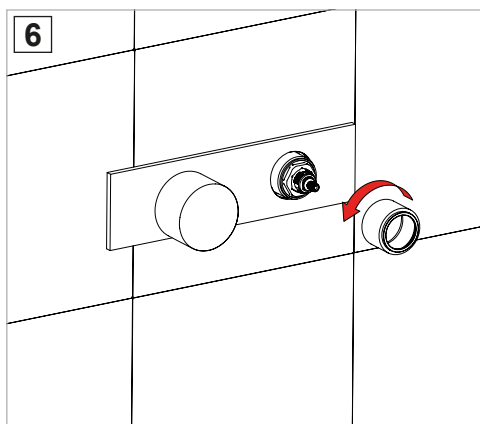
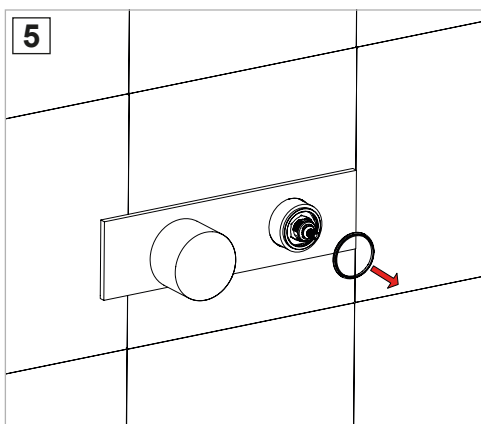
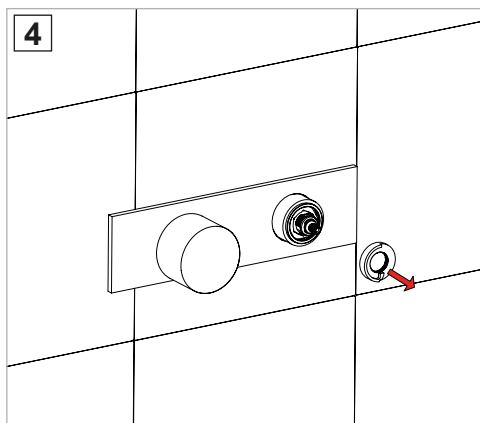
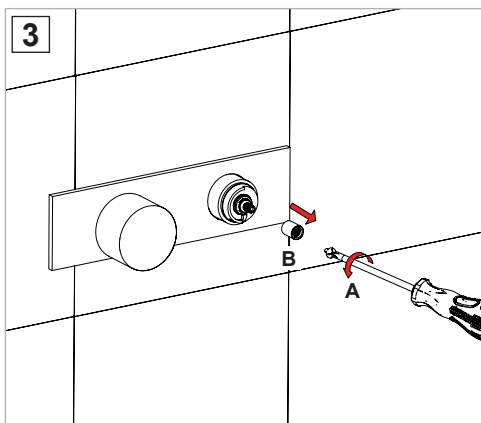
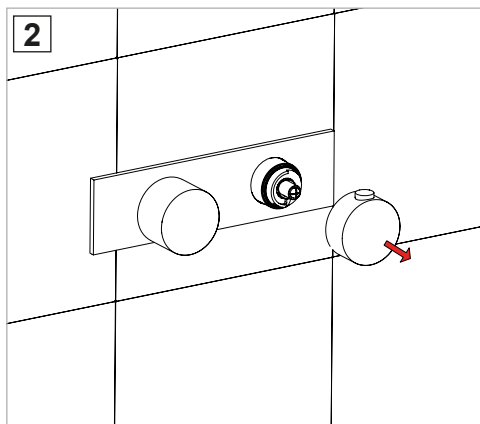
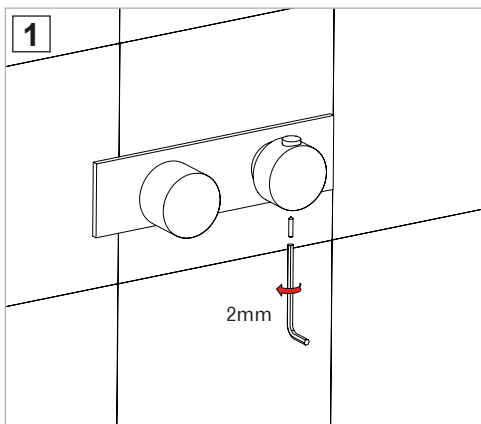



CARTRIDGE REPLACEMENT - REMPLACEMENT DE LA CARTOUCHE - SOSTITUION DEL CARTUCHO

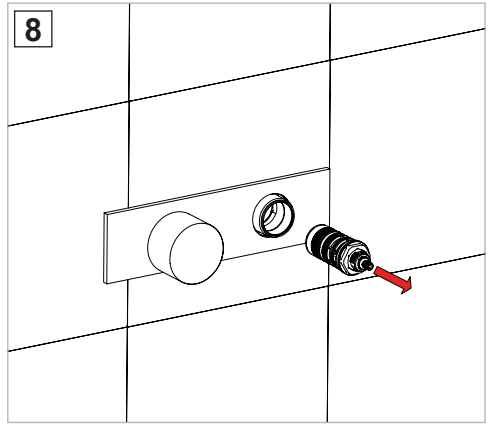
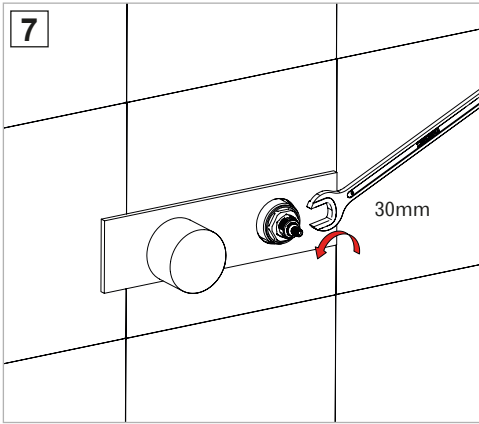

- Replace following the instructions in reverse order (8-7-6-5-4-3-2-1).
- Re-installer au contraire du procédé (8-7-6-5-4-3-2-1).
- Colocar según el procedimiento inverso (8-7-6-5-4-3-2-1).

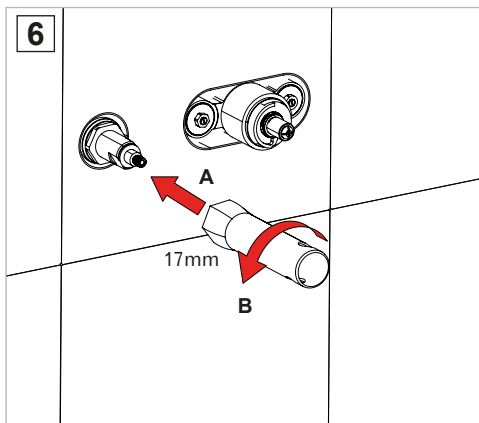
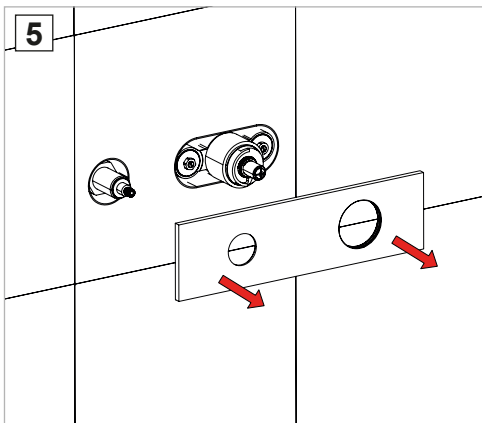
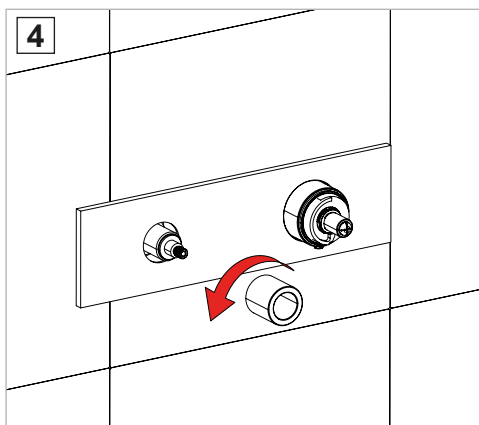
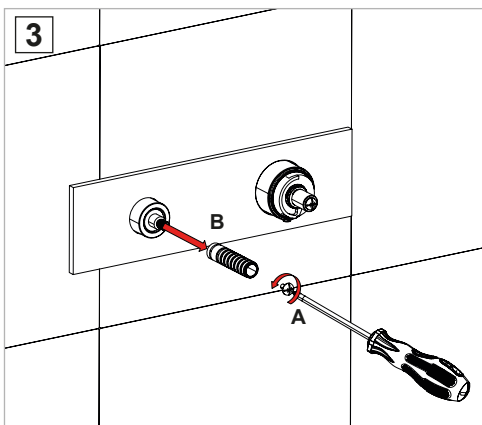
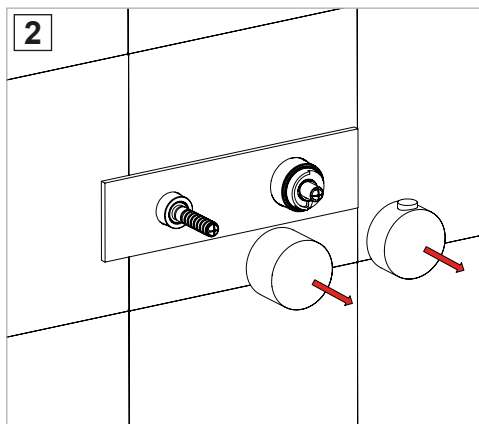
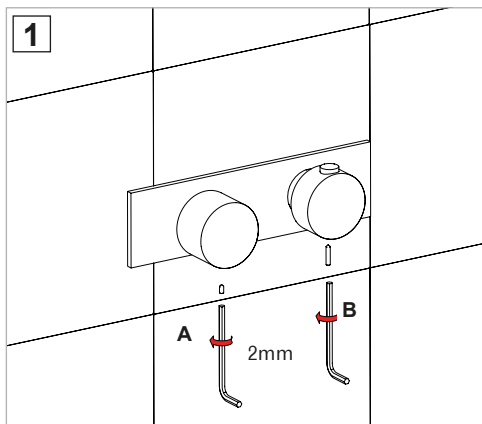
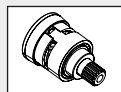

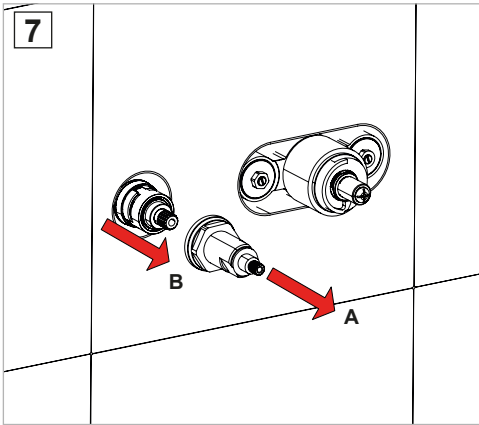
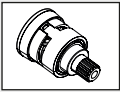

- Replace following the instructions in reverse order (7-6-5-4-3-2-1).
- Re-installer au contraire du procédé (7-6-5-4-3-2-1).
- Colocar según el procedimiento inverso (7-6-5-4-3-2-1).

ABOUTWATER

112700031000000U Rev. 0



ABOUTWATER

Boffi FANTINI

Fratelli Fantini SpA

via Buonarroti, 4
28010 Pella (NO) Italia
T +39 0322 918411 r.a.
F +39 0322 969530
www.aboutwater.it
www.fantini.it
fantini@fantini.it