

Instructions / Instructions De Montage / Instrucciones

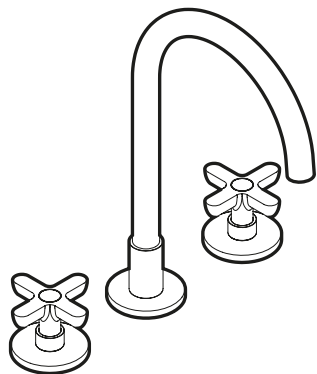

CLASSIC R007U  
R007WU

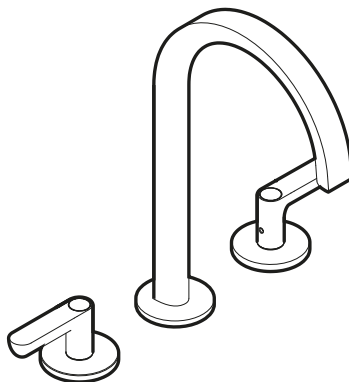

DECO R107U  
R107WU

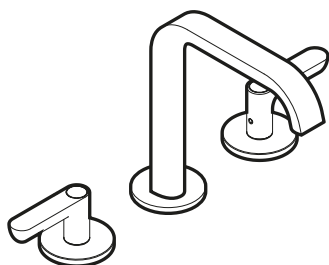

DECO R106U  
R106WU

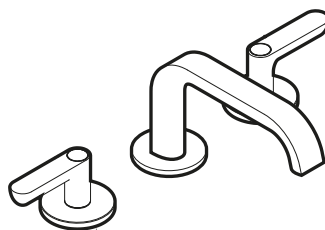

DECO R104U  
R104WU

### CLASSIC R007U

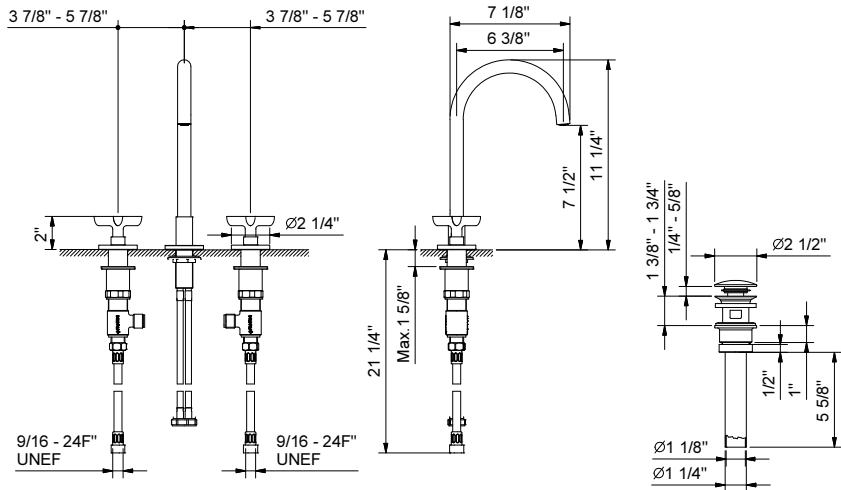

### CLASSIC R007WU

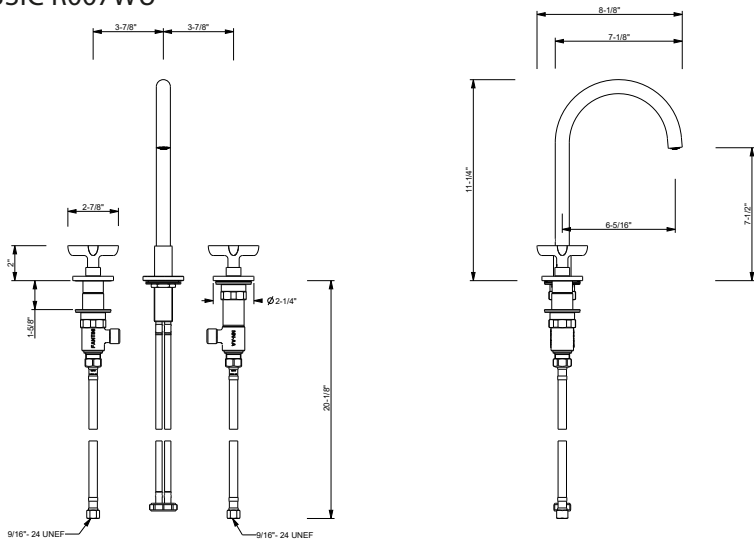

**EN** These mixers can be used with high-pressure hot water accumulators or with instant water heaters.

**FR** Ces mitigeurs peuvent être utilisés avec des accumulateurs d'eau chaude à pression ou avec des chauffe-eau instantanés.

**ES** Estos monomandos pueden utilizarse con acumuladores de agua caliente a presión o con calentadores instantáneos.

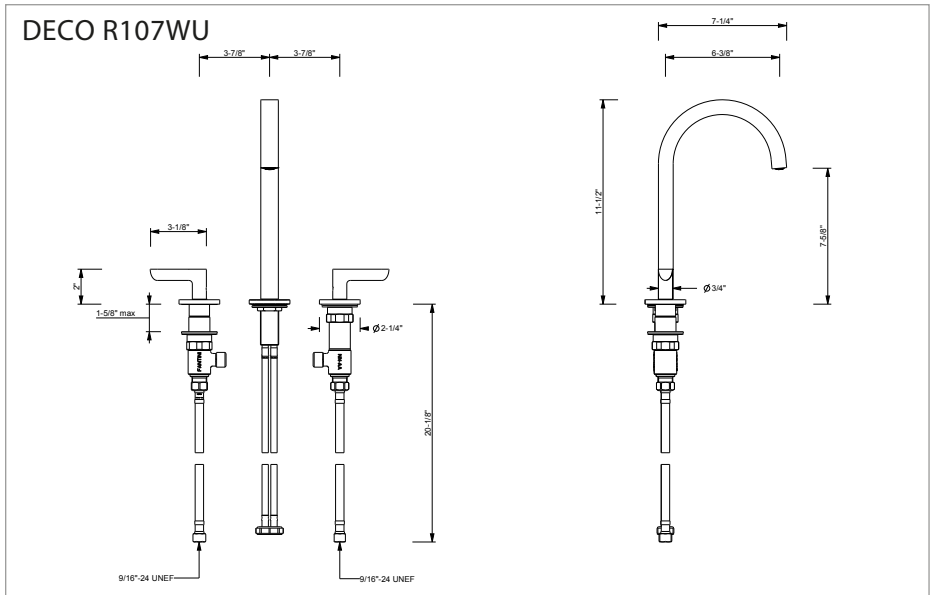
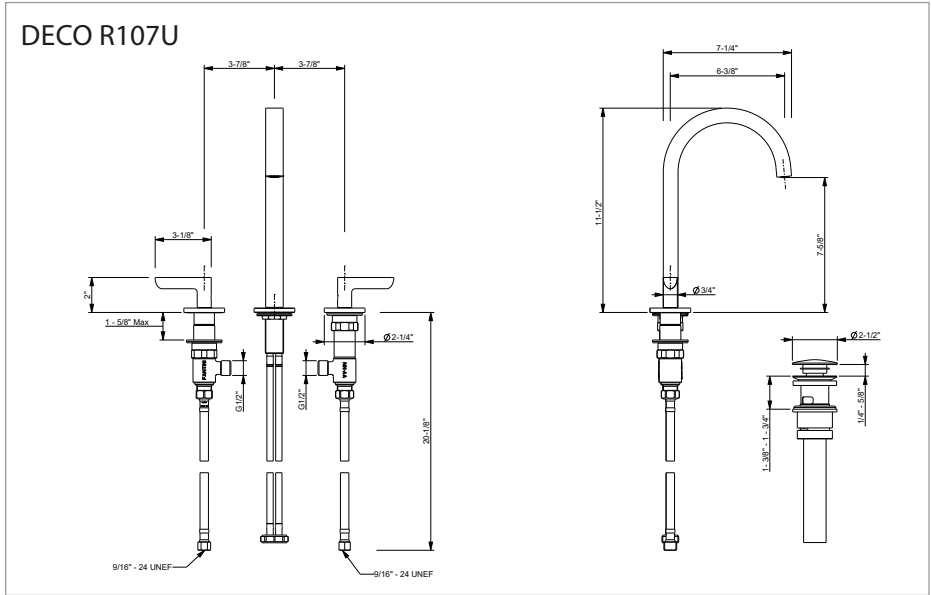

- EN** These mixers can be used with high-pressure hot water accumulators or with instant water heaters.
- FR** Ces mitigeurs peuvent être utilisés avec des accumulateurs d'eau chaude à pression ou avec des chauffe-eau instantanés.
- ES** Estos monomandos pueden utilizarse con acumuladores de agua caliente a presión o con calentadores instantáneos.

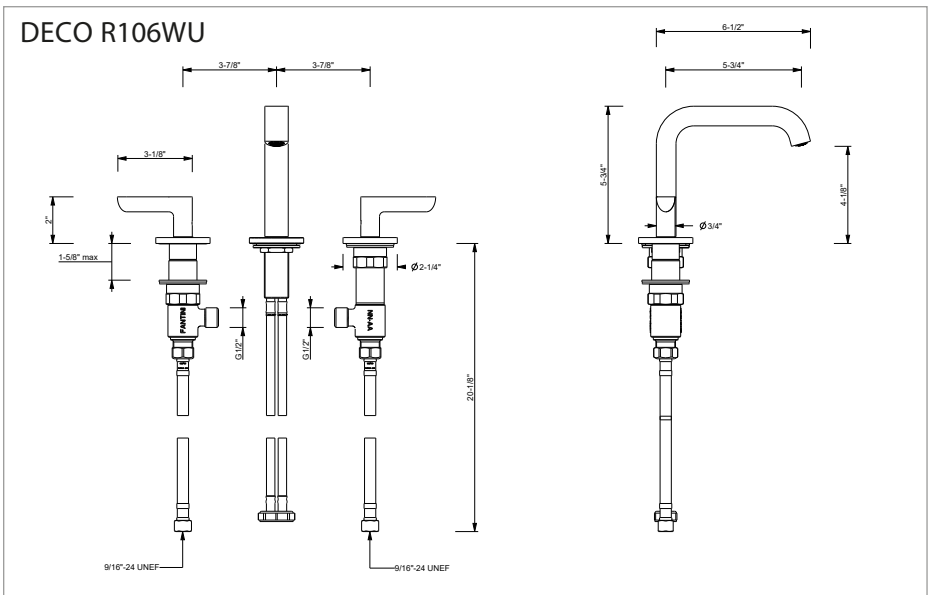
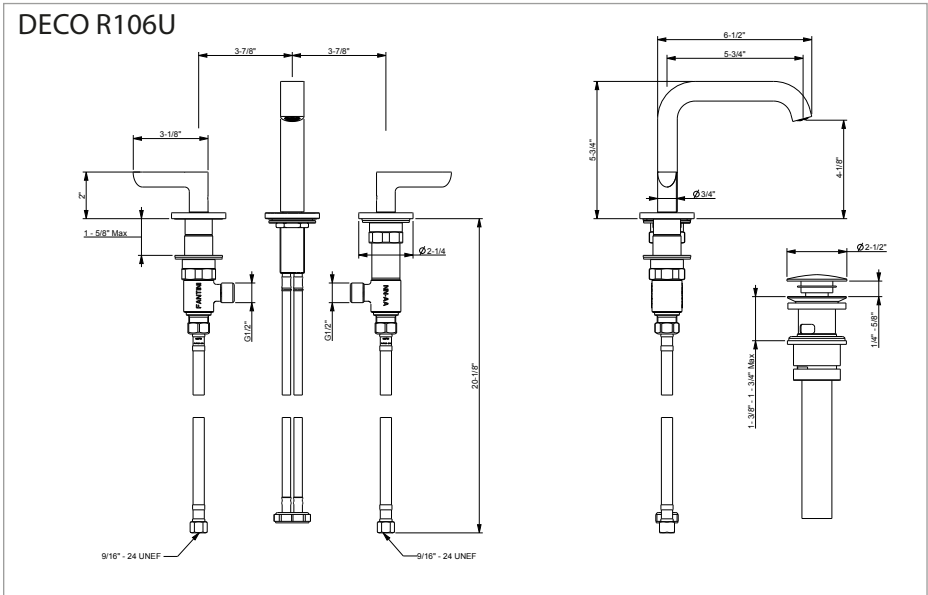

- EN** These mixers can be used with high-pressure hot water accumulators or with instant water heaters.
- FR** Ces mitigeurs peuvent être utilisés avec des accumulateurs d'eau chaude à pression ou avec des chauffe-eau instantanés.
- ES** Estos monomandos pueden utilizarse con acumuladores de agua caliente a presión o con calentadores instantáneos.



### DECO R104U

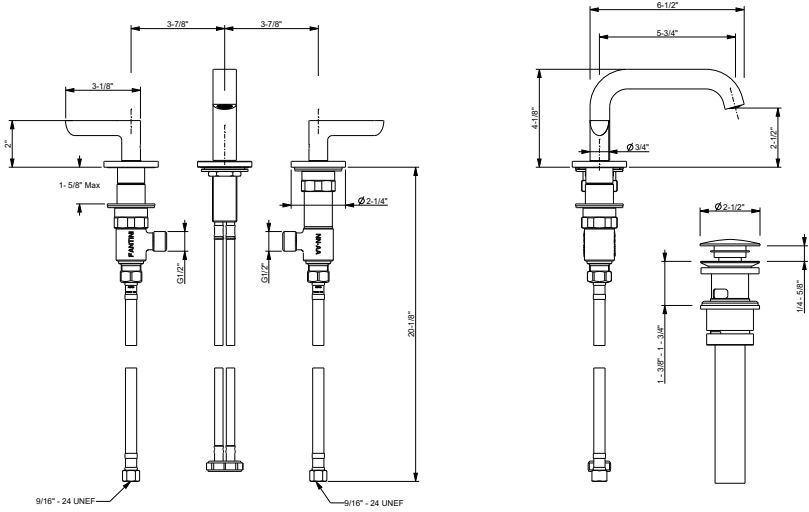

### DECO R104WU

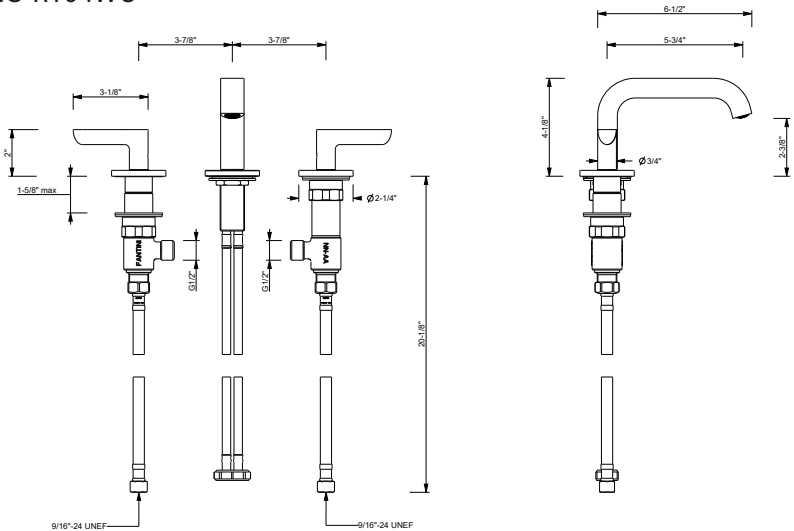

**EN** These mixers can be used with high-pressure hot water accumulators or with instant water heaters.

**FR** Ces mitigeurs peuvent être utilisés avec des accumulateurs d'eau chaude à pression ou avec des chauffe-eau instantanés.

**ES** Estos monomandos pueden utilizarse con acumuladores de agua caliente a presión o con calentadores instantáneos.

# TECHNICAL DETAILS - DONNÉES TECHNIQUES - DATOS TÉCNICOS

EN	FR	ES	
Minimum pressure	Pression minimum	Pression mínima	1 BAR
Maximum pressure	Pression maximum	Pression máxima	10 BAR
Recommened working pressure	Pression optimale de service	Pression de trab. aconsejada	2-5 BAR
Max. water temperature	Température maximum	Temperatura máxima	80° C 176° F
Maximum water temperature reccomended	Température maximum optimale	Temperatura máxima aconsejada	65° C 149° F
Maximum in-let pressure difference (hot - cold) 1.5 BAR	Diffèrence max. de pression d'arrivée (chaud - froid)	Diferencial max. de presiùn de entrada (caliente - fria)	1.5 BAR

**EN** If water pressure is above 5 bar, it is advisable to install a flow restrictor upstream of the water supply to avoid vibrations and regulate temperature.

**FR** Si la pression de l'eau est supérieure à 5 bar, il est recommandé d'installer un réducteur de pression en amont de l'alimentation afin d'éviter toute vibration et régulariser le réglage de la température.

**ES** Si la presión del agua supera los 5 bar, es preferible instalar un limitador de caudal en la conducción de la alimentación para evitar vibraciones y normalizar la regulación de la temperatura.

## NECESSARY TOOLS - OUTILS NÉCESSAIRES - HERRAMIENTAS NECESARIAS

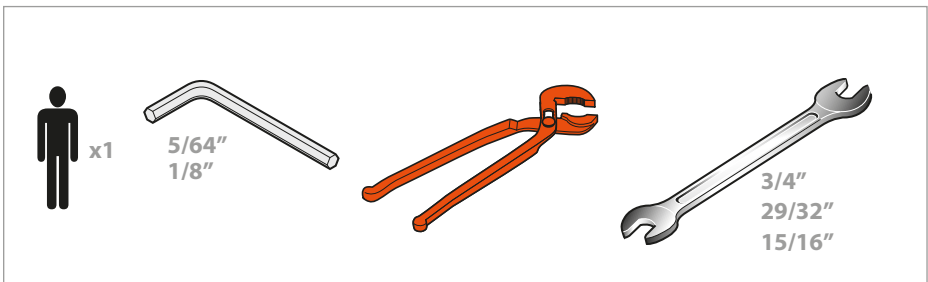

EN

**INSTALLING THE FLEXIBLE HOSES (SUPPLIED): warning**

Only use the flexible hoses supplied. Check for the presence and perfect condition of the seaming on either side of the flexible hoses before installation. Screw on the connectors with an OR seal by hand (maximum tightening torque of 3 Nm). Screw on the connectors with a gasket seal (nuts) by hand and next tighten by a quarter of a turn with an appropriate spanner. Prolonged contact with substances, even blandly aggressive, may damage the braid and consequently cause the flexible hose to be damaged. Do not connect the electrical system earthing to the flexible hose or to another plumbing pipe. Replace the flexible hose in the event of small leaks. We recommend the installation of underbasin filters.

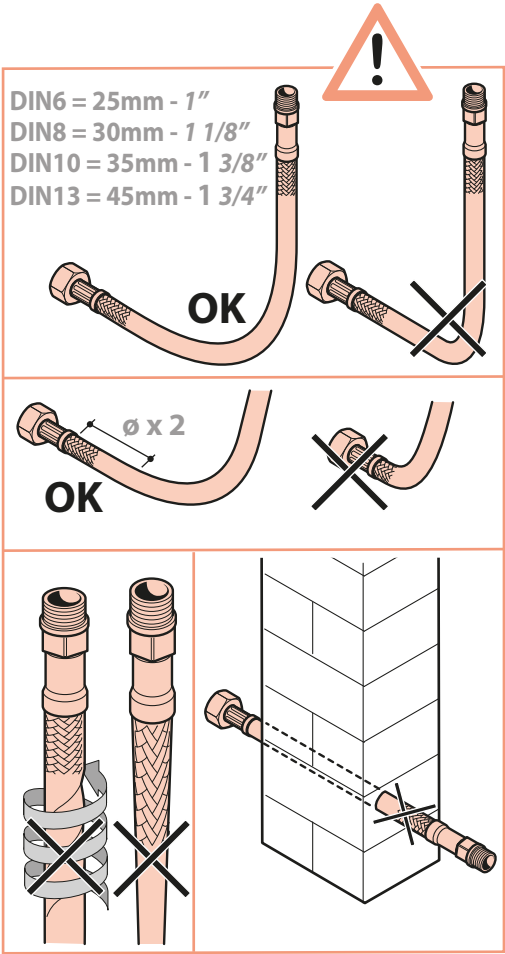

FR

**INSTALLATION DES FLEXIBLES (FOURNIS) : recommandations**

N'utiliser que les flexibles fournis. Avant l'installation, contrôler que les agrafes des flexibles soient présentes et intactes des deux côtés. Visser les raccords avec joint d'étanchéité O.R. à la main (couple de serrage maximum 3 Nm). Visser les raccords avec joint d'étanchéité (écrous) à la main, plus un 1/4 de tour avec une clé appropriée. Le contact prolongé avec des substances, même si peu agressives, peut endommager la tresse avec conséquente rupture du flexible. Ne pas raccorder la mise à la terre de l'installation au flexible ou à une autre conduite hydraulique. Remplacer le flexible en cas de petites pertes.

L'installation de robinets sous lavabo avec filtre est conseillée.

ES

**INSTALACIÓN DE LOS FLEXOS (INCLUIDOS): advertencias**

Utilice únicamente los flexos incluidos. Antes de la instalación, comprobar que las conexiones de los flexos estén tengan sus juntas en los dos extremos y en buen estado. Enroscar a mano los racords con junta tórica (máximo par de apriete: 3 Nm). Enroscar los racords con junta (tuercas), antes a mano y luego 1/4 de vuelta con una llave adecuada. El contacto prolongado con sustancias mínimamente agresivas puede estropear el trenzado y, por lo tanto, provocar que se dañe el flexo. No conectar la toma de tierra de la instalación eléctrica al flexo o a otros conductos de agua. Cambiar el flexo si se detectan pequeñas pérdidas. Se recomienda instalar llaves de paso con filtro bajo el fregadero.

CLASSIC  
R007U  
R007WU



ASSEMBLY PHASES  
PHASE D'ASSEMBLAGE  
FASES DE MONTAJE

1	2	3	4
5	6	7	

DECO  
R107U  
R107WU

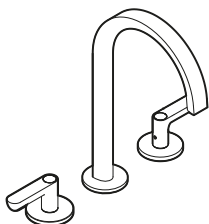

ASSEMBLY PHASES  
PHASE D'ASSEMBLAGE  
FASES DE MONTAJE

1	2	3	8
9	10	11	

DECO  
R104U  
R104WU  
R106U  
R106WU

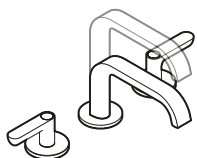

ASSEMBLY PHASES  
PHASE D'ASSEMBLAGE  
FASES DE MONTAJE

1	2	3	12
13	14	15	



1

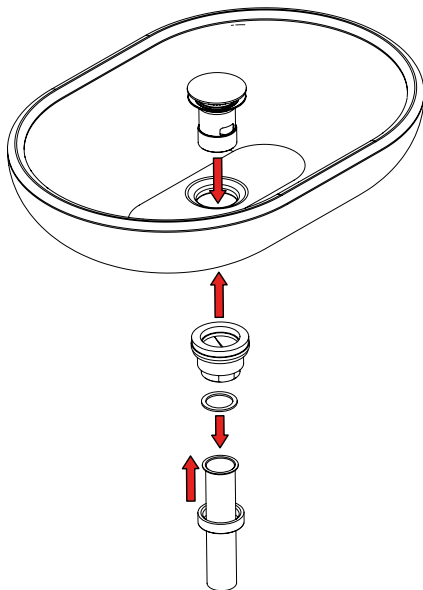

2

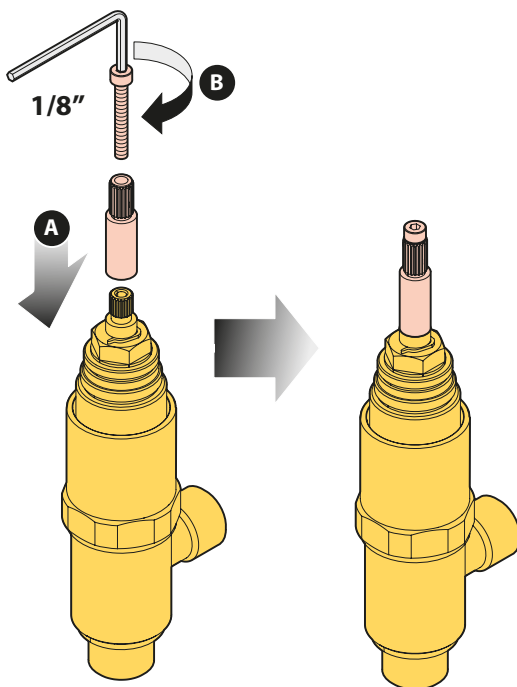

3

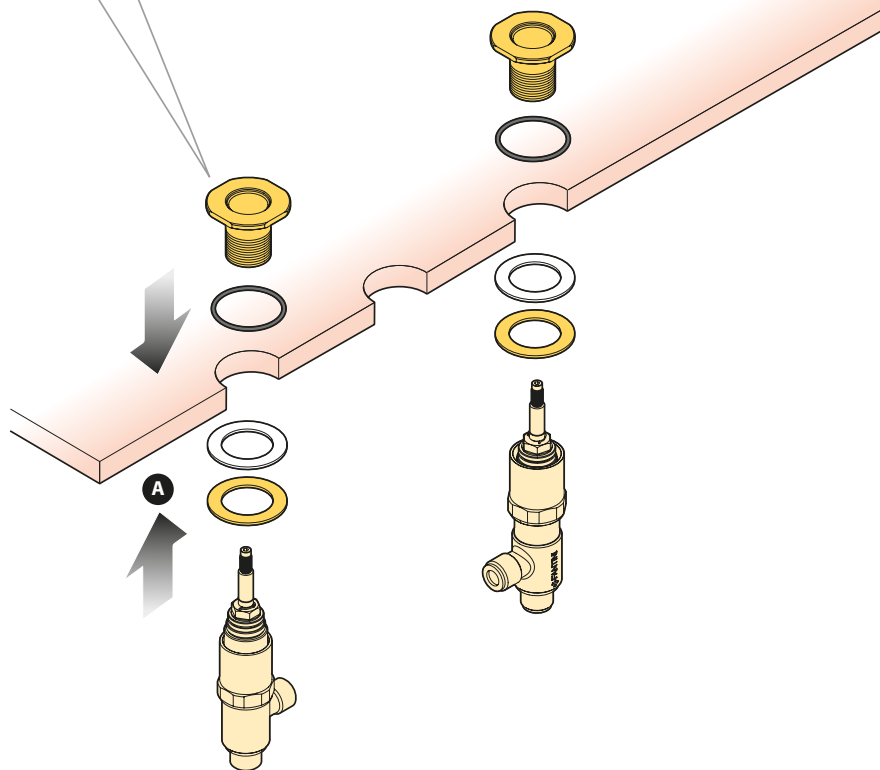
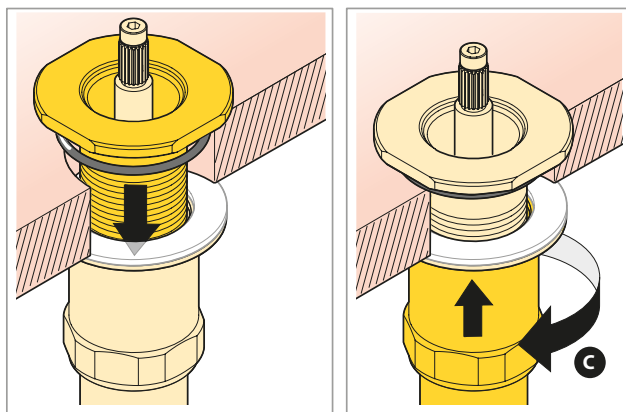

CLASSIC  
R007U  
R007WU



ASSEMBLY PHASES  
PHASE D'ASSEMBLAGE  
FASES DE MONTAJE

4

5

6

7

pag. 12

DECO  
R107U  
R107WU



ASSEMBLY PHASES  
PHASE D'ASSEMBLAGE  
FASES DE MONTAJE

8

9

10

11

pag. 16

DECO  
R104U  
R104WU  
R106U  
R106WU

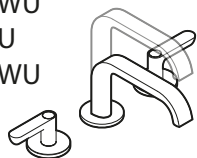

ASSEMBLY PHASES  
PHASE D'ASSEMBLAGE  
FASES DE MONTAJE

12

13

14

15

pag. 20

4

ICONA CLASSIC R007U - R007WU

CLASSIC  
R007U  
R007WU



5/64"

B



A

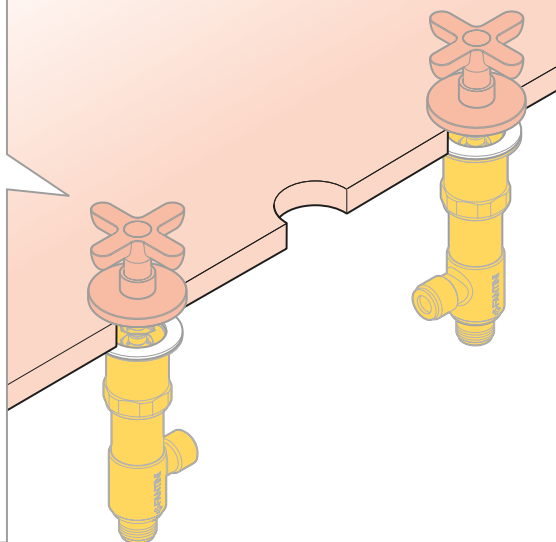
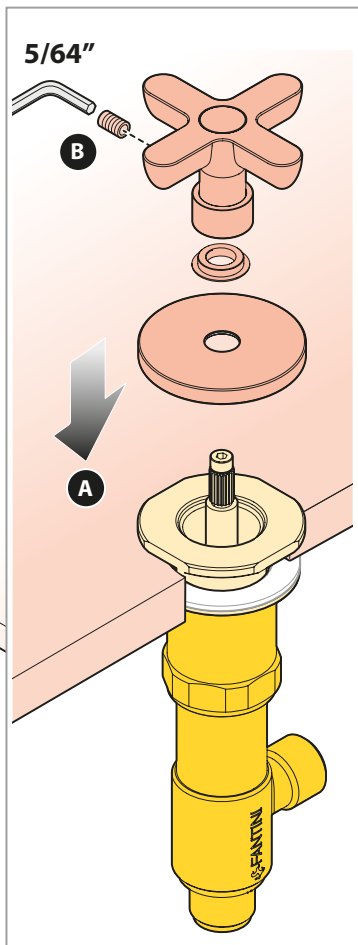

5

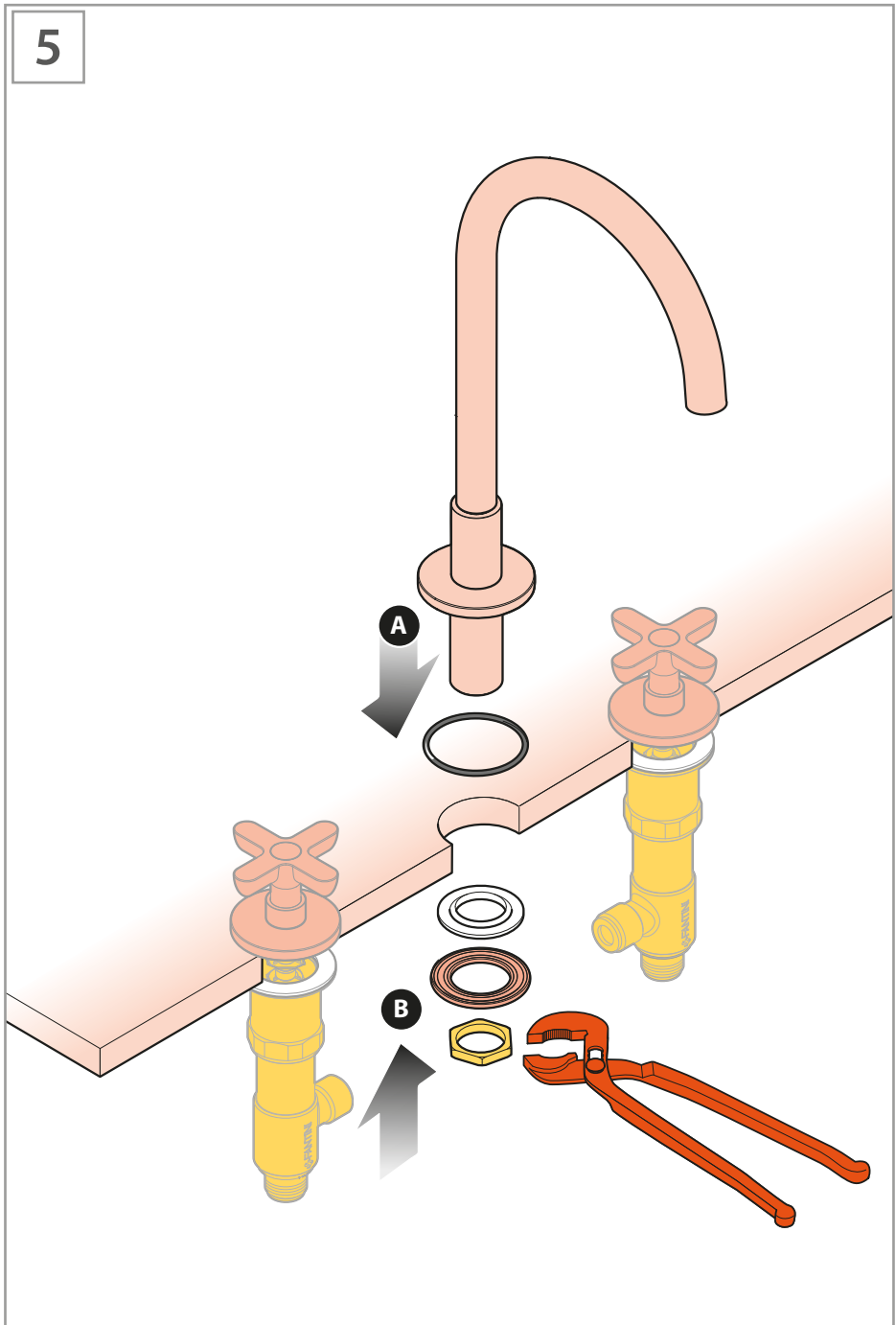

6

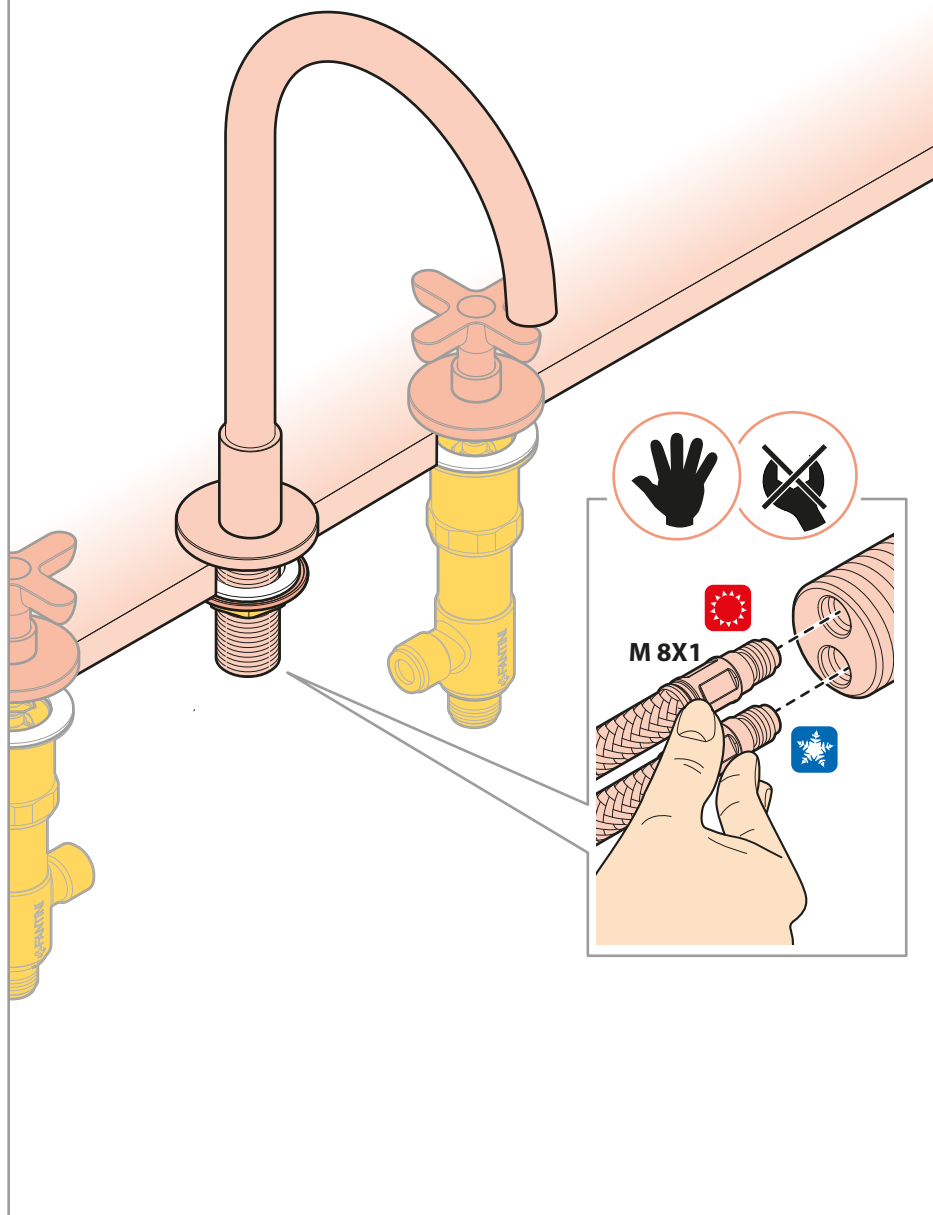

7

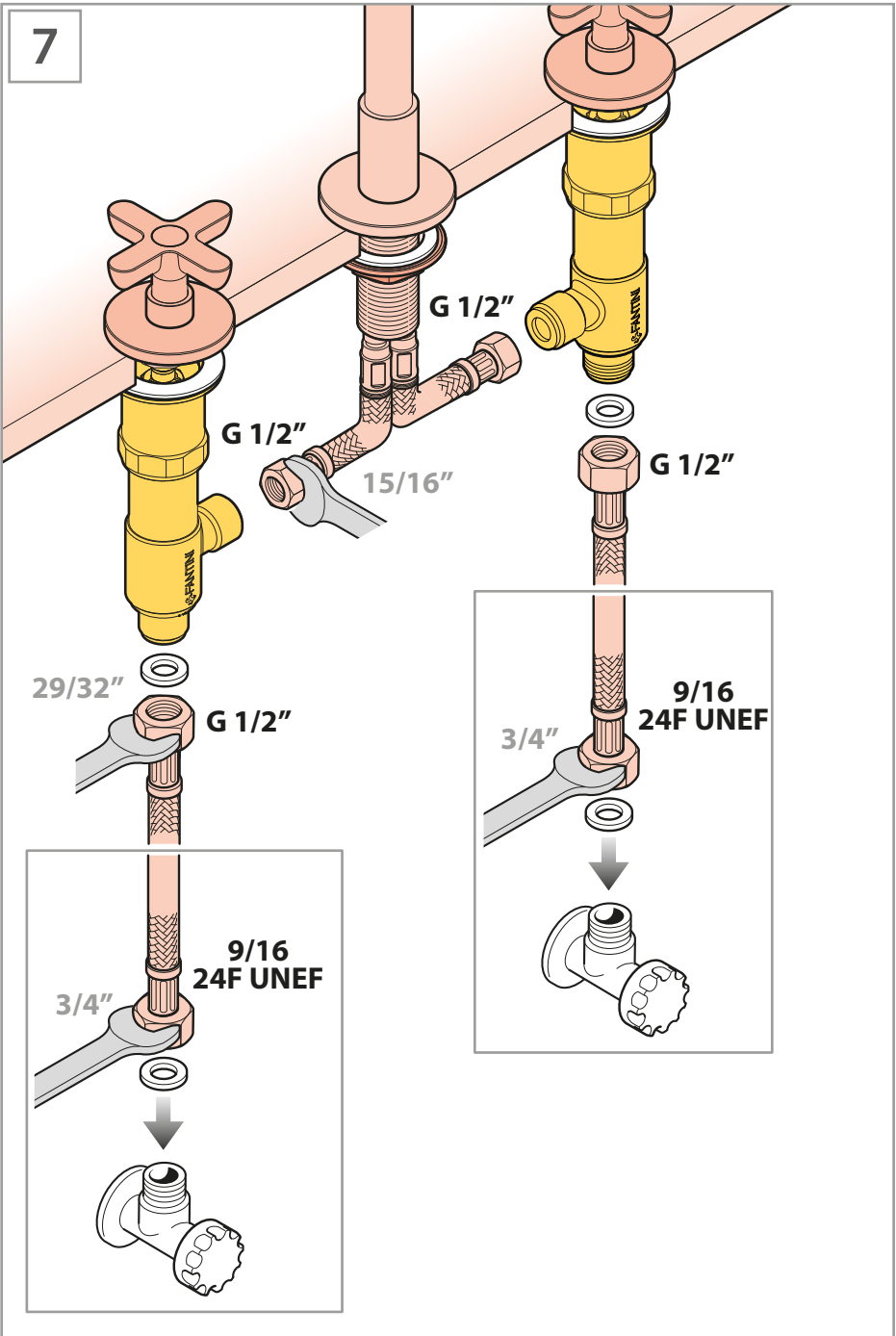

8

ICONA DECO R107U - R107WU

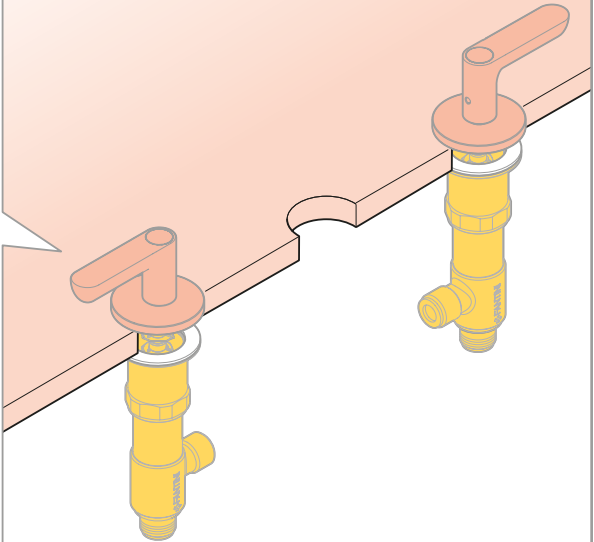
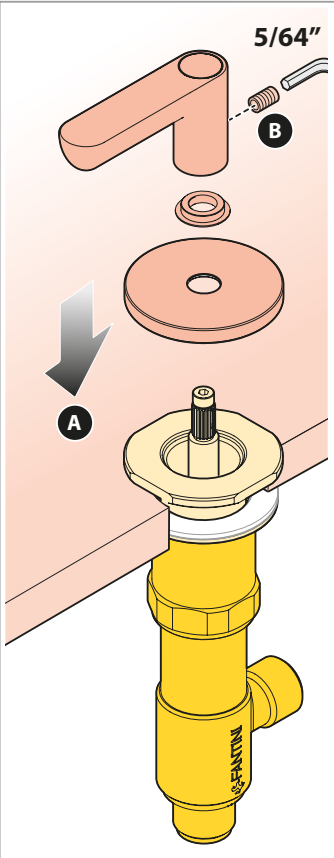



9

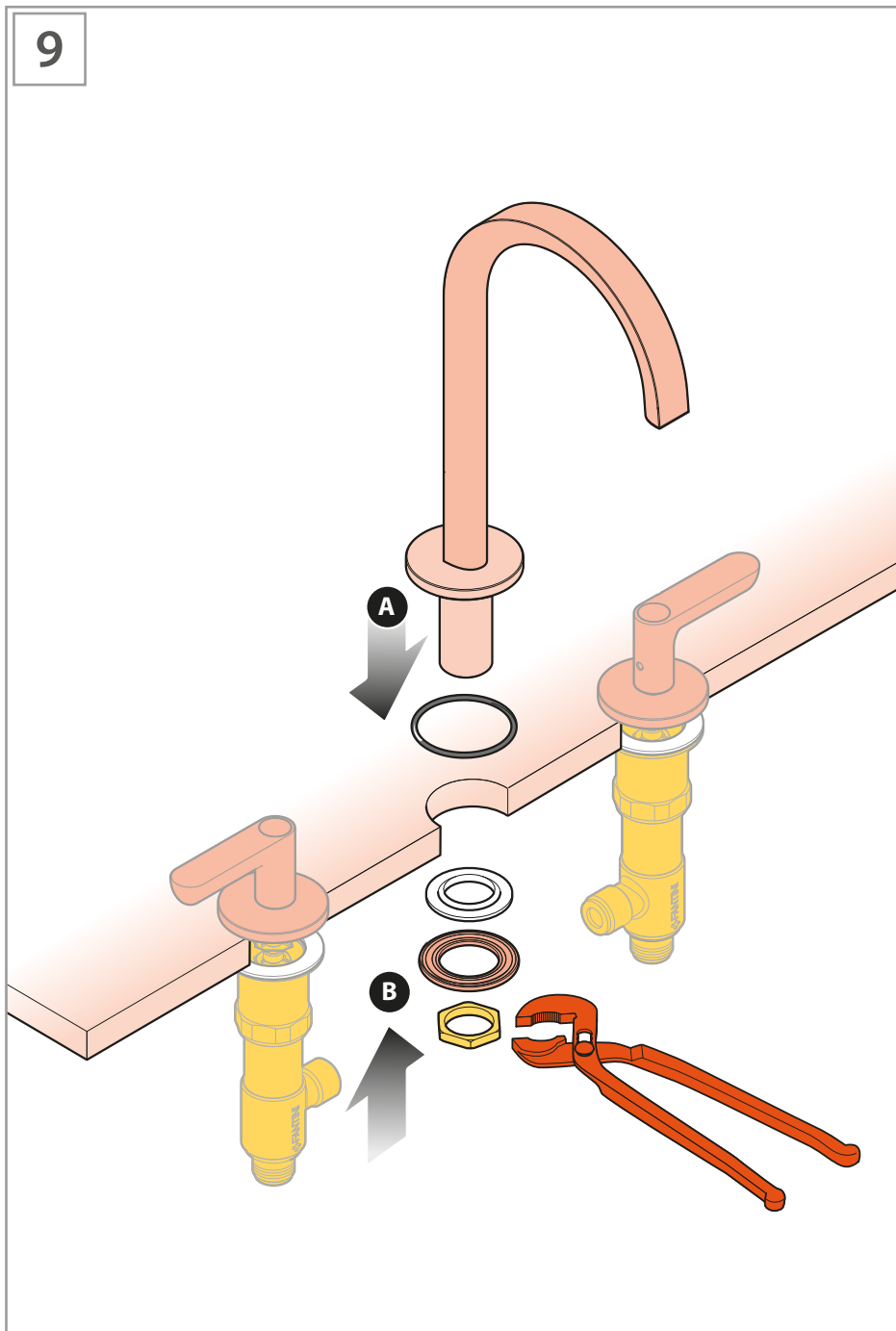

10

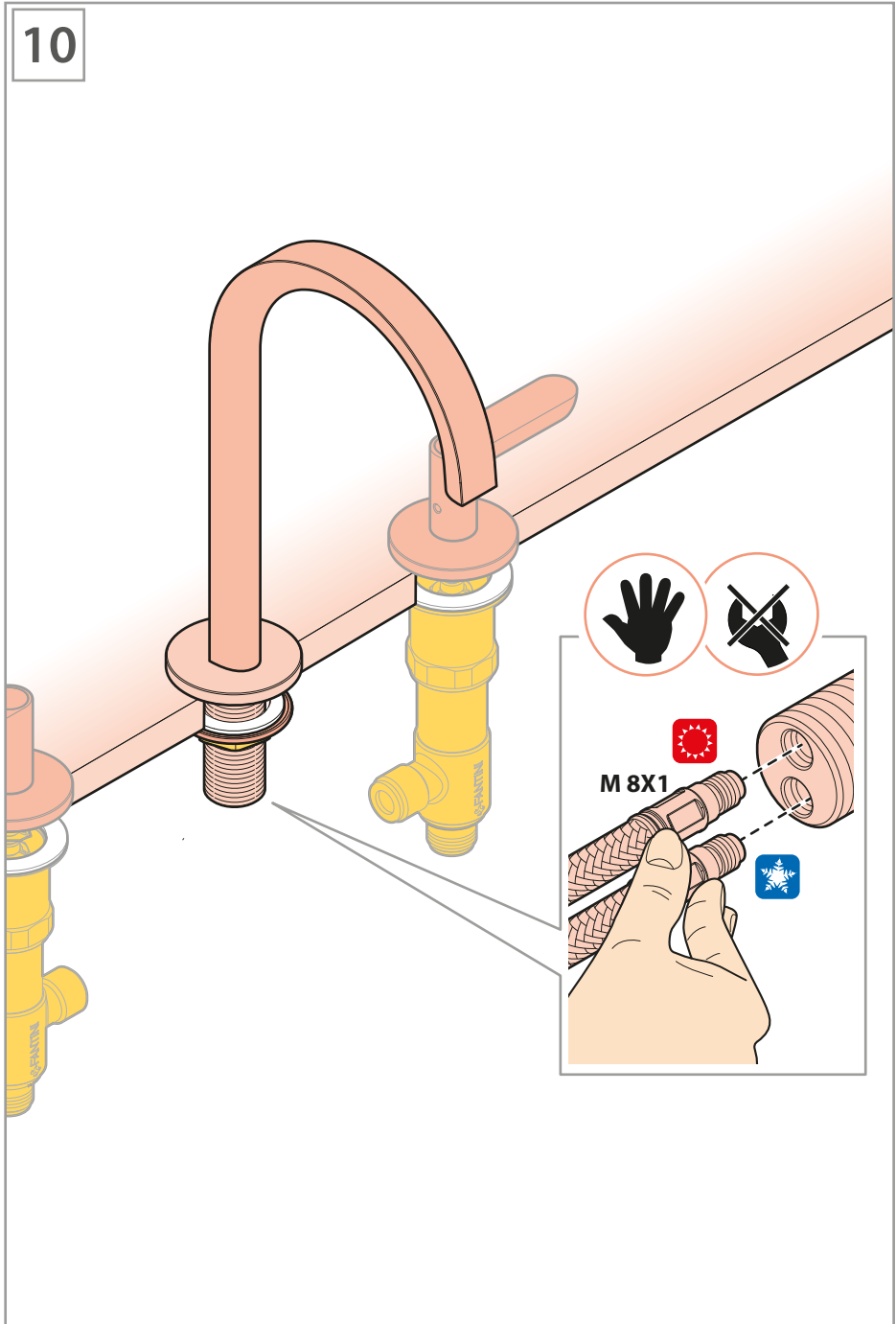



11

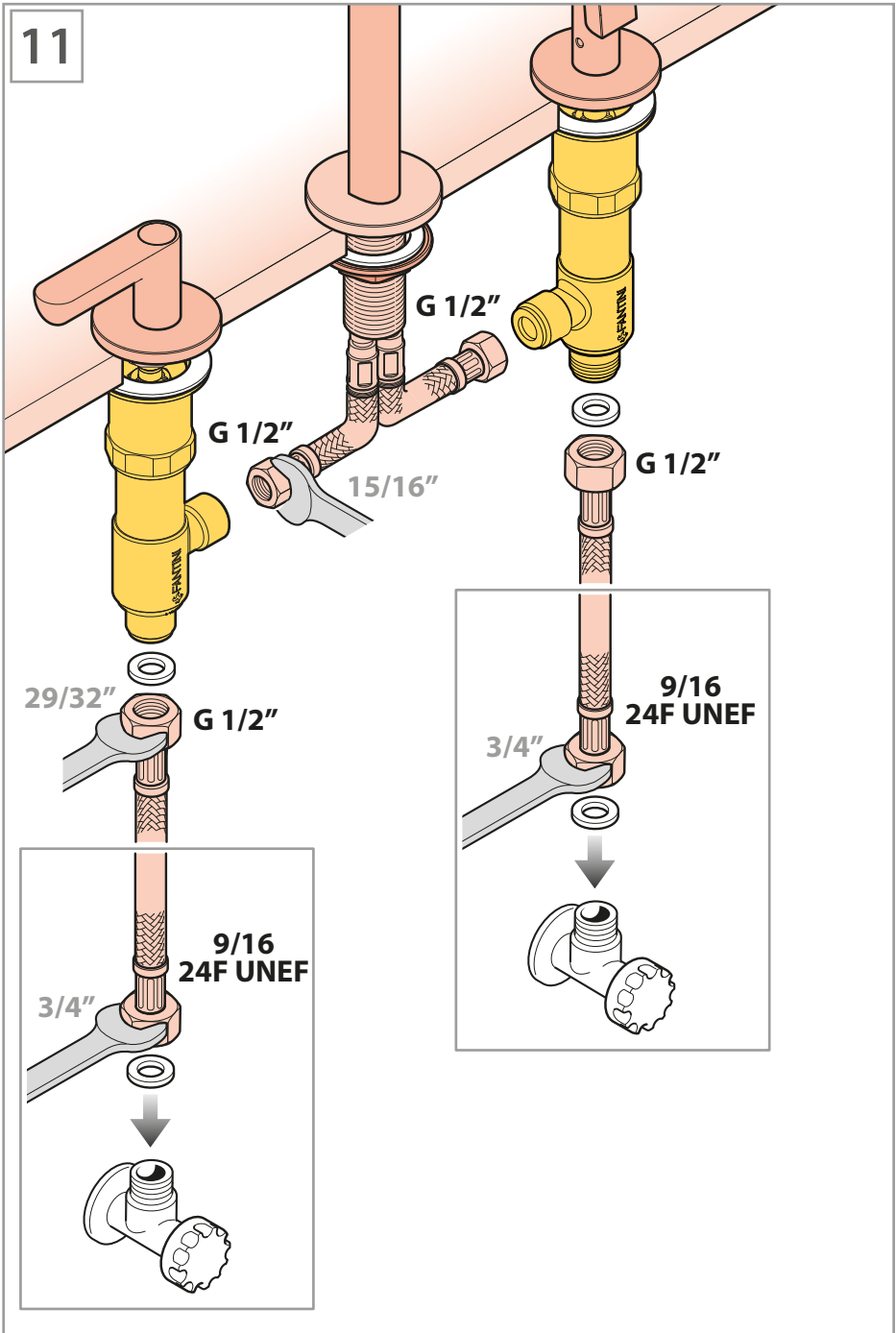

12

ICONA DECO R104U - R104WU  
R106U - R106WU

DECO  
R104U - R104WU  
R106U - R106WU

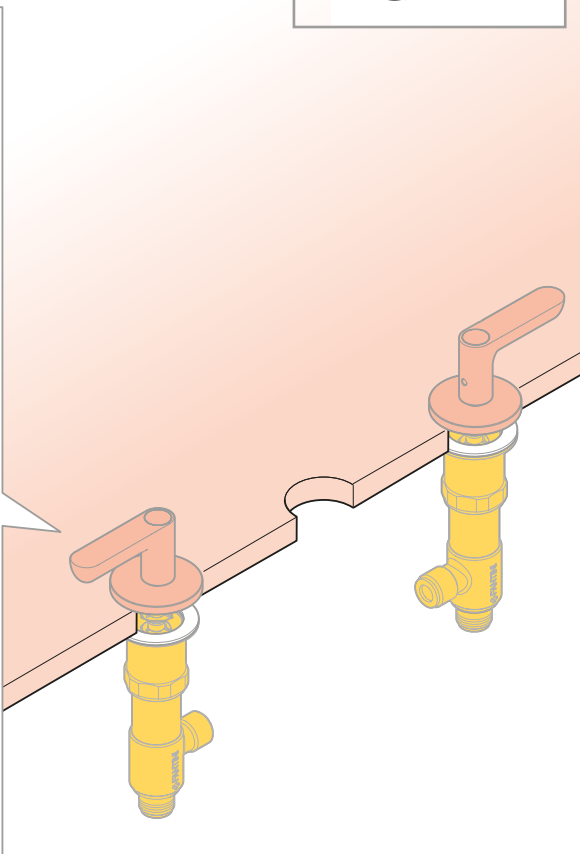
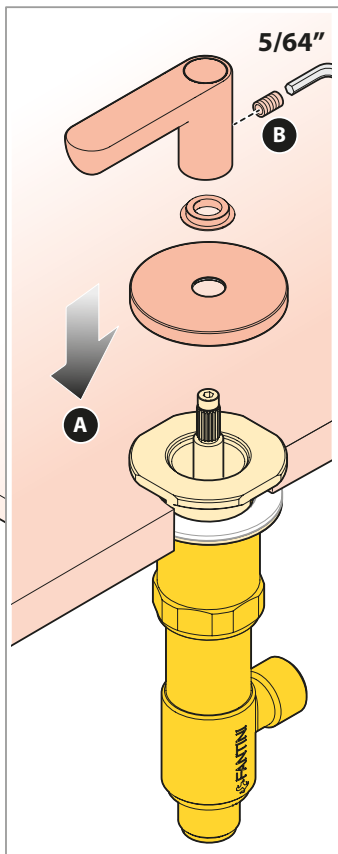
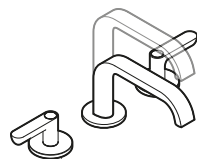



13

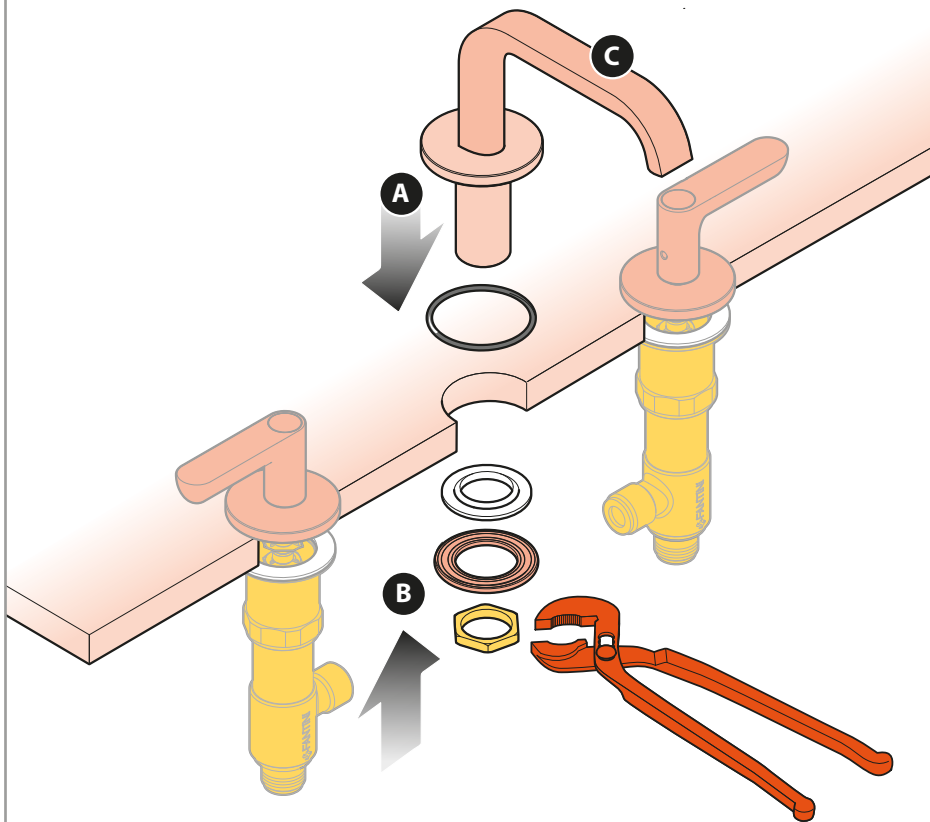

14

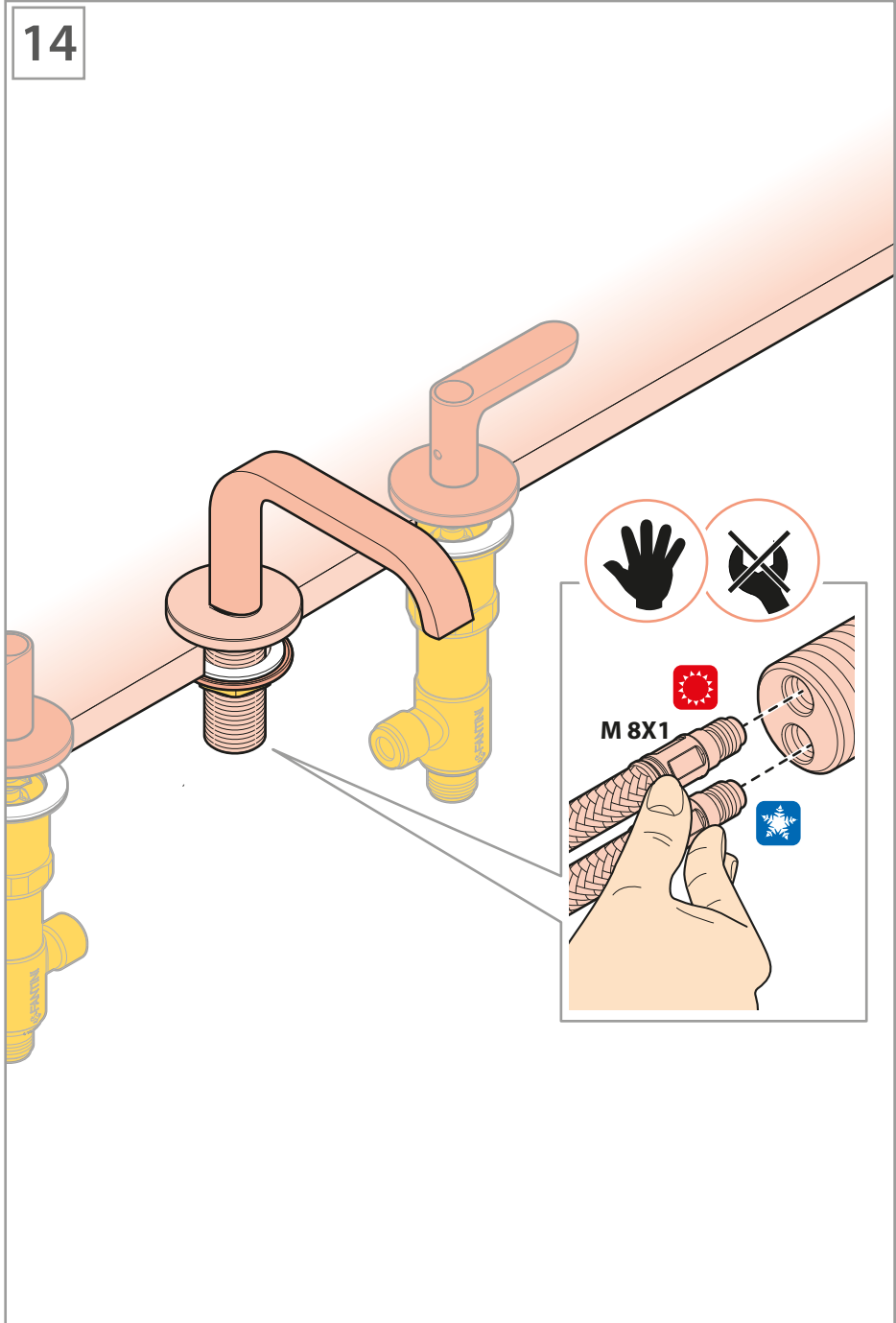



15

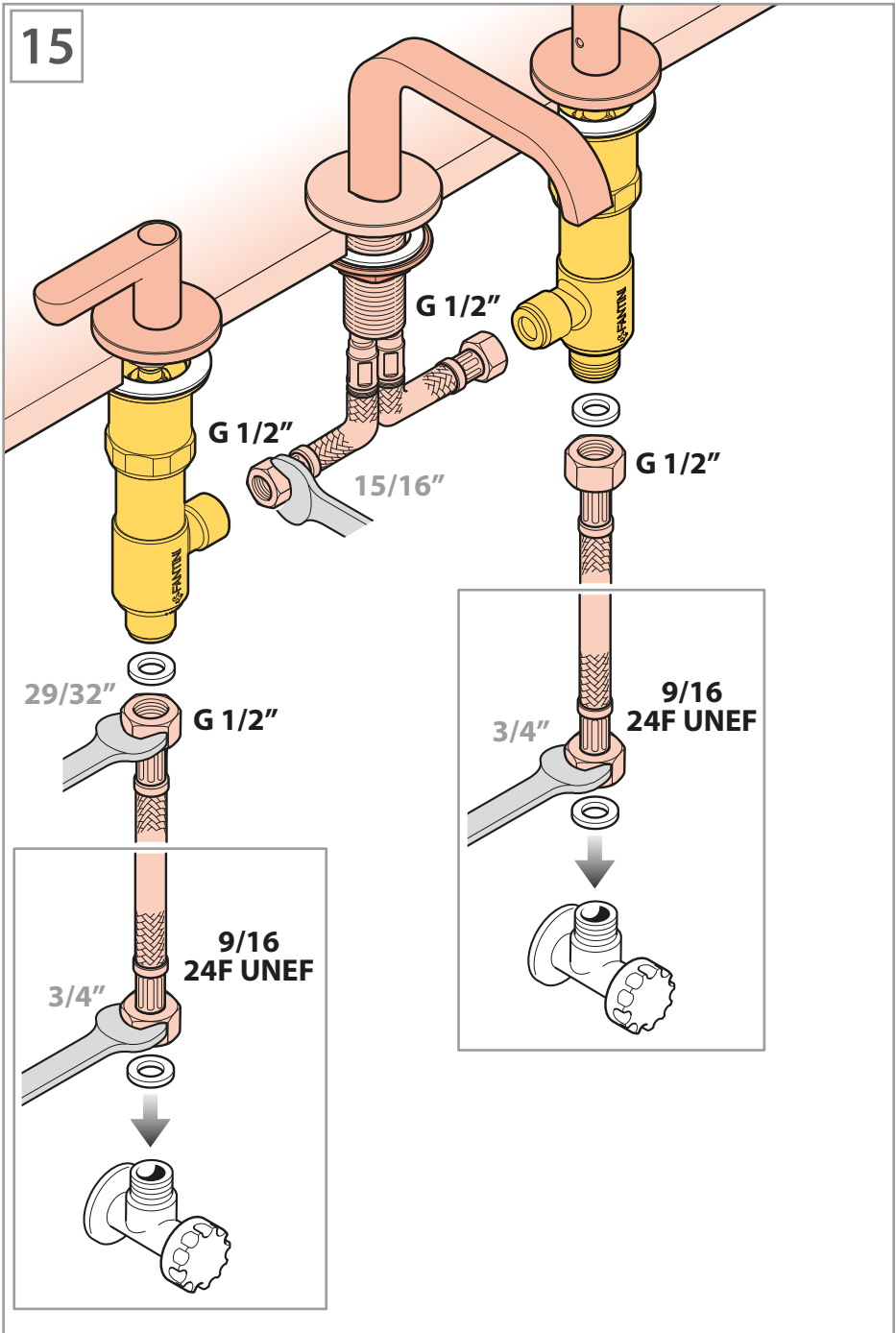

**EN** On first use or following prolonged periods of inactivity, do not use the first half-litre of drinking water dispensed. Shut off the plumbing system in the event of a long absence.

Check the water-tightness regularly.

**FR** Lors de la première utilisation ou après une longue période de non utilisation, ne pas consommer le premier demi-litre d'eau potable qui sort du robinet. Fermer l'installation hydraulique en cas d'absence prolongée. Contrôler périodiquement l'étanchéité.

**ES** Durante el primer uso o tras un largo periodo de inactividad, no consumir el primer medio litro de agua potable que salga del grifo. Cerrar la instalación de agua si va a estar ausente durante un largo periodo. Comprobar periódicamente que no haya pérdidas.



**EN**

Clean the surfaces using a soft cloth soaked in liquid soap diluted in water, then rinse and dry thoroughly.

Never use detergents containing abrasive substances or containing muriatic acid, vinegar, ammonia, acetone, bleach, domestic acids, disinfectants in general or abrasive sponges.

CAUTION! The use of products other than those recommended may damage the surfaces irreparably, in which case the manufacturer will not be held liable.

If the flow rate decreases, clean or replace the aerator.

**FR**

Nettoyer les surfaces avec un chiffon doux imbibé de savon liquide dilué dans l'eau : à la fin, rincer et essuyer avec soin.

Ne jamais utiliser de détergents contenant des substances abrasives ou à base d'acide chlorhydrique, vinaigre, ammoniac, acétone, eau de javel, acides à usage domestique, désinfectants divers, ni d'éponges abrasives.

ATTENTION ! L'emploi de produits non conseillés peut détériorer irrémédiablement la surface des articles pour lesquels le fabricant ne sera pas responsable.

Au cas où la sortie d'eau diminuerait, nettoyer ou remplacer l'aérateur.

**ES**

Las superficies deben limpiarse con un paño suave y jabón líquido diluido en agua: al finalizar, aclarar y secar con cuidado.

No utilizar en ningún caso detergentes que contengan sustancias abrasivas o a base de ácido clorhídrico, vinagre, amoníaco, acetona, lejía, ácidos de uso doméstico, desinfectantes varios o esponjas abrasivas.

¡ATENCIÓN! El uso de productos no recomendados puede ocasionar un deterioro irreparable de las superficies, en cuyo caso el fabricante no se responsabilizará de los daños.

Si disminuye el caudal de agua suministrado, limpiar o cambiar el aireador.









**Fratelli Fantini SpA**

via Buonarroti, 4  
Pella (NO) Italia  
T +39 0322 918411 r.a.  
F +39 0322 969530  
fantini@fantini.it  
www.fantini.it

