

# ABOUTWATER

Instructions / Instructions De Montage / Instrucciones

## AW/PIPE

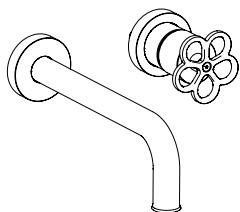

ART. T513BU

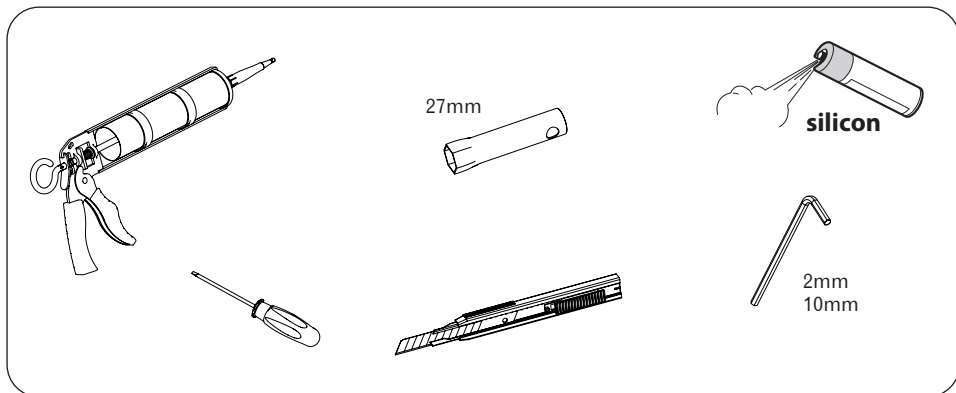

TECHNICAL DETAILS - DONNÉES TECHNIQUES - DATOS TÉCNICOS - DADOS TÉCNICOS

EN

FR

ES

Minimum pressure	Pression minimum	Pression mínima	1 BAR
Minimum pressure	Pression maximum	Pression máxima	10 BAR
Recommened working pressure	Pression optimale de service	Pression de trab. aconsejada	2-5 BAR
Max. water temperature	Température maximum	Temperatura máxima	80° C - 176° F
Maximum water temperature reccomended	Température maximum optimale	Temperatura máxima aconsejada	65° C - 149° F
Maximum in-let pressure difference (hot - cold)	Différence max. de pression d'arrivée (chaud - froid)	Diferencial max. de presiùn de entrada (caliente - fria)	1.5 BAR

EN

If water pressure is above 5 bar, it is advisable to install a flow restrictor upstream of the water supply to avoid vibrations and regulate temperature.

FR

Si la pression de l'eau est supérieure à 5 bar, il est recommandé d'installer un réducteur de pression en amont de l'alimentation afin d'éviter toute vibration et régulariser le réglage de la température.

ES

Si la presión del agua supera los 5 bar, es preferible instalar un limitador de caudal en la conducción de la alimentación para evitar vibraciones y normalizar la regulación de la temperatura.

EN

**Advice on product care**

To clean the surface use a soap and water solution. Never use for any reason cleaning solutions containing abrasive substances, chloric acids, ammonia, vinegar, bleach, domestic acids, disinfectants, or anytype of abrasive pad. WARNING! Incorrect cleaning may permanently ruin the surface of the products and in such case the manufacturer may not be held liable for damage. The Manufacturer reserves the right to modify product and accessories at any time without prior notice. Datas, products and sketches included in this document are just for information and do not bind the producer.

FR

**Conseils pour l'entretien du produit**

La poussiere en surface devra être faite en utilisant un savon liquide dilué dans l'eau. Ne jamais utiliser en aucun cas des détergents liquides contenant des substances abrasives ou à base d'acide, nid'éponges abrasives, vinaigre, ammoniacque, acétone, eau de Javel, acides à usage domestique, désinfectants divers. ATTENTION! L'emploi de produits non conseillés peut détériorer irrémédiablement la surface des articles pour lesquels le fabricant ne sera pas responsable. La société se réserve le droit de modifier ses produits et ses accessoires à tout moment et sans préavis. Informations, produits et croquis reproduits dans ce documents sont de nature informative et ne sont pas contractuels.

ES

**Consejos para el cuidado del producto**

La limpieza de las superficies se hace utilizando un jabón líquido diluido en agua. No usar en ningún caso detergentes líquidos que contengan sustancias abrasivas ó a base de ácido clorhídrico, estropajossabrasivos, amoniaco, acetona, lejía, ácidos de uso doméstico, desinfectantes varios. ATENCIÓN! El uso de productos desaconsejados puede danar irremediamente las superficies de los elementos, de lo cual el fabricante no se hará responsable en ningún caso. La sociedad se reserva el derecho de modificar sus productos y accesorios en cualquier momento y sin previo aviso.

**T513BU - M011AU**

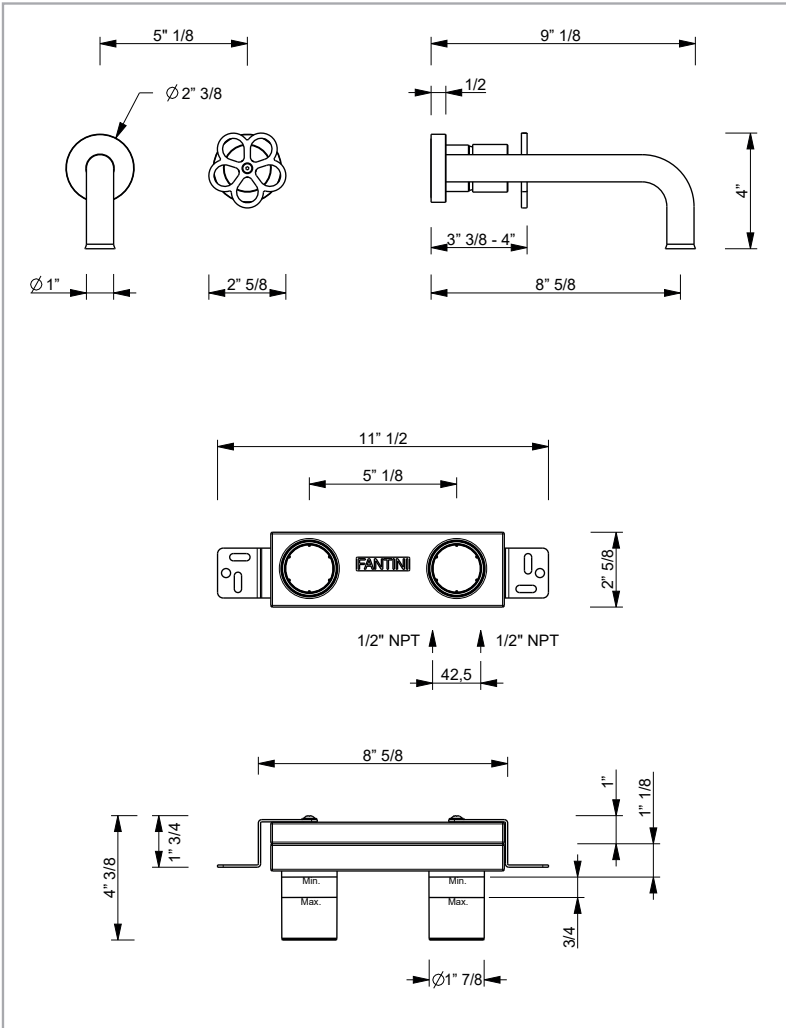

- EN** These mixers can be used with high-pressure hot water accumulators or with instant water heaters.
- FR** Ces mitigeurs peuvent être utilisés avec des accumulateurs d'eau chaude à pression ou avec des chauffe-eau instantanés.
- ES** Estos monomandos pueden utilizarse con acumuladores de agua caliente a presión o con calentadores instantáneos.



- EN** For installations within the Min and Max limits indicated by the label applied to the product, see from page 7. In the case of installations beyond the Max limit indicated by the label applied on the product where the kit is needed extension, see from page 5.
- FR** Pour les installations dans les limites Min et Max indiquées par l'étiquette apposée sur le produit, voir à partir de la page 7. Dans le cas d'installations au-delà de la limite Max indiquée par l'étiquette apposée sur le produit où le kit est nécessaire rallonge, voir à partir de la page 5.
- ES** Para instalaciones dentro de los límites Mín. Y Máx. Indicados por la etiqueta aplicada al producto, consulte a partir de la página 7. En el caso de instalaciones más allá del límite Max indicado por la etiqueta aplicada en el producto donde se necesita el kit extensión, ver a partir de la página 5.
- PT** Para instalações dentro dos limites mínimo e máximo indicados pela etiqueta aplicada ao produto, consulte a página 7. No caso de instalações além do limite máximo indicado pela etiqueta aplicada no produto onde o kit é necessário extensão, veja na página 5.

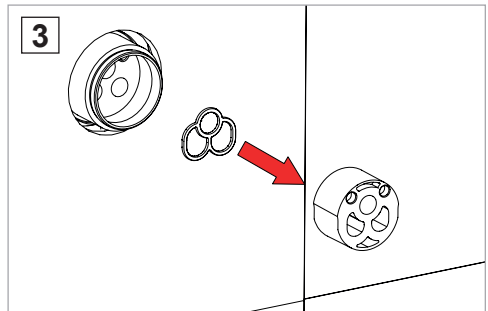
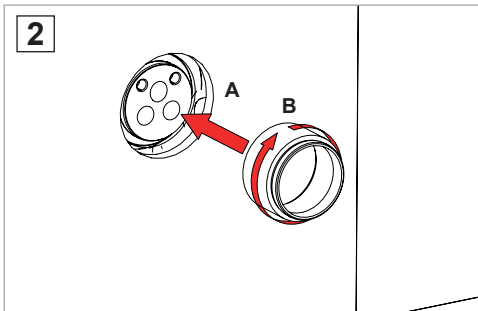
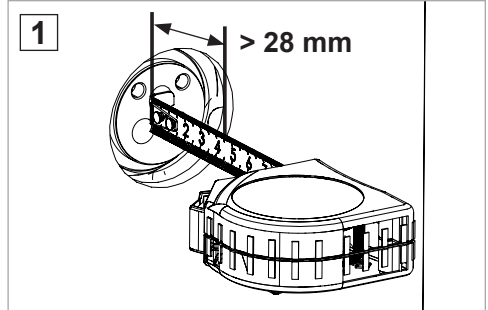
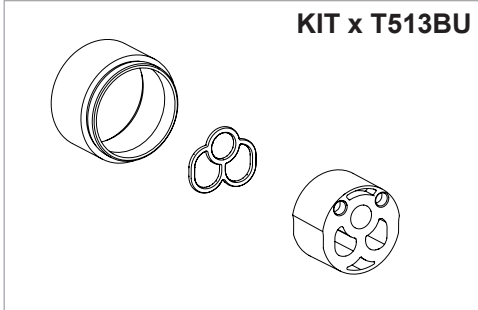

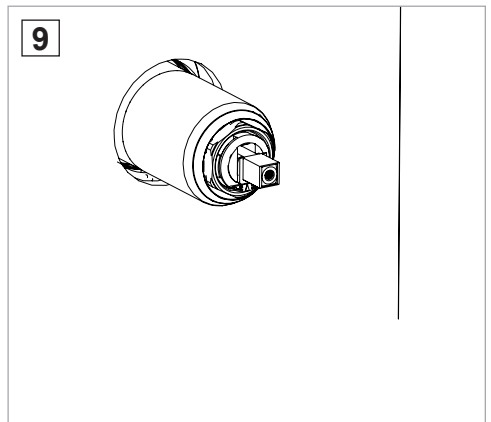
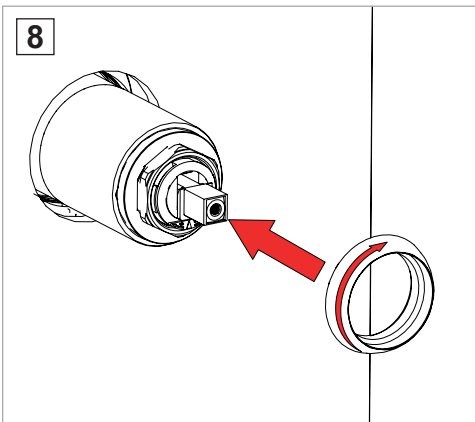
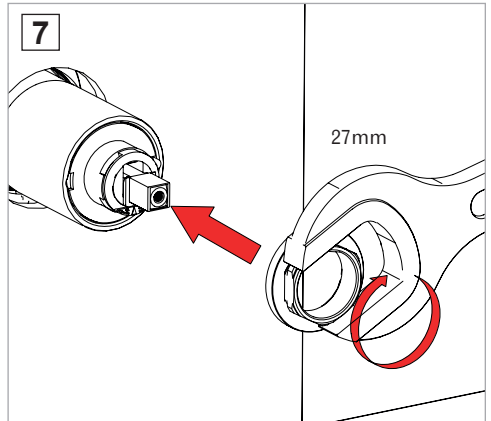
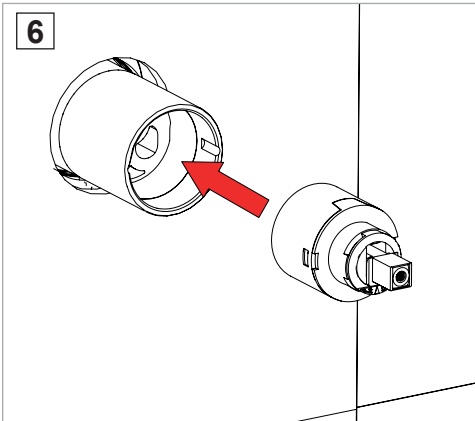
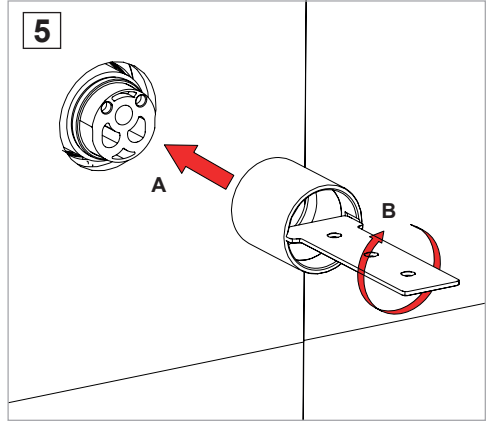
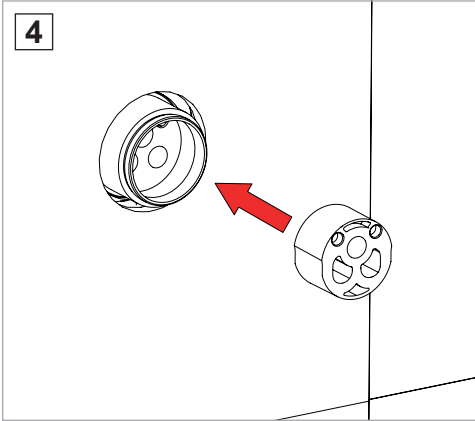

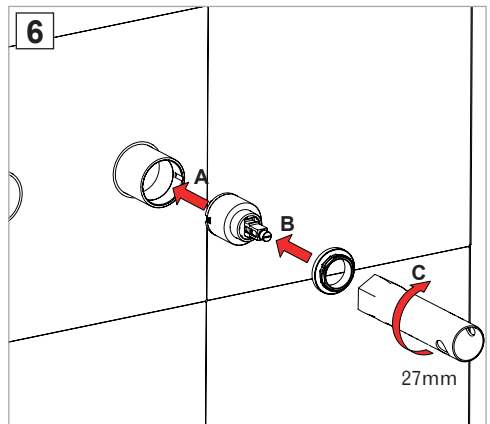
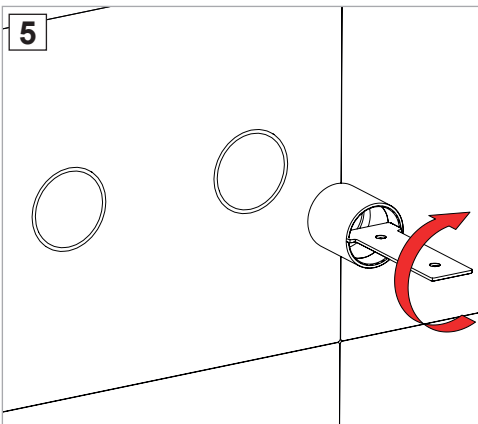
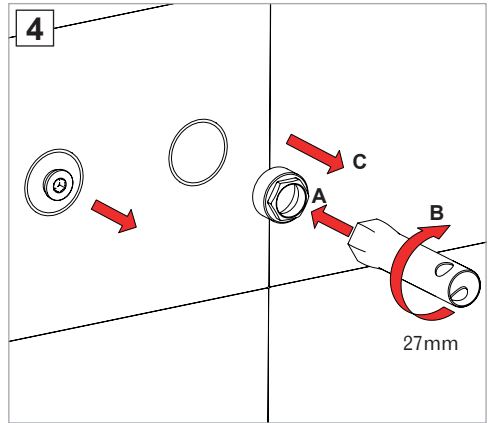
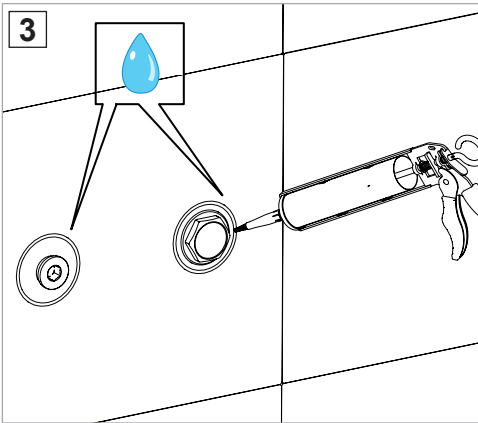
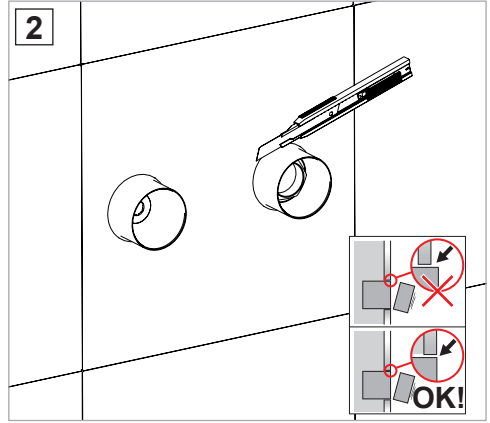
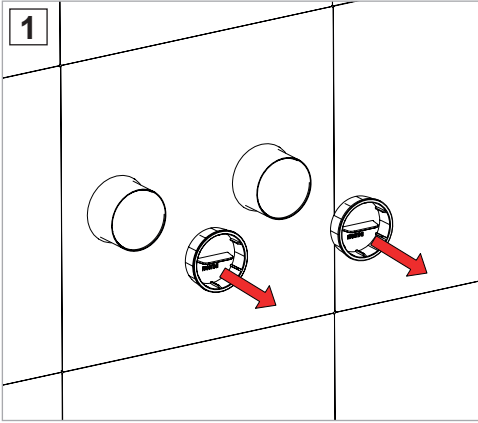

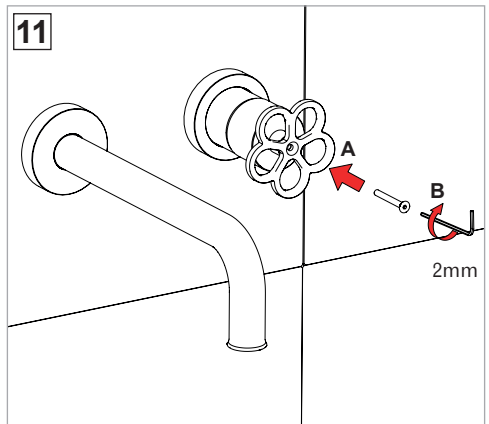
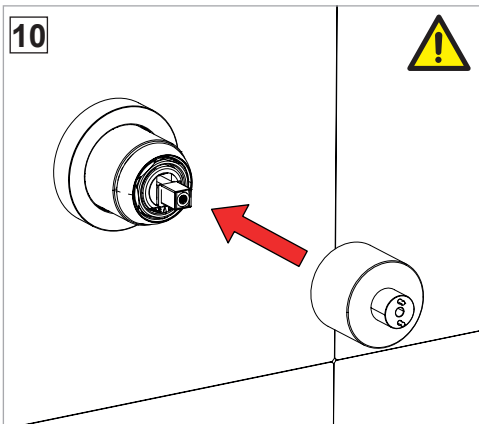
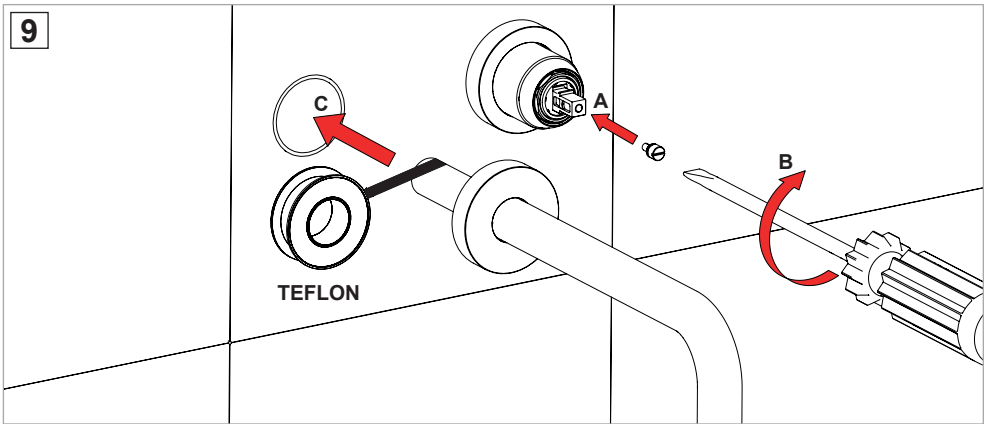
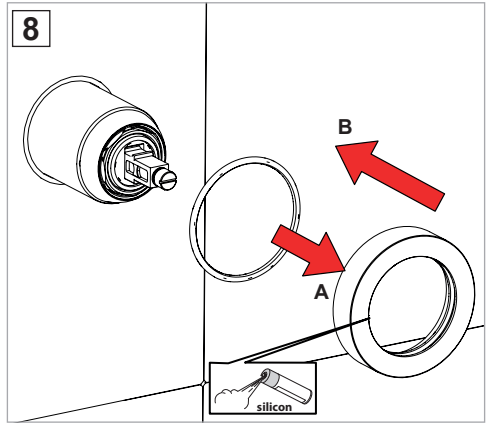
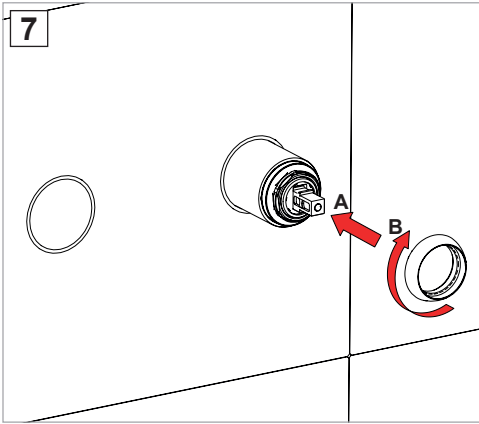



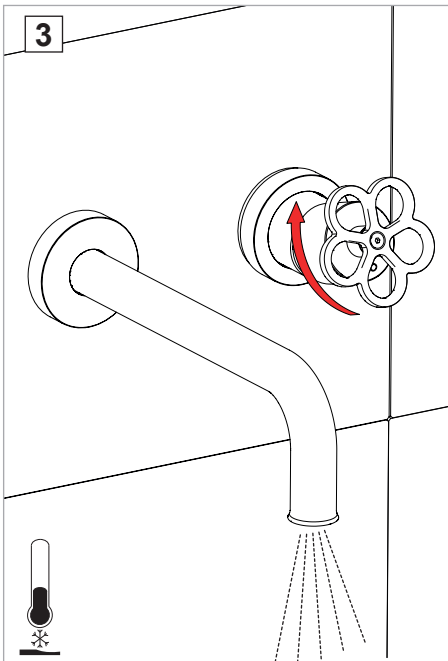
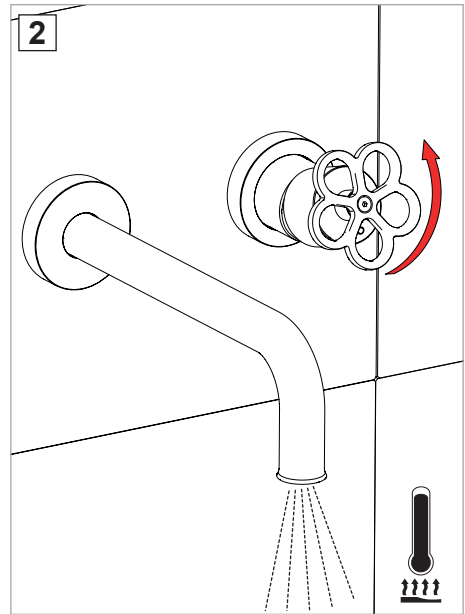
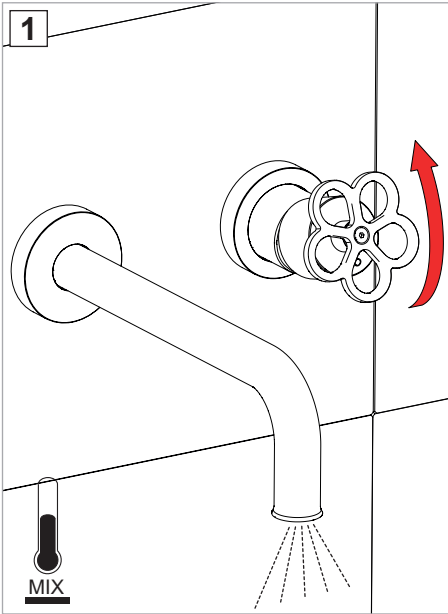

**EN**

On first use or following prolonged periods of inactivity, do not use the first half-litre of drinking water dispensed. Shut off the plumbing system in the event of a long absence. Check the water-tightness regularly.

**FR**

Lors de la première utilisation ou après une longue période de non utilisation, ne pas consommer le premier demi-litre d'eau potable qui sort du robinet. Fermer l'installation hydraulique en cas d'absence prolongée. Contrôler périodiquement l'étanchéité.

**ES**

Durante el primer uso o tras un largo periodo de inactividad, no consumir el primer medio litro de agua potable que salga del grifo. Cerrar la instalación de agua si va a estar ausente durante un largo periodo. Comprobar periódicamente que no haya pérdidas.

**PT**

Na primeira utilização ou após um longo período de inutilização, não consuma o primeiro meio litro de água potável distribuída. Feche o circuito hidráulico no caso de ausência prolongada. Verifique periodicamente a vedação.

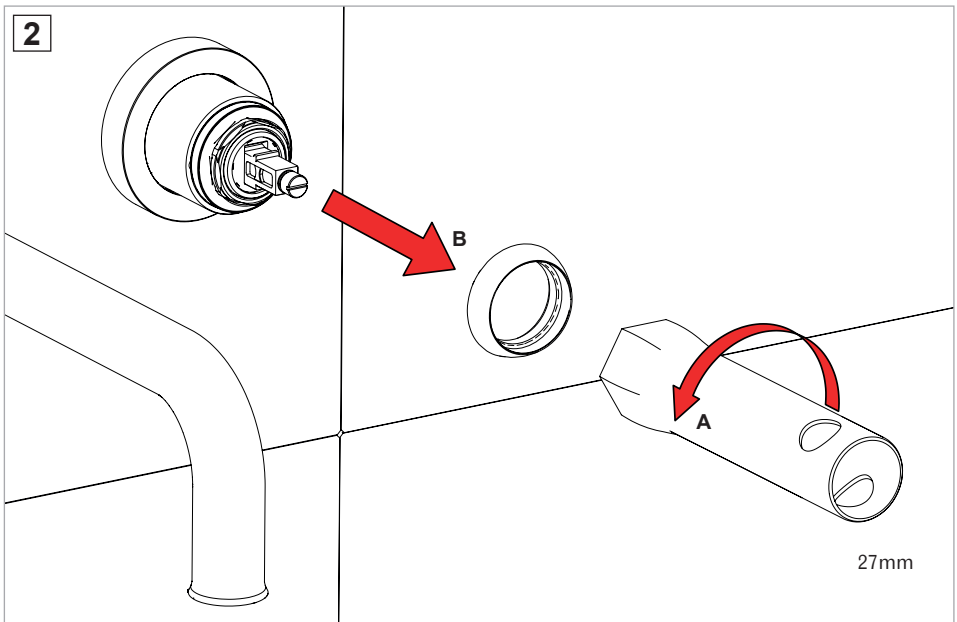
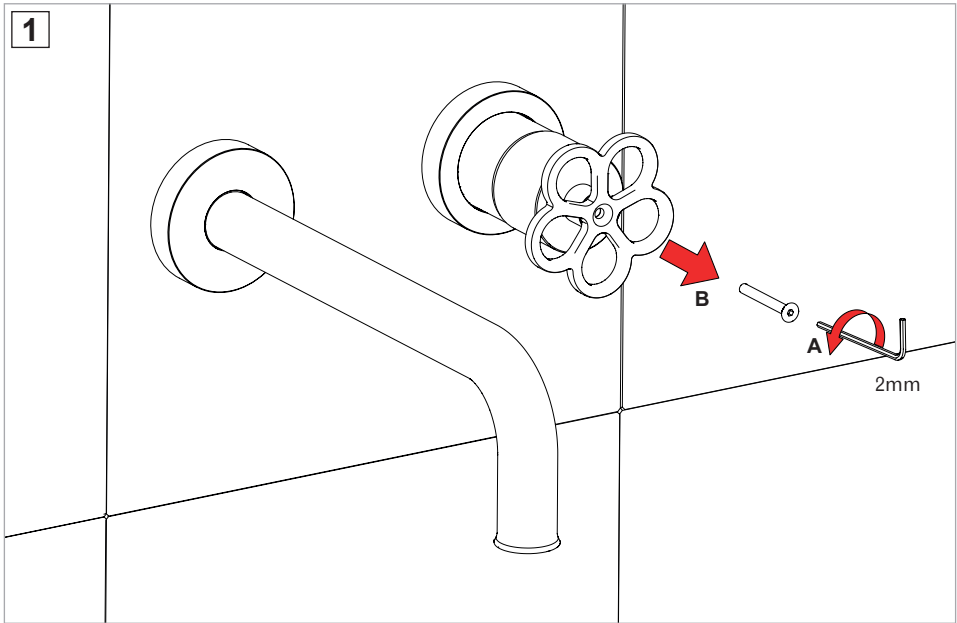
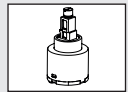

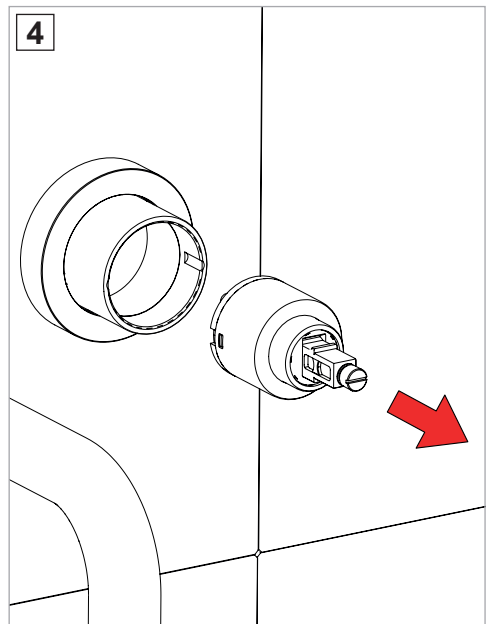
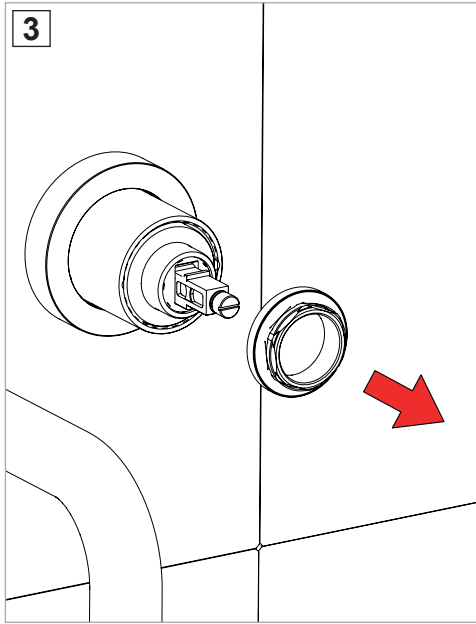
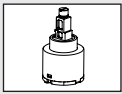

- Replace following the instructions in reverse order (5-4-3-2-1).
- Re-installer au contraire du procédé (5-4-3-2-1).
- Colocar según el procedimiento inverso (5-4-3-2-1).

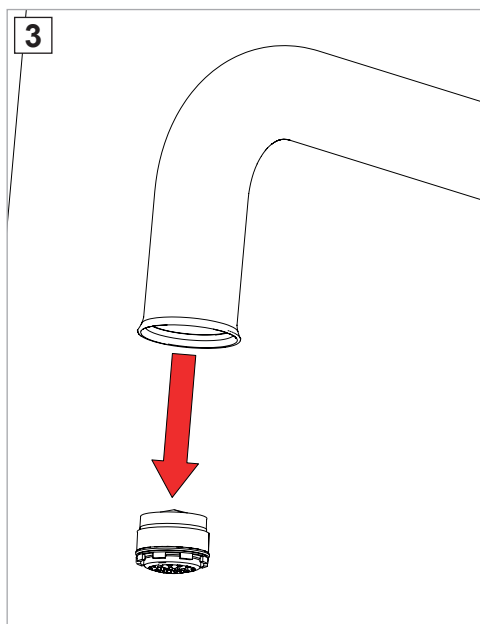
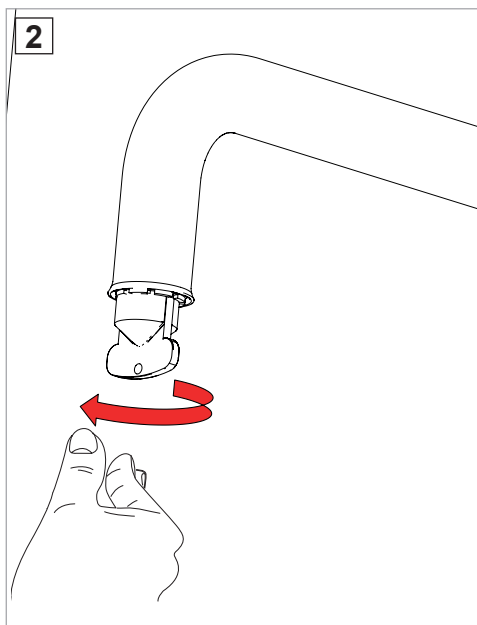
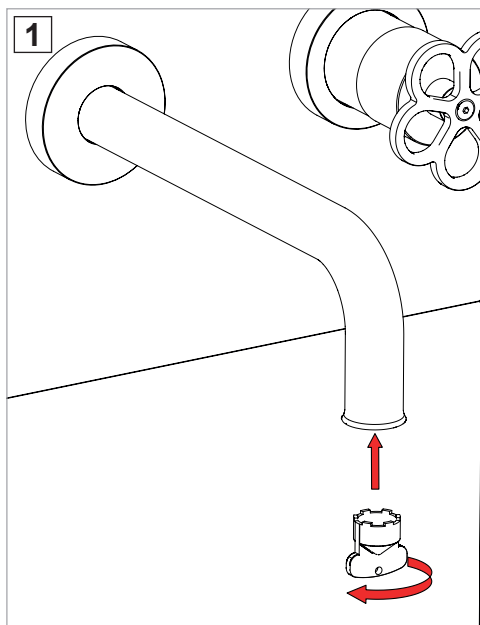

- Replace following the instructions in reverse order.
- Re-installer au contraire du procédé.
- Colocar según el procedimiento inverso.

Notes / Notes / Notas

.....

.....

.....

.....

.....

.....

.....

.....

.....

.....

.....

.....

.....

.....

.....

.....

.....

.....

.....

.....

.....

.....

.....

.....

.....

.....

.....

.....

.....

.....

.....

.....

.....

.....

.....

.....

.....

.....

.....

.....

.....

.....

.....

.....

.....

A series of horizontal dotted lines for writing notes, spanning the width of the page.

# ABOUTWATER

112000006000000U Rev. 0



# ABOUTWATER

Boffi FANTINI

**Fratelli Fantini SpA**

via Buonarroti, 4

28010 Pella (NO) Italia

T +39 0322 918411 r.a.

F +39 0322 969530

[www.aboutwater.it](http://www.aboutwater.it)

[www.fantini.it](http://www.fantini.it)

[fantini@fantini.it](mailto:fantini@fantini.it)