

ABOUTWATER AC/ECLIPSE

Instructions / Instructions De Montage / Instrucciones

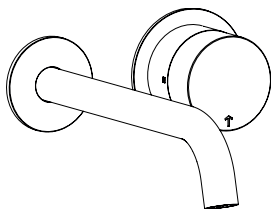

ART. L513BU

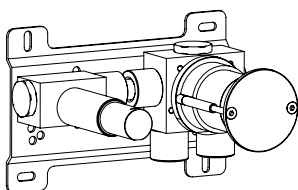

ART. D711AU

NECESSARY TOOLS - OUTILS NÉCESSAIRES - HERRAMIENTAS NECESARIAS

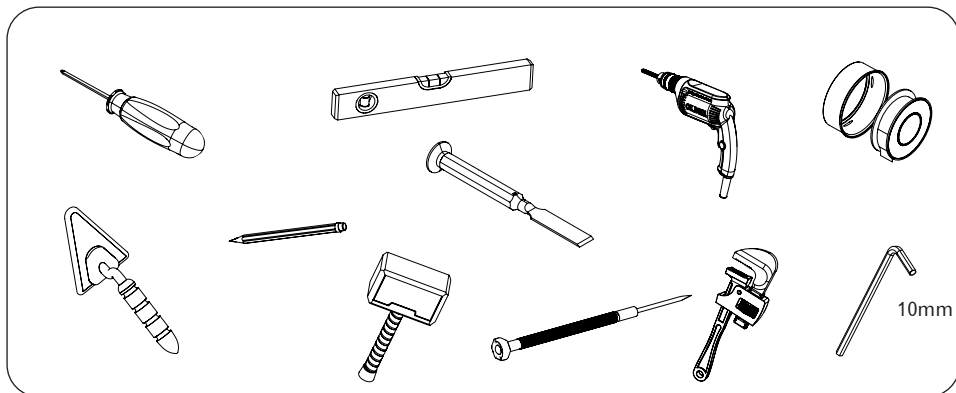

TECHNICAL DETAILS - DONNÉES TECHNIQUES - DATOS TÉCNICOS

EN	FR	ES	
Minimum pressure	Pression minimum	Pression mínima	1 BAR
Minimum pressure	Pression maximum	Pression máxima	10 BAR
Reccomended working pressure	Pression optimale de service	Pression de trab. aconsejada	2-5 BAR
Max. water temperature	Température maximum	Temperatura máxima	80° C - 176° F
Maximum water temperature reccomended	Température maximum optimale	Temperatura máxima aconsejada	65° C - 149° F
Maximum in-let pressure difference (hot - cold)	Différence max. de pression d'arrivée (chaud - froid)	Diferencial max. de presión de entrada (caliente - fria)	1.5 BAR

- EN** If water pressure is above 5 bar, it is advisable to install a flow restrictor upstream of the water supply to avoid vibrations and regulate temperature.
- FR** Si la pression de l'eau est supérieure à 5 bar, il est recommandé d'installer un réducteur de pression en amont de l'alimentation afin d'éviter toute vibration et régulariser le réglage de la température.
- ES** Si la presión del agua supera los 5 bar, es preferible instalar un limitador de caudal en la conducción de la alimentación para evitar vibraciones y normalizar la regulación de la temperatura.

EN Advice on product care

To clean the surface use a soap and water solution. Never use for any reason cleaning solutions containing abrasive substances, chloric acids, ammonia, vinegar, bleach, domestic acids, disinfectants, or anytype of abrasive pad. **WARNING!** Incorrect cleaning may permanently ruin the surface of the products and in such case the manufacturer may not be held liable for damage. The Manufacturer reserves the right to modify product and accessories at any time without prior notice. Datas, products and sketches included in this document are just for information and do not bind the producer.

FR Conseils pour l'entretien du produit

La poussiere en surface devra être faite en utilisant un savon liquide dilué dans l'eau. Ne jamais utiliser en aucun cas des détergents liquides contenant des substances abrasives ou à base d'acide, nid'éponges abrasives, vinaigre, ammoniacque, acétone, eau de Javel, acides à usage domestique, désinfectants divers. **ATTENTION!** L'emploi de produits non conseillés peut détériorer irrémédiablement la surface des articles pour lesquels le fabricant ne sera pas responsable. La société se réserve le droit de modifier ses produits et ses accessoires à tout moment et sans préavis. Informations, produits et croquis reproduits dans ce documents sont de nature informative et ne sont pas contractuels.

ES Consejos para el cuidado del producto

La limpieza de las superficies se hace utilizando un jabón liquido diluido en agua. No usar en ningún caso detergentes liquidos que contengan sustancias abrasivas ó a base de ácido clorhídrico, estropajossabrasivos, amoniaco, acetona, lejía, ácidos de uso doméstico, desinfectantes varios. **ATENCIÓN!** El uso de productos desaconsejados puede danar irremediamente las superficies de los elementos, de lo cual el fabricante no se hará responsable en ningún caso. La sociedad se reserva el derecho de modificar sus productos y accesorios en cualquier momento y sin previo aviso.

D711AU+L513BU

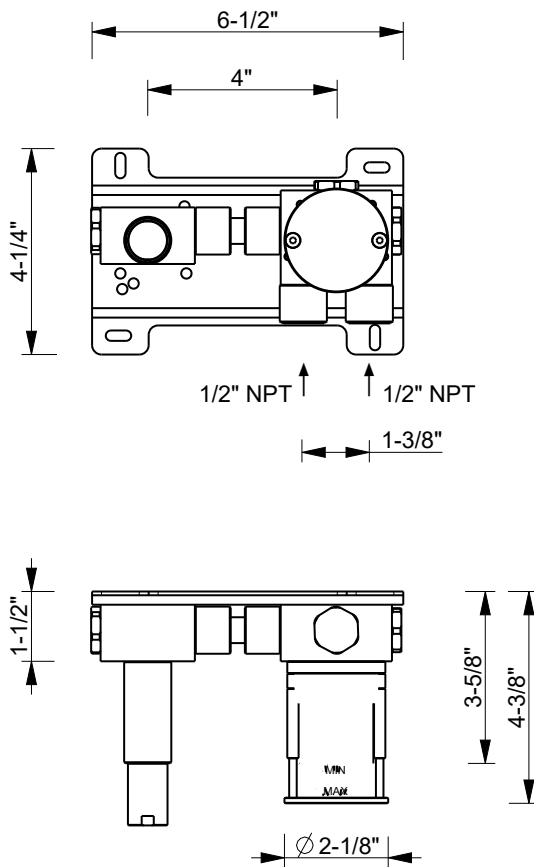

- EN** These mixers can be used with high-pressure hot water accumulators or with instant water heaters.
- FR** Ces mitigeurs peuvent être utilisés avec des accumulateurs d'eau chaude à pression ou avec des chauffe-eau instantanés.
- ES** Estos monomandos pueden utilizarse con acumuladores de agua caliente a presión o con calentadores instantáneos.

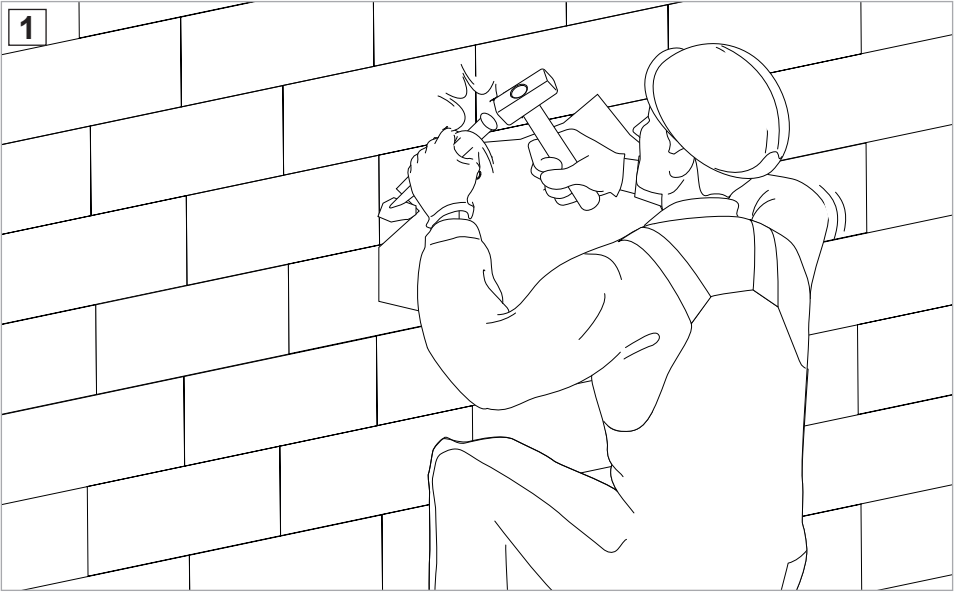

minimum depth / profondeur minimale / profundidad mínima

maximum depth / profondeur maximale / profundidad máxima

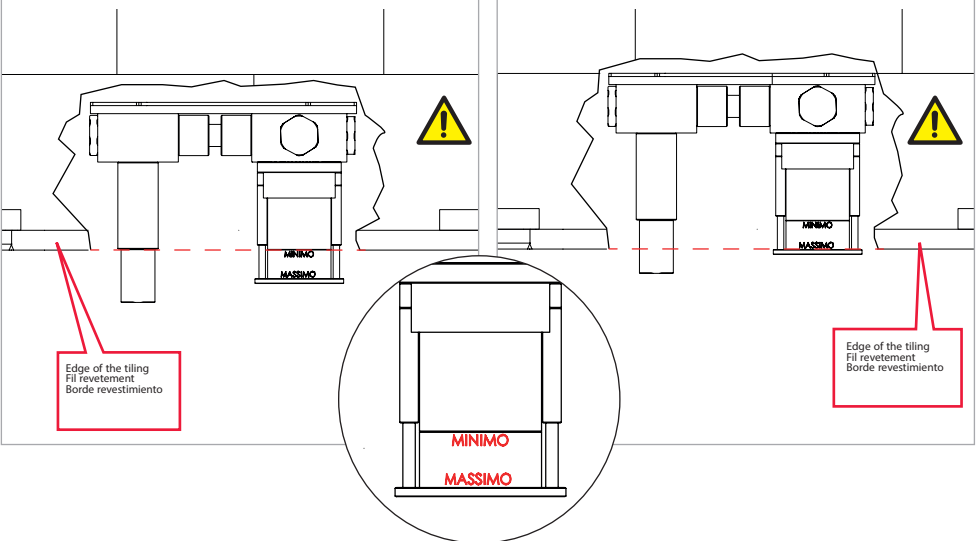

Edge of the tiling
Borde revestimiento

Edge of the tiling
Borde revestimiento

- Put the system under pressure in order to verify the hold and correct installation
- L'installation sous pression pour en vérifier l'étanchéité et le bon fonctionnement
- Presurizar la planta para comprobar su retención instalación correcta

3

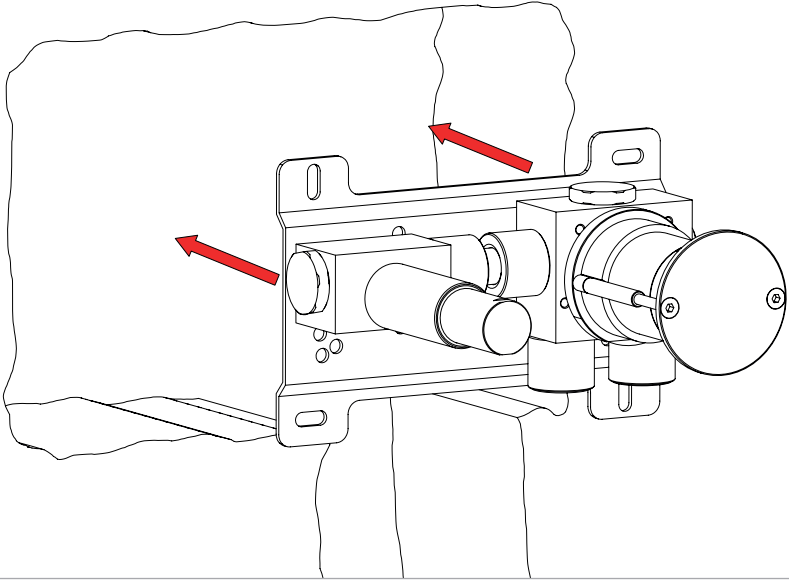

4

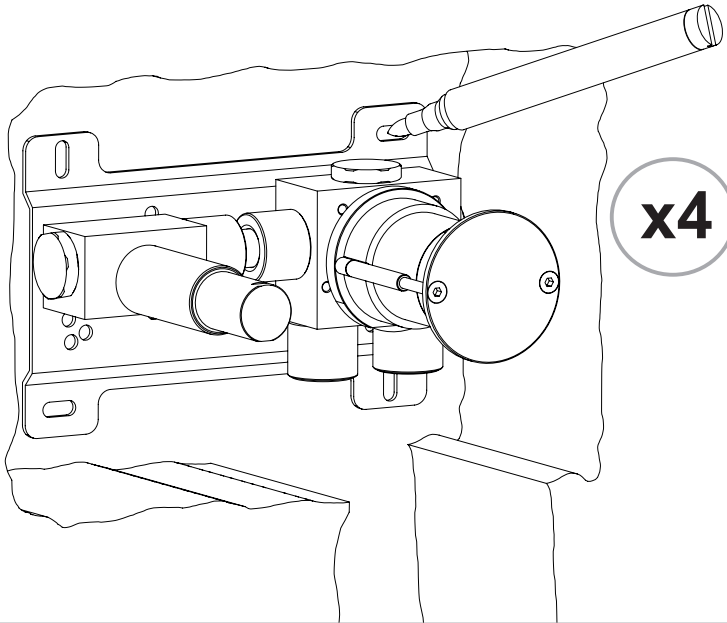

5

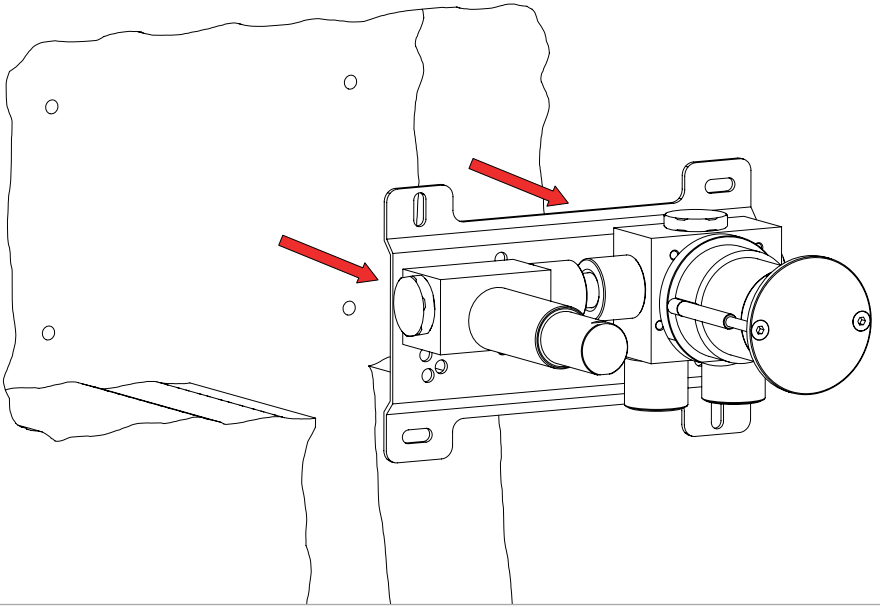

6

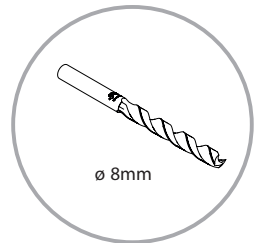
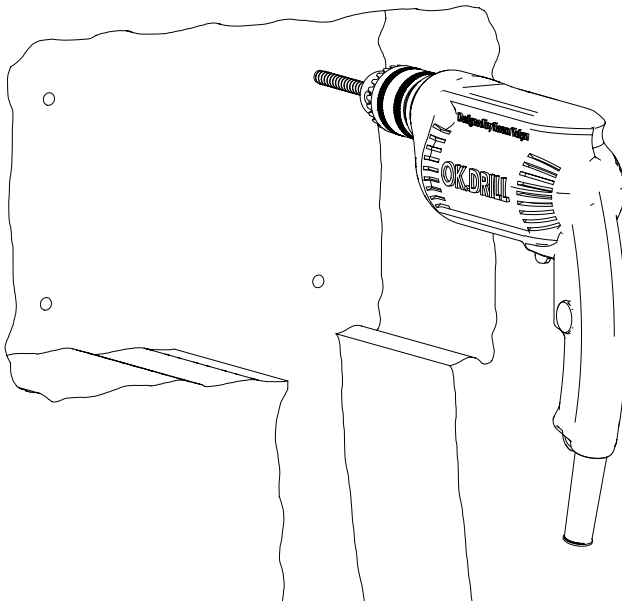

x4

7

x4

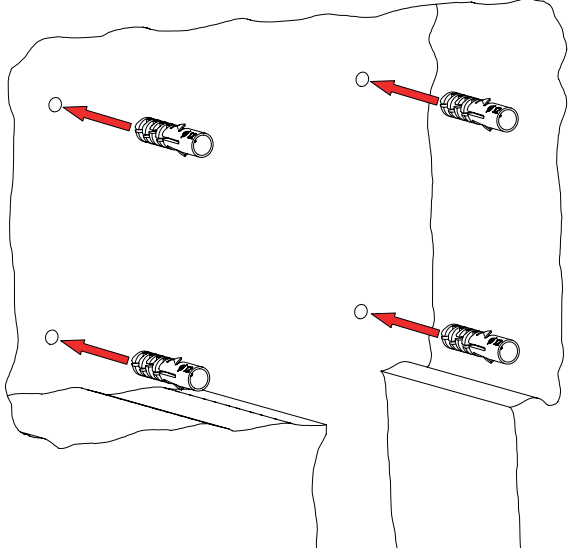

7

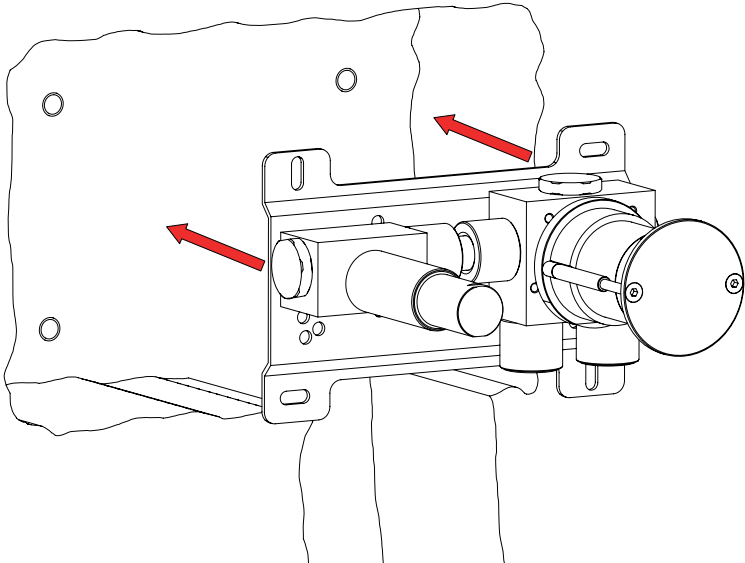

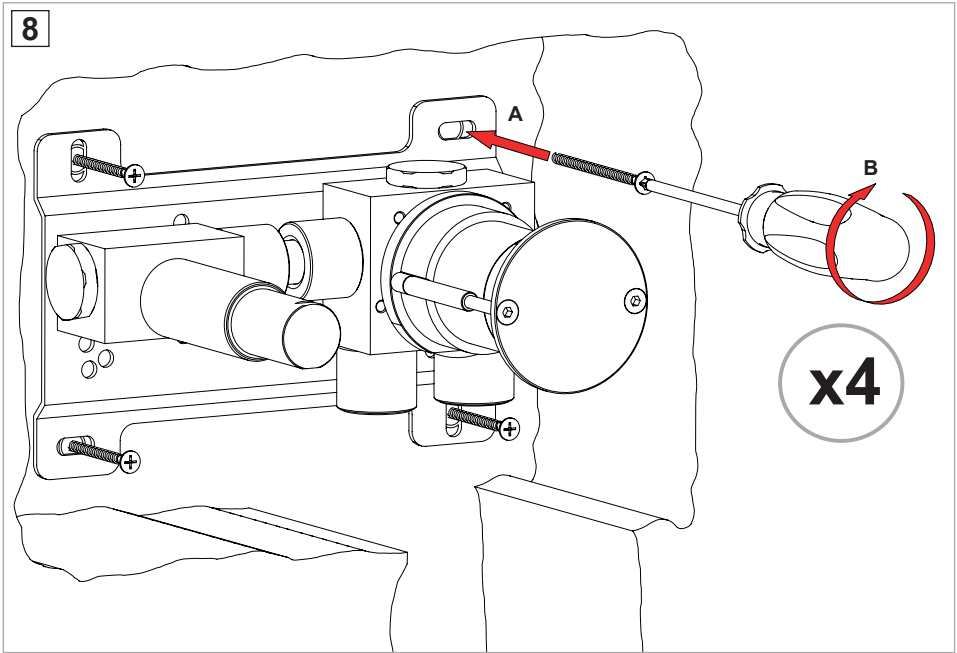

- EN** Please note, screw and dowel are NOT supplied, they must be chosen according to the support.
- FR** Nota bene, les vis et les chevilles NE sont PAS fournies, elles doivent être choisies en fonction du support.
- ES** Tenga en cuenta que los tacos y tornillos NO suministrados deben elegirse de acuerdo con el soporte.

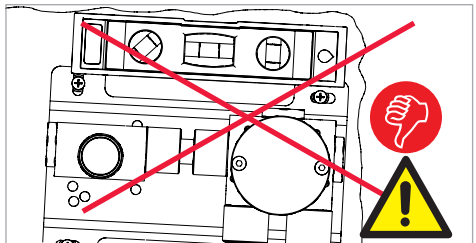
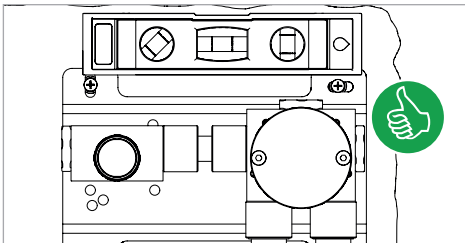
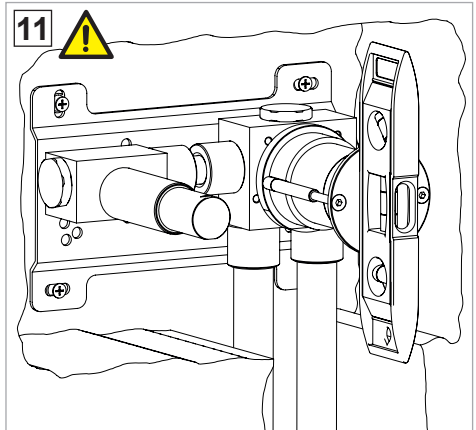
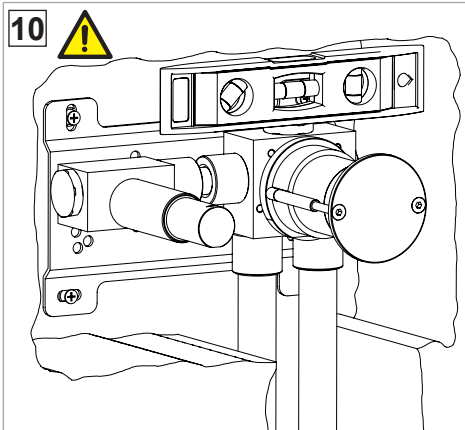
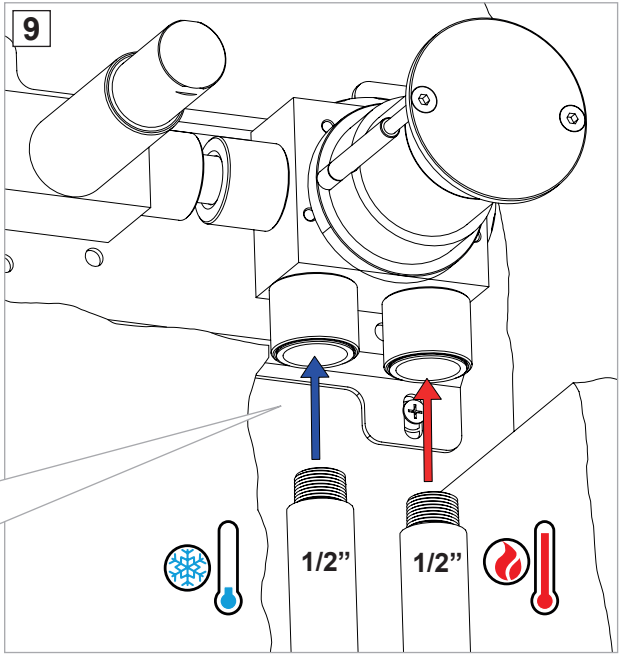
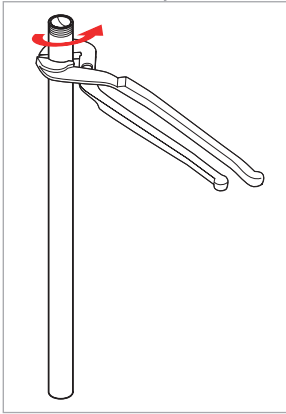
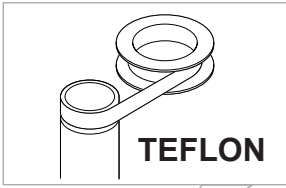

12

**INLET TEST
ESSAI ENTRÉES
PRUEBA DE LAS ENTRADAS**



**MIN 5 Bar
Max 10 Bar**

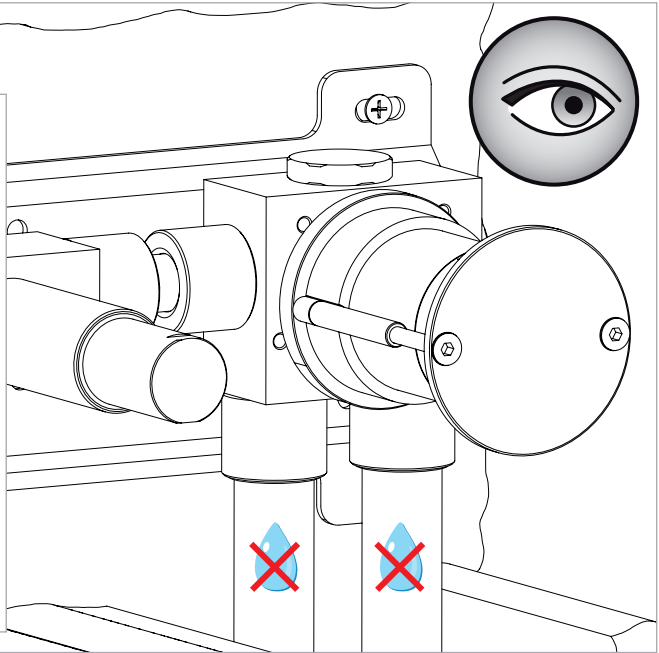

13

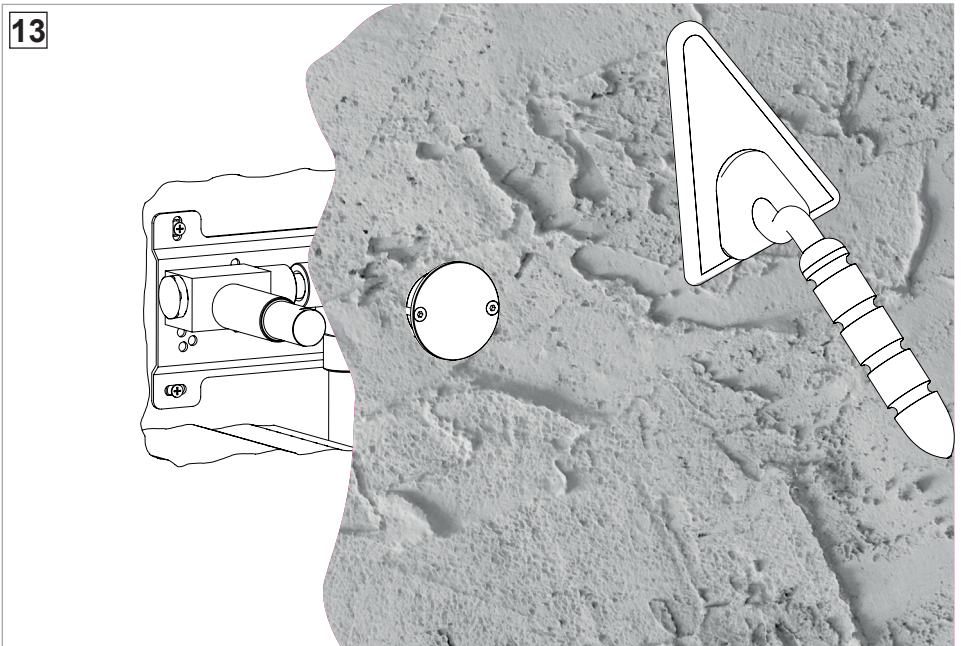

14

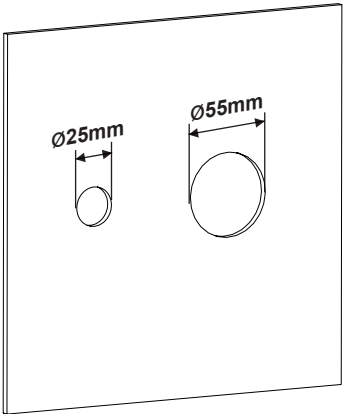

15

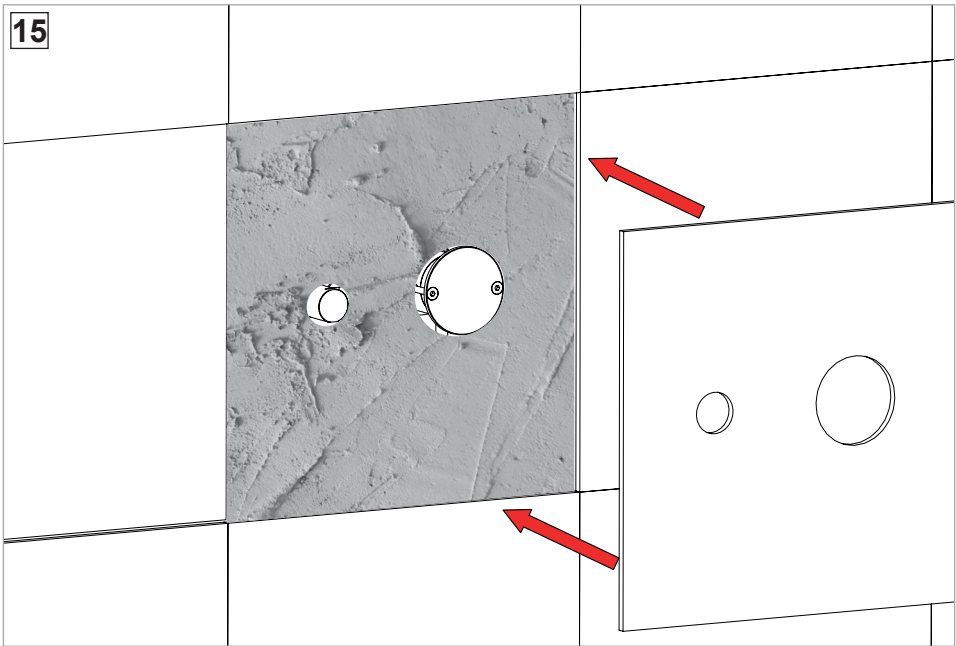

16

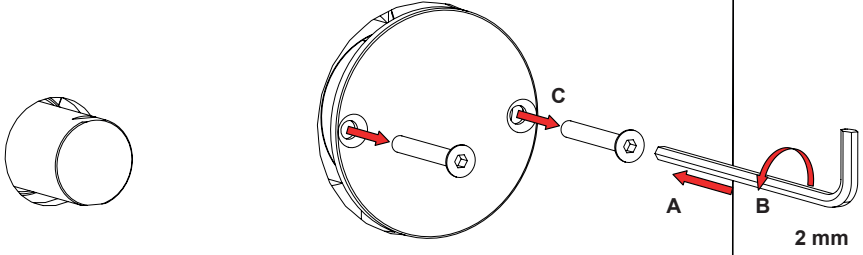

17

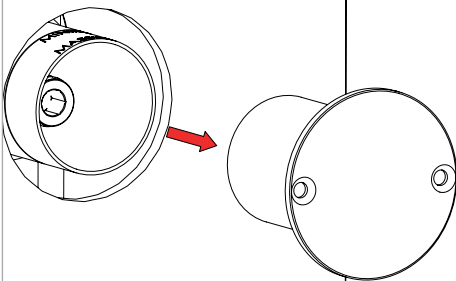

18

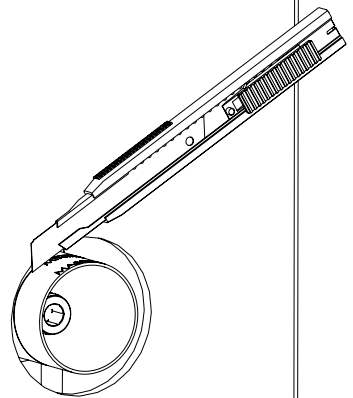

19

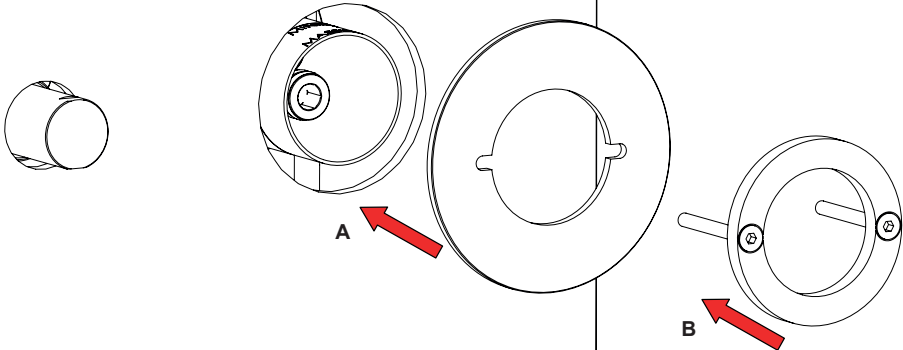

20

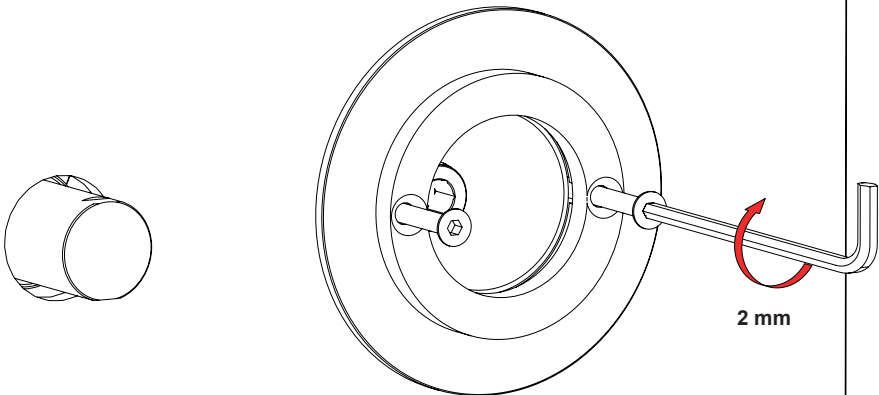

21

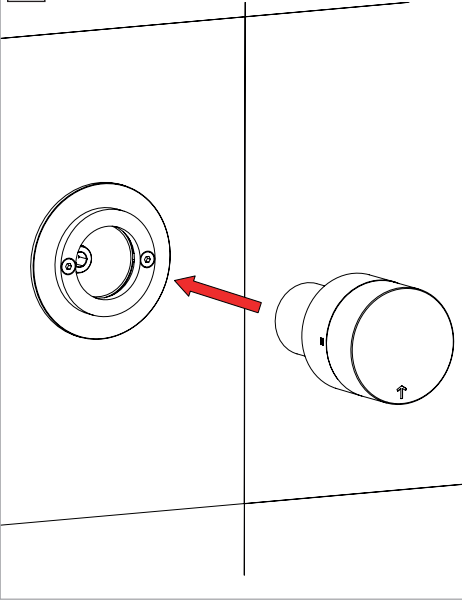

22

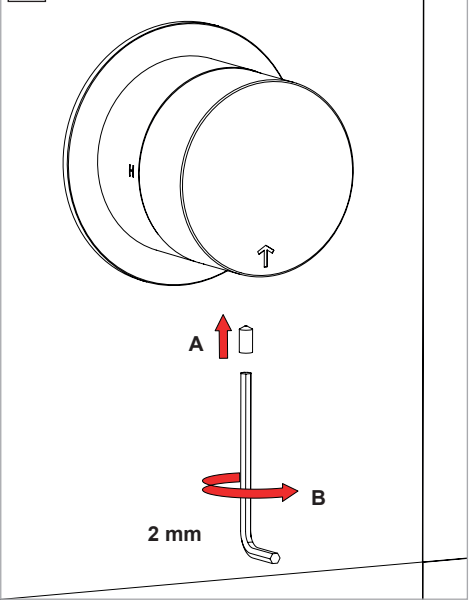

23

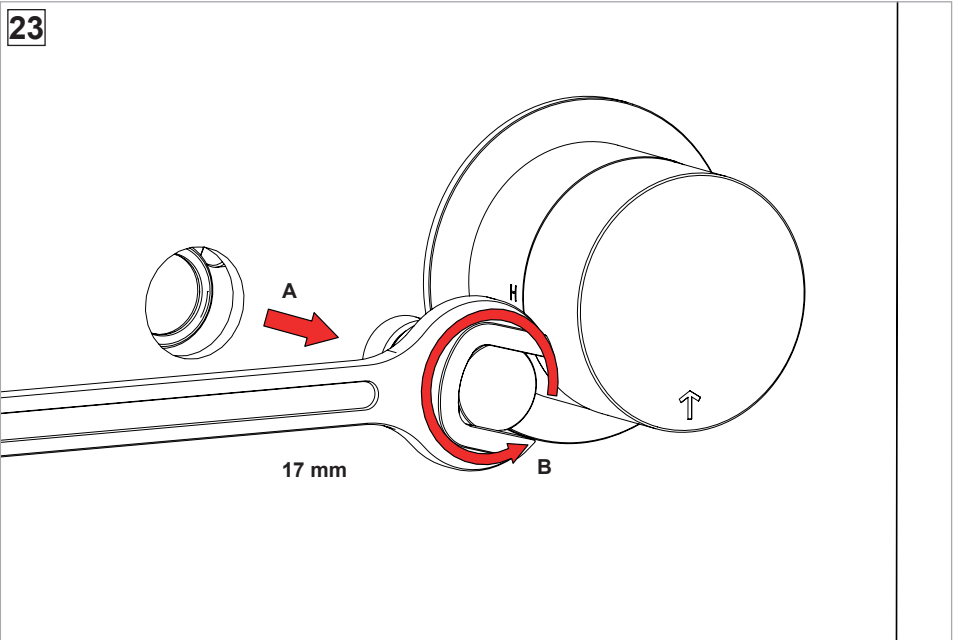

24

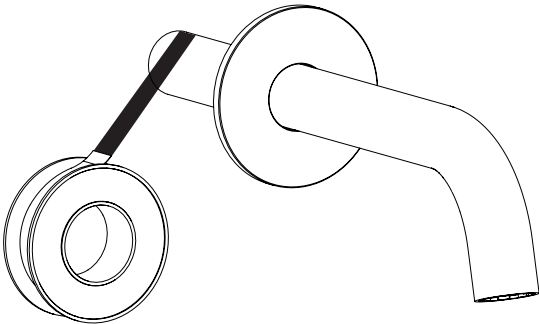

25

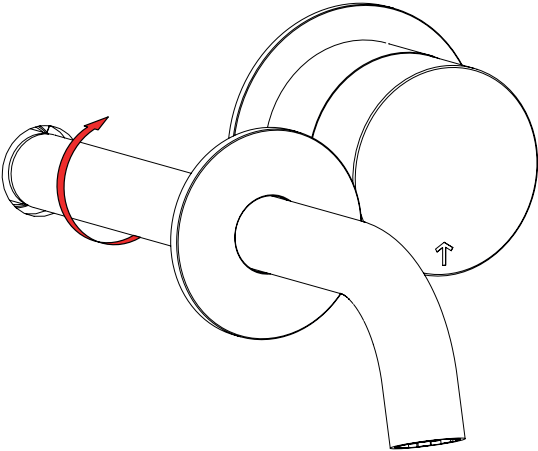

26

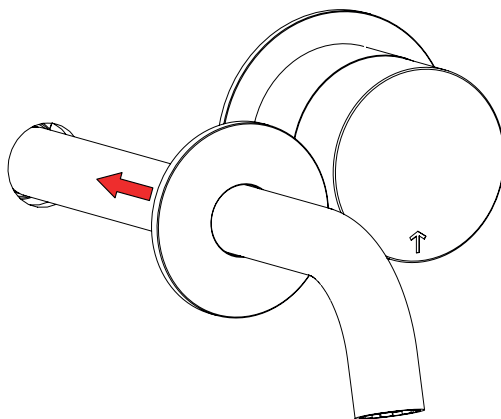

27

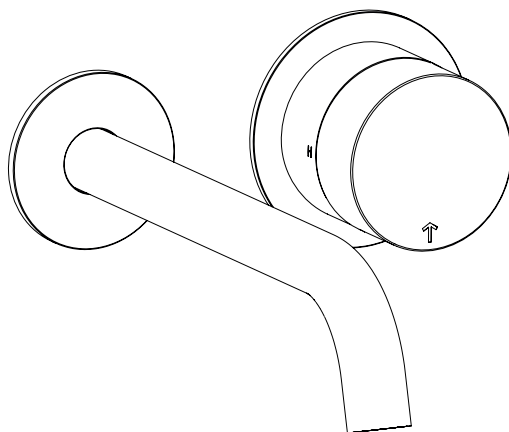

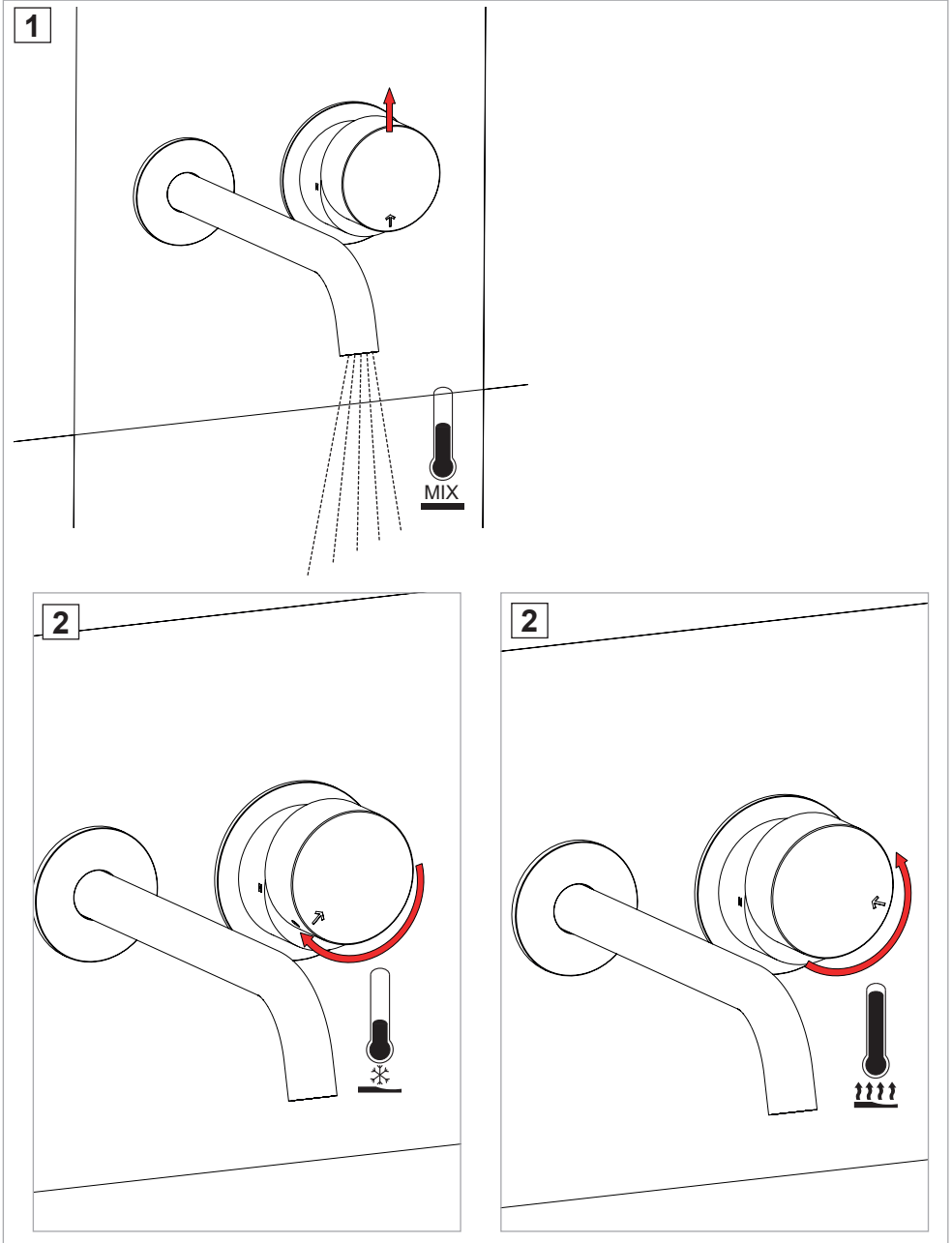

- EN** On first use or following prolonged periods of inactivity, do not use the first half-litre of drinking water dispensed. Shut off the plumbing system in the event of a long absence. Check the water-tightness regularly.
- FR** Lors de la première utilisation ou après une longue période de non utilisation, ne pas consommer le premier demi-litre d'eau potable qui sort du robinet. Fermer l'installation hydraulique en cas d'absence prolongée. Contrôler périodiquement l'étanchéité.
- ES** Durante el primer uso o tras un largo periodo de inactividad, no consumir el primer medio litro de agua potable que salga del grifo. Cerrar la instalación de agua si va a estar ausente durante un largo periodo. Comprobar periódicamente que no haya pérdidas.

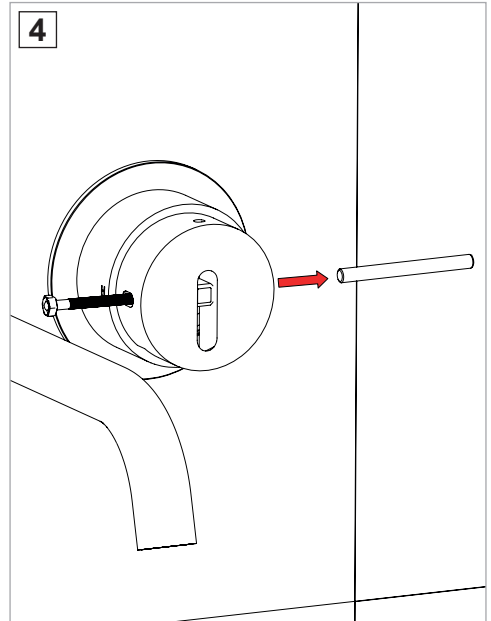
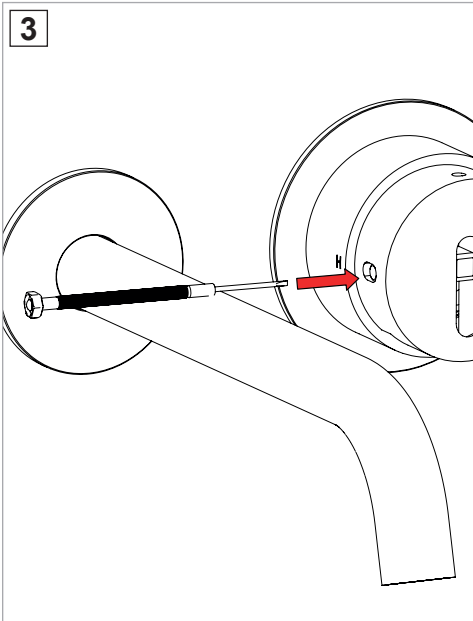
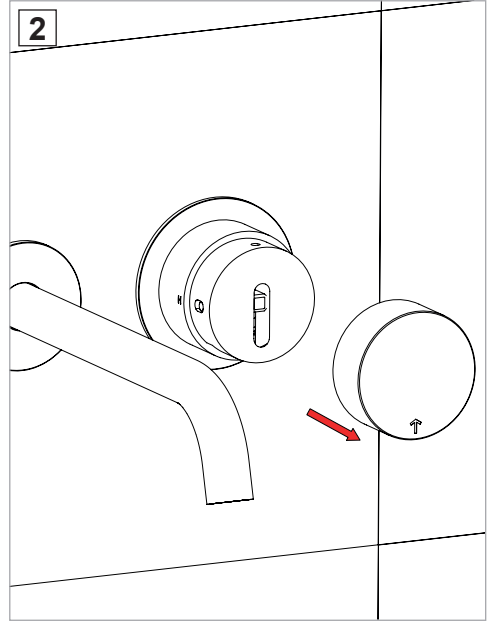
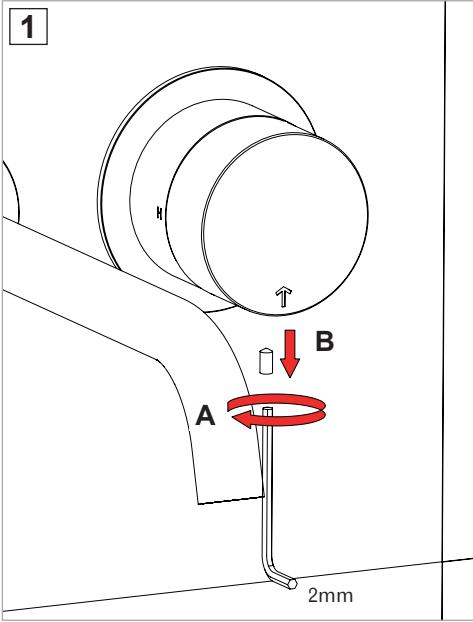
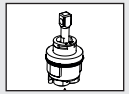

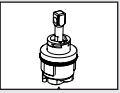

CARTRIDGE REPLACEMENT - REMPLACEMENT DE LA CARTOUCHE - SOSTITUZIONE DEL CARTUCCIO

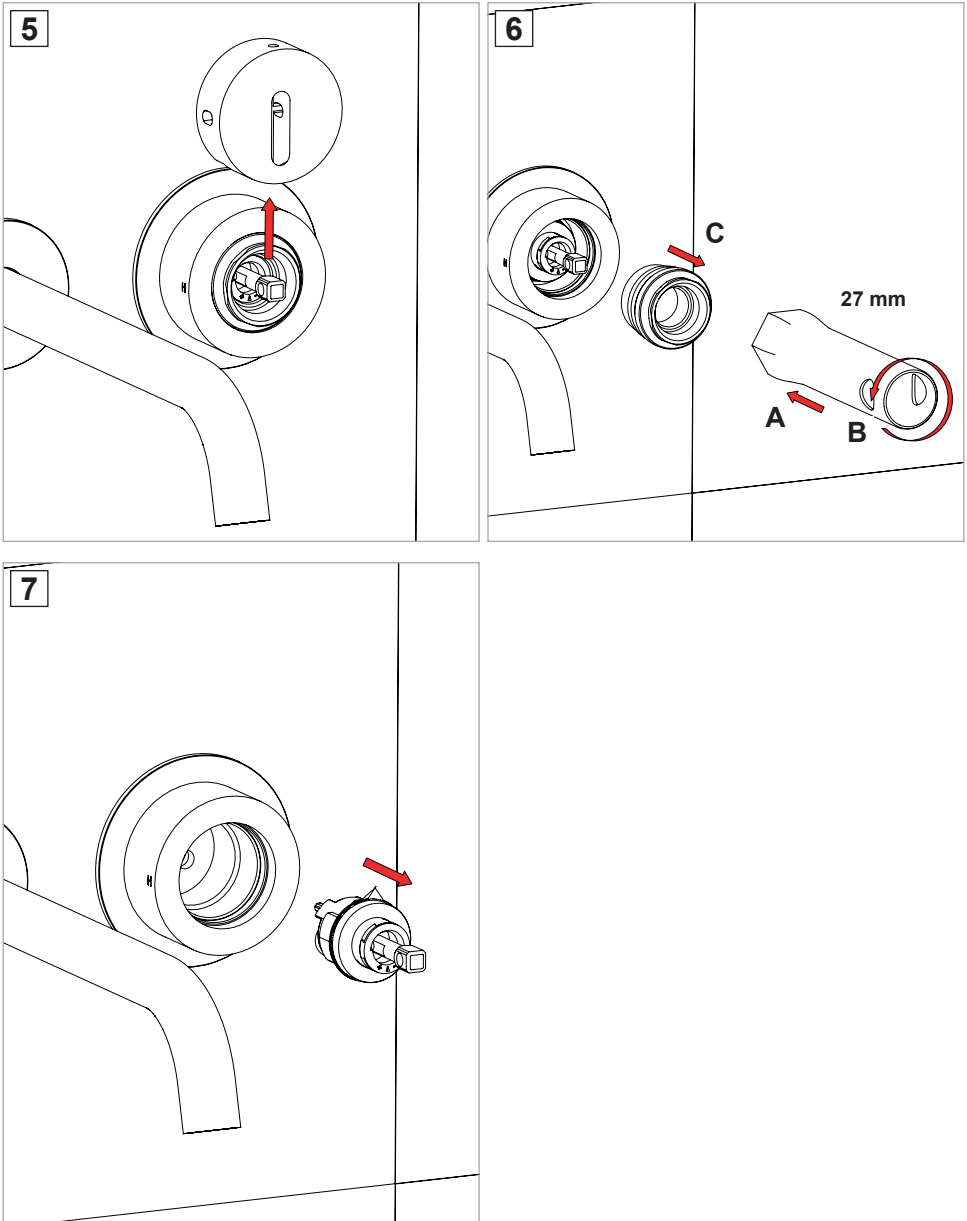

- Replace following the instructions in reverse order (7-6-5-4-3-2-1).
- Re-installer au contraire du procédé (7-6-5-4-3-2-1).
- Colocar según el procedimiento inverso (7-6-5-4-3-2-1).

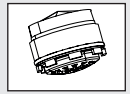

1

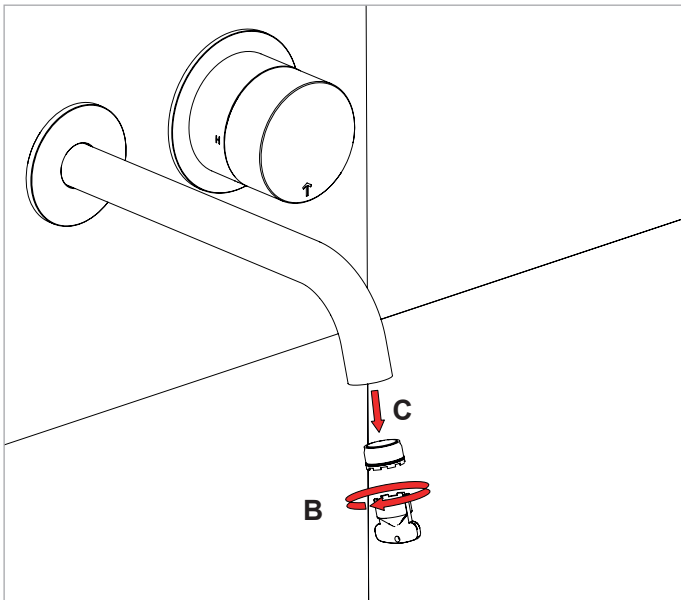
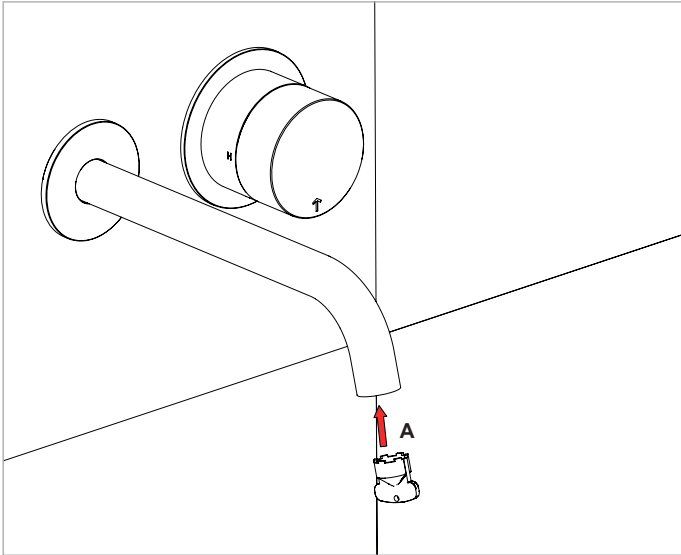

- Replace following the instructions in reverse order (2-1).
- Re-installer au contraire du procédé (2-1).
- Colocar según el procedimiento inverso (2-1).

ABOUTWATER

114000004000000U Rev. 0



ABOUTWATER

Boffi FANTINI

Fratelli Fantini SpA

via Buonarroti, 4
28010 Pella (NO) Italia
T +39 0322 918411 r.a.
F +39 0322 969530
www.aboutwater.it
www.fantini.it
fantini@fantini.it