

ART. J780B



DATI TECNICI - TECHNICAL DETAILS - DONNÉES TECHNIQUES

TECHNISCHE DATEN - DATOS TÉCNICOS - DADOS TÉCNICOS - ТЕХНИЧЕСКИЕ ДАННЫЕ

IT	EN	FR	
Pressione minima	Minimum pressure	Pression minimum	1 BAR
Pressione massima	Minimum pressure	Pression maximum	10 BAR
Press. di esercizio consigliata	Recommened working pressure	Pression optimale de service	2-5 BAR
Temperatura massima	Max. water temperature	Température maximum	80° C - 176° F
Temperatura massima consigliata	Maximum water temperature recommended	Température maximum optimale	65° C - 149° F
Differenza max di pressione in arrivo (calda - fredda)	Maximum in-let pressure difference (hot - cold)	Différence max. de pression d'arrivée (chaud - froid)	1.5 BAR

DE	ES	PT	RU	
Minimum druck	Pression mínima	Pressão mínima	Минимальное давление	1 BAR
Höchste druck	Pression máxima	Pressão máxima	Максимальное давление	10 BAR
Empfehlener druck	Pression de trab. aconsejada	Press. de funcionamento recomendada	Рекомендуемое рабочее давление	2-5 BAR
Höchste wasser Temperatur	Temperatura máxima	Temperatura máxima	Максимальная температура	80° C - 176° F
Wassertemperatur Höchste einkommende	Temperatura máxima aconsejada	Temperatura máxima recomendada	Максимальная рекомендуемая температура	65° C - 149° F
Höchste einkommende Drucksunterschied (Warm - kalt)	Diferencial max. de presiún de entrada (caliente - fria)	Diferença máxima de pressão na entrada (quente - fria)	Максимальный перепад давления по прибытии (горячая – холодная вода)	1.5 BAR

IT Se la pressione dell'acqua è superiore a 5 bar, è preferibile installare un riduttore di pressione a monte dell'alimentazione per evitare vibrazioni e rendere regolare la regolazione della temperatura.

EN If water pressure is above 5 bar, it is advisable to install a flow restrictor upstream of the water supply to avoid vibrations and regulate temperature.

FR Si la pression de l'eau est supérieure à 5 bar, il est recommandé d'installer un réducteur de pression en amont de l'alimentation afin d'éviter toute vibration et régulariser le réglage de la température.

DE Wenn der Wasserdruck über 5 bar liegt, sollte möglichst ein Druckminderer vor der Zuleitung montiert werden, um Schwingungen zu vermeiden und eine gleichmäßige Temperaturregelung zu ermöglichen.

ES Si la presión del agua supera los 5 bar, es preferible instalar un limitador de caudal en la conducción de la alimentación para evitar vibraciones y normalizar la regulación de la temperatura.

PT Se a pressão da água for superior a 5 bar, é preferível instalar um redutor de pressão antes do abastecimento

RU Если давление воды превышает 5 бар, желательно установить редуктор давления перед источником питания, чтобы избежать вибраций и обеспечить регулярное регулирование температуры.

IT Cura del prodotto

La pulizia delle superfici va fatta utilizzando un sapone liquido diluito in acqua. Non usare mai in nessun caso detersivi liquidi contenenti sostanze abrasive o a base di acido muriatico, spugne abrasive, aceto, ammoniaca, acetone, candeggina, acidi di uso domestico, disinfettanti vari. **ATTENZIONE!** L'impiego di prodotti non consigliati può deteriorare irrimediabilmente le superfici, nel qual caso il produttore non risponderà del danno. L'azienda si riserva in qualunque momento di apportare senza preavviso modifiche a prodotti e accessori. I dati riprodotti in questo documento hanno carattere informativo e non sono vincolanti.

EN Advice on product care

To clean the surface use a soap and water solution. Never use for any reason cleaning solutions containing abrasive substances, chloric acids, ammonia, vinegar, bleach, domestic acids, disinfectants, or anytype of abrasive pad. **WARNING!** Incorrect cleaning may permanently ruin the surface of the products and in such case the manufacturer may not be held liable for damage. The Manufacturer reserves the right to modify product and accessories at any time without prior notice. Datas, products and sketches included in this document are just for information and do not bind the producer.

FR Conseils pour l'entretien du produit

La poussière en surface devra être faite en utilisant un savon liquide dilué dans l'eau. Ne jamais utiliser en aucun cas des détergents liquides contenant des substances abrasives ou à base d'acide, nid'éponges abrasives, vinaigre, ammoniacque, acétone, eau de Javel, acides à usage domestique, désinfectants divers. **ATTENTION!** L'emploi de produits non conseillés peut détériorer irrémédiablement la surface des articles pour lesquels le fabricant ne sera pas responsable.

La société se réserve le droit de modifier ses produits et ses accessoires à tout moment et sans préavis. Informations, produits et croquis reproduits dans ce documents sont de nature informative et ne sont pas contractuels.

DE Pflege hinweise unserer artikel

Zur Reinigung empfehlen wir Wasser und flüssige Seife. Verwenden Sie bitte nie flüssige Reinigungsmittel, die Schmirgel, Salzsäure, Essig, Ammoniak, Aceton, Bleichlange, Desinfektionsmittel u.s.w. enthalten. **WARNUNG!** Der Gebrauch solcher Mittel kann unsere Artikel beschädigen und in diesem Fall gewährt Hersteller keine Garantie. Der Hersteller behält sich das Recht vor jederzeit Änderungen an seinen Produkten und Zubehörteilen ohne Vorbescheid vorzunehmen. Katalogangaben sowie Abbildungen sowie Maß- und Leistungsangaben sind unverbindlich.

ES Consejos para el cuidado del producto

La limpieza de las superficies se hace utilizando un jabón líquido diluido en agua. No usar en ningún caso detergentes líquidos que contengan sustancias abrasivas ó a base de ácido clorhídrico, estropajossabrosivos, amoniaco, acetona, lejía, ácidos de uso doméstico, desinfectantes varios. **ATENCIÓN!** El uso de productos desaconsejados puede danar irremediamente las superficies de los elementos, de lo cual el fabricante no se hará responsable en ningún caso. La sociedad se reserva el derecho de modificar sus productos y accesorios en cualquier momento y sin previo avi

PT Cuidado do produto

A limpeza das superfícies deve ser feita utilizando um pano macio humedecido com sabão líquido diluído em água: no fim enxagüe e seque bem. Não use, em caso algum, detergentes com substâncias abrasivas ou à base de ácido muriático, vinagre, amoníaco, acetona, lixívia, ácidos de uso doméstico, desinfetantes ou esponjas abrasivas. **ATENÇÃO!** A utilização de produtos não recomendados pode danificar irremediavelmente as superfícies, nesse caso o produtor não se responsabiliza pelo dano. Se a distribuição de água diminuir limpe ou substitua o emulsor situado entre a bica e o tubo flexível. so.

RU Уход за продуктом

Очистку поверхности следует производить жидким мылом, разведенным в воде. Ни при каких обстоятельствах не используйте жидкие моющие средства, содержащие абразивные вещества или на основе соляной кислоты, абразивные губки, уксус, аммиак, ацетон, отбеливатель, бытовые кислоты, различные дезинфицирующие средства. **ПРЕДУПРЕЖДЕНИЕ!** Использование нереконмендованных продуктов может привести к непоправимому повреждению поверхностей, и в этом случае производитель не несет ответственности за ущерб. Компания оставляет за собой право вносить изменения в продукты и аксессуары в любое время без предварительного уведомления. Данные, представленные в этом документе, носят информативный характер и не являются обязательными.

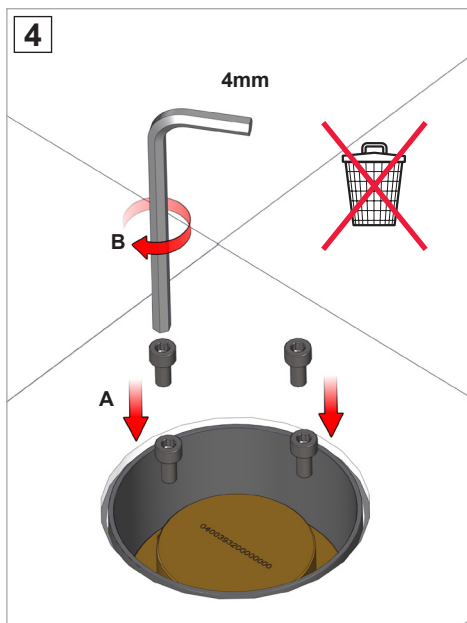
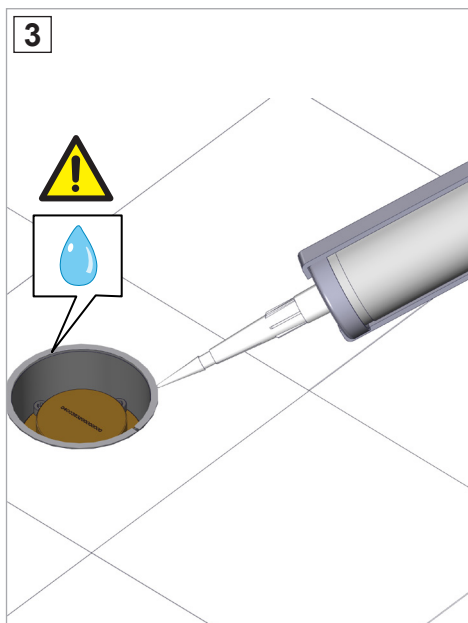
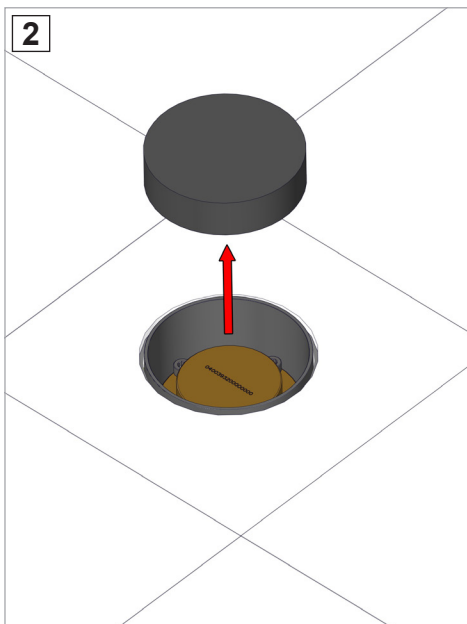
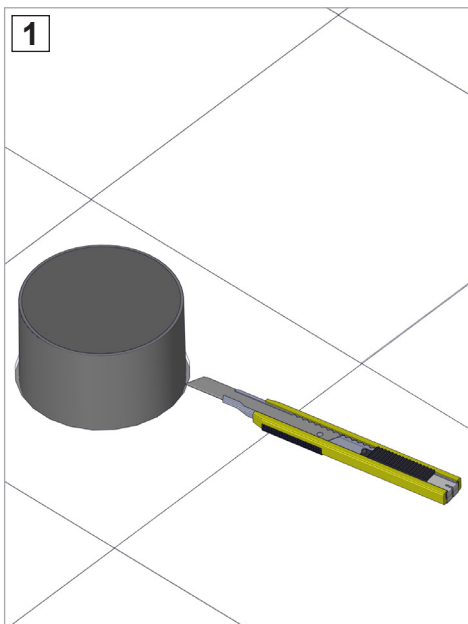

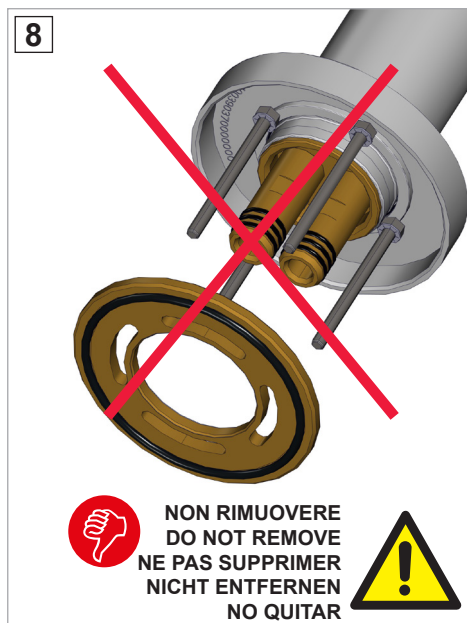
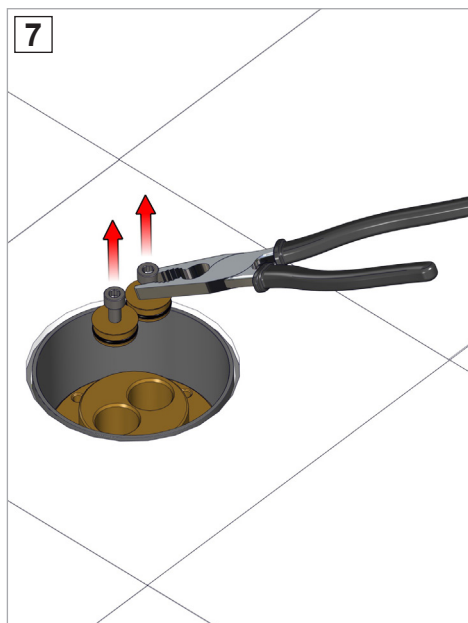
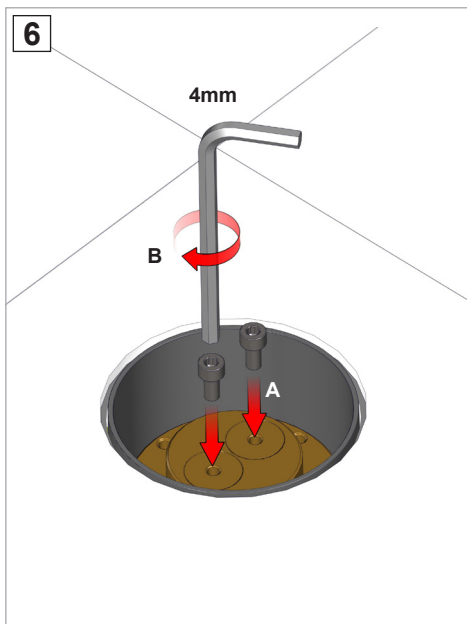
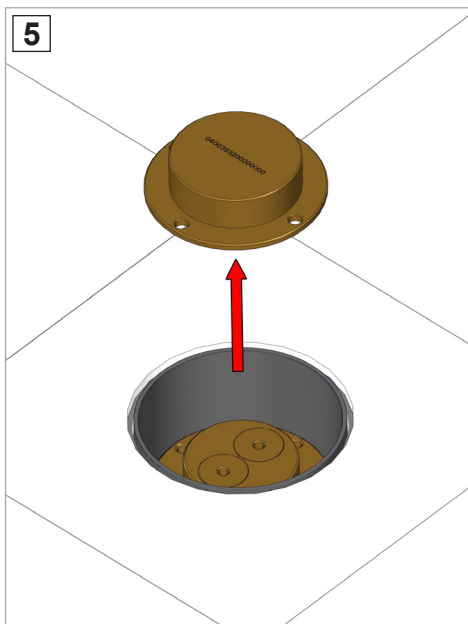

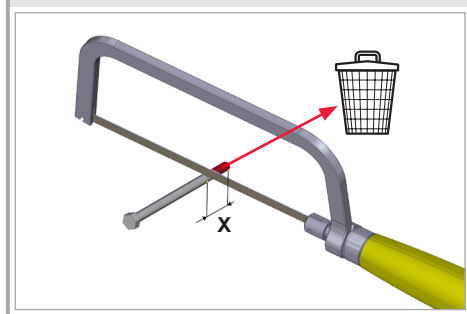
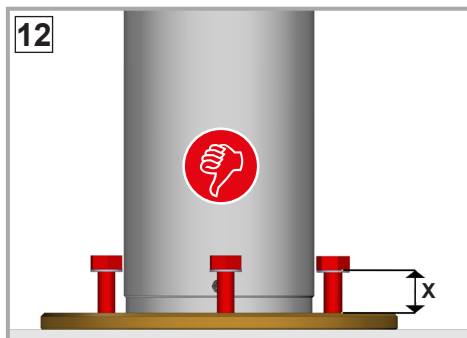
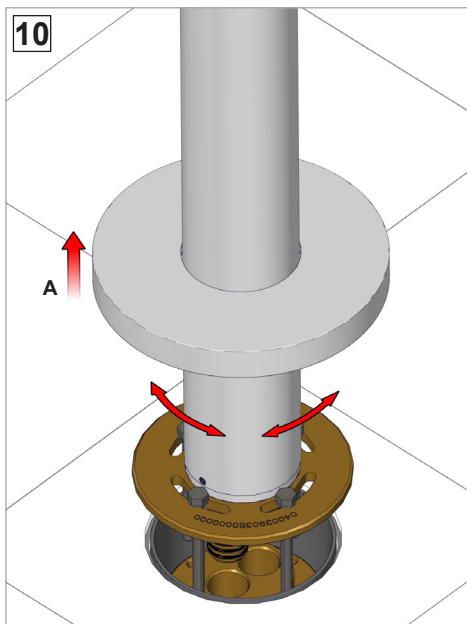
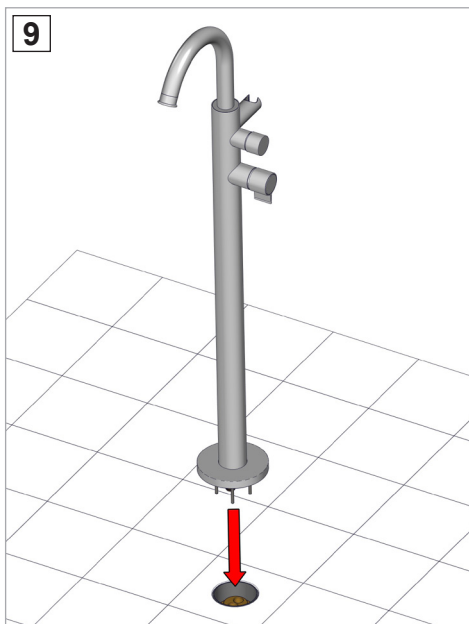

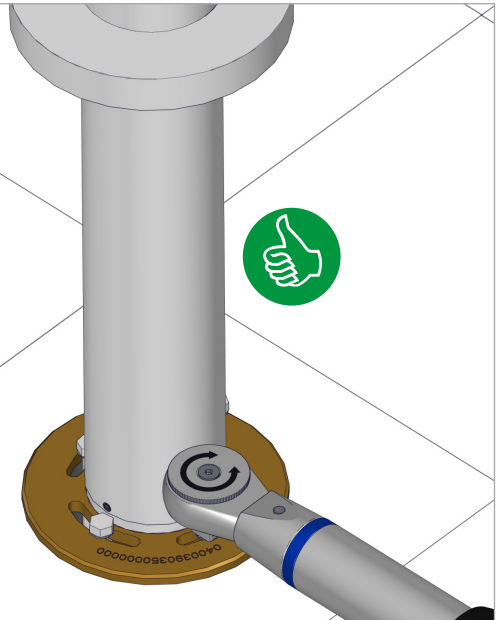
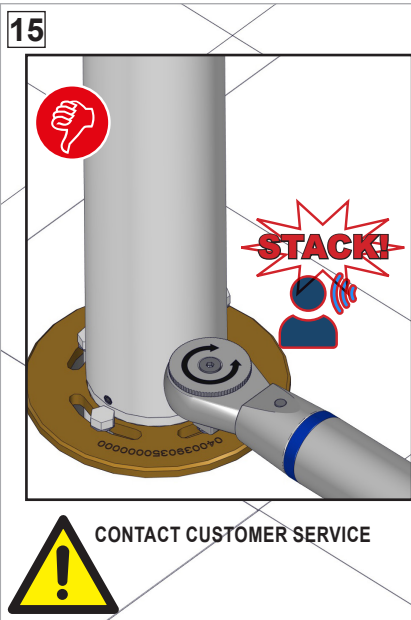
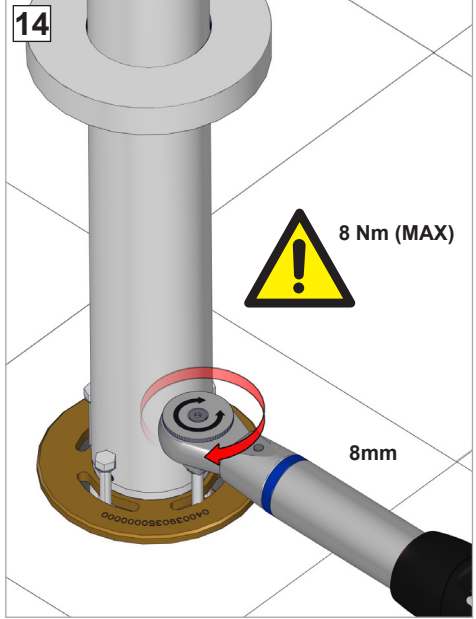
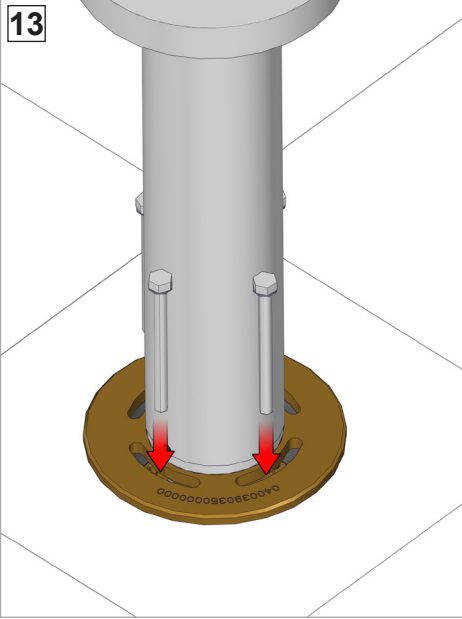

16

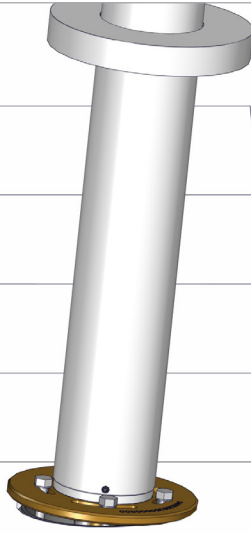

CONTACT CUSTOMER SERVICE

17

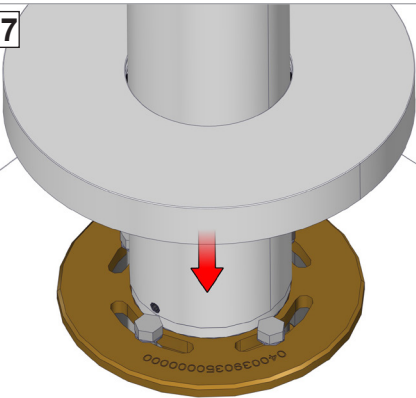

18

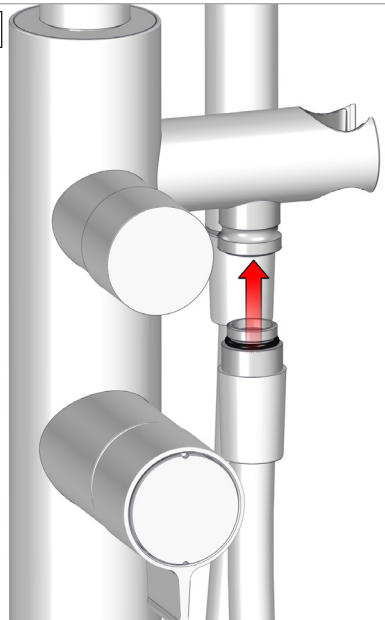

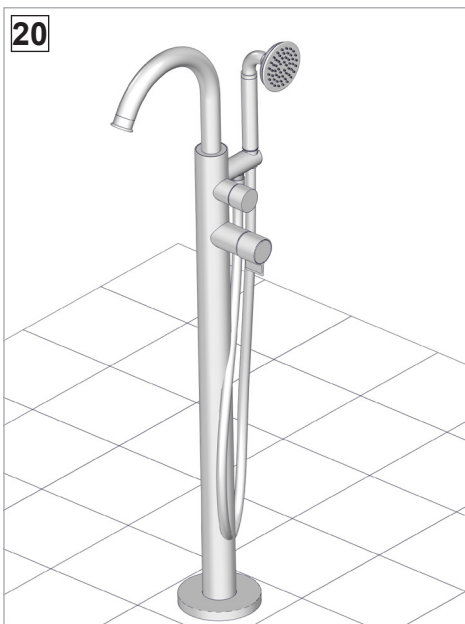
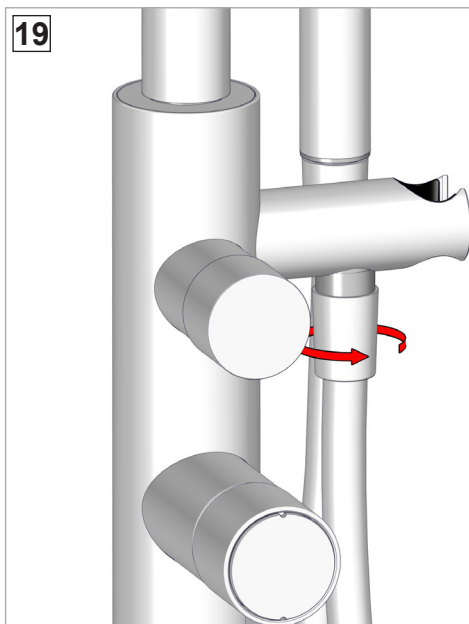

- IT** Al primo utilizzo o dopo un lungo periodo di inutilizzo, non consumare il primo mezzo litro di acqua potabile erogata. Chiudere l'impianto idraulico in caso di prolungata assenza. Controllare periodicamente la tenuta.
- EN** On first use or following prolonged periods of inactivity, do not use the first half-litre of drinking water dispensed. Shut off the plumbing system in the event of a long absence. Check the water-tightness regularly.
- FR** Lors de la première utilisation ou après une longue période de non utilisation, ne pas consommer le premier demi-litre d'eau potable qui sort du robinet. Fermer l'installation hydraulique en cas d'absence prolongée. Contrôler périodiquement l'étanchéité.
- DE** Schütten Sie bei Erstbenutzung oder nach einem längeren Zeitraum der Nichtbenutzung den ersten halben Liter Trinkwasser weg. Stellen Sie das Wasser bei längerer Abwesenheit ab. Prüfen Sie in regelmäßigen Abständen die Dichtheit.
- ES** Durante el primer uso o tras un largo periodo de inactividad, no consumir el primer medio litro de agua potable que salga del grifo. Cerrar la instalación de agua si va a estar ausente durante un largo periodo. Comprobar periódicamente que no haya pérdidas.
- PT** Na primeira utilização ou após um longo período de inutilização, não consuma o primeiro meio litro de água potável distribuída. Feche o circuito hidráulico no caso de ausência prolongada. Verifique periodicamente a vedação.
- RU** При первом использовании или после длительного простоя не употребляйте первые пол-литра подаваемой питьевой воды. Закройте водопроводную систему в случае длительного отсутствия. Периодически проверяйте герметичность.

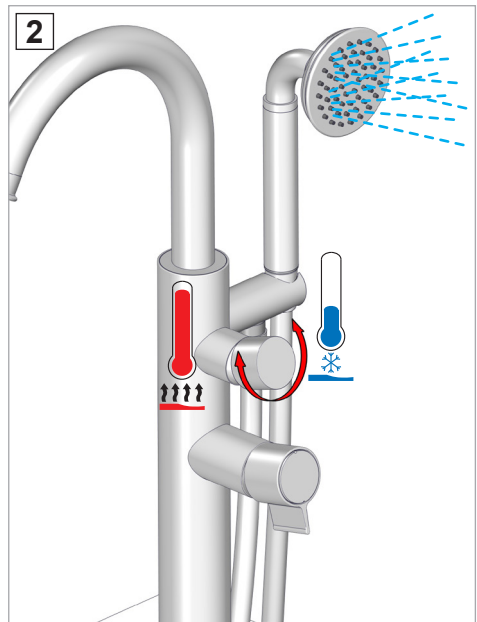
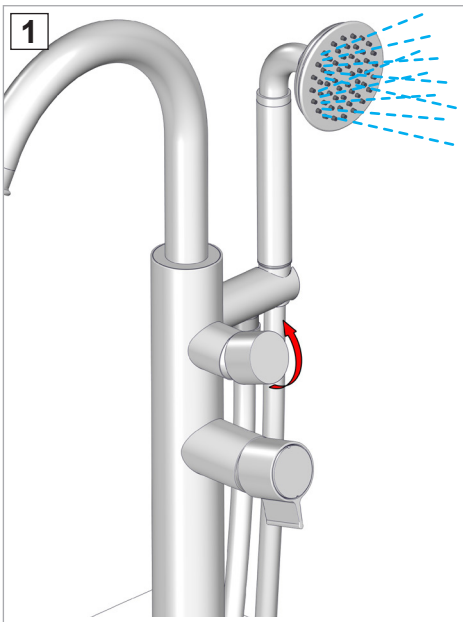
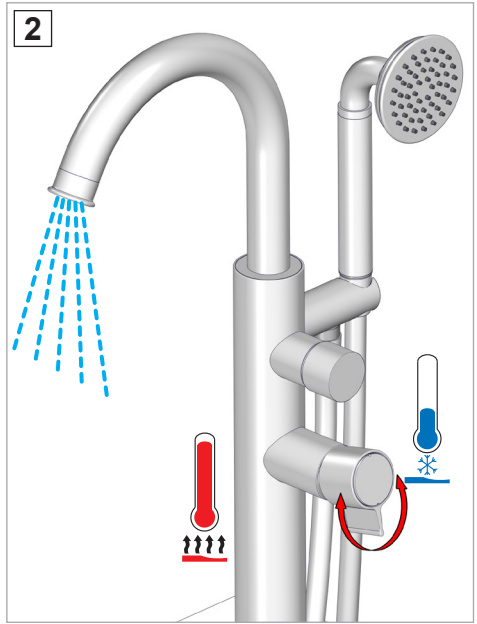
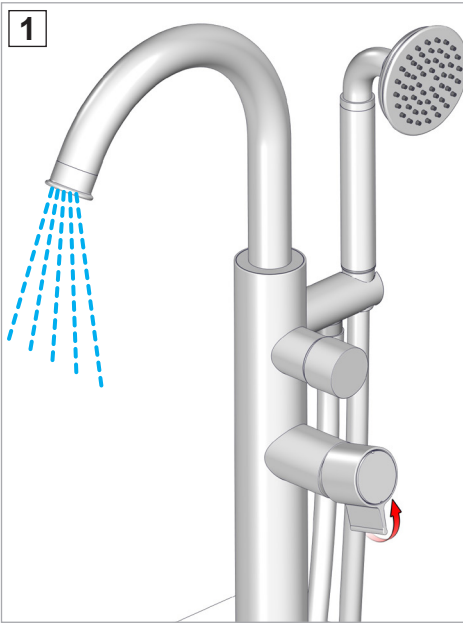

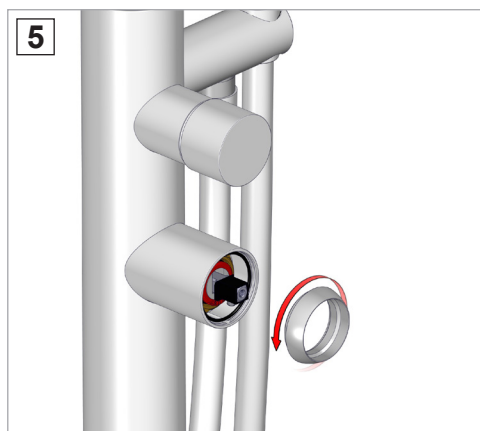
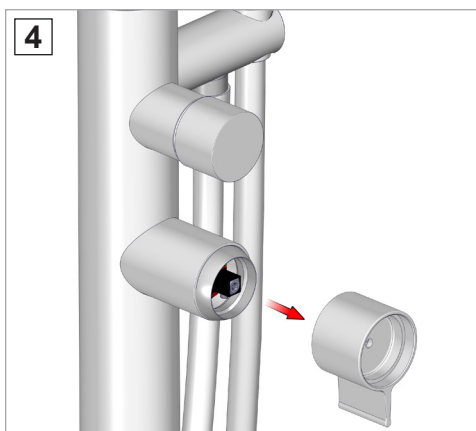
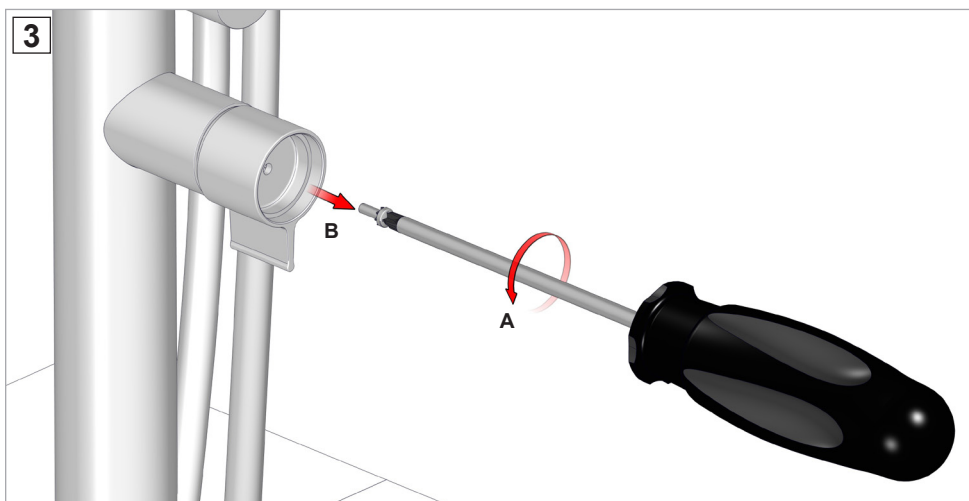
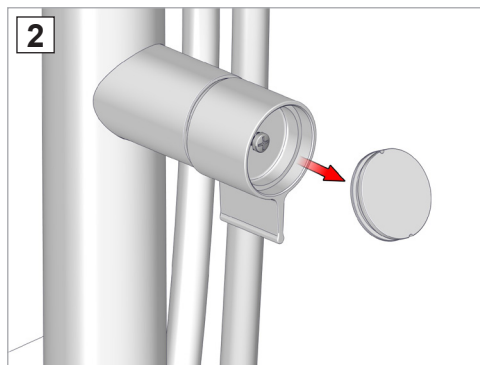
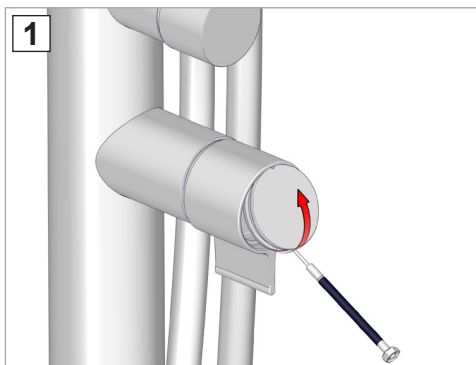
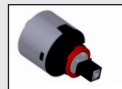

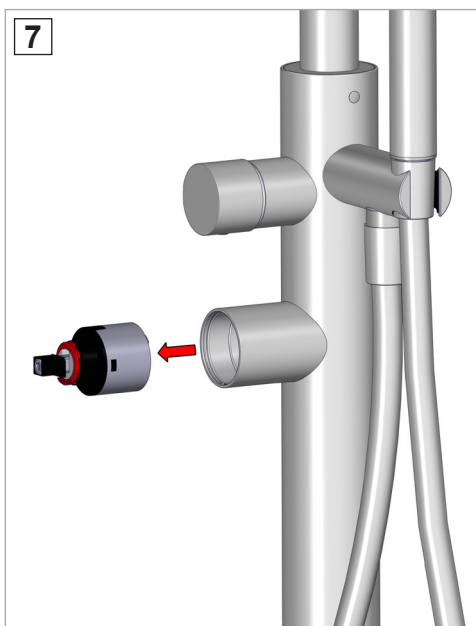
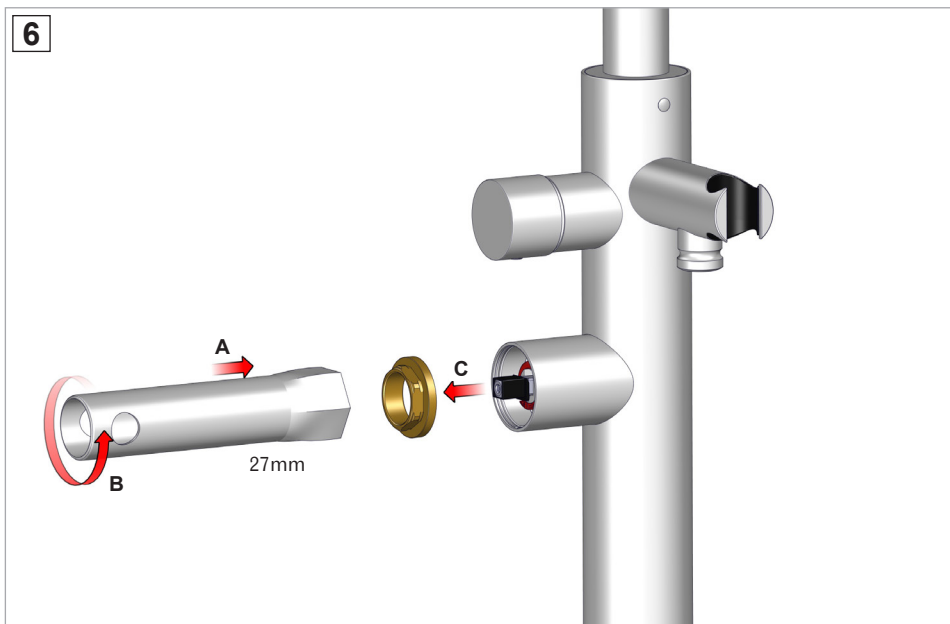

- Rimontare seguendo il procedimento inverso (7-6-5-4-3-2-1).
- Replace following the instructions in reverse order (7-6-5-4-3-2-1).
- Re-installer au contraire du procédé (7-6-5-4-3-2-1).
- Die umgekehrte Vorgehensweise folgen um die Teil wieder zu installieren (7-6-5-4-3-2-1).
- Colocar según el procedimiento inverso (7-6-5-4-3-2-1).
- Соберите в обратном порядке (7-6-5-4-3-2-1).

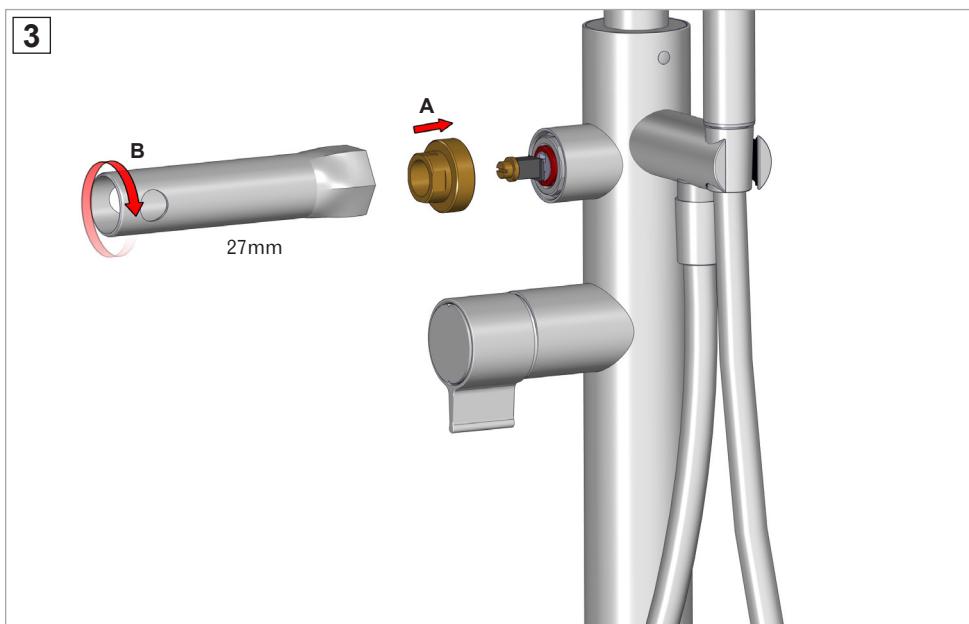
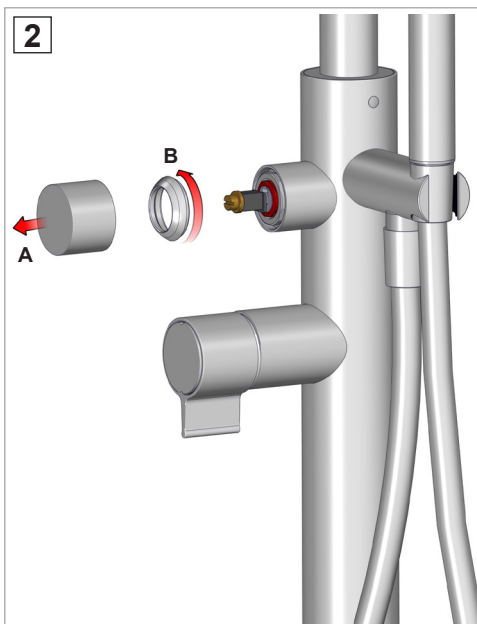
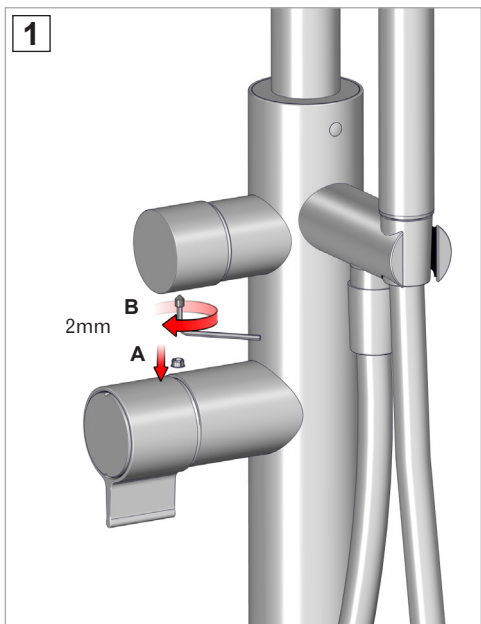

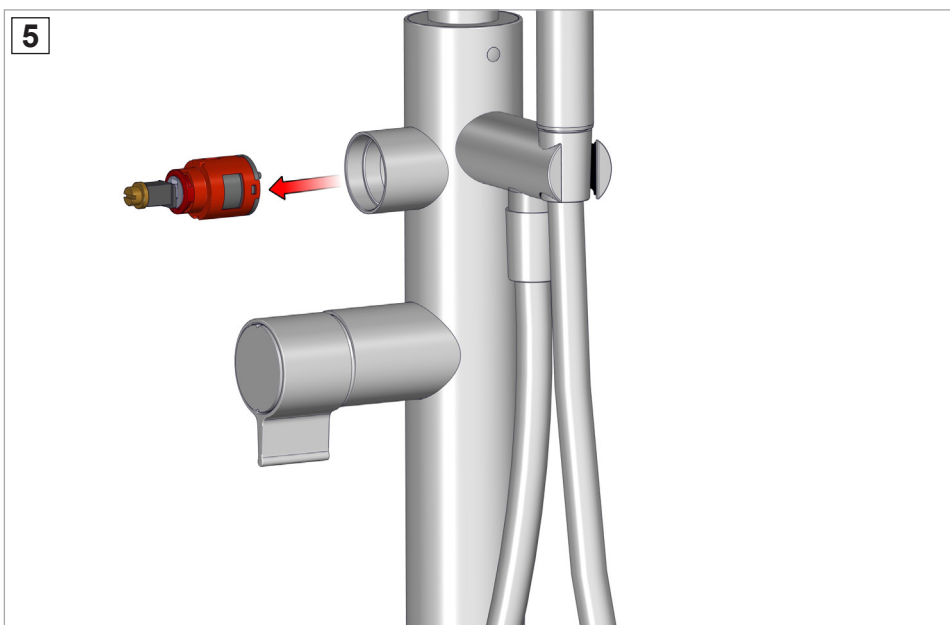
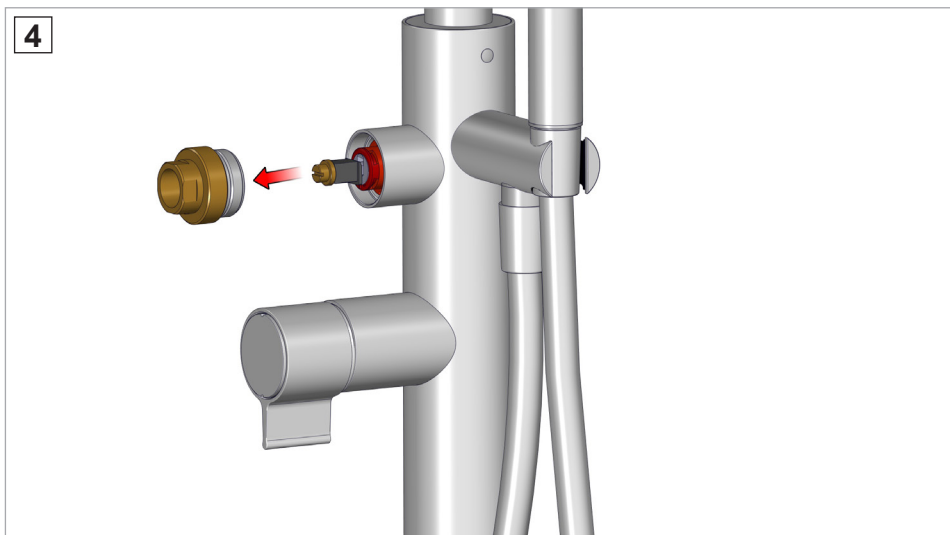

- Rimontare seguendo il procedimento inverso (5-4-3-2-1).
- Replace following the instructions in reverse order (5-4-3-2-1).
- Re-installer au contraire du procédé (5-4-3-2-1).
- Die umgekehrte Vorgehensweise folgen um die Teil wieder zu installieren (5-4-3-2-1).
- Colocar según el procedimiento inverso (5-4-3-2-1).
- Соберите в обратном порядке (5-4-3-2-1).



Fratelli Fantini Spa
via Buonarroti, 4
Pella (NO) Italia
T +39 0322 918411 r.a.
F +39 0322 969530
fantini@fantini.it
www.fantini.it



117600012000000 Rev. 0