

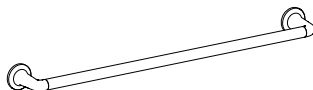

ART. H906



ART. H911



ART. H907



ART. H944



ART. H945



ART. H946

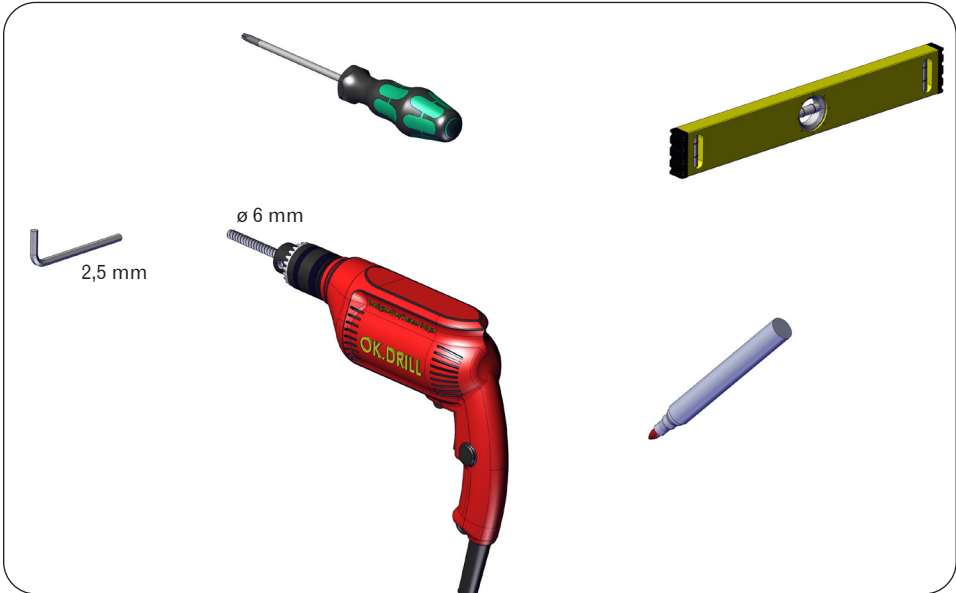

IT Cura del prodotto

La pulizia delle superfici va fatta utilizzando un sapone liquido diluito in acqua. Non usare mai in nessun caso detersivi liquidi contenenti sostanze abrasive o a base di acido muriatico, spugne abrasive, aceto, ammoniaca, acetone, candeggina, acidi di uso domestico, disinfettanti vari. **ATTENZIONE!** L'impiego di prodotti non consigliati può deteriorare irrimediabilmente le superfici, nel qual caso il produttore non risponderà del danno. L'azienda si riserva in qualunque momento di apportare senza preavviso modifiche a prodotti e accessori. I dati riprodotti in questo documento hanno carattere informativo e non sono vincolanti.

EN Advice on product care

To clean the surface use a soap and water solution. Never use for any reason cleaning solutions containing abrasive substances, chloric acids, ammonia, vinegar, bleach, domestic acids, disinfectants, or anytype of abrasive pad. **WARNING!** Incorrect cleaning may permanently ruin the surface of the products and in such case the manufacturer may not be held liable for damage. The Manufacturer reserves the right to modify product and accessories at any time without prior notice. Datas, products and sketches included in this document are just for information and do not bind the producer.

FR Conseils pour l'entretien du produit

La poussière en surface devra être faite en utilisant un savon liquide dilué dans l'eau. Ne jamais utiliser en aucun cas des détergents liquides contenant des substances abrasives ou à base d'acide, nid'éponges abrasives, vinaigre, ammoniacque, acétone, eau de Javel, acides à usage domestique, désinfectants divers. **ATTENTION!** L'empli de produits non conseillés peut détériorer irrémédiablement la surface des articles pour lesquels le fabricant ne sera pas responsable. La société se réserve le droit de modifier ses produits et ses accessoires à tout moment et sans préavis. Informations, produits et croquis reproduits dans ce documents sont de nature informative et ne sont pas contractuels.

DE Pflege hinweise unserer artikel

Zur Reinigung empfehlen wir Wasser und flüssige Seife. Verwenden Sie bitte nie flüssige Reinigungsmittel, die Schmirgel, Salzsäure, Essig, Ammoniak, Aceton, Bleichlange, Desinfektionsmittel u.s.w. enthalten. **WARNUNG!** Der Gebrauch solcher Mittel kann unsere Artikel beschädigen und in diesem Fall gewährt Hersteller keine Garantie. Der Hersteller behält sich das Recht vor jederzeit Änderungen an seinen Produkten und Zubehörteilen ohne Vorbescheid vorzunehmen. Katalogangaben sowie Abbindungen, Maß- und Leistungsangaben sind unverbindlich.

ES Consejos para el cuidado del producto

La limpieza de las superficies se hace utilizando un jabón líquido diluido en agua. No usar en ningún caso detergentes líquidos que contengan sustancias abrasivas ó a base de ácido clorhídrico, estropajossabrasivos, amoniaco, acetona, lejía, ácidos de uso doméstico, desinfectantes varios. **ATENCIÓN!** El uso de productos desaconsejados puede danar irremediamente las superficies de los elementos, de lo cual el fabricante no se hará responsable en ningún caso. La sociedad se reserva el derecho de modificar sus productos y accesorios en cualquier momento y sin previo avi

PT Cuidado do produto

A limpeza das superfícies deve ser feita utilizando um pano macio humedecido com sabão líquido diluído em água: no fim enxágue e seque bem. Não use, em caso algum, detergentes com substâncias abrasivas ou à base de ácido muriático, vinagre, amoníaco, acetona, lixívia, ácidos de uso doméstico, desinfetantes ou esponjas abrasivas. **ATENÇÃO!** A utilização de produtos não recomendados pode danificar irremediavelmente as superfícies, nesse caso o produtor não se responsabiliza pelo dano. Se a distribuição de água diminuir limpe ou substitua o emulsor situado entre a bica e o tubo flexível. so.

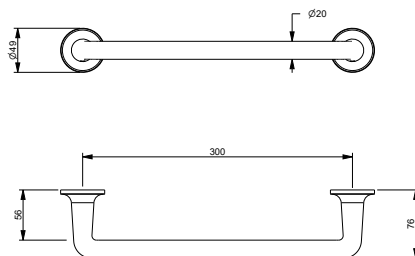

ART. H906 Portasalviette 30 cm. / Towel Rail 30 cm. / Porte-serviettes 30 cm. / Handtuchstange 30 cm. / Toallero 30 cm.

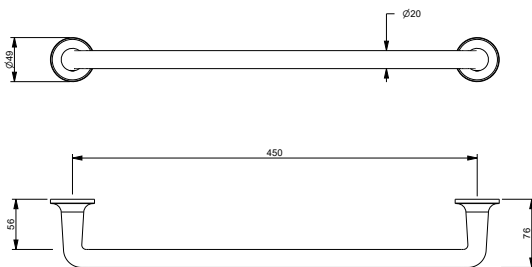

ART. H911 Portasalviette 45 cm. / Towel Rail 45 cm. / Porte-serviettes 45 cm. / Handtuchstange 45 cm. / Toallero 45 cm.

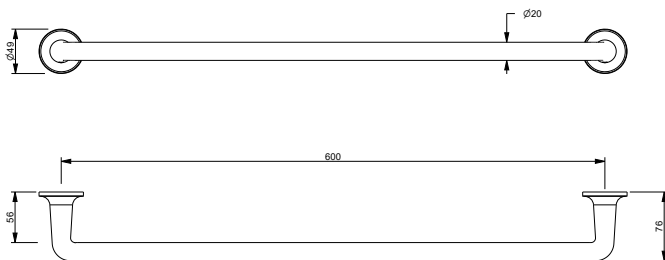
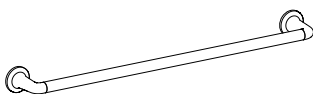

ART. H907 Portasalviette 60 cm. / Towel Rail 60 cm. / Porte-serviettes 60 cm. / Handtuchstange 60 cm. / Toallero 60 cm.

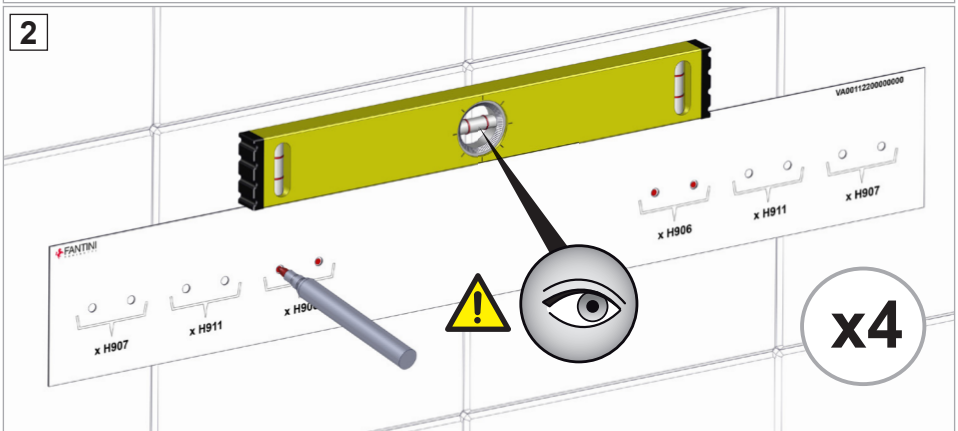
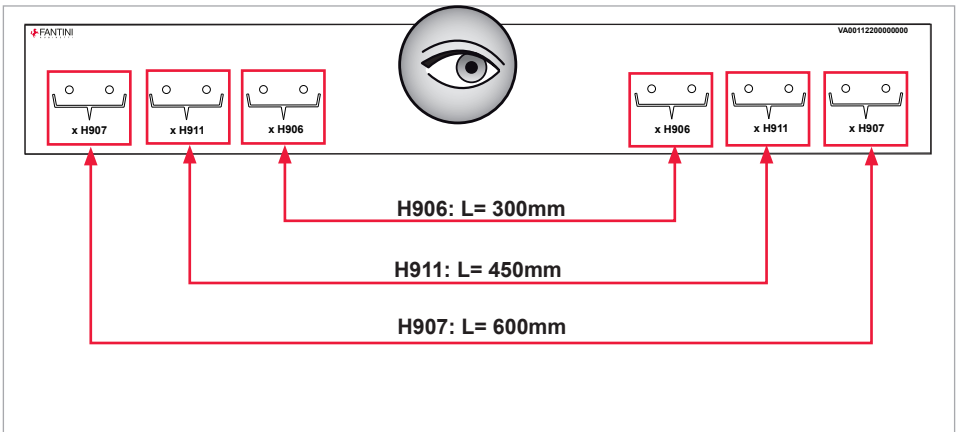
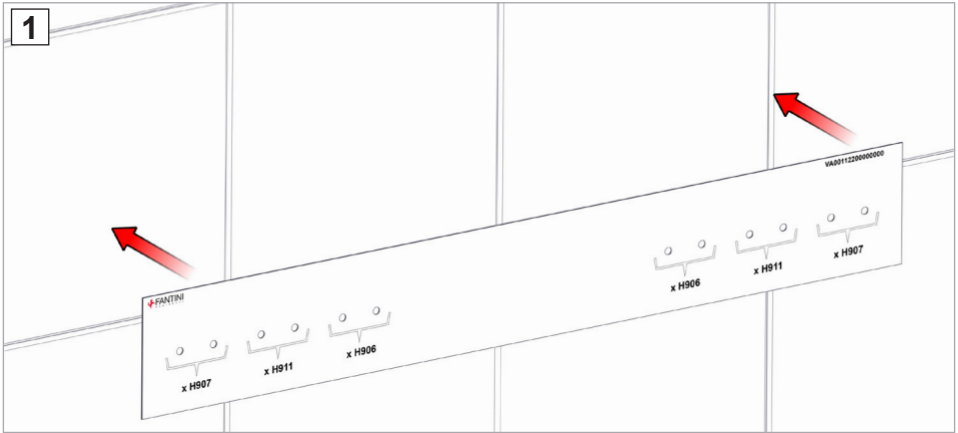

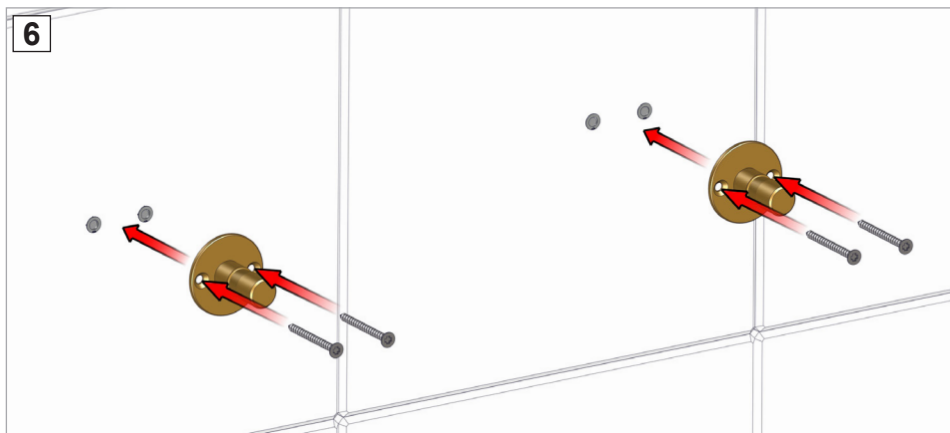
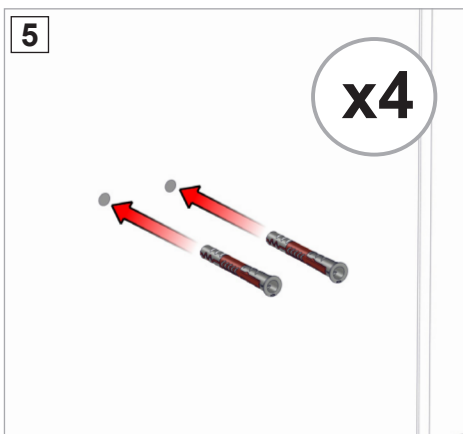
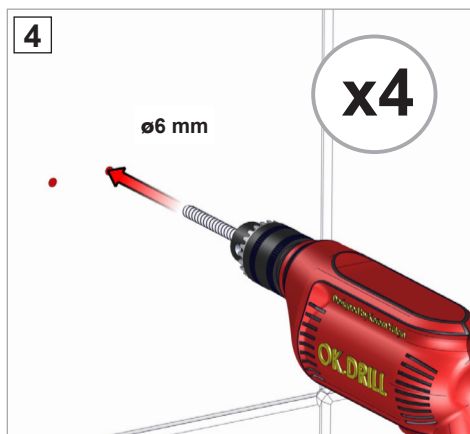
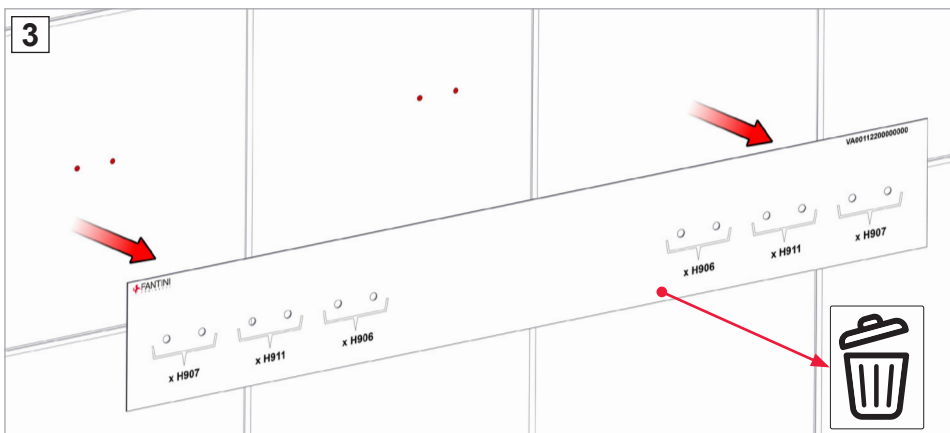

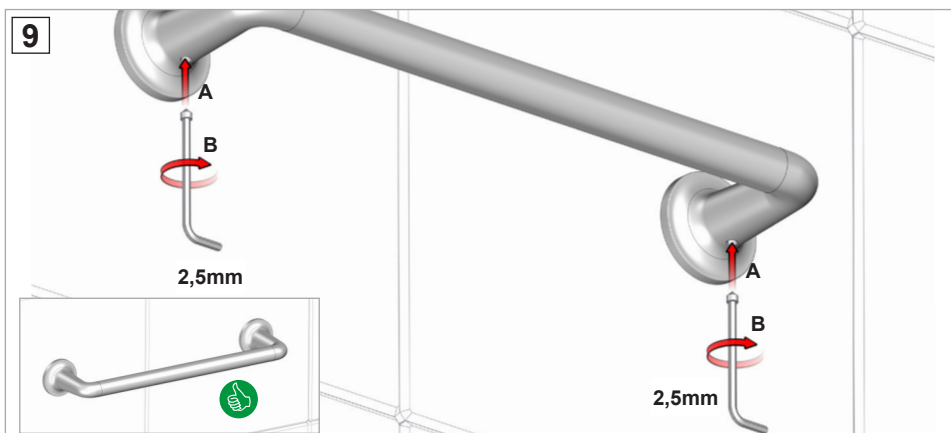
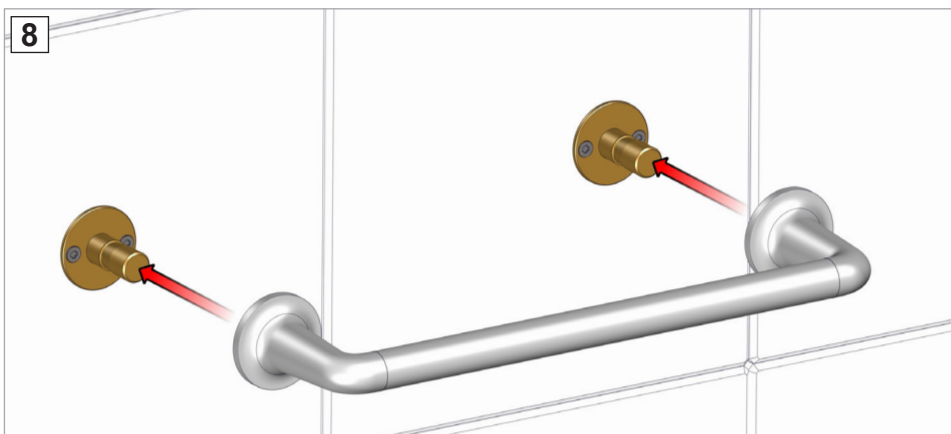
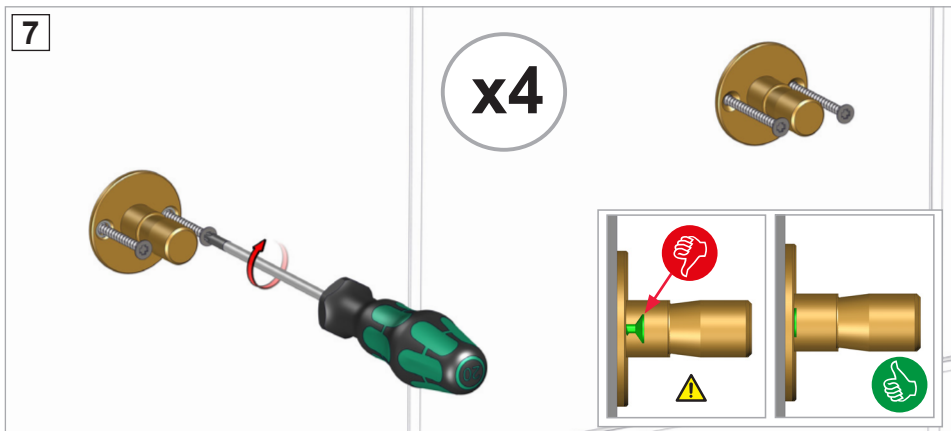

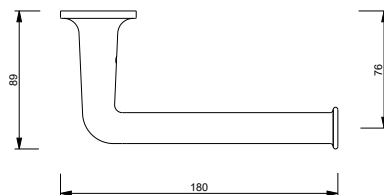
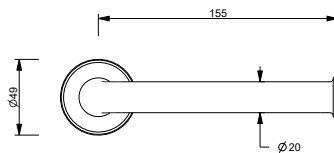

ART. H945

Portarotolo / Toilet roll holder / Porte papier / Papierrollenhalter /
Portarrollos

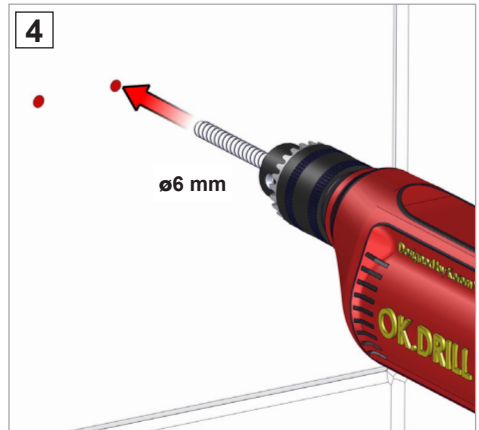
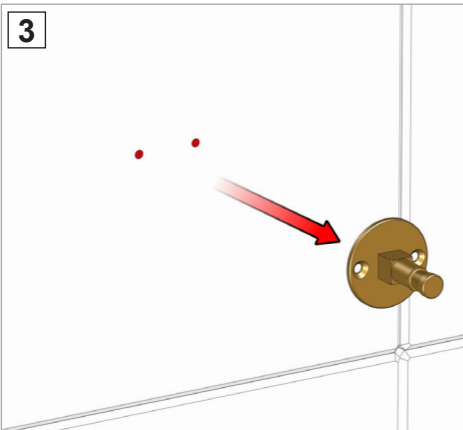
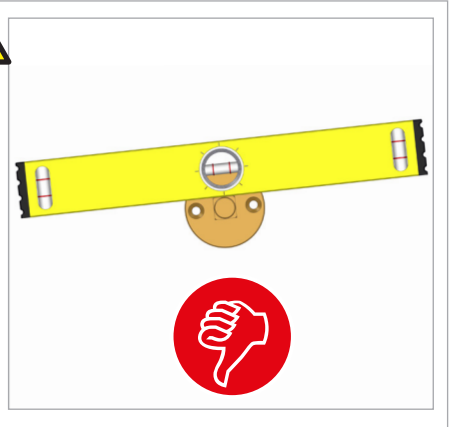
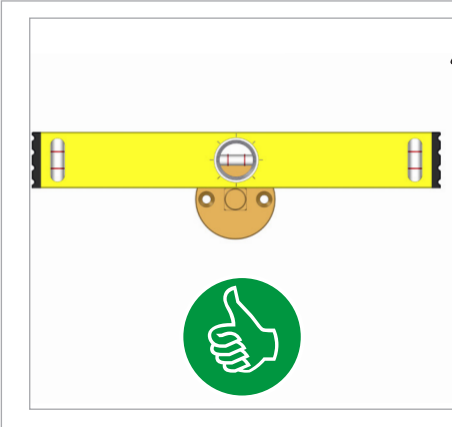
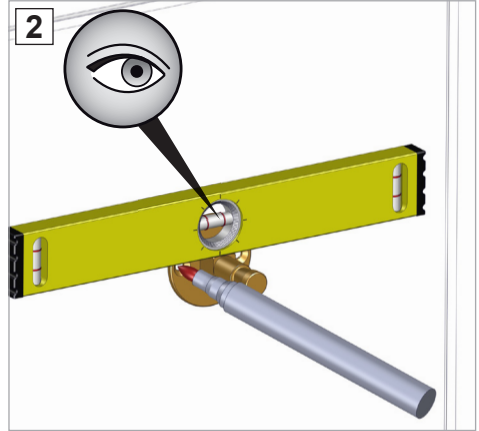
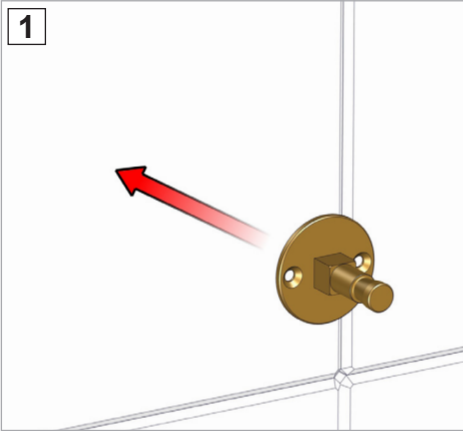

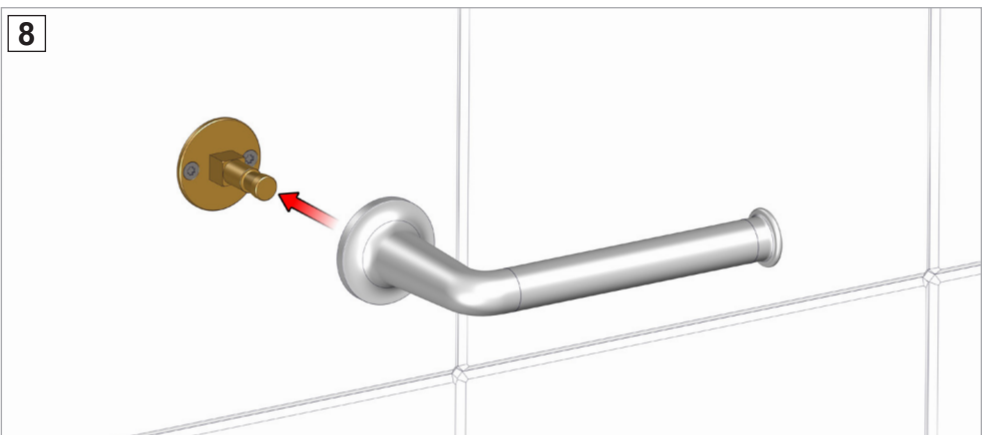
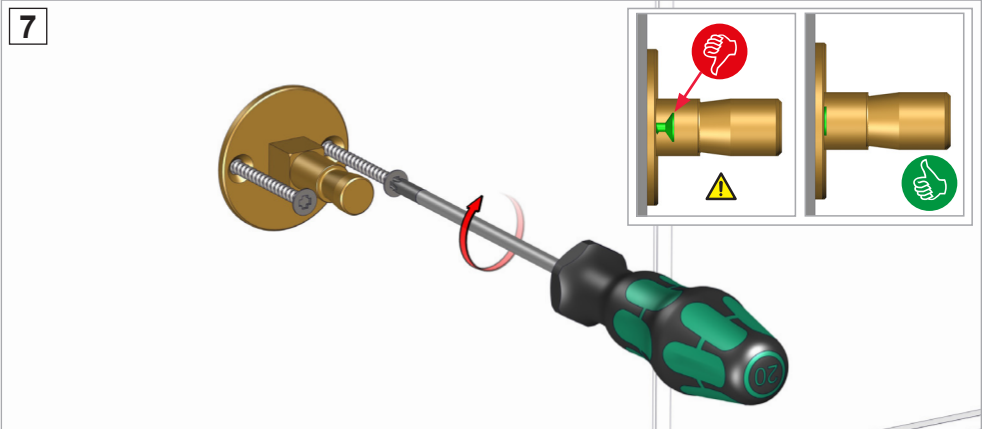
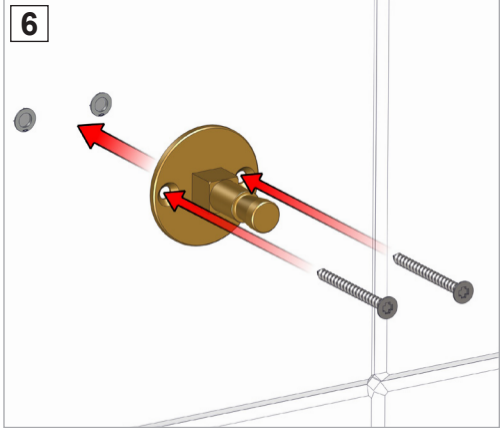
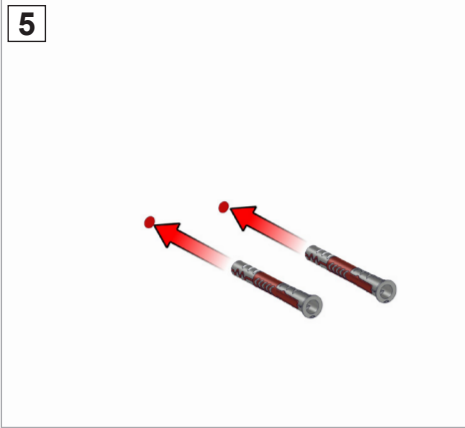

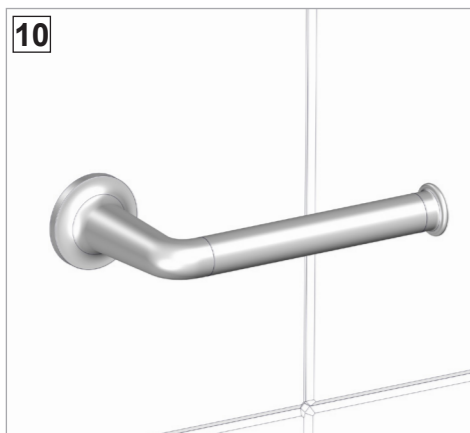
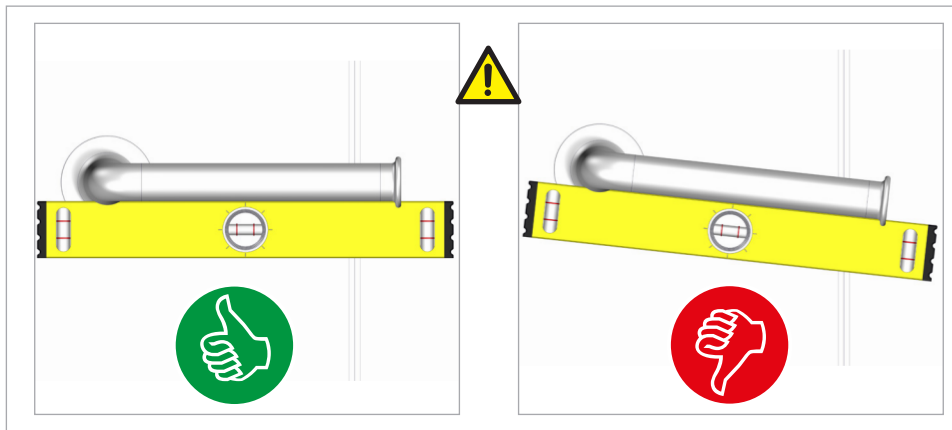
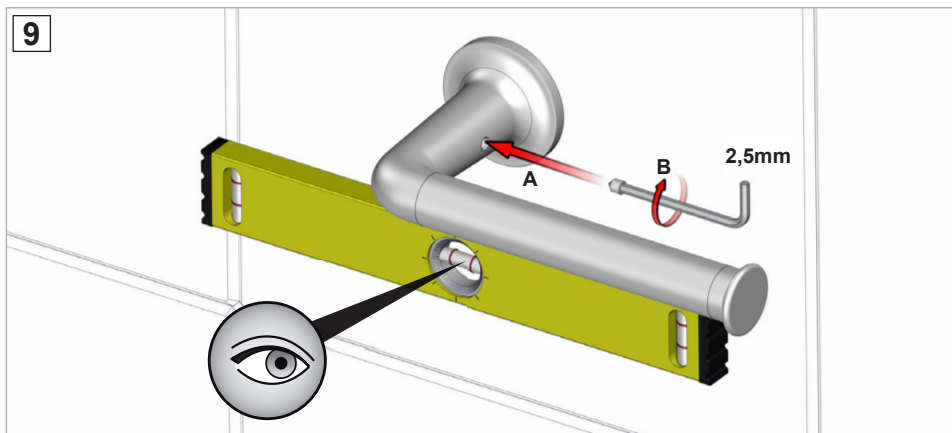

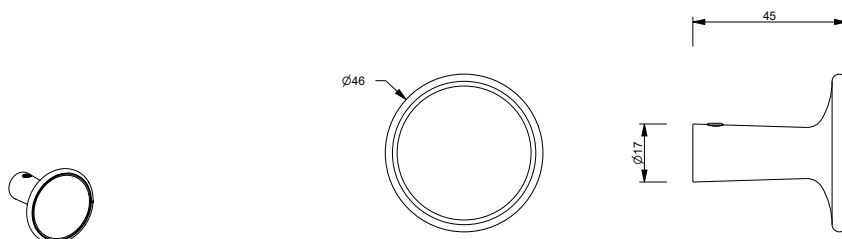

ART. H944

Appendiabiti / Robe hook / Patère / Haken / Colgador

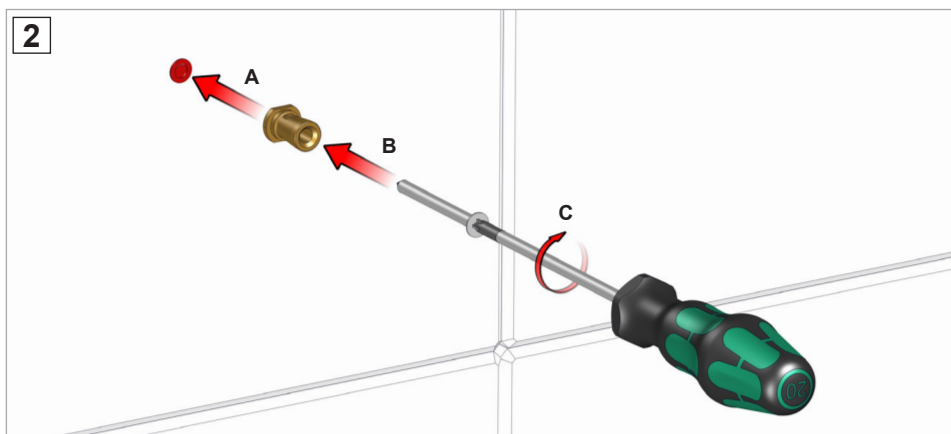
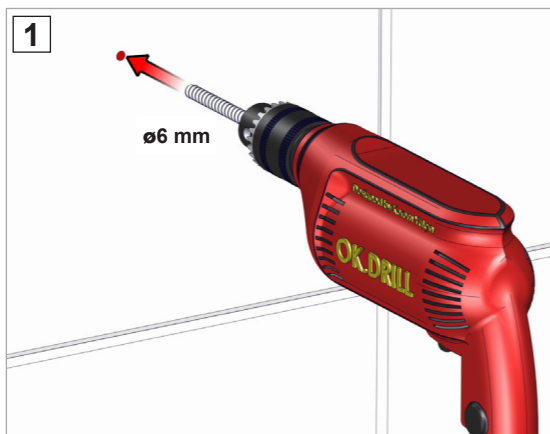

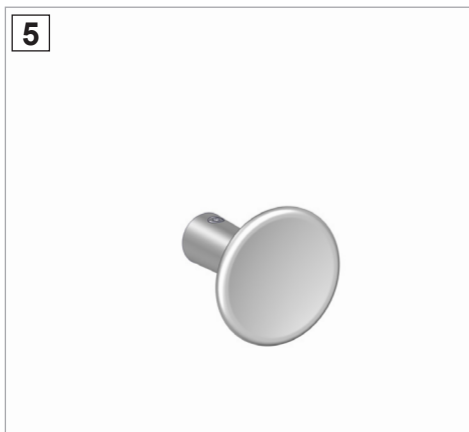
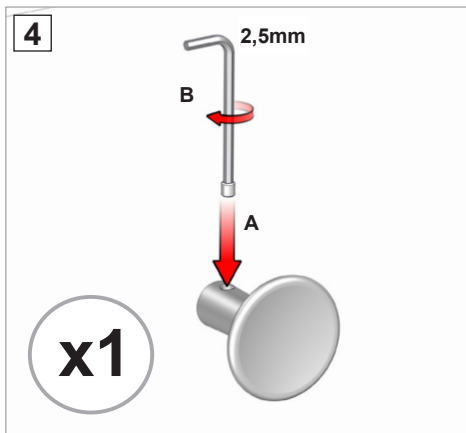
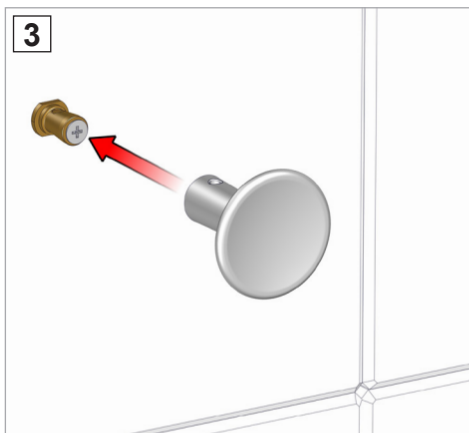

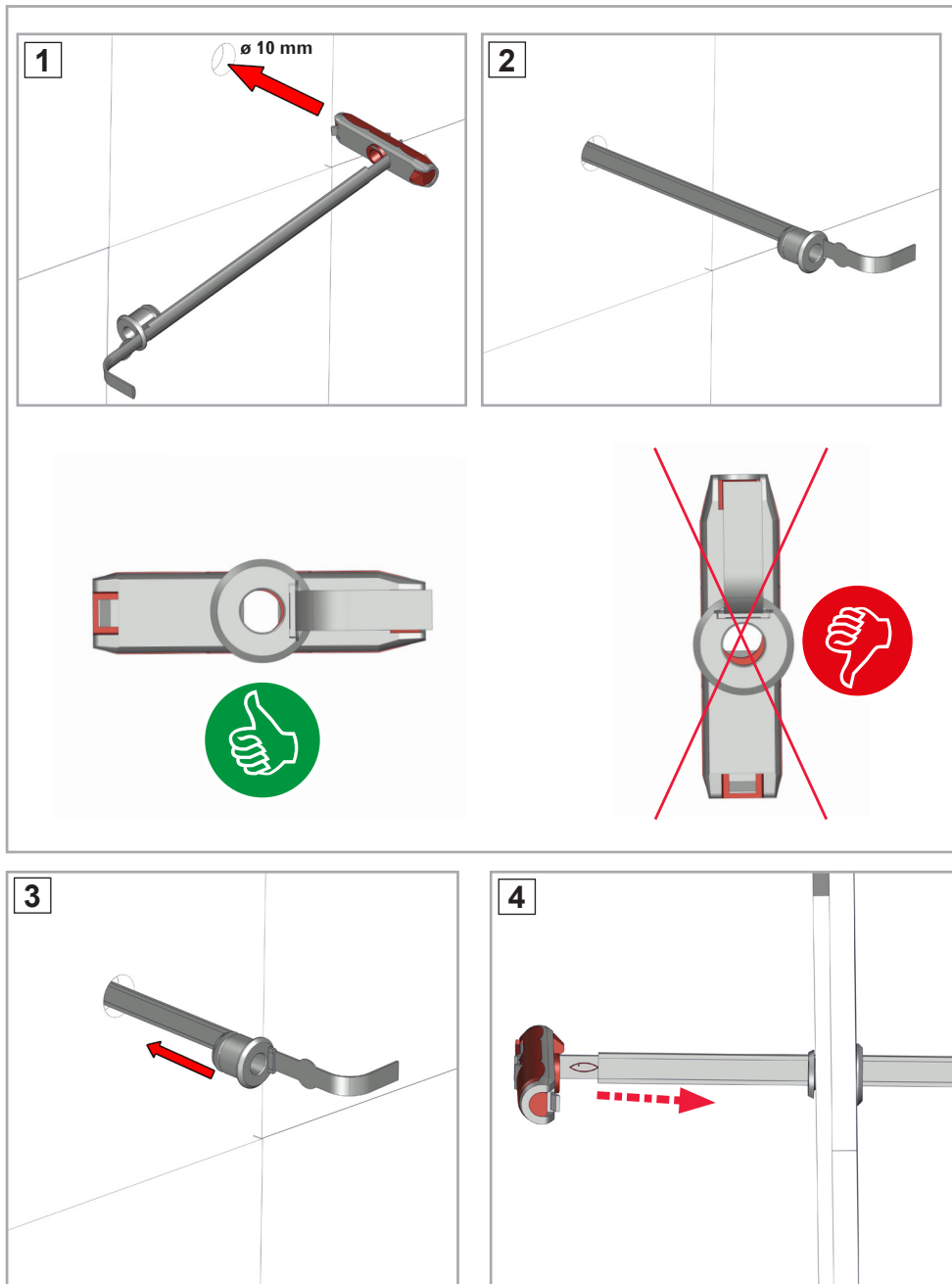

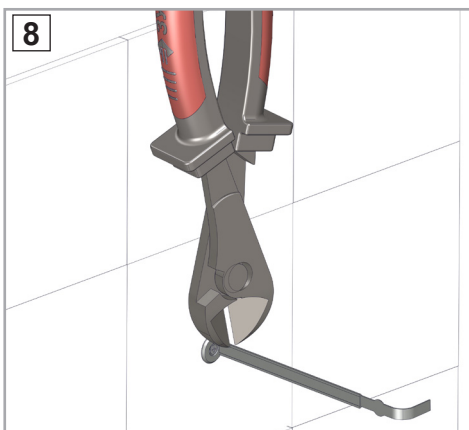
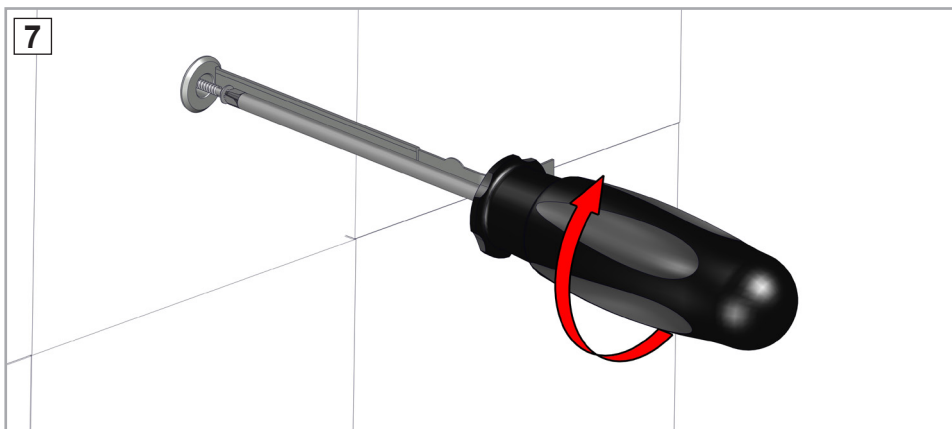
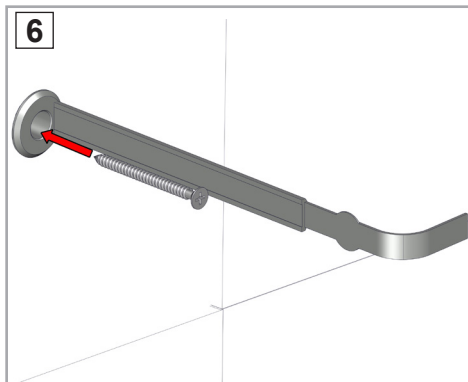
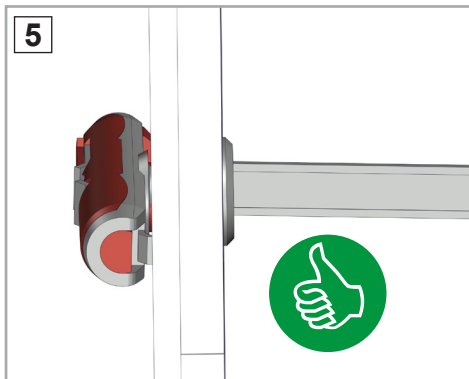



Fratelli Fantini Spa
via Buonarroti, 4
Pella (NO) Italia
T +39 0322 918411 r.a.
F +39 0322 969530
fantini@fantini.it
www.fantini.it



118300010000000 Rev. 0