

ART. 0512BU

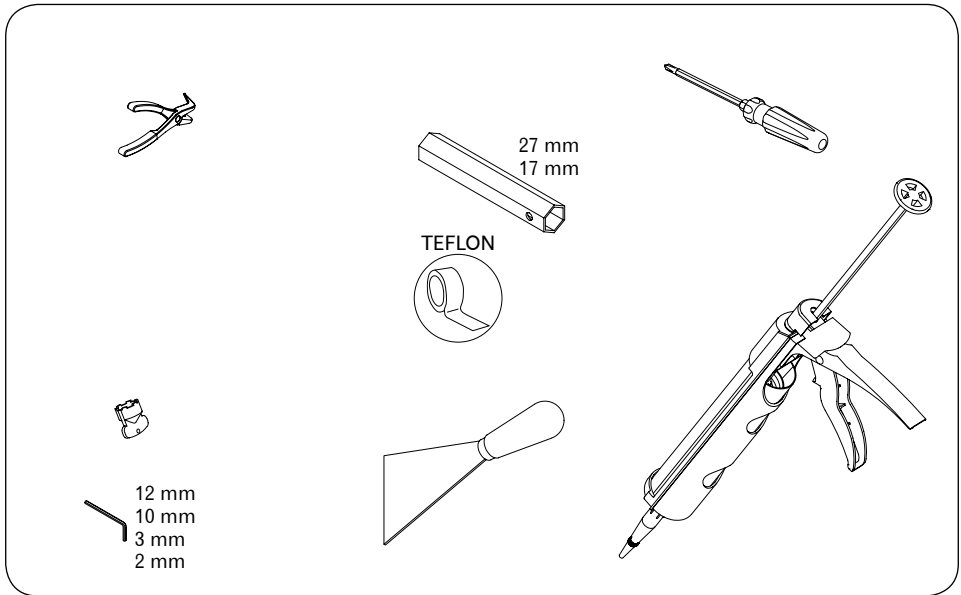

ART. 0545U

Tools needed / Instrumentos necesarios



Index / Índice

0512BU External pieces / Parte externa.....	4
Adjustments / Ajustes.....	6
Bolt replacement / Sustitucion rosca de extrusion.....	7
0545U Wall-mount spout / Caño a pared.....	8
Substitute aerator / Sustituir el aireador.....	10
Technical data / Datos Tènicos.....	12

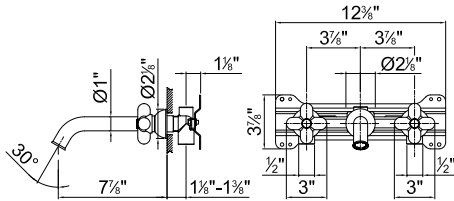
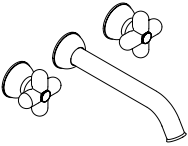

ART. 0512BU External pieces / Parte externa

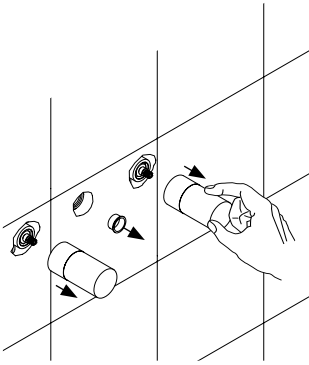

1.

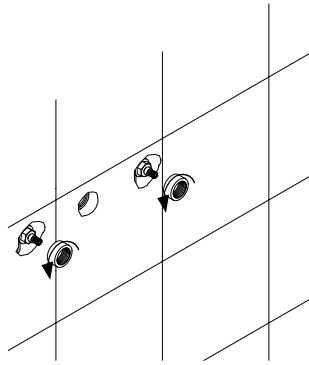

2.

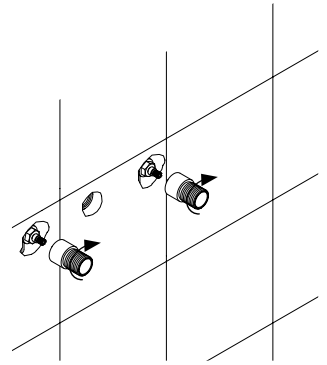

3.

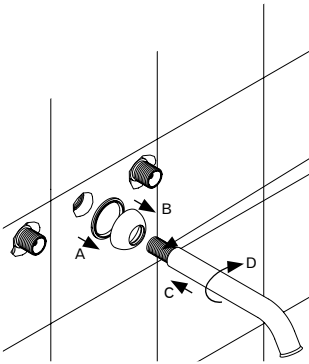

4.

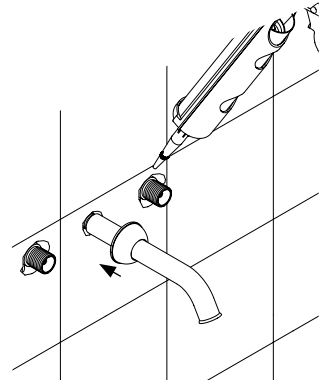

5.

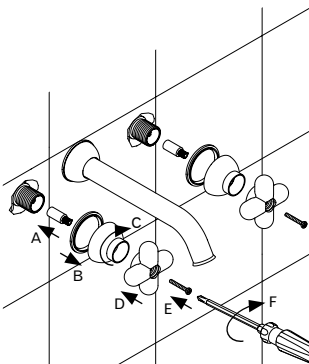

6.

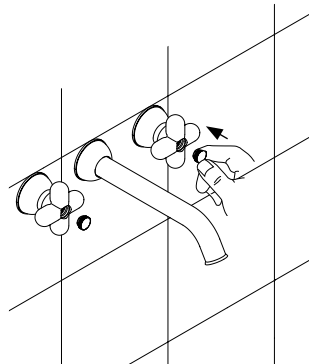

7.

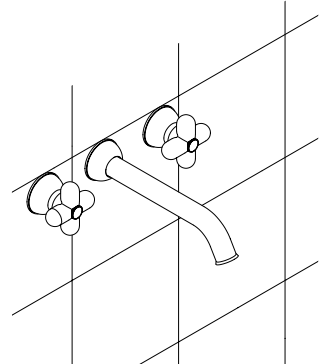

8.

Bolt Replacement / Sustitucion rosca de extrusion

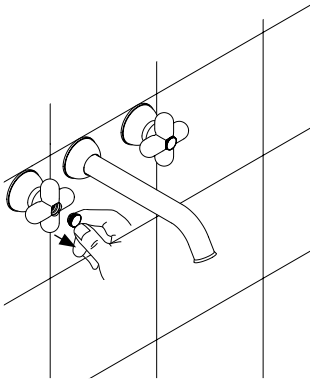

1.

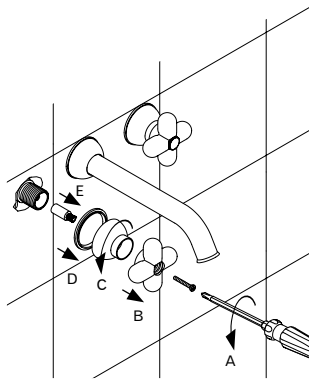

2.

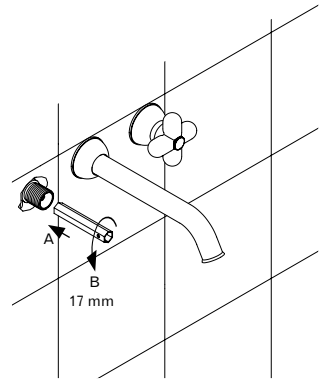

3.

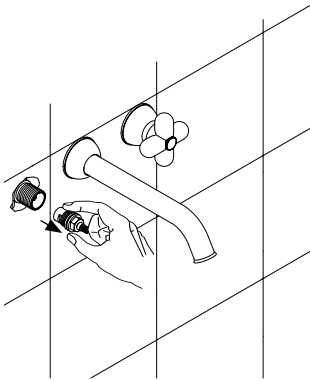

4.

Replace following the instructions in reverse order (4-3-2-1).
Colocar según el procedimiento inverso (4-3-2-1).

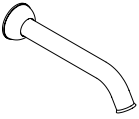

ART. 0545U

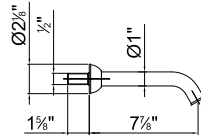

Wall-mount spout / Caño a pared

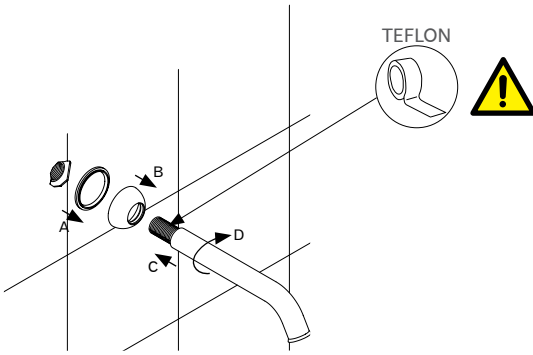

1.

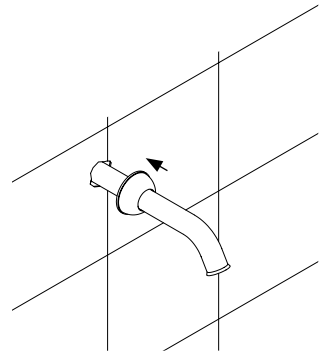

2.

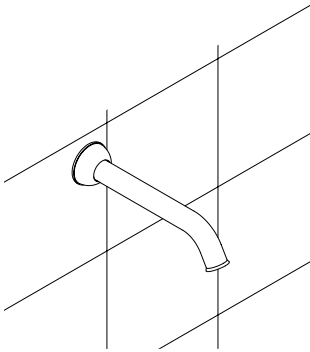

3.

Substitute aerator / Sustituir el aireador

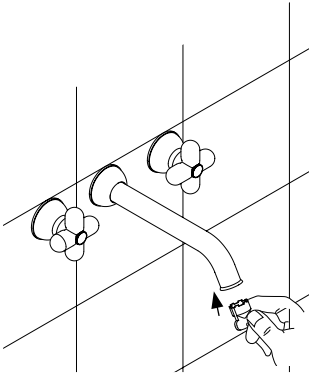

1.

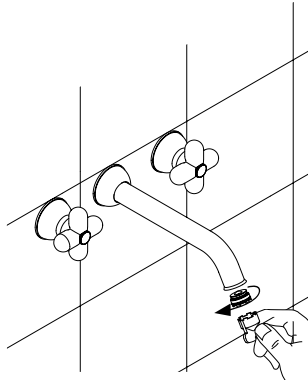

2.

- Replace following the instructions in reverse order (2-1)
- Colocar según el procedimiento inverso (2-1)

Technical data

Minimum pressure.....	14 PSI
Maximum pressure.....	145 PSI
Reccomended working pressure.....	30-70 PSI
Maximum water temperature.....	176°F
Maximum water temperature reccomended.....	150°F
Maximum in-let pressure difference (hot - cold).....	22 PSI

Operating instructions

These mixers can be used with cumulos boilers or instantaneous water heaters.

Warning

The supplying pipes must be carefully cleaned before installation.

Remember that the hot water supply must **ALWAYS** be connected to the tube on the **LEFT**.

ENGLAND.

Datos Técnicos

Presion mínima.....	14 PSI
Presion máxima.....	145 PSI
Presion de trabajo aconsejada.....	30-70 PSI
Temperatura máxima.....	176°F
Temperatura máxima aconsejada.....	150°F
Diferencial maxima de presiùn de entrada (caliente - fria).....	22 P

Aplicaciones

Estos monomandos pueden ser utilizados con acumuladores de agua caliente a presión.

Advertencias

Antes de conectar el monomando es necesario purgar correctamente la instalación hidráulica de alimentación de cualquier impureza que pueda tener.

Recuerde que el agua caliente debe ser **SIEMPRE** conectada al tubo o flexo de la **IZQUIERDA**.

SPAIN.

Advice on product care

To clean the surface use a soap and water solution.

Never use for any reason cleaning solutions containing abrasive substances, chloric acids, ammonia, vinegar, bleach, domestic acids, disinfectants, or anytype of abrasive pad.

WARNING! Incorrect cleaning may permanently ruin the surface of the products and in such case the manufacturer may not be held liable for damage.

The Manufacturer reserves the right to modify product and accessories at any time without prior notice. Datas, products and sketches included in this document are just for information and do not bind the producer.

ENGLAND.

Consejos para el cuidado del producto

La limpieza de las superficies se hace utilizando un jabón líquido diluido en agua.

No usar en ningún caso detergentes líquidos que contengan sustancias abrasivas ó a base de ácido clorhídrico, estropajos abrasivos, amoníaco, acetona, lejía, ácidos de uso doméstico, desinfectantes varios.

ATENCIÓN! El uso de productos desaconsejados puede danar irremediabilmente las superficies de los elementos, de lo cual el fabricante no se hará responsable en ningún caso.

La sociedad se reserva el derecho de modificar sus productos y accesorios en cualquier momento y sin previo aviso.

SPAIN.

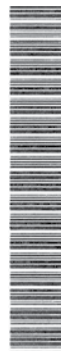

Disegni e grafica: www.dipi-designs.com

1160000300000U Rev. 1