

## Electrical rope winch WIRELESS

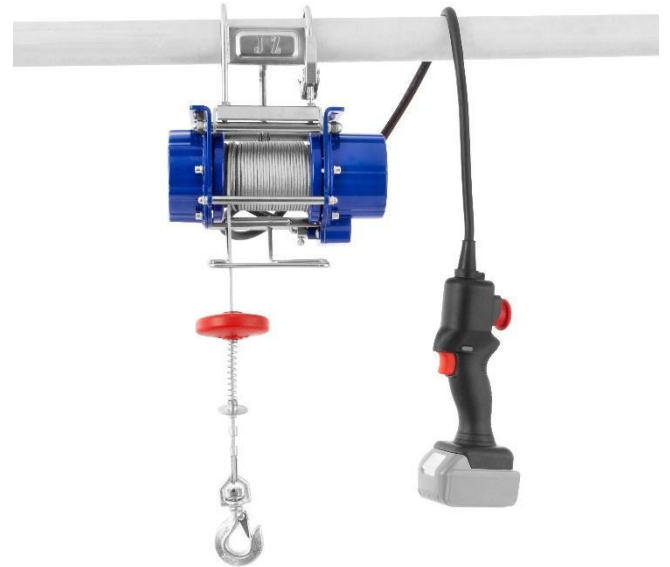

### Why the electrical rope winch WIRELESS

This electric wire rope winch is suitable for fast, safe lifting and lowering of all types of loads. It is used in workshops, warehouses or the private sector. The load capacity of the electric rope winch can be duplicated by attaching a double hook.

- Max. **lifting speed**: Up to 8 m/min (single hook) and up to 4 m/min (double hook)
- An **emergency stop switch** shuts off the device immediately in case of danger
- **Extra long control cable** (5 m) for remote control

- **Safe operation**: remote control, emergency stop switch and cable sheathing made of rubber
- The powerful motor is equipped with an **overheating protection** device
- This rope winch is equipped with a **12m long steel rope**
- The electric rope winch is protected against **dust and splash water according to IP54** and complies with **EN-14492-2**

# Technical data

## WIRELESS

### DIMENSIONS

Cable length remote control	1.6 m
Single hook lifting height	12 m
Power cable length	0.45 m
Rope diameter	3.5 mm
Length of rope	12 m
Smallest distance (mounting to end of hook)	620 mm

### GENERAL INFORMATION

Standard	EN 14492-2
Colour	Ultramarine blue
Material	Steel
Design	Electrical rope winch
Weight	10 kg

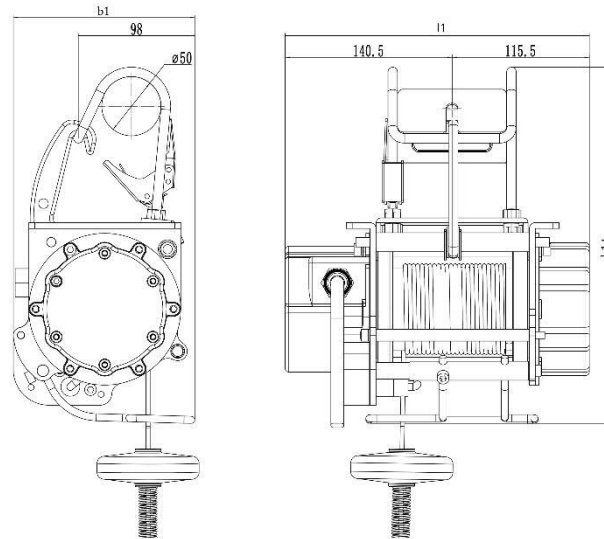

### TECHNICAL SPECIFICATIONS

Protection class	IP 54
Thermal overload protection	Yes
Noise level	71 db
Distance of drill holes lengthwise	160 mm
Distance of drill holes across	90 mm
Single hook lifting speed	4 m/min
Single hook load capacity	200 kg
Appliance voltage	230 V
Motor output	320 W
Insulation class	B
Duty cycle	S3-20%-10, S3-25%-10
Thread size	M10
Rope tensile strength	1870 N/mm <sup>2</sup>
Battery type	18V 6Ah
Engine group	M1

We are improving our products continuously. It is therefore possible that technical data changes without prior notice. Product image and drawings can deviate depending on design and year of manufacture, .

## Images

WIRELESS



## Why Pallit?

- Delivery free of charge within 1-3 workdays
- 100 days right of return
- Five year basic warranty for all platform trolleys
- Live-long first aid in case of technical questions
- On-site repair service available



Questions? Contact our product experts.

☎ 0800 - 000 96 25