

Electric high lift truck UP20



Why UP20?

The Pallit UP20 is an all-electric professional high lift pallet truck and enables two pallets to be picked up at the same time. The model can stack loads up to 2000 kg or load and unload trucks. The UP20 is designed for continuous daily use and is suitable for industrial applications.

- **Three options** to choose from: The UP20 is available with lifting heights of 1.6 m, 2 m, 2.5 m
- **Initial lift:** Dual pallet transport, as well as passing over door thresholds
- **210 Ah** strong lead battery for intensive use

- **Polyurethane (PU) tires:** quiet and stable operation
- The **Single tires** make it easier to pick up pallets crosswise
- **Small turning radius** for working in tight spaces
- Strong and powerful - even in the long run: That's why we offer our **Plus warranty for 5 years**

Technical data

Electrical high lift truck UP20

OPTIONS Choose between

① | ② | ③

Lifting height	1.6 m 2 m 2.5 m
Max. height:	2118 2508 3018 mm
Min. total height	1082 1212 1382 mm
Weight	950 950 950 kg

DIMENSIONS

Fork length	1100 mm	l
Width	775 mm	b1
Length	1962 mm	l1
Outer fork with	570 mm	b5
Ground clearance	20 mm	m ²
Distance between forks	210 mm	
Height from ground	90 mm	h13
Height of drawbar	1300 mm	h14
Individual fork width	180 mm	e
Centre of gravity	600 mm	c
Turning radius	1705 mm	
Min. aisle width (EPAL1 euro-pallet)	2288 mm	Ast

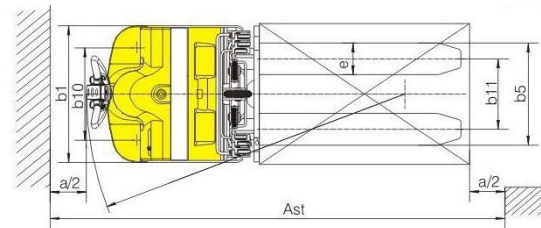
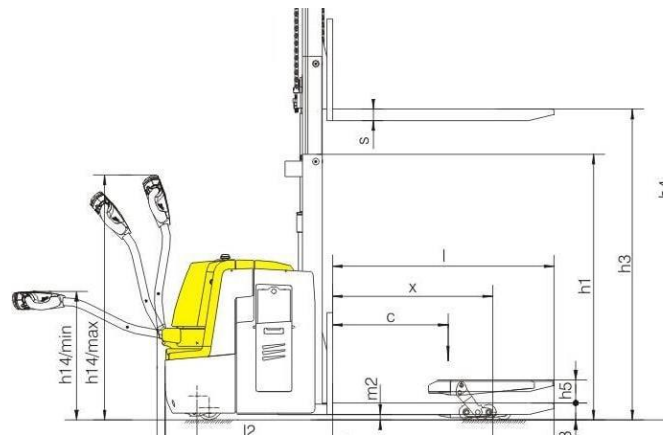

GENERAL INFORMATION

Load capacity	2000 kg
Type of drive	Electrical
Material	Steel
Drive speed unloaded	5.2 km/h
Type of brakes	Electromagnetic
Sound pressure level according to EN 12053	65 db(A)

BATTERY

Battery type	Led battery
Battery weight	196 kg
Battery capacity	210 Ah
Operating period	6 h
Battery voltage	24 V
Battery level display	Yes
Charger	External, included

LIFT

Lifting type	Electrical hydraulic
Lifting speed, unloaded	0.04 m/s
Motor output, lift	1.2 kW

TYRES

Material of tyres	Polyurethane (PU)
Casters	Tandem
Width of casters	70 mm
Diameter of casters	80 mm
Width of swivel casters	70 mm
Diameter of casters	250 mm

We are improving our products continuously. It is therefore possible that technical data changes without prior notice. Excluded from our manufacturer's warranty "Plus-Guarantee" are wear parts, rechargeable batteries and power packs - details can be found in our warranty declaration. The platform trolley complies with the EC Safety regulations.

Images

Electrical high lift truck UP20



Images

Electrical high lift truck UP20



Why Pallit?

- Delivery free of charge within 1-3 workdays
- 100 days right of return
- Live-long first aid in case of technical questions
- On-site repair service available



Questions? Contact our product experts.

☎ 0800 - 000 96 25