

Electric high lift truck DOUBLE-S



Why DOUBLE-S?

This electric high lift truck with initial lift is best suited for easy movement of goods over ramps and uneven floors, simplifying your daily work. With innovative technology and initial lift, this affordable electric high lift truck is ideally suited to achieve fast and efficient goods handling.

- Due to **initial lift**, there is the option of **increased ground clearance** for the trouble-free transport of loads over loading ramps and more
- With its **small turning radius of 1450 mm**, the machine is also ideally suited for narrow warehouse aisles
- The max. travel speed of 4.5 km/h (loaded) is optimally suited for

temporary use in logistics, warehousing and commerce

- Powerful 105 Ah strong **gel battery**
- The **energy level indicator** provides a constant overview of the remaining battery runtime
- Wear-free braking of the lift truck thanks to **electromagnetic braking system**
- **Highest safety standards** due to safety and emergency stop switch as well as rounded transport forks

Technical data

Electric high lift truck DOUBLE-S

OPTIONS Choose between

	1	2
Load capacity	1000 kg	1200 kg
Lifting height	2.5 m 3.3 m	3.0 m
Max. height:	3092 3892 mm	3592 mm
Min. total height	1872 2272 mm	2122 mm
Effective lift	2410 3210 mm	2910 mm
Weight	670 702 kg	760 kg

DIMENSIONS

Fork length	1150 mm	l
Width	800 mm	b1
Length	1789 mm	l1
Outer fork with	570 mm	b5
Ground clearance	17 mm	m ²
Distance between forks	210 mm	
Height from ground	90 mm	h13
Height of drawbar	1300 mm	h14
Individual fork width	160 mm	e
Centre of gravity	600 mm	c

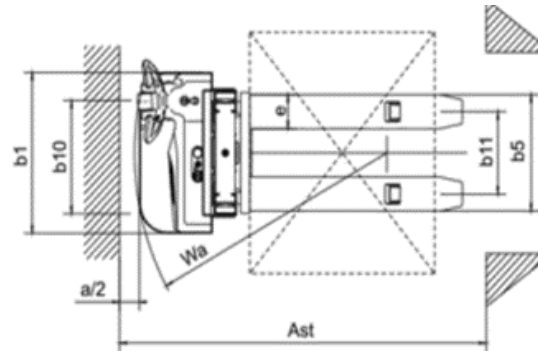
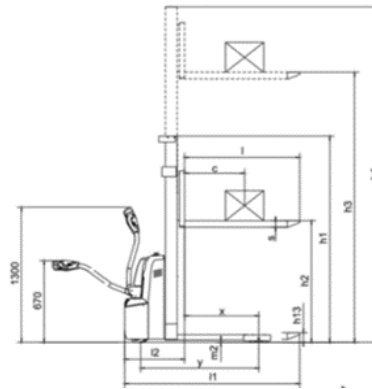

GENERAL INFORMATION

Material	Steel
Driving distance	Average distance
Sound pressure level according to EN 12053	70 db(A)
Forklift license	No
Chassis surface	Powder-coated

BATTERY

Battery type	Gel
Battery weight	60.8 kg
Battery capacity	105 Ah
Operating period	5 h
Ladezeit	7 h
Battery voltage	12 V
Number of batteries	2

LIFT

Lifting type	Electrical hydraulic	
Initial lifting height	120 mm	h5
Motor output	2.2 kW	

TYRES

Material of tyres	Polyurethane (PU)
Fork rolls	Tandem
Width of casters	70 mm
Diameter of casters	80 mm
Width of swivel casters	70 mm
Diameter of casters	195 mm

We are improving our products continuously. It is therefore possible that technical data changes without prior notice. Product image and drawings can deviate depending on design and year of manufacture. Details to our manufacturer "Plus warranty" available under Declaration of warranty. The platform trolley complies with the EC Safety regulations.

Images

Electric high lift truck DOUBLE-S



Images

Electric high lift truck DOUBLE-S



Why Pallit?

- Delivery free of charge within 1-3 workdays
- 100 days right of return
- Five year basic warranty for all platform trolleys
- Live-long first aid in case of technical questions
- On-site repair service available



Questions? Contact our product experts.

☎ 0800 - 000 96 25