

Electric lifting truck ONE-S



Why the ONE-S?

The ONE-S simplifies daily work in the logistics industry. Due to its low tare weight of 115 kg, it can easily be taken along on a truck. The high battery efficiency enables optimal in-house transport of goods. **The high battery efficiency enables optimal in-house transport of goods.**

- **Easy handling** facilitates battery replacement, which is removed in one easy step and without any additional tools
- Fast goods handling, due to **high driving speed** of loaded/unloaded: 4.3 km/h / 4.8 km/h
- **Multi-shift operation is possible** with an exchangeable battery (available separately)

- **Strong readiness:** operating time of 3 h without the need for a replacement battery
- Versatile use of the lithium pallet truck in warehouses, in distribution centres, in wholesale and retail, in production as well as in the forwarding and logistics industry
- Due to the emergency stop switch, the pallet truck can be stopped at any time - **extra safe**
- The **lithium-ion battery** with 24 V / 20 Ah power is completely maintenance-free

Technical data

Electric lifting truck ONE+S

DIMENSIONS

Fork length	1150 mm	
Width	550 mm	b1
Length	1580 mm	l1
Outer fork width	550 mm	b5
Wheel base	1152 mm	y
Ground clearance	33 mm	m ²
Distance between forks	230 mm	
Height from ground	80 mm	h13
Height of drawbar	1200 mm	h14
Individual fork width	160 mm	e
Centre of gravity	600 mm	c
Turning radius	1380 mm	Wa
Min. aisle width (EPAL1 Euro pallets)	2050 mm	Ast

GENERAL INFORMATION

Load capacity	1500 kg
Material	Steel
Weight	115 kg
Type of brakes	Electrical
Sound pressure level according to EN 12053	70 db(A)

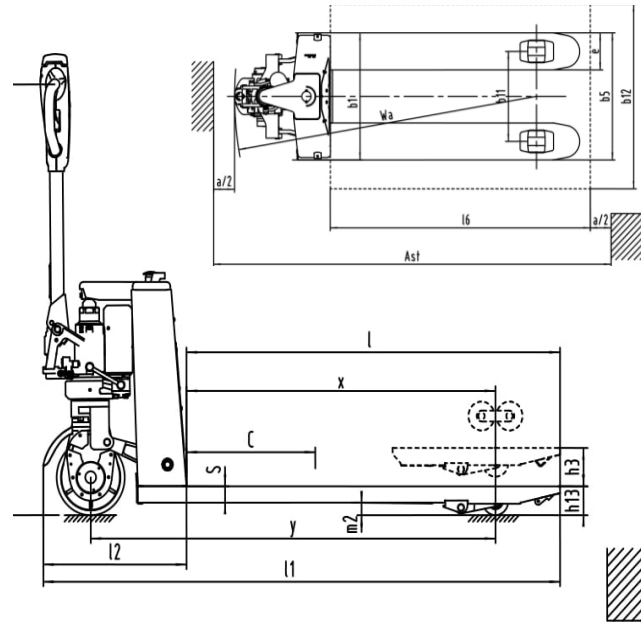

Drive

Type of drive	Electrical
Rising capacity, unloaded	20 %
Rising capacity, loaded	5 %
Motor output	0.75 kW
Drive speed loaded	4.3 km/h
Drive speed unloaded	4.8 km/h

BATTERY

Battery type	Lithium-ion
Operating period	3 h
Charging time	3 h

Battery weight	5.5 kg
Battery capacity	20 Ah
Battery voltage	24 V
Number of batteries	1
Charger	External, included

Lift

Lifting height (h3)	110 mm
Lift type	Electrical hydraulic
Lifting speed, loaded	0.016 m/s
Lifting speed, unloaded	0.02 m/s
Motor output	0.58 kW

TYRES

Material of tyres	Polyurethane (PU)
Casters	Tandem
Width of casters	70 mm
Diameter of casters	80 mm
Width of swivel casters	70 mm
Diameter of casters	210 mm
Intake rollers	Yes

We are improving our products continuously. It is therefore possible that technical data changes without prior notice. Details to our manufacturer warranty available under Declaration of warranty. The platform trolley complies with the EC Safety regulations.

Images

Electric lifting truck ONE+S



Images

Electric lifting truck ONE+S



Why Pallit?

- Delivery free of charge within 1-3 workdays
- 100 days right of return
- Five year basic warranty for all platform trolleys
- Live-long first aid in case of technical questions
- On-site repair service available



Questions? Contact our product experts.

☎ 0800 - 000 96 25