

## Electric lifting truck ONE-XS



### Why the ONE-XS?

The ONE-XS electric pallet truck is designed for daily transport work with Euro pallets and Euro mesh boxes. It is characterised by its powerful lithium battery, which can be charged in a short time and can also be charged temporarily. The low dead weight of 125 kg predestines it for being taken along in the truck.

- **Easy handling** when charging the battery with only one handle and without additional tools.
- Fast goods handling, due to high **driving speed** of loaded / unloaded: 4 km/h / 5 km/h
- **High load capacity**: the pallet truck has a maximum load capacity of 1500kg
- Versatile **usage** of the lithium pallet truck in warehouses, in distribution centres, in wholesale and retail, in production as well as in the forwarding and logistics industry
- Due to the electronic ignition lock, the pallet truck is **extra safe**
- The **lithium-ion battery** with 48 V / 10 Ah power is completely maintenance-free
- With **battery level indicator** for information on the charge level

## Technical data

### Electric lifting truck ONE-XS

#### DIMENSIONS

Fork length	1150 mm	l
Width	550 mm	b1
Length	1552 mm	l1
Outer fork width	550 mm	b5
Ground clearance	33 mm	m2
Distance between forks	230 mm	
Height from ground	85 mm	h13
Height of drawbar	1276 mm	h14
Individual fork width	160 mm	e
Centre of gravity	600 mm	c
Turning radius	1353 mm	Wa
Min. aisle width (EPAL1 Euro pallets)	1687 mm	Ast

#### GENERAL INFORMATION

Load capacity	1500 kg
Weight	125 kg
Type of brakes	Electromagnetic
Sound pressure level according to EN 12053	70 db(A)

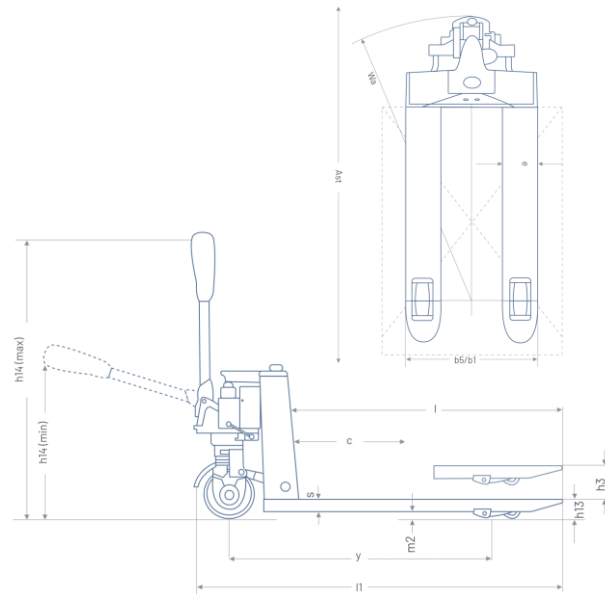

#### Drive

Type of drive	Electrical
Rising capacity, unloaded	20 %
Rising capacity, loaded	6 %
Motor output	0.75 kW
Drive speed loaded	4 km/h
Drive speed unloaded	5 km/h

#### BATTERY

Battery type	Lithium-ion
Operating period	3 h
Charging time	5 h

Battery weight	5.5 kg
Battery capacity	10 Ah
Battery voltage	48 V
Battery level display	Yes
Number of batteries	1
Charger	External, included

#### Lift

Lifting height (h3)	200 mm
Lift type	Electrical hydraulic
Lifting speed, loaded	0.03 m/s
Lifting speed, unloaded	0.035 m/s
Motor output	0.5 kW

#### TYRES

Material of tyres	Polyurethane (PU)
Casters	Tandem
Width of casters	70 mm
Diameter of casters	80 mm
Width of swivel casters	55 mm
Diameter of casters	140 mm
Intake rollers	No

We are improving our products continuously. It is therefore possible that technical data changes without prior notice. Details to our manufacturer warranty available under Declaration of warranty. The platform trolley complies with the EC Safety regulations.

## Images

Electric lifting truck ONE-XS

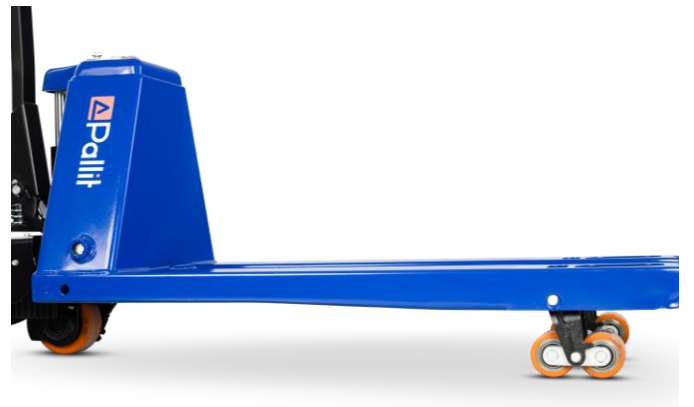

## Images

Electric lifting truck ONE-XS



## Why Pallit?

- Delivery free of charge within 1-3 workdays
- 100 days right of return
- Five year basic warranty for all platform trolleys
- Live-long first aid in case of technical questions
- On-site repair service available



Questions? Contact our product experts.

☎ 0800 - 000 96 25