



NEW PRODUCT

Announcement Number: S07301901

PERFECT FOR DIESEL AND HEMI V8

High-Pressure Reprogramming Kit™

TUNELESS!

Fits All RFEs 1999-18 PATENT PENDING

PART# **RFE-7B-HP** (1999-2010) **7-checkball VB**

PART# **RFE-5B-HP** (2011-2018) **5-checkball VB**

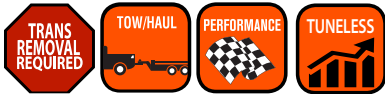
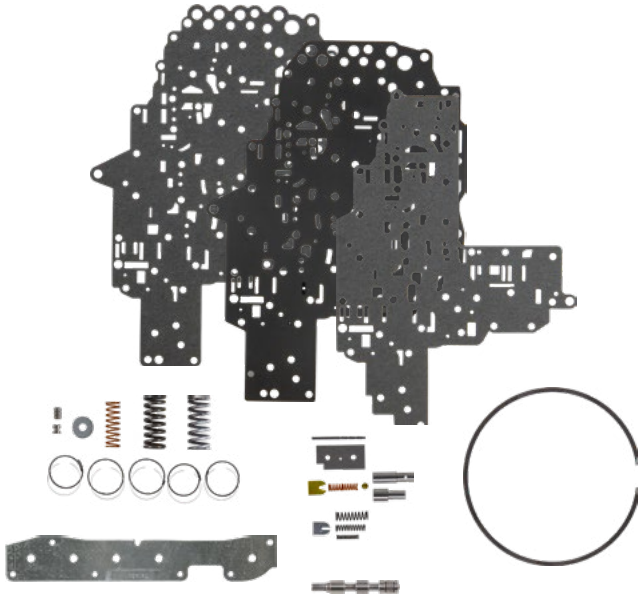

RFE High-Pressure Reprogramming™ Kits

Built for performance and designed for durability, TransGo **Tuneless Technology** high-pressure kits are compatible with all 45/5-45/65/66/68 RFE transmissions and include everything you need to internally reprogram a more robust transmission, capable of handling today's aftermarket engine performance additions, such as tuners, chips or programmers.

The new RFE high-pressure kits allow increased engine horsepower and torque via aftermarket tuners and other mods **without the driveability side effects and costs** associated with external transmission PCM programming. Included with the many performance and tow upgrades is an optional triple-disc converter calibration valve, for use with triple-disc converters to modulate the apply rate of the converter clutch, preventing harsh lockup engagement complaints without diminishing increased holding power benefits.

High pressure without side effects

A re-engineered torque converter max pressure limit system prevents over-pressurization/ballooning in lockup without effecting TCC apply feel. Re-calibrated line pressure curve mirrors driver throttle position and torque demand, delivering shorter, cleaner shifts at all throttle openings without harsh or erratic shift feel and/or bind-ups.

These patent-pending internally balanced calibrations provide progressive and seamless clutch-to-clutch apply pressure increases to 210 psi max, a **30% increase** over the OEM 160 psi max.

High-Pressure Reprogramming™ Kit includes: TransGo® patent-pending components

- Re-calibrated converter and pressure regulator systems
- Re-engineered torque converter limit system
- Triple separator plate with gaskets
- Triple-disc converter calibration valve

Additional components

- Heavy duty accumulator plate
- Heavy duty snap ring for input drum
- Accumulator calibration components

OPTIONAL UPGRADE SOLD SEPARATELY



PART#: RFE-PP-ODHP

Fits all RFE 1999-2018

Hot-forged 1045 steel fully CNC'd overdrive pressure plate allows the addition of extra capacity to the OD stack

For even greater overdrive clutch capacity, TransGo offers an optional hot-forged 1045 steel fully CNC'd overdrive pressure plate (**part #RFE-PP-ODHP** sold separately) allowing the addition of extra capacity to the OD stack in all models.

Corrects, Prevents, Reduces

- Friction failure when combined with aftermarket engine performance add-ons
- Soft, slipping or erratic shifting
- Over pressurization/ ballooning of the torque converter
- Harsh triple-disc converter apply

**ENGINEERED FOR PERFORMANCE.
DESIGNED FOR DURABILITY.**

©TransGo. All rights reserved. TransGo®, Shift Kit®, SK® and Reprogramming Kit™ are registered and licensed trademarks.



Tech Support 626.443.7451



techinfo@transgo.com