



340-HD2

Reprogramming Kit™

Fits: 1987-2007 4 Speed Toyota 340, 341, 343 & Jeep AW4.

Street, Strip & Off Road

Increases Clutch Plate durability. Provides short-firm shifts, Perfect for Hot Rods & Trucks. Trans will stay in low gear with Lever in manual low position.

Installs with trans in vehicle.

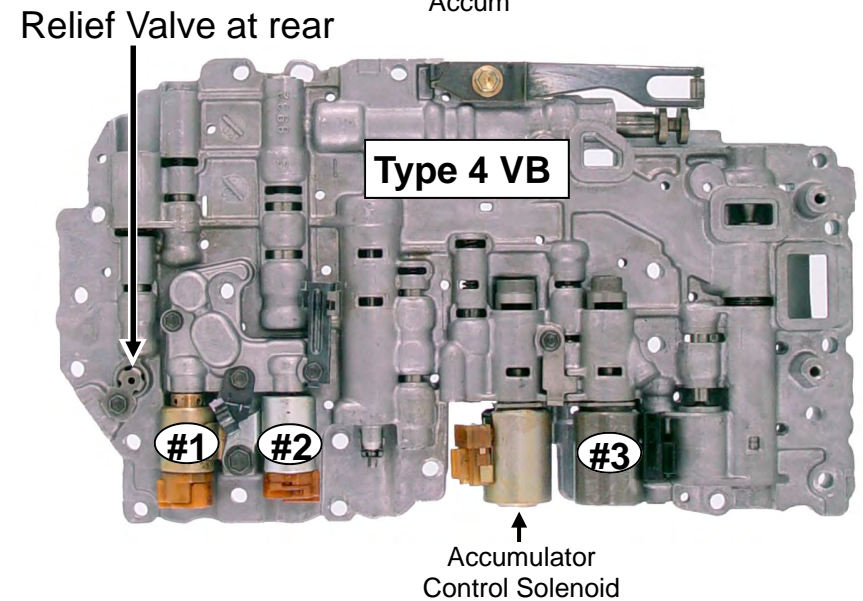
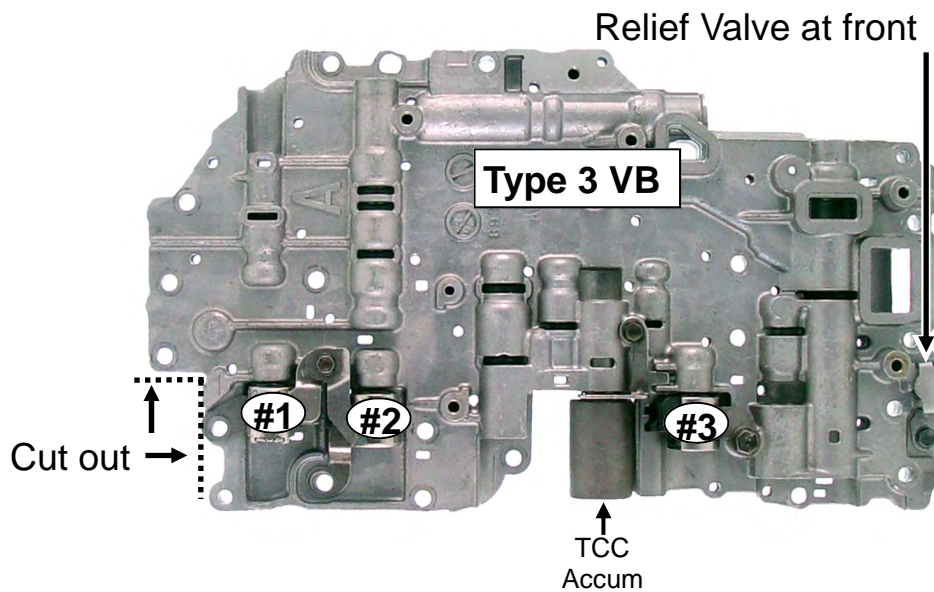
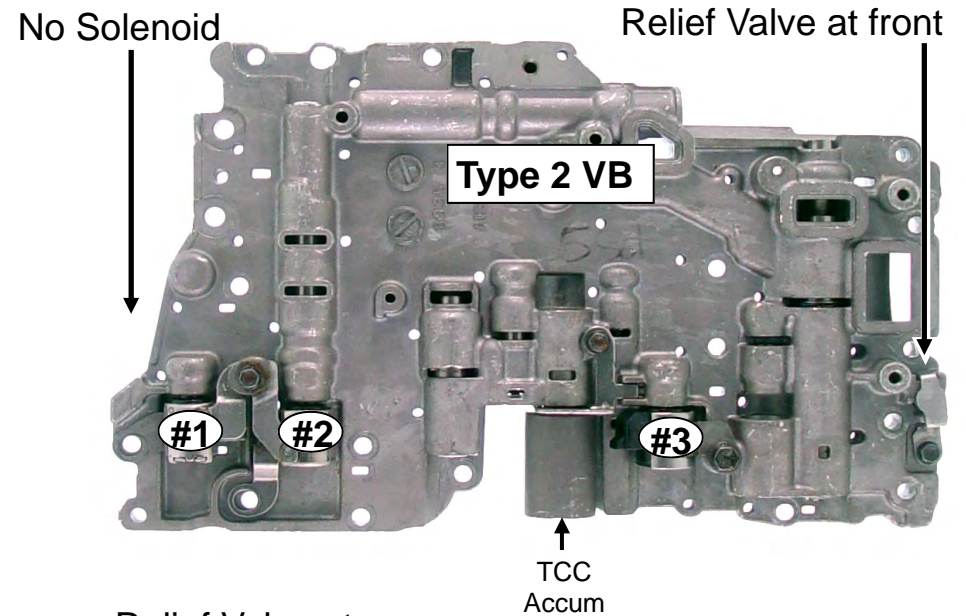
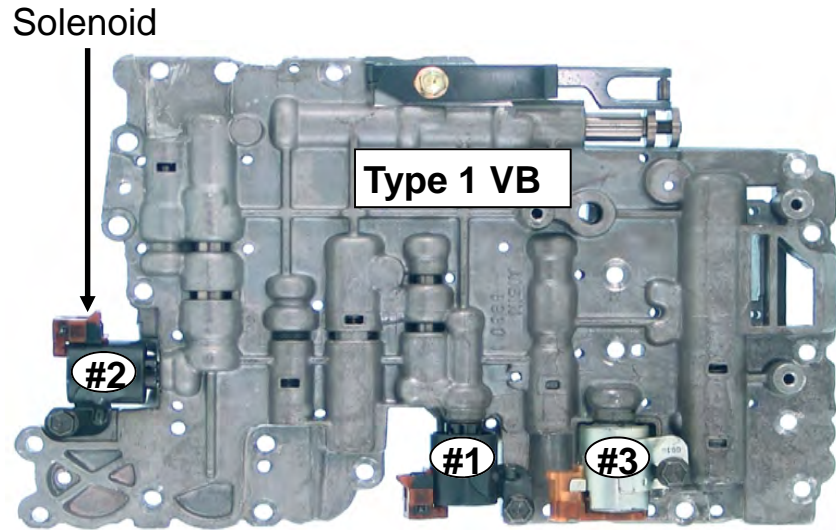
Professional installation is strongly recommended

STOP! Read This! You will need valve body gaskets that fit the **exact** model you are working on. Currently there are 17 different gaskets! If you are unable to procure gaskets for your model, we have a complete VB gasket set available as a kit that covers all. They can not be sold individually. The part number is 340-VB-G to order, call 626-443-7451.

Identify Valve Body.

Select instructions for Valve Body type.
Four Valve body instructions are included.

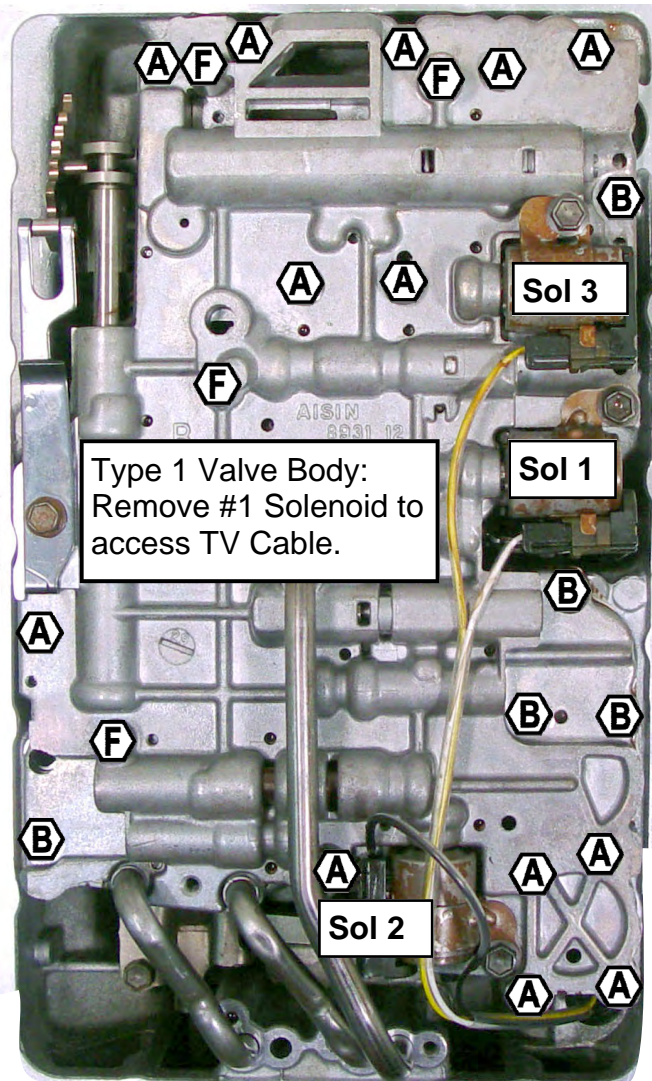
Follow the instructions in this guide for: Valve Body removal & disassembly, VB assembly, Accumulator and VB installation for ALL Valve Body types. Note: Type 1 VB is shown as an example, Bolt length will vary with other Valve Bodies.



Valve Body Removal & disassembly for ALL Valve Body types. READ entire page before beginning. Type 1 Valve Body shown as reference.

Step 1

Remove Filter & unplug Solenoids (note wire color and location first)



← **F** Filter Bolts
A **B** Valve Body Bolts

Step 2 Cable type

Pull TV Cam with hooked Scribe & disconnect TV Cable from Cam.



Type 1 Valve Body:
 Remove #1 Solenoid to
 access TV Cable.

READ! VB shown is type 1. VB to Case Bolt location is the same for ALL VB types. Bolt *length* varies between VB types. Type 3&4 VB does not use Tubes. Solenoid layout is different for types 2,3 & 4. The Bolts that hold the VB Halves together vary between VB types. Take your time and **be alert** to assure success.

Step 4

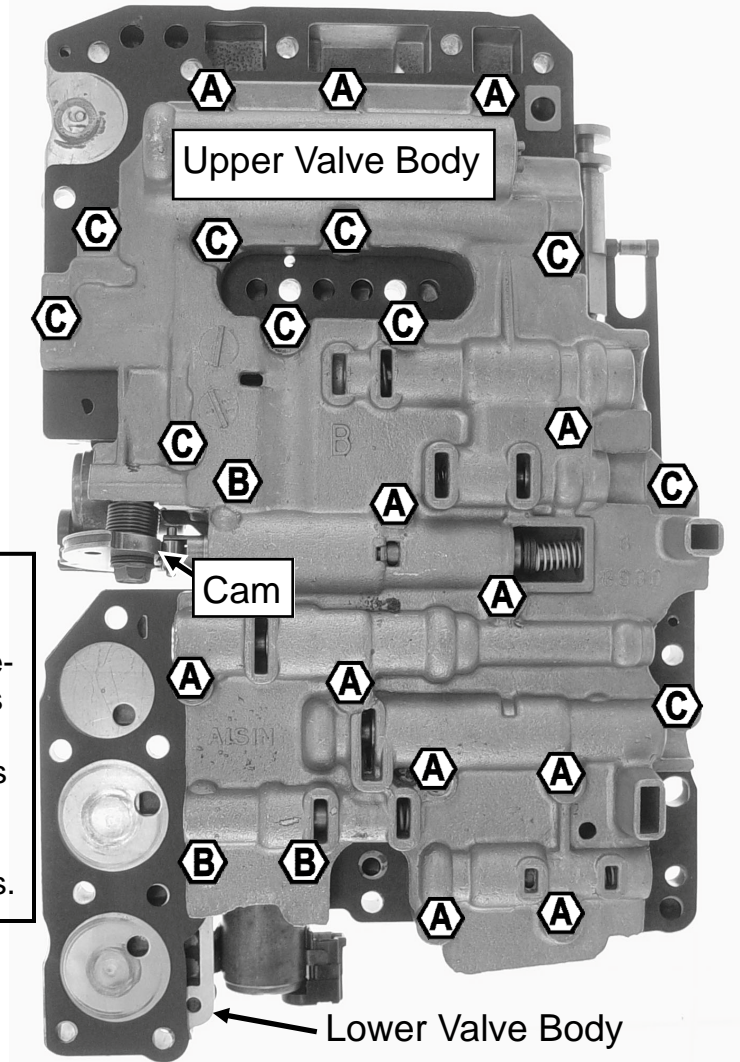
Remove Valve Body Bolts and Valve Body.

Step 3

Note position & Remove Tubes if equipped.

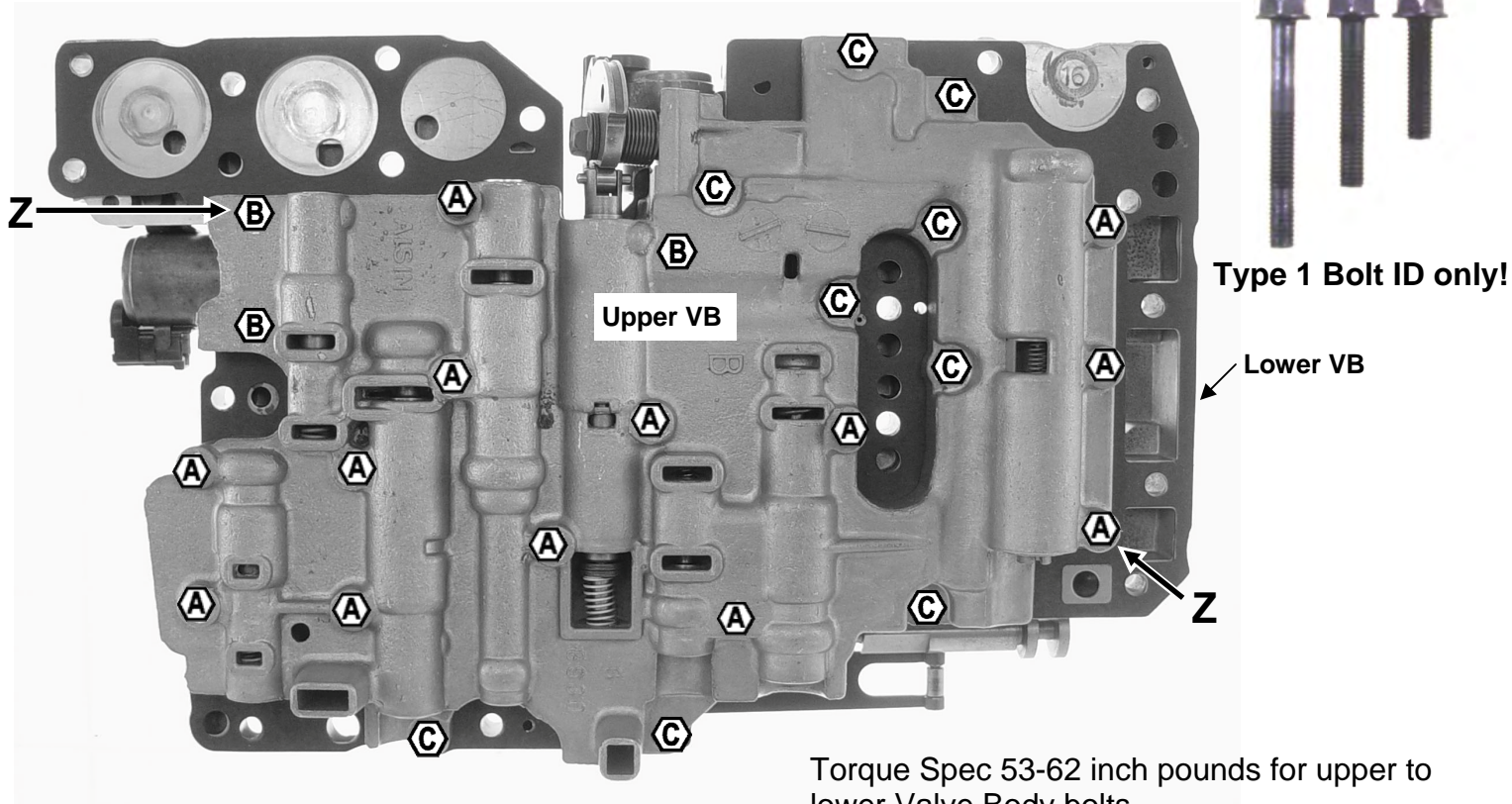
Step 5

Remove Valve Body Bolts, Carefully lift Separator Plate and upper Valve Body off the lower Valve Body together so the small Parts stay in place. Turn upper Valve Body & Plate over together, remove Separator Plate from upper Valve Body & look closely for check Ball and Retainer locations in upper & lower Valve Body.



Valve Body Assembly

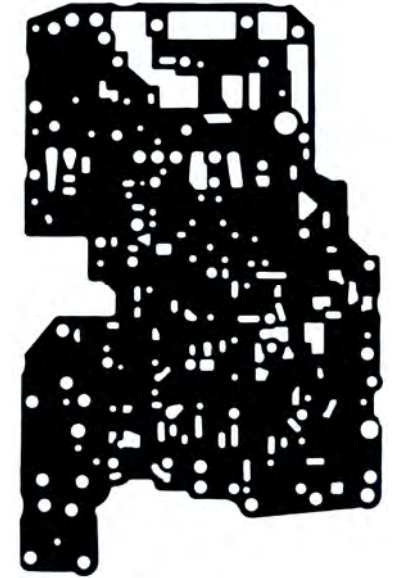
- 1) Secure Retainers, Balls & Filters in upper & lower Valve body with Trans assembly lube or petroleum jelly. *Do not use Grease, it won't melt!*
- 2) Match new Valve Body gaskets to old ones, new gaskets must not cover any holes in Plate. *Type 1 VB has 3 different sets of Gaskets-check carefully.* Paste VB Gaskets on *correct side* of separator Plate with Trans assembly lube.
- 3) Place lower VB on the Bench & align the separator Plate on lower Valve Body.
- 4) Align upper Valve Body on top of Separator Plate. Push down on upper VB to compress bypass Spring in lower VB, Start & tighten "Z" Bolts first.
- 5) Following Bolt guide install & tighten the remaining Bolts.
Careful, Threads strip easily. Use Nut driver to tighten VB Bolts.



Torque Spec 53-62 inch pounds for upper to lower Valve Body bolts.

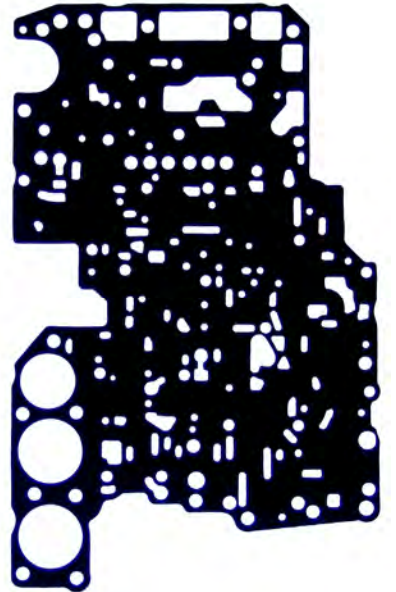
Valve Body to Case bolts 80-89 inch pounds.

Plate to **lower** Valve Body Gasket

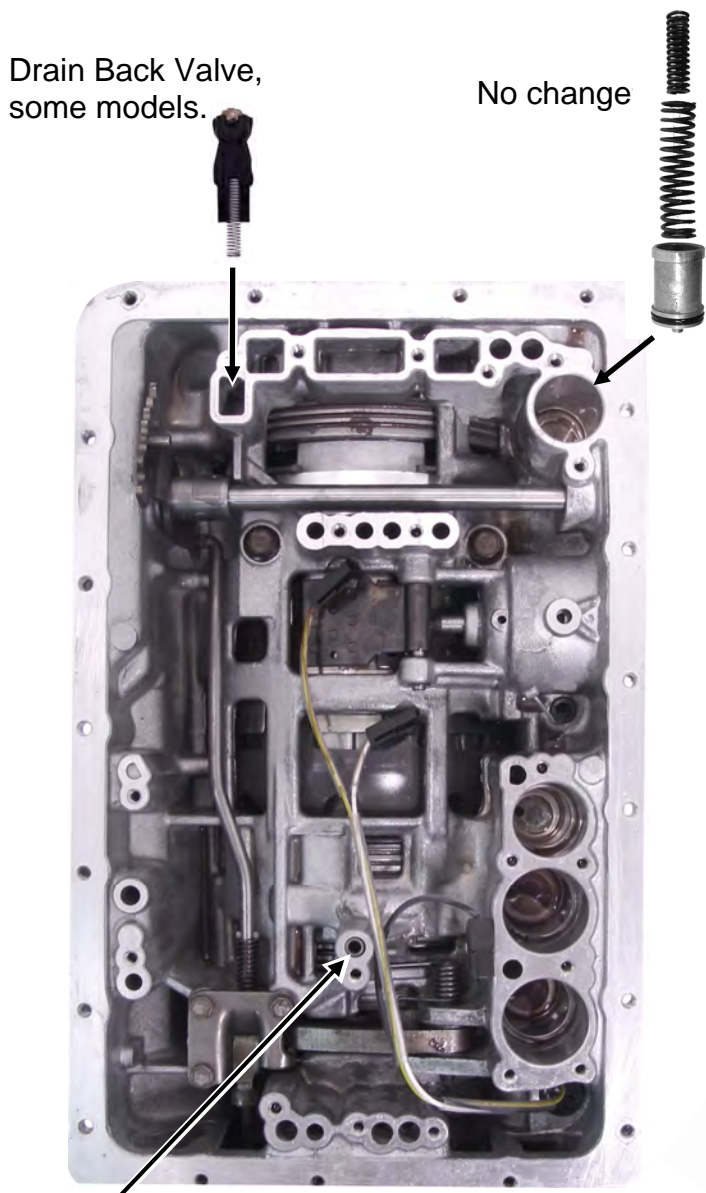


Your Gaskets may vary

Plate to **upper** Valve Body Gasket



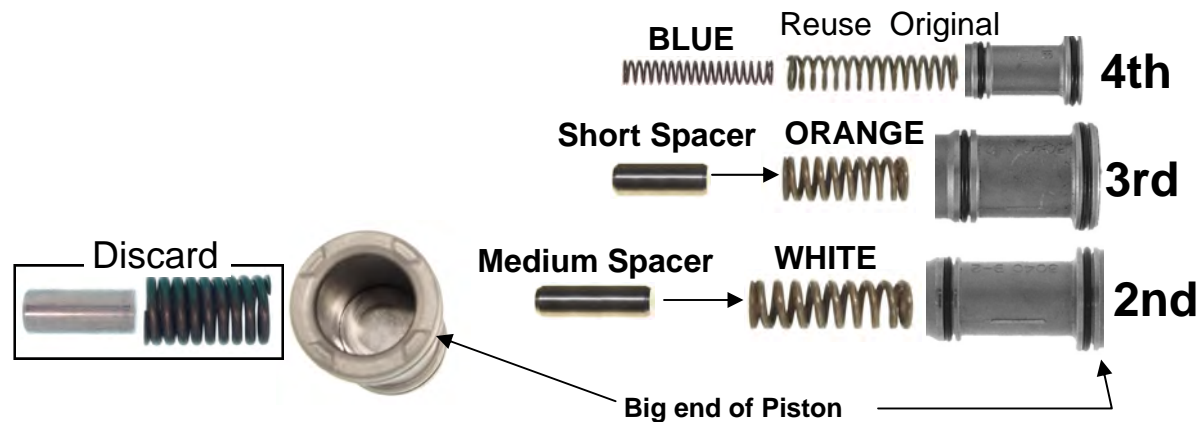
Accumulators, All VB types



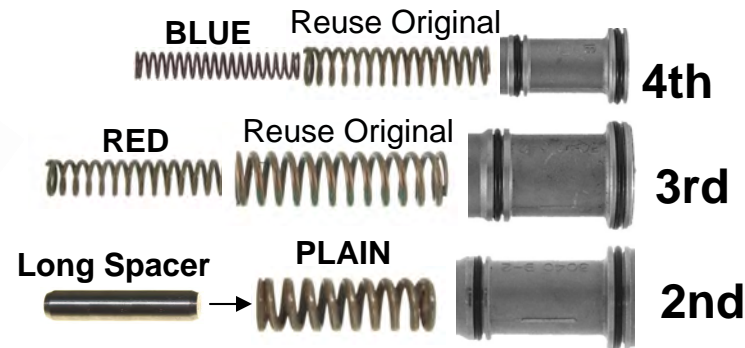
Rubber tip tube (if it fell out) installs rubber end into hole first.

01 May 2013

Type A Accumulators have either a deep pocket on the big end of the Piston or they are flat. Discard ALL Springs and Spacers on big end of Pistons if equipped. Install new Springs and Spacers on the small end and reuse original 4th Spring.



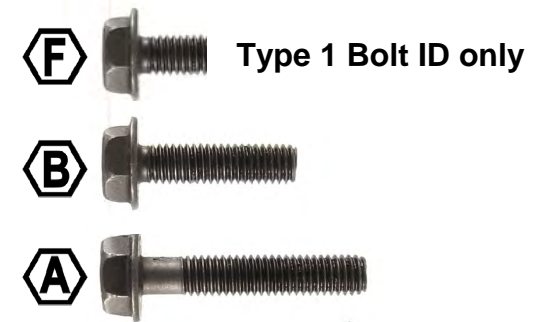
Type B Accumulators have a short Spring **attached** to the big end of the Piston. With diagonal Cutters remove short Springs on ALL Pistons. Install new Springs & Spacer on small end and reuse original 3rd & 4th Spring.



Valve Body Installation

Step 1

Install Accumulator Pistons & (if equipped) Drain Back Valve into Case. Line up Manual Valve to Linkage Pin during Valve Body installation. If Trans is in the car get a buddy to assist you installing the Valve Body. Install & tighten Z Bolts first, Valve Body Bolt torque is 80-89 inch pounds.



Step 2

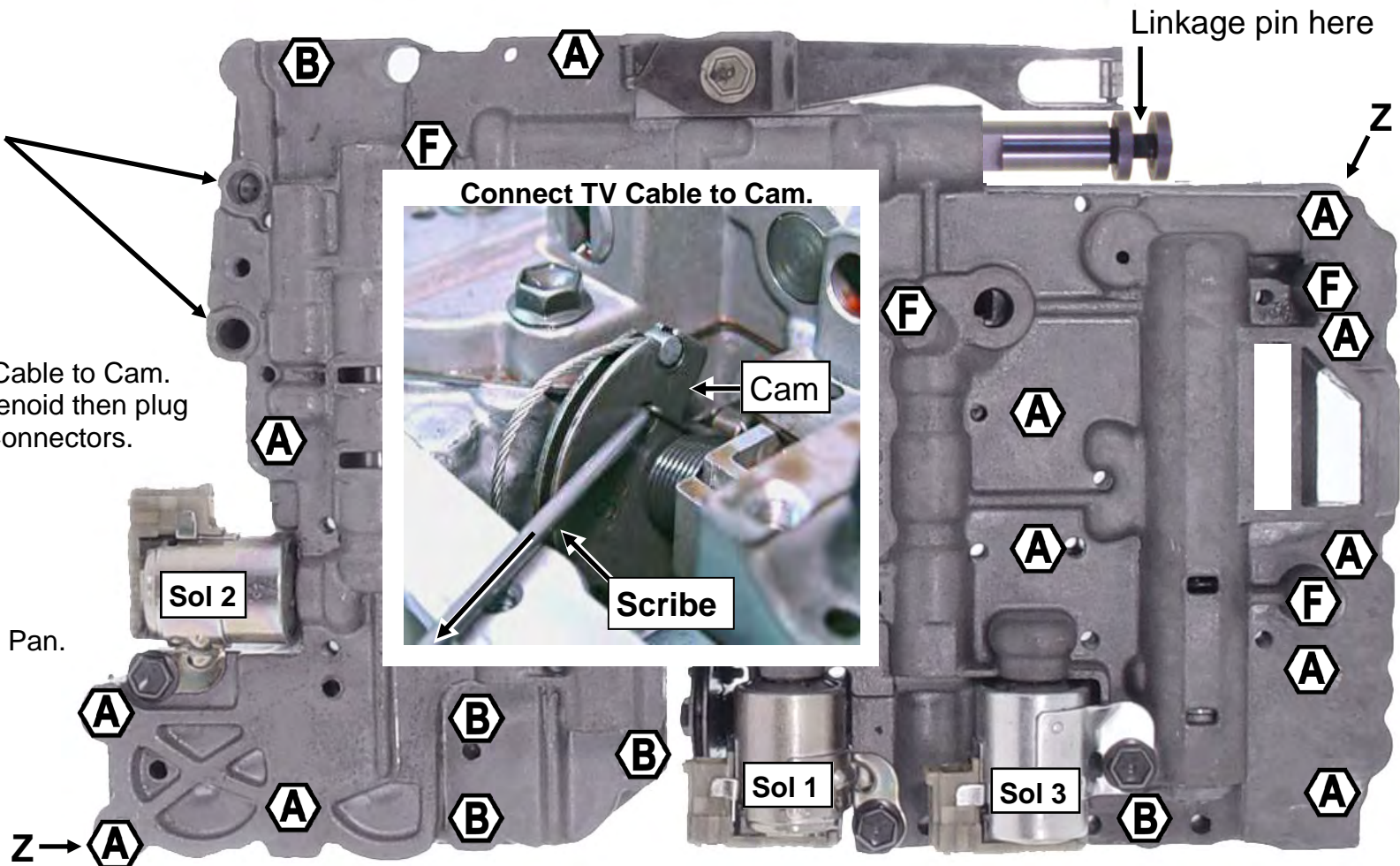
Install Tubes (if equipped)

Step 3

Connect TV Cable to Cam. Install #1 Solenoid then plug in Solenoid Connectors.

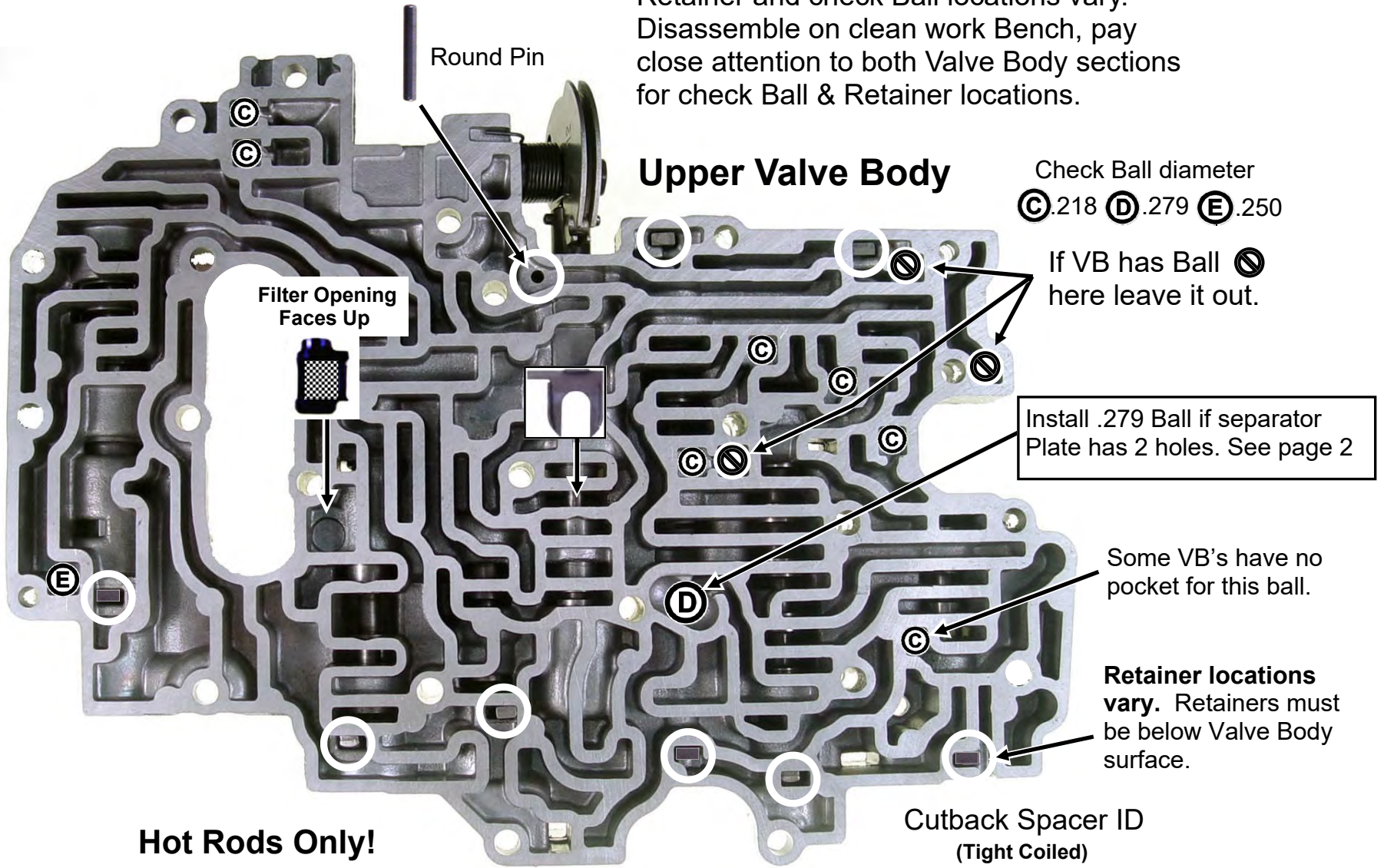
Step 4

Install Filter & Pan.

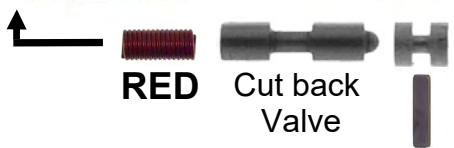


Type 1 VB: Instructions

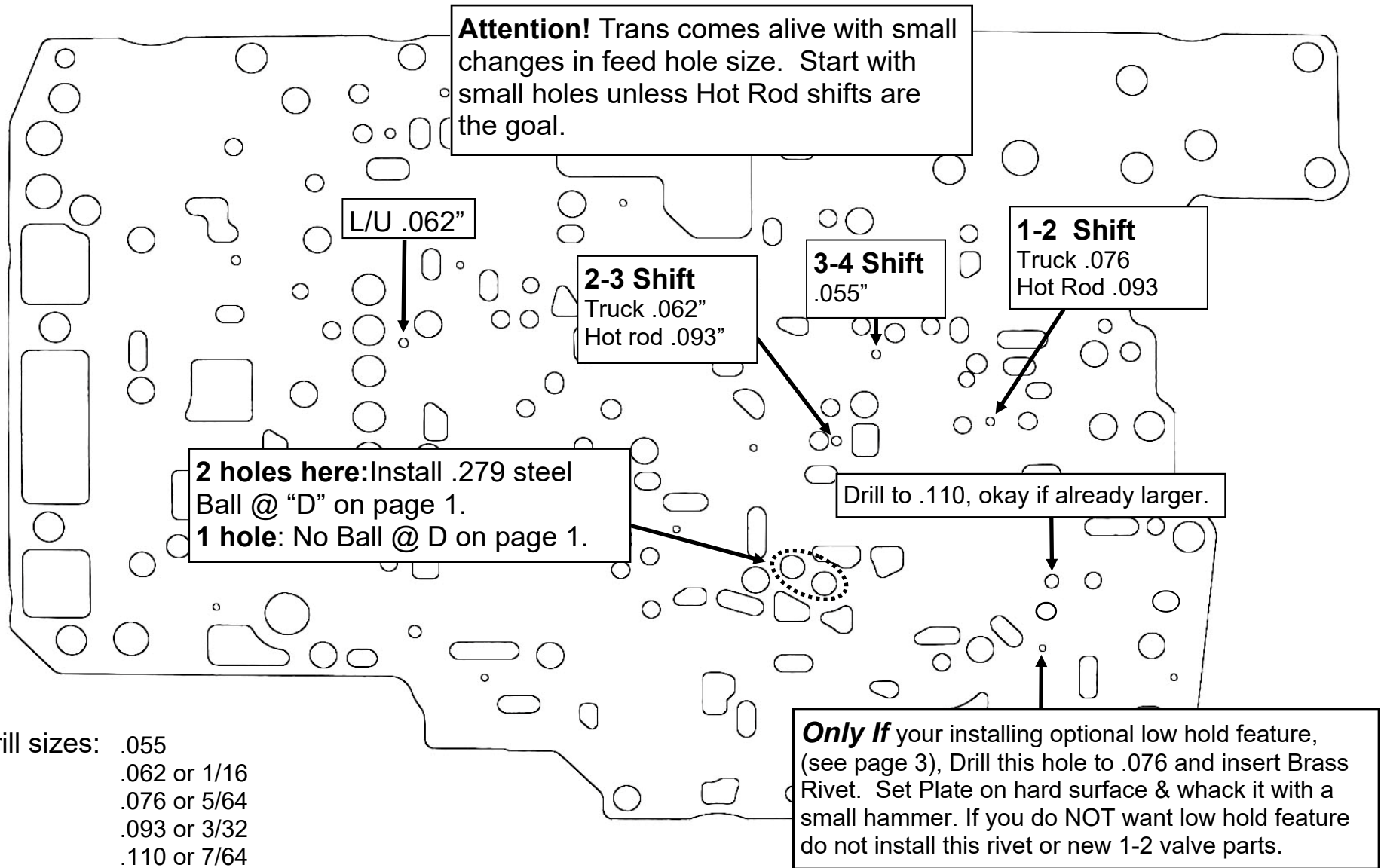
Attention:
 Retainer and check Ball locations vary.
 Disassemble on clean work Bench, pay
 close attention to both Valve Body sections
 for check Ball & Retainer locations.



Hot Rods Only!
Step 1 Discard OE spring
 and install new **RED** Spring.



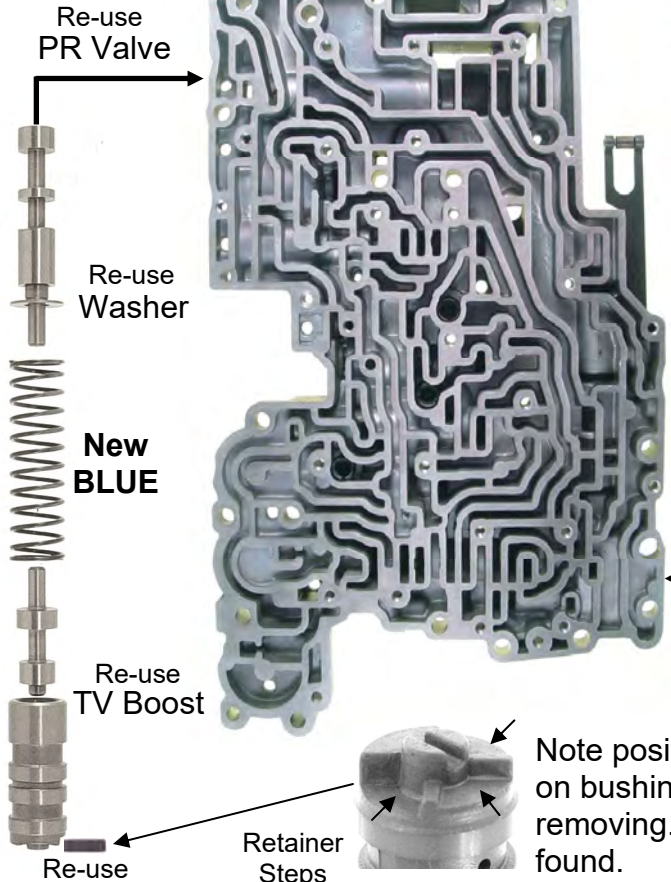
Type 1 Separator Plate



Drill sizes: .055
.062 or 1/16
.076 or 5/64
.093 or 3/32
.110 or 7/64

Type 1 Lower Valve Body

Step 1 Install new BLUE PR Spring.

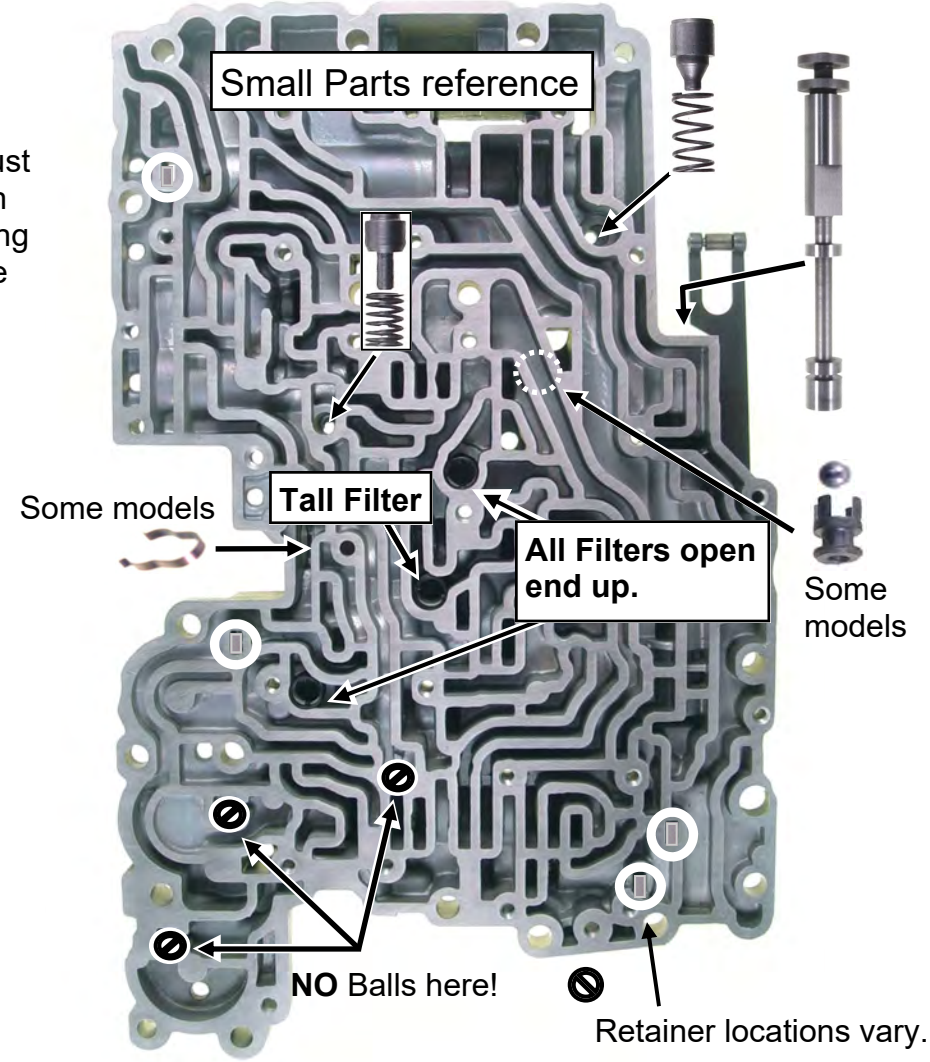


Step 2: Optional Low Hold Feature.

Keeps Trans from up shifting in Man 1st.
 Remove & discard original 1-2 shift Valve. Insert .250" steel Ball into **New 1-2 shift Valve**. Place assembly lube on the end of the Pin and insert into new 1-2 Valve and install into Valve Body.

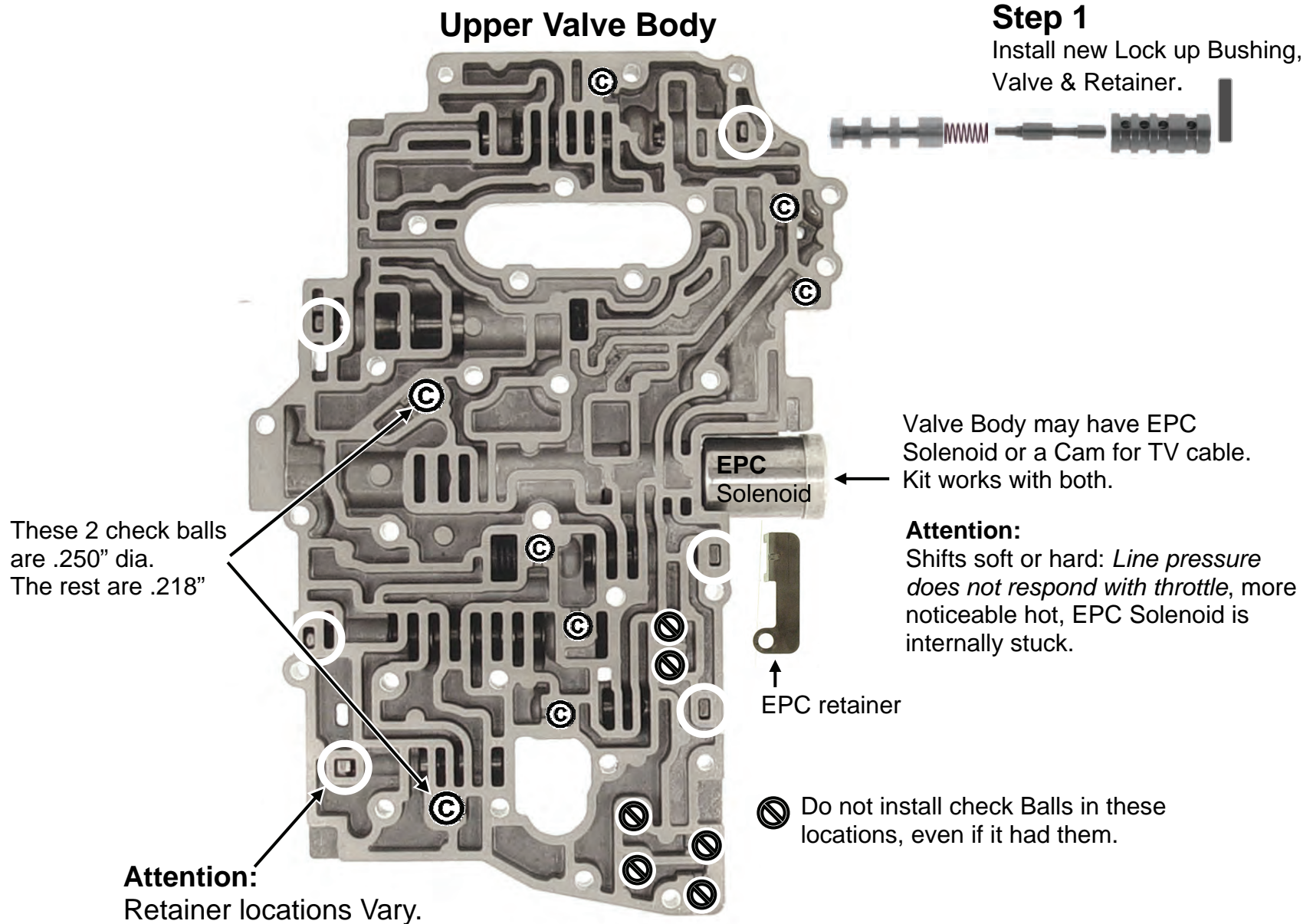


Brass Rivet must be installed in plate when using new 1-2 valve see page 2.



Note position of retainer on bushing step before removing. Re-install as found.

Type 2 VB: Instructions



Type 2 Separator Plate

Attention! Trans comes alive with small changes in feed hole size. Start with small holes unless Hot Rod shifts are the goal.

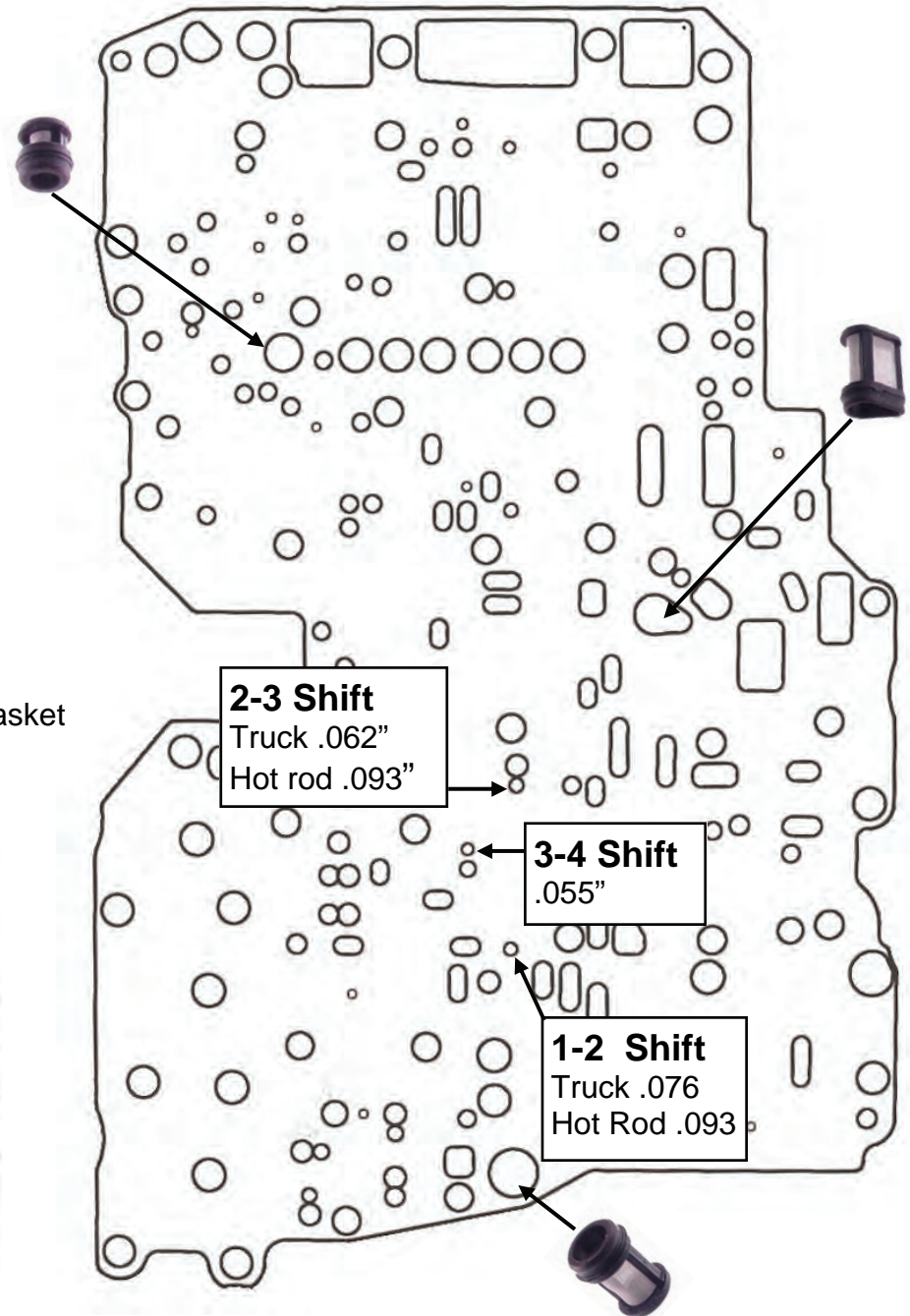
- Drill sizes:
- .055
 - .062 or 1/16
 - .076 or 5/64
 - .093 or 3/32
 - .110 or 7/64

Gaskets must not cover any holes in separator Plate

Plate to **upper** Valve Body Gasket

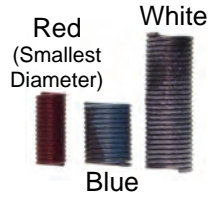


Plate to **lower** Valve Body Gasket



Type 2 Lower Valve Body

Cutback Spring ID
(Tight Coiled)



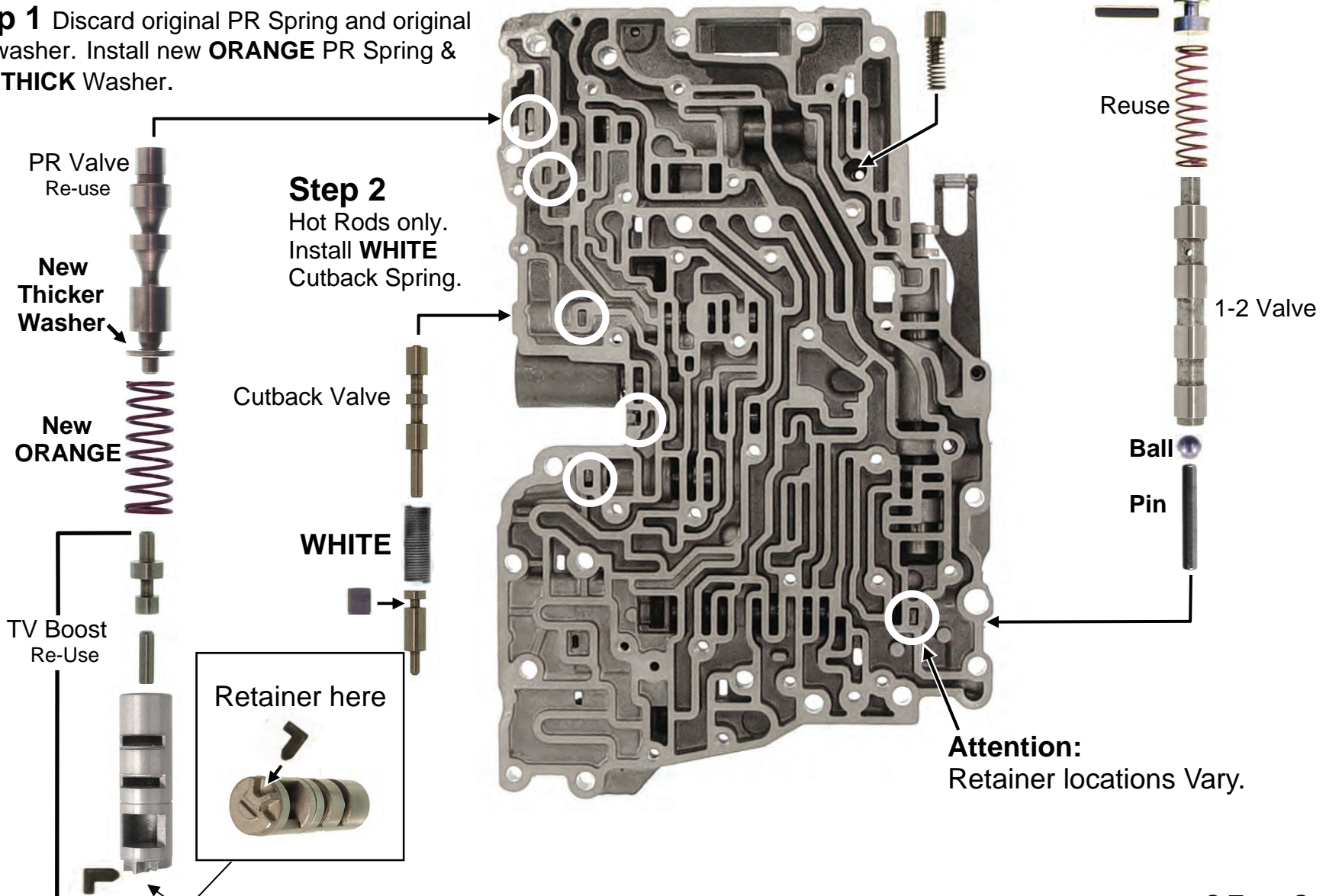
Step 3: Optional Low Hold Feature.

Keeps Trans from up shifting in Man 1st.
Remove & discard original 1-2 shift Valve. Insert .250" steel Ball into **New 1-2 shift Valve**. Place assembly lube on the end of the Pin and insert into new 1-2 Valve and install into Valve Body.

Step 1 Discard original PR Spring and original thin washer. Install new **ORANGE** PR Spring & New **THICK** Washer.

Step 2

Hot Rods only.
Install **WHITE** Cutback Spring.



Type 3 VB: Instructions

Upper Valve Body

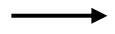
Step 1

Install new Lock up Bushing, Valve & Retainer.



Attention:

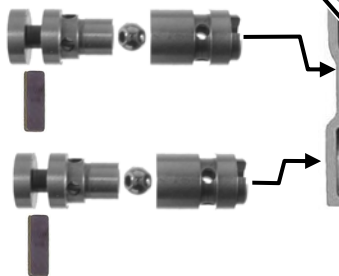
Retainer locations Vary.



These 2 check balls are .250" dia.
The rest are .218"

Watch it!

These Check Valves like to fall out.



Valve Body may have EPC Solenoid or a Cam for TV cable.
Kit works with both.

Do not install check Balls in these locations, even if it had them.

Type 3 Separator Plate

Attention! Trans comes alive with small changes in feed hole size. Start with small holes unless Hot Rod shifts are the goal.

- Drill sizes:
- .055
 - .062 or 1/16
 - .076 or 5/64
 - .093 or 3/32
 - .110 or 7/64

Gaskets must not cover any holes in separator Plate

Plate to upper Valve Body Gasket

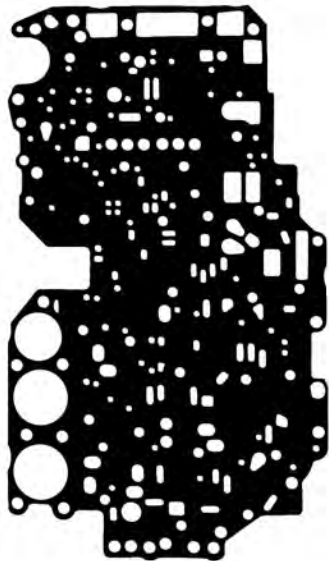
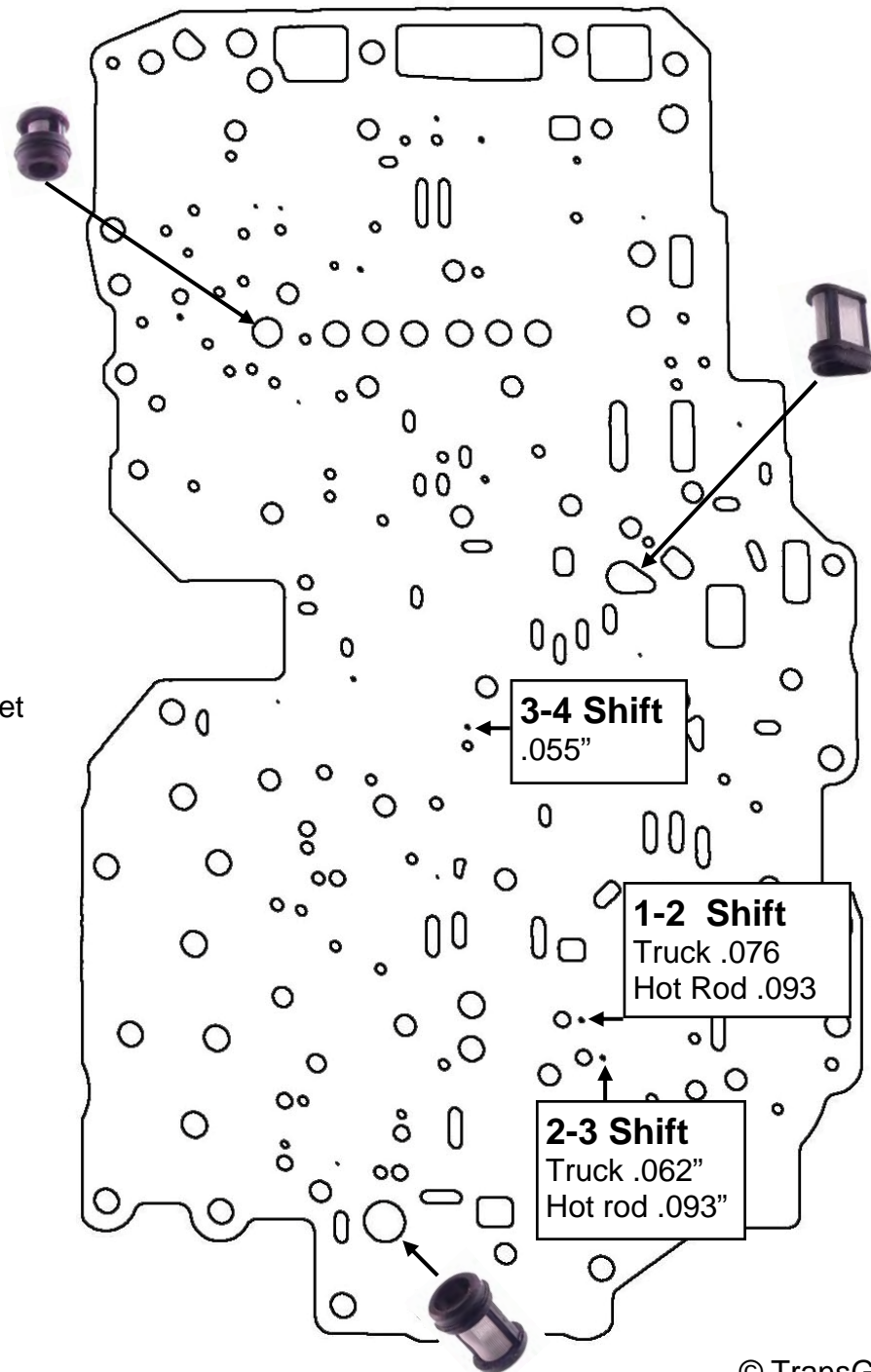
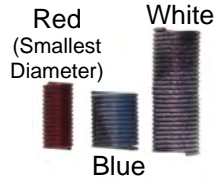


Plate to lower Valve Body Gasket



Type 3 Lower Valve Body

Cutback Spring ID
(Tight Coiled)

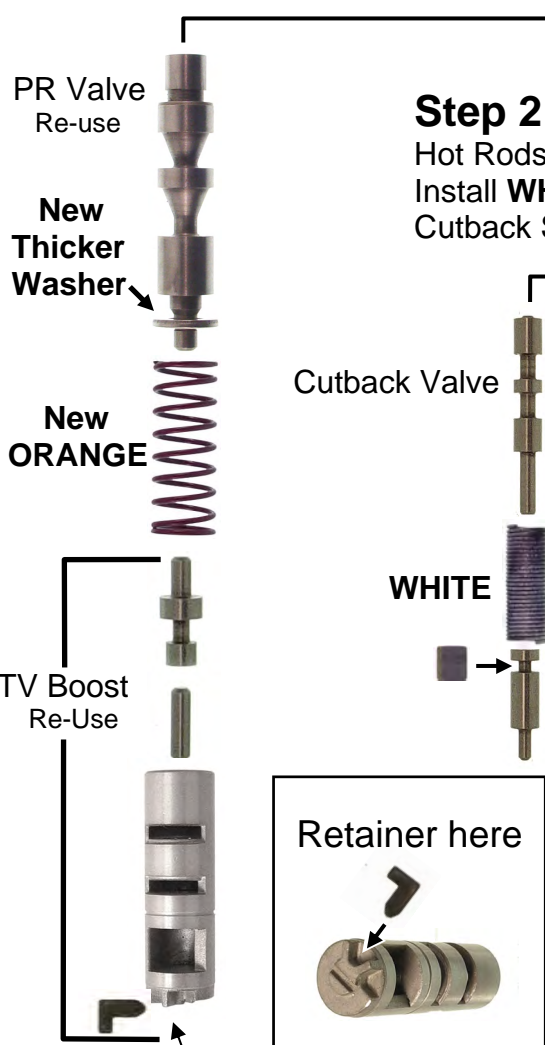


Step 3 :Optional Low Hold Feature.

Keeps Trans from up shifting in Man 1st.

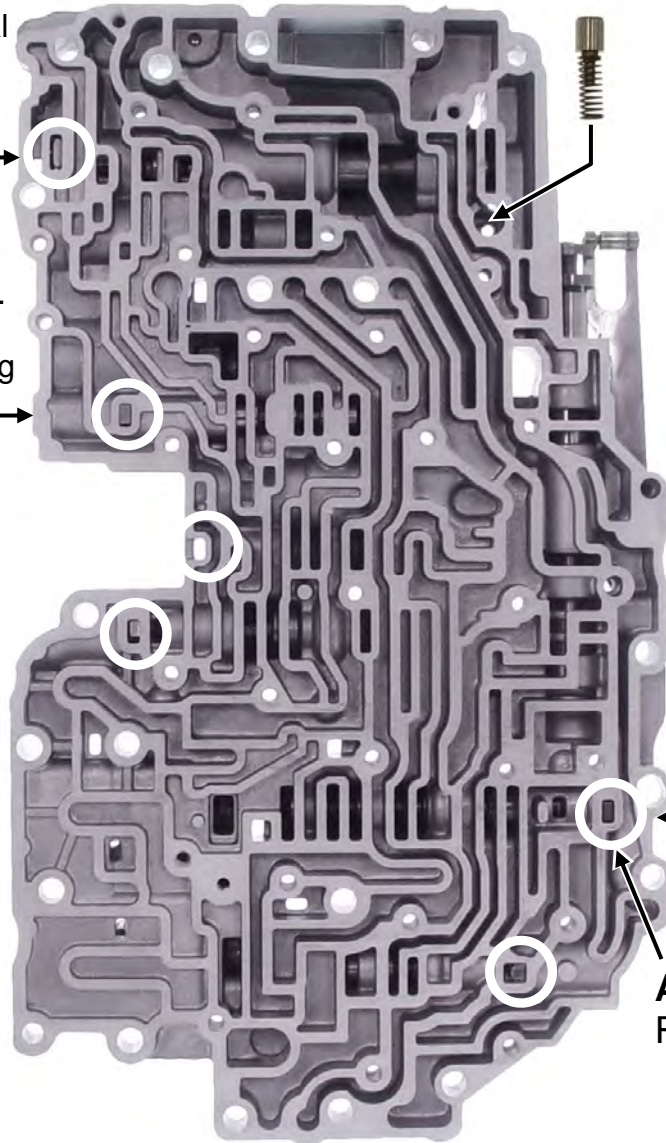
Remove & discard original 1-2 shift Valve. Insert .250" steel Ball into **New 1-2 shift Valve**. Place assembly lube on the end of the Pin and insert into new 1-2 Valve and install into Valve Body.

Step 1 Discard original PR Spring and original thin washer. Install new **ORANGE** PR Spring & New **THICK** Washer.



Step 2

Hot Rods only.
Install **WHITE**
Cutback Spring



Attention:
Retainer locations Vary.

Type 4 VB: Instructions

Upper Valve Body

Step 1

Install new Lock up Bushing, Valve & Retainer.

Attention:
Retainer locations Vary.

These 2 check balls
are .250" dia.
The rest are .218"

Valve Body may have EPC
Solenoid or a Cam for TV cable.
Kit works with both.

Watch it!
These Check
Valves like to
fall out.

Do not install check Balls in these
locations, even if it had them.

Type 4 Separator Plate

Attention! Trans comes alive with small changes in feed hole size. Start with small holes unless Hot Rod shifts are the goal.

Drill sizes: .055
.062 or 1/16
.076 or 5/64
.093 or 3/32
.110 or 7/64

Gaskets must not cover any holes in separator Plate

Plate to upper Valve Body Gasket

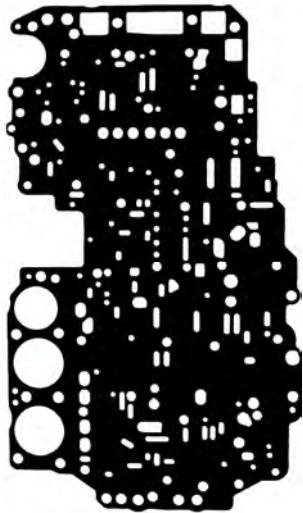
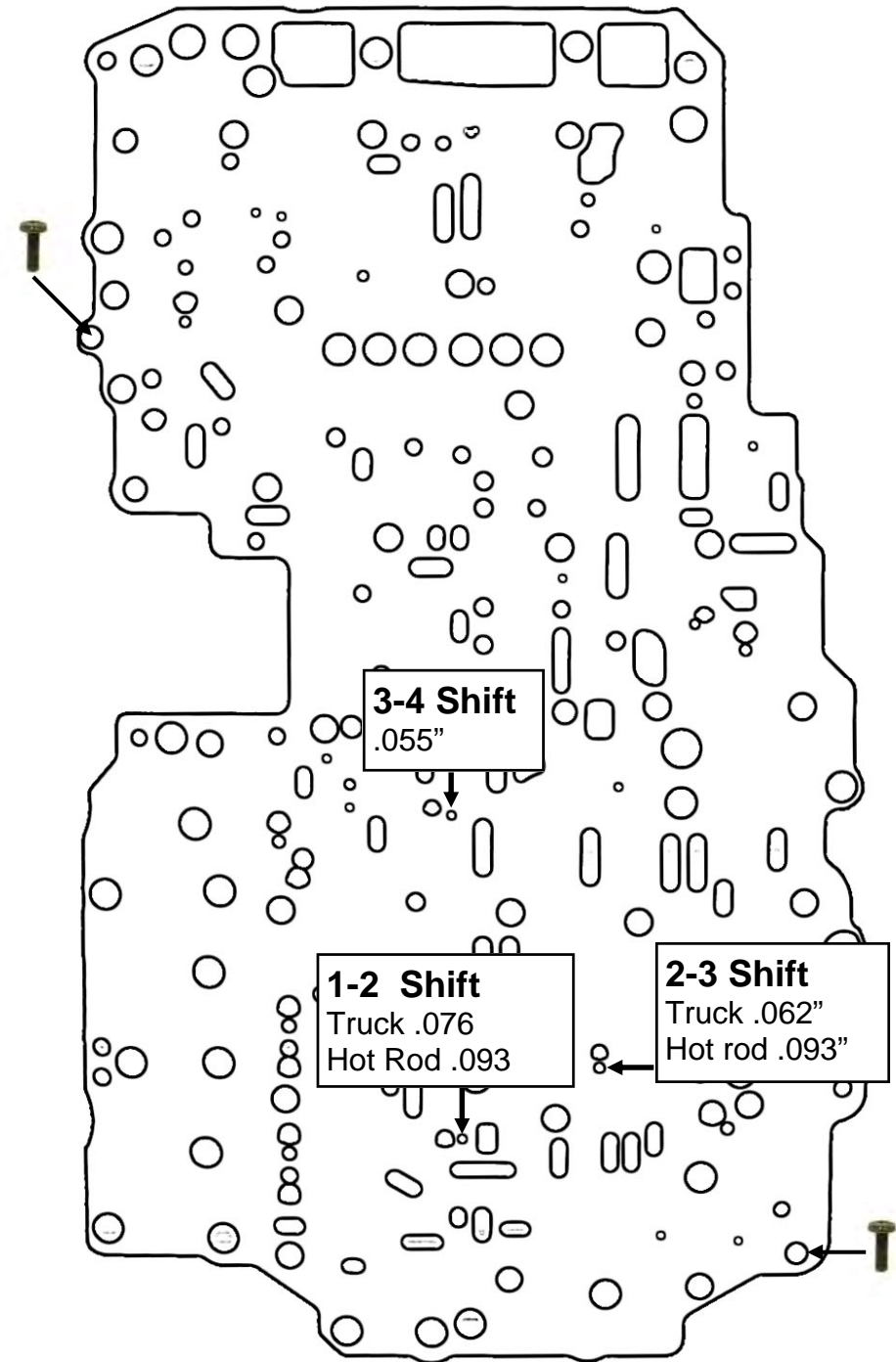


Plate to lower Valve Body Gasket



Type 4 Lower Valve Body

Cutback Spring ID
(Tight Coiled)

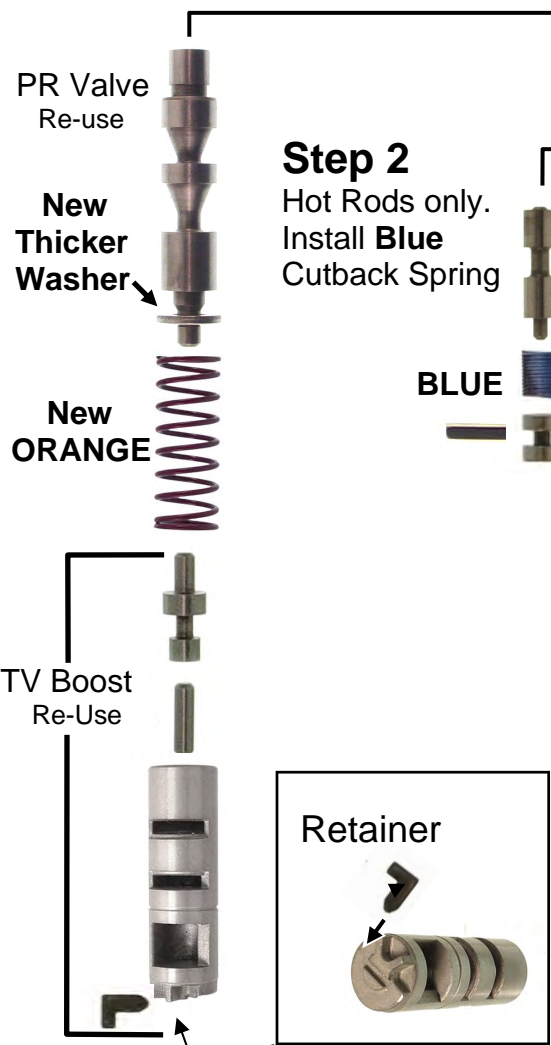


Step 3: Optional Low Hold Feature.

Keeps Trans from up shifting in Man 1st.

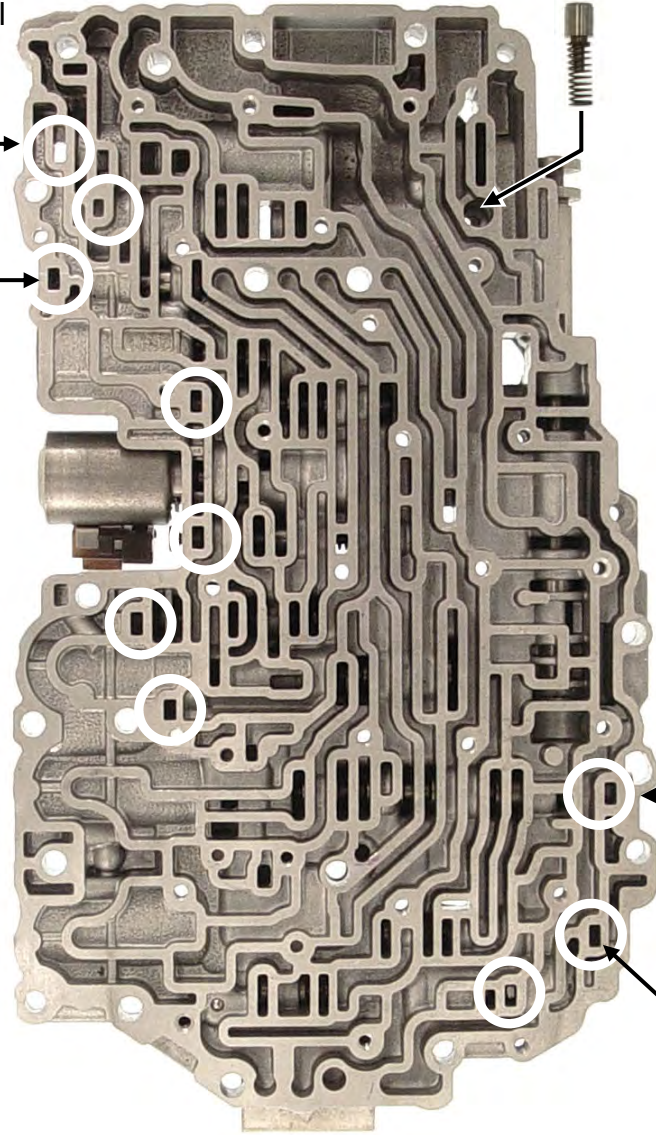
Remove & discard original 1-2 shift Valve. Insert .250" steel Ball into **New 1-2 shift Valve**. Place assembly lube on the end of the Pin and insert into new 1-2 Valve and install into Valve Body.

Step 1 Discard original PR Spring and original thin washer. Install new **ORANGE** PR Spring & New **THICK** Washer.



Step 2
Hot Rods only.
Install **Blue**
Cutback Spring

BLUE



Attention:
Retainer locations Vary.