

62TE-HP

High Pressure Tuneless™ Reprogramming™ Kit

An essential performance and durability upgrade for hard-working ProMaster and passenger vans to prevent 2-4 clutch failures, especially in shift busy delivery vehicles. A recalibrated pressure curve delivers increased clutch and TCC holding capacity with short, clean shifts at all throttle openings. A 26% overall increase in line pressure takes this unit from (stock OEM) 60-135 psi to (TransGo) 75-170 psi.

Corrects, Prevents, Reduces:

- 2-4 clutch failure
- Overheating
- TCC Slip/shudder
- Drain back
- Delay or no forward or reverse
- Coasting 6-5 underdrive apply clunk or 3-2-L/R apply clunk



Tip: After every repair, clear codes and reset the VLP Line Pressure Counter found under the 'Special Functions' tab.

Step 1. Discard original L/R housing gasket. Install **new non-shrinking gasket** under piston housing. This gasket works great with all L/R piston housings.

Step 2. After you've installed your clutches and piston housing, fit the new, wider 2-4 clutch piston retainer snap ring into the top groove.

This snap ring was re-engineered to significantly reduce deflection upon 2-4 clutch apply.

New, wider 2-4
clutch piston
retainer snap ring



Install new non-shrinking gasket



If housing is bent or has damaged holes from over tightening of retaining screws, replace it.



Accumulators

Do not make any changes to the accumulator springs, except the 2/4 as shown in Step 3.

Step 3. Install the **3 new sealing rings** on the new 2/4 orange billet accumulator piston. Insert the **new plain 2/4 spring** into the piston. Do **NOT** use expander wires on the this piston.



Piston scuffing? Excessive wear?
Upgrade plastic pistons to prevent transmission failure due to piston breakage.

RFE-ACMPST-KIT 5 billet aluminum pistons and sealing rings

Step 4. OEM plastic pistons

Skip this step, reusing original sealing rings.

OEM aluminum pistons

Install **new expanders and sealing rings** on the closed end of the UD, LR, OD, DC and LC aluminum accumulator pistons.

Install **new expander wire** and **new sealing ring** into the upper groove only.
Install the **expander wire first**, then the sealing ring.

For use with aluminum pistons only.

Reuse original springs.
Assembly installs **spring-first** into the case.

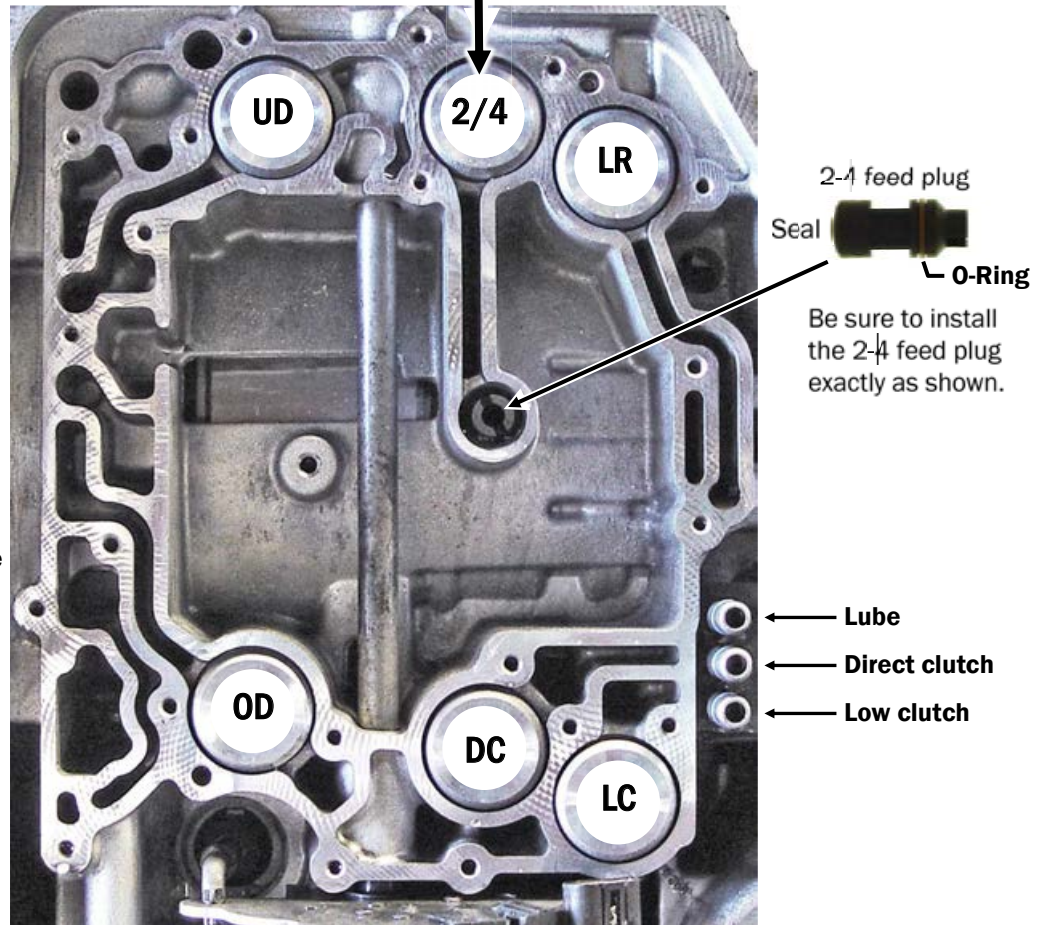
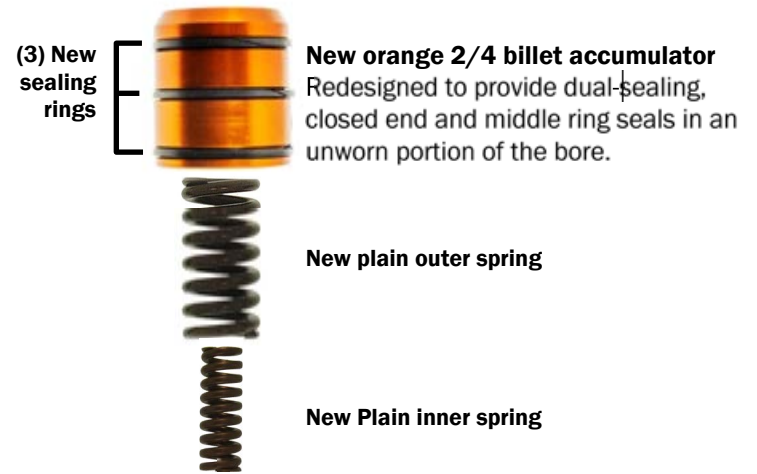
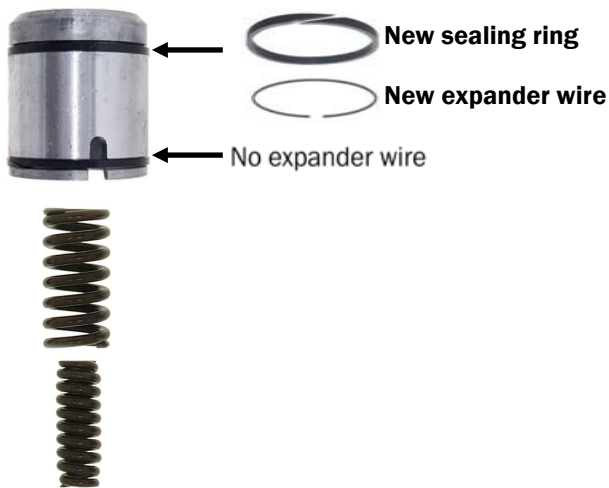

Valve Body Repairs

Step 5. Index tool: Using the existing guide pin and a valve body bolt, drill through the casting with the 0.156" drill bit provided.

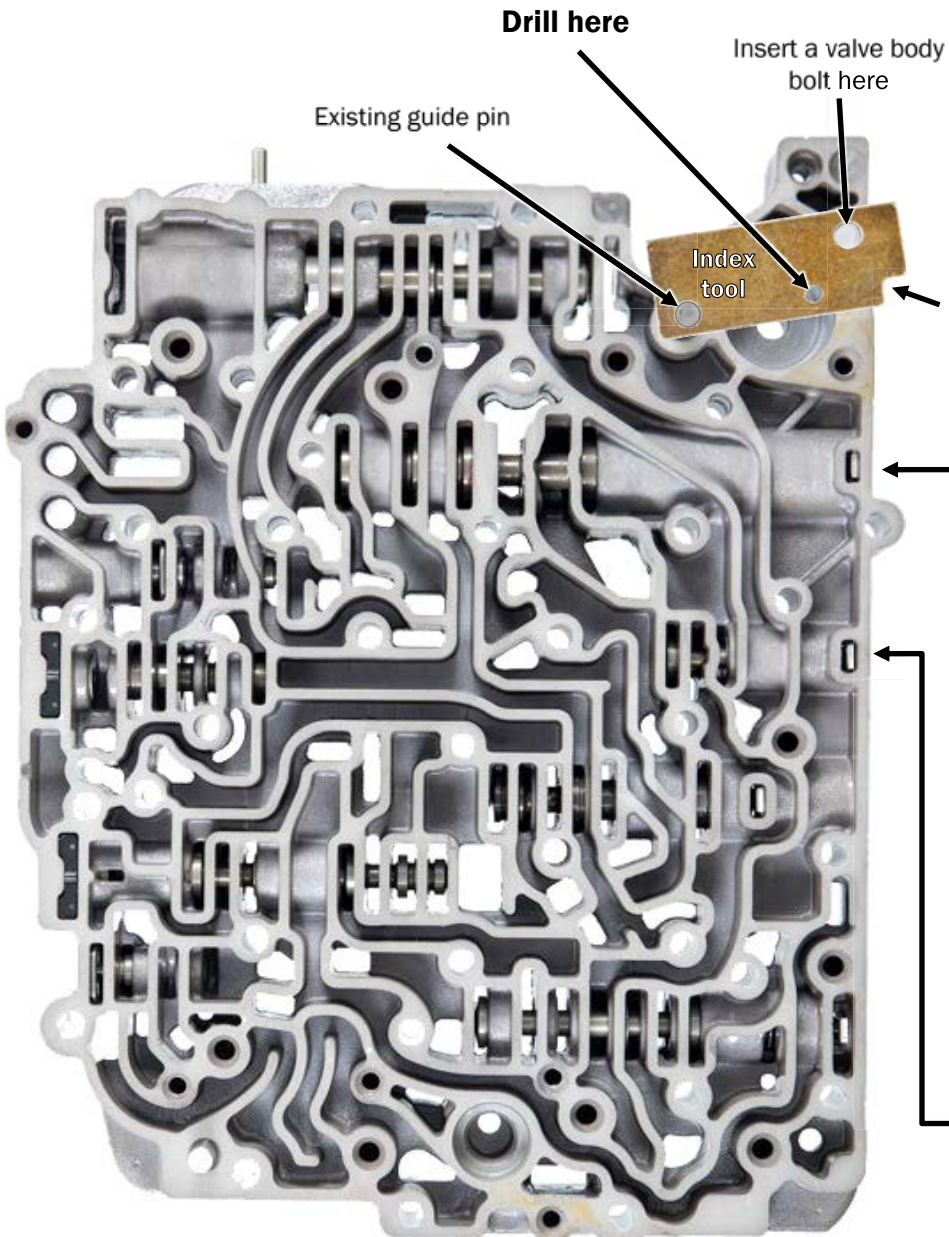

Step 6. Using a flat punch, insert the furnished cup plug from the transducer side into the drilled hole until **flush** with the top of the casting.

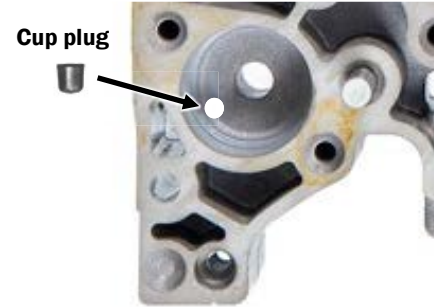

Alignment notch must face down and to the right (away from the guide pin).

Step 7. Install **new PR valve**, ensuring it travels freely, then the **new blue PR spring**, and reuse the retainer.

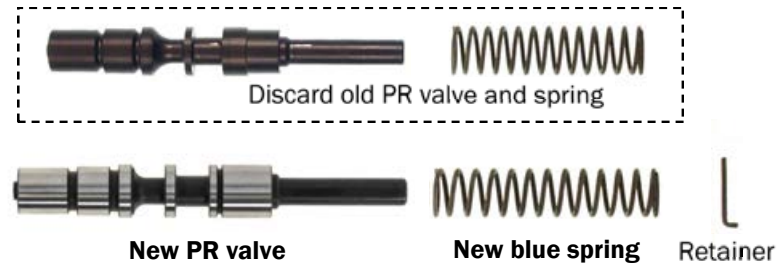

Step 8. Install **new TC limit bushing, gold ball, orange spring**, and reuse the retainer. **Regardless of the amount of bore wear this system works perfectly!**



Listen up!

The low drum and case are prone to wear causing the snap ring to blow out the top of the drum. **(Figure 1 and 2)**

Always inspect the drum **(Figure 3)** and the case **(Figure 4)** closely for wear. The low drum should have an interference fit in the case. Removing the drum should be difficult and require the use of a slide hammer.

If the drum comes out easily without the need to use a slide hammer, the drum is bad, and must be replaced. Inspect the case for excessive wear as well.

Tip: With a good drum and case, the tapered snap ring that holds the drum in the case will stop before bottoming out in the bottom of its groove.



Figure 1



Figure 2

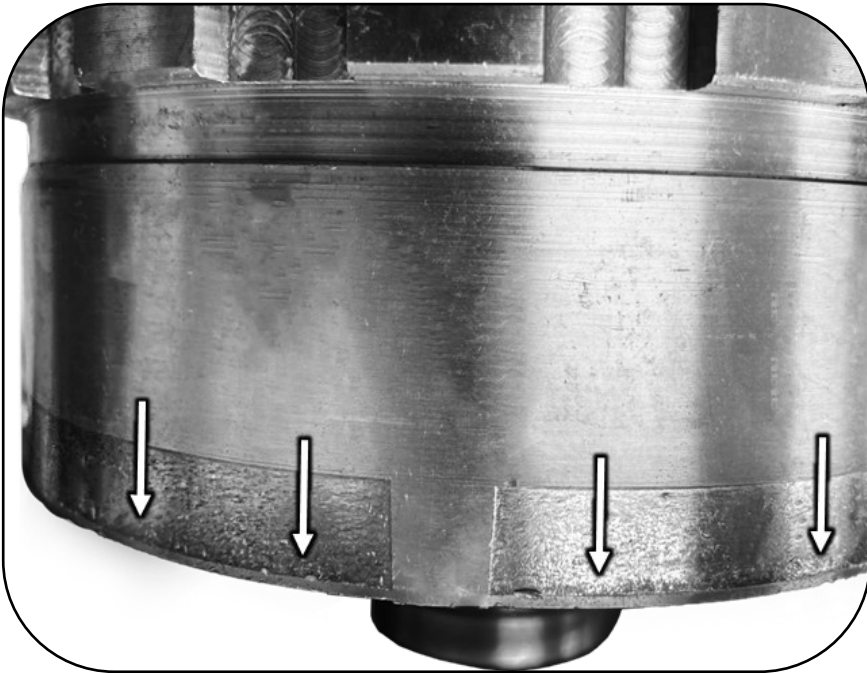

Figure 3

Look closely for low drum wear (as shown in the example above) where the arrows point on the side of the drum as well as where the drum sits against the lip in the case.

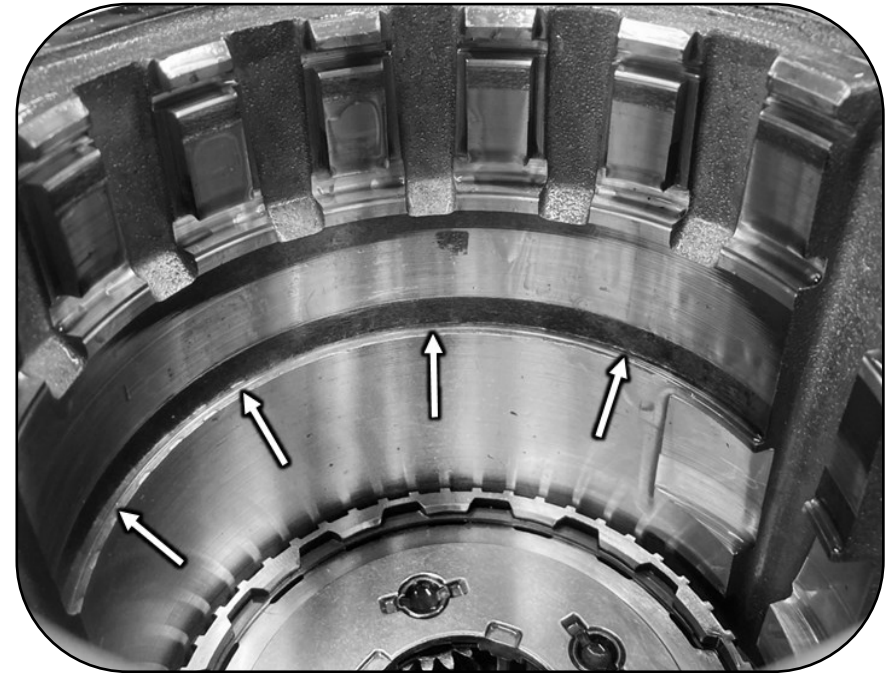

Figure 4

Look closely for case wear (as shown in the example above) where the arrows point at the lip where the low drum stops in the case as well as the area above it.

62TE Additional Data

Compounder one-way clutch

The stepped side of the outer race faces into the low drum. When sprag assembly is installed in the low drum, the outer race must rotate counterclockwise while the drum held stationary.

Flat side of outer race faces up when installed in low drum

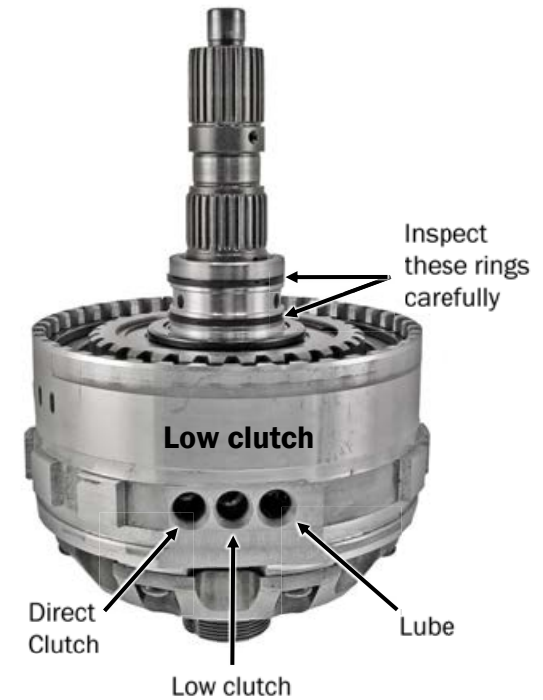
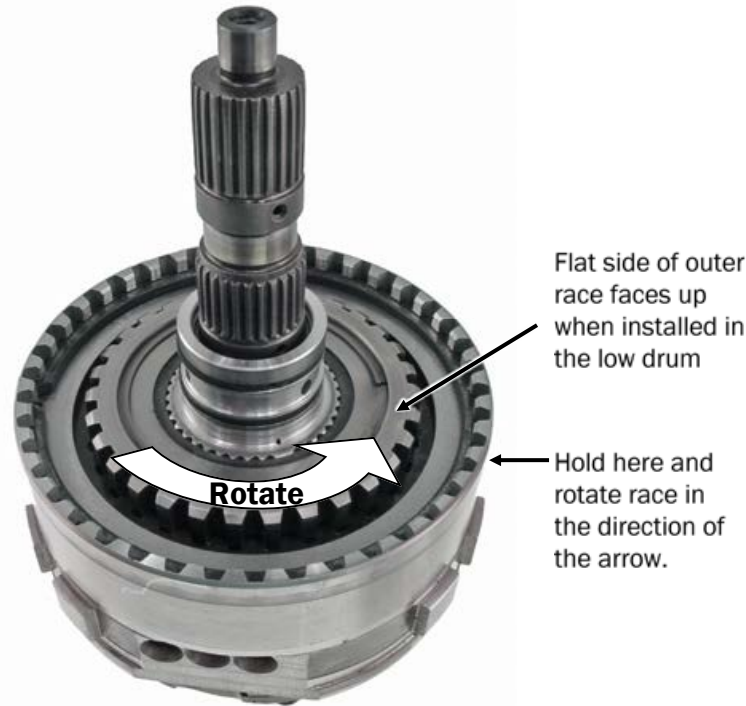
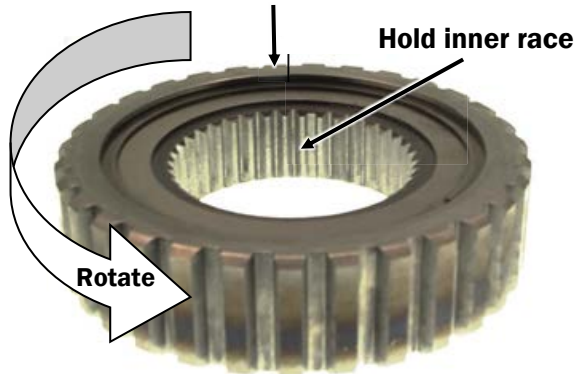

Note: This bearing was omitted on later models

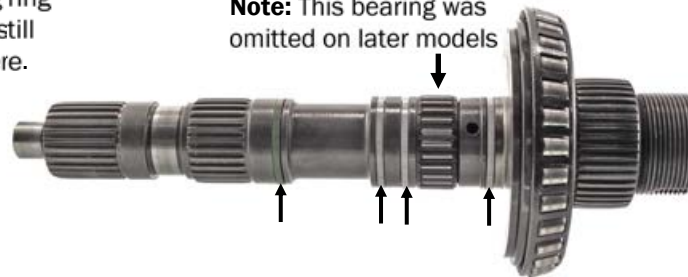

Transfer Shaft

These 4 rings like to shrink dumping lube oil that can lower main line and accelerate ring land wear on the low clutch housing. OE part # 68018615AA

Low Clutch Housing

Early rotating rings usually destroy the ring grooves on low clutch housing. Later housings are notched for non-rotating rings (OE part # 05078800AB) OE rings aircheck great and work excellent in these notched housings. **20-25 psi of regulated air must apply the direct clutches on the bench, don't assemble unit until they do!**

Updating the low clutch housing to the latest non-rotating ring type housing during overhaul is an great way to prevent rework due to ring groove damage. Even though it may not be damaged at time of overhaul, be warned, it does have a known high failure rate. Remember the customer pays for the parts now, you pay for them later.

Direct Clutch

Loss of lube from shrunk sealing rings on the transfer shaft will accelerate wear on the ring tower causing direct drum rings to leak.

62TE General Data

The 62TE is a 6 speed transaxle. It has a 7th speed that is only used during a 6-4 kickdown, this 7th speed is known as 4th prime.

62TE Clutch Application

Gear	Ratio	UD	OD	REV	2-4	L-R	LC	DC	ORC
1	4.127	On				On	On		Hold
2	2.842	On				On		On	
3*	2.284	On			On		On		Hold
4^	1.573	On			On			On	
4	1.452	On	On				On		Hold
5	1.000	On	On					On	
6	.0689		On		On			On	
Reverse	3.215			On		On	On		

3* Is failsafe/limp mode

4^ Is 4th prime, used only on kickdown

Clutches on the transfer shaft are:

- Low
- Direct
- One way (ORC)

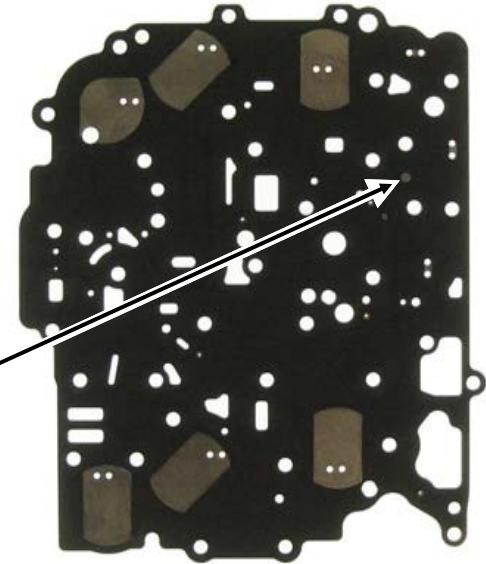

Install ball here only if plate has this hole.

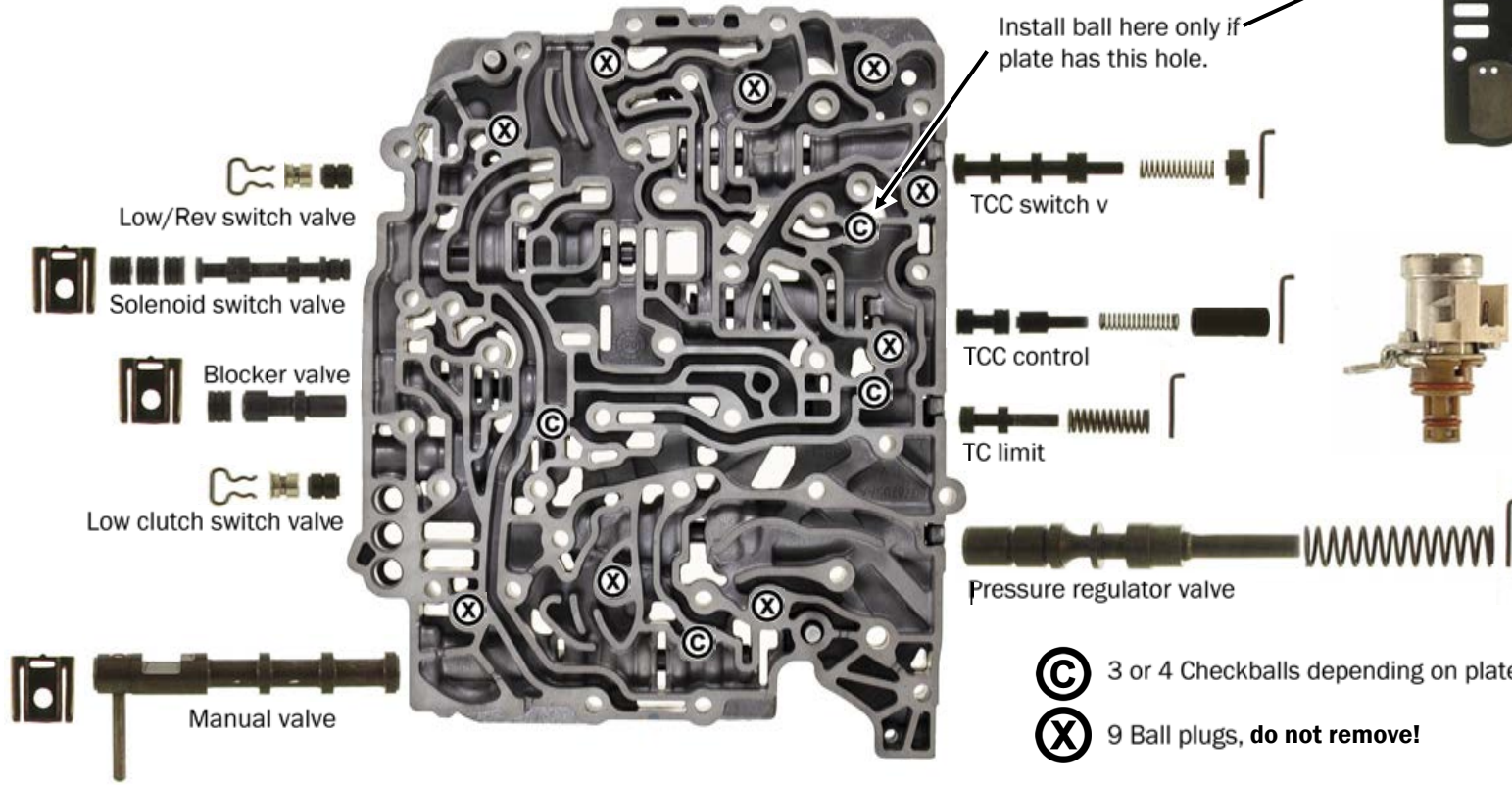

TCC solenoid often fails causing “chugs” or “kills” engine at a stop. Replace it.

- Ⓒ 3 or 4 Checkballs depending on plate type.
- ⓧ 9 Ball plugs, **do not remove!**

A quick and easy one-step solution to eliminate trouble codes and frequent complaints on 62TE.

Solenoid Switch Valve Kits

Fits 604/606, 40-41TE, 42LE, 62TE, 42RLE, 45/545/65/66/68RFE

- #RFE-SV420-WT .420 diameter with tools
- #RFE-SV420-NT .420 diameter no tools
- #RFE-SV453-WT .453 diameter with tools
- #RFE-SV453-NT .453 diameter no tools

Corrects/Prevents/Reduces:

- Codes P0871, P1776, P1775
- L/R pressure switch rational or circuit error
- OD clutch failure

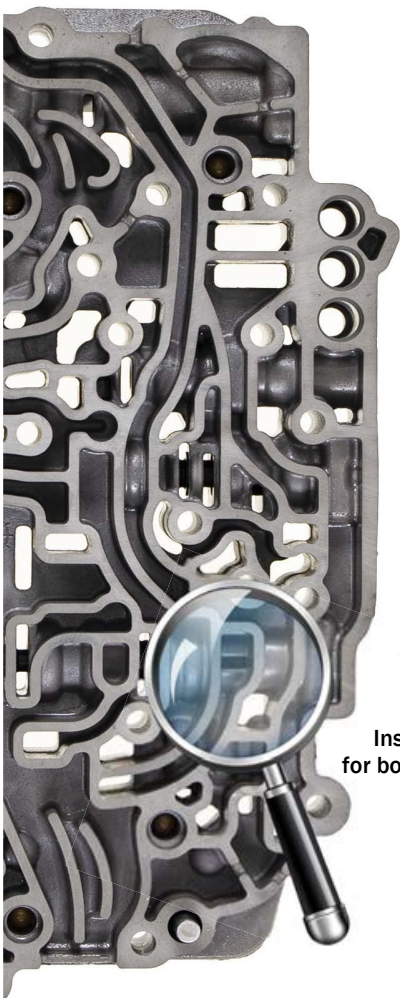

Inspect for bore wear



Solenoid Switch Valve Measure here

SAVE TIME

- Made-in-USA dual-piloting reamers are drill-motor-friendly
- Tip: Use 20V cordless 3SPD drill with 1/2" chuck set on low speed
- Large technical images and diagrams
- Installs in under 5 minutes

SAVE MONEY

- No need to buy valve bodies
- No need for expensive tooling
- No holding fixture required
- Save and reuse reaming tools for refill kits



RFE-SV453-WT shown

Easy-to-install drop-in billet dual-sealing accumulator pistons. No time consuming special installation process or tooling required.

#RFE-ACMPST-KIT

Billet Accumulator Piston Kit

Fits 604/606, 40-41TE, 42LE, 62TE, 42RLE, 45/545/65/66/68RFE

Features:

- Two sealing rings double the sealing capacity over OE
- Our new additional center ring seals in a previously unused area of the bore allowing reuse of the valve body or case even when damaged by side-loading of the OE design accumulator piston

- The third ring, combined with a shallower groove in the piston, acts as a guide preventing damage from side loading the OE piston
 - Billet aluminum to avoid cracking
- Includes:**
- Five billet accumulator pistons
 - 15 scarf-cut PTFE rings



Other **HIGH PRESSURE TUNELESS™** kits from **TRANSGO performance**



RFE: 1999-2018

High Pressure Tuneless™ Reprogramming Valve Body Kit™

#RFE-7B-HP Fits 1999-2010 545RFE, 65RFE, 66RFE, 68RFE 7 ball
#RFE-5B-HP Fits 2011-2018 545RFE, 65RFE, 66RFE, 68RFE 5-ball

High performance without side effects:

- Perfect for hard-working, towing/hauling applications and tuned diesel and Hemi V8
- All programming is done in the hydraulic hard drive (valve body and pump) allowing for the addition of aftermarket engine tunes that increase torque and horsepower
- Will not disrupt the vehicle's computer feedback system, trigger trouble codes or overcharge the torque converter

- Internally balanced calibrations provide progressive, seamless clutch apply pressure increases to 210 psi max, a 30 percent increase over the OEM 160 psi max
- Re-engineered converter clutch charge system provides graduated TCC apply pressure increases with a built-in safety relief system to prevent converter ballooning
- No high RPM clutch failure often associated with aftermarket oversized drums



PATENTED

NEW!
NOW AVAILABLE



RFE: 2019-UP

High Pressure Tuneless™ Reprogramming Valve Body Kit™

#RFE-HP-19UP Fits 2019-on 68RFE

- Essential fixes and major durability upgrades for the top complaints of repeat UD and/or OD clutch failure

Features without removing the transmission:

- Stops repeat underdrive clutch failure after raising line pressure with turning and other internal modifications
- Adds 36% more line pressure at all throttle openings without the need of computer software

Must-have for stock, fleet, hard-working, or enhanced powered 2019-on Ram trucks with a 68RFE

Transmission removal not required | No transmission tuning required

- Reduces OD clutch failure with added power
- Major performance and durability upgrades
- Perfect for performance and hard-working trucks
- Short, clean shifts that really hold the power
- Calibration that relearns quickly

Optional features removing the transmission:

- Stops rough lockup when using triple disc converters
- Prevents converter drain back
- Allows use of pump cover with worn TC limit bore



PATENTED

ENGINEERED FOR PERFORMANCE.
DESIGNED FOR DURABILITY.

Visit www.transgo.com for more information

