

AODE-3

Also Fits: 4R70W

Reprogramming Kit™

Stick Shift (Full Manual Control)

Installing this kit Eliminates all Automatic Shifting.

For transplants into non-computer controlled vehicles.

Short, Firm, Full Throttle Shifts With Class, Performance & Durability

THESE ARE THE TRANSMISSION RATIOS:

There are two models of this trans, standard ratio and wide ratio "W" type.

The "W" type [wide ratio] has a "W" molded on rear of trans housing.

"W" type: "1st" 2:84 "2nd" 1.55 "3rd" 1.00 "4th" .7

Std type: "1st" 2:40 "2nd" 1.40 "3rd" 1.00 "4th" .67

To find top gear ratio, multiply axle ratio x 4th ratio [Example $3.73 \times .67 = 2.50$]

Other ratios: Multiply axle ratio x trans ratio. [Example $3.73 \times 2.84 = 10.59$]



2621 Merced Ave El Monte, CA 91733-1997

Step 1. 2nd Accumulator

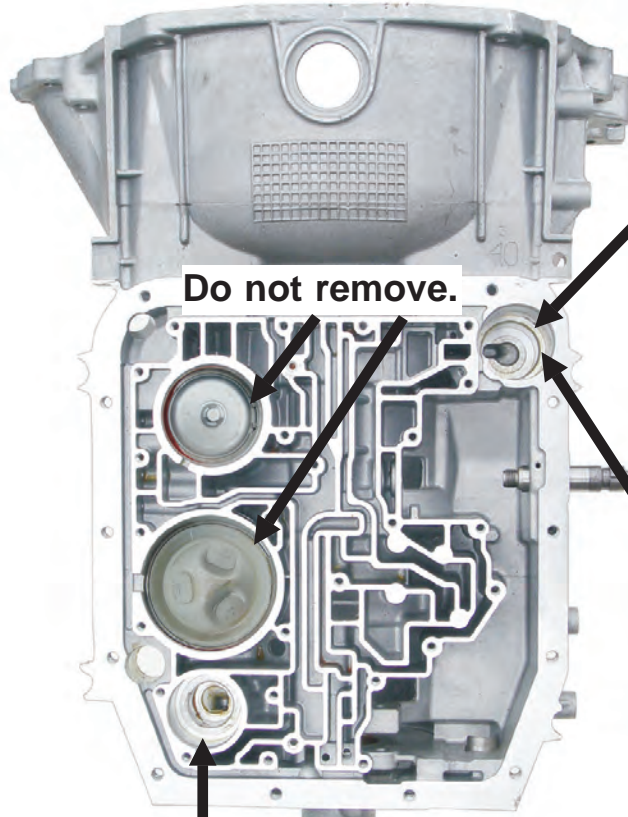

Steel Type Piston

Steel

Washer

BLUE

Solid Spring

After road test: For a firmer 2nd you can install **Spacer** under spring.

Aluminum Type Piston: It's best to upgrade to steel type. Ford #F7AZ-7F251-AA.

After road test: For a firmer 2nd you can install **3 more Washers** under spring.

Aluminum

Washer

BLUE

Solid Spring

Spacer

RED Washer

BLUE

Small end

Big end

If the hole in the **small end** is deeper than the big end use **BLUE** spring.

If the hole in the **big end** is deeper install **Washer** and **RED** spring.

If the hole in this end is deeper than the small end install **Spacer**.

"If trans is out of the car read page 8 NOW."

3rd Accumulator: It's best to upgrade to Steel type Ford #F7AZ-7H292-AB



3rd Accumulator
Reinstall the piston, spring and retainer.

Got a broken Spring?
Ford #E0AZ-7F285-A



"It's just that easy."
Product Support
Give our technicians a call.
(626) 443-7451

READ THIS FIRST:

If the valve body *has* this partition, **STOP**. You'll need to use VB and matching plate that *does not* have partition. 1994 up.

Step 1. With 5/32" drill furnished, drill a hole thru side of VB under the "X" into the passage as shown.

Install **Orifice Cup Plug** furnished into the hole *just below* flush.

Then stake edge of hole with a small chisel to prevent plug from backing out.

LOOK HERE

Step 2. In the direction of the arrows, drill a hole thru partitions under each of the "X's".

Use 1/8" drill furnished.

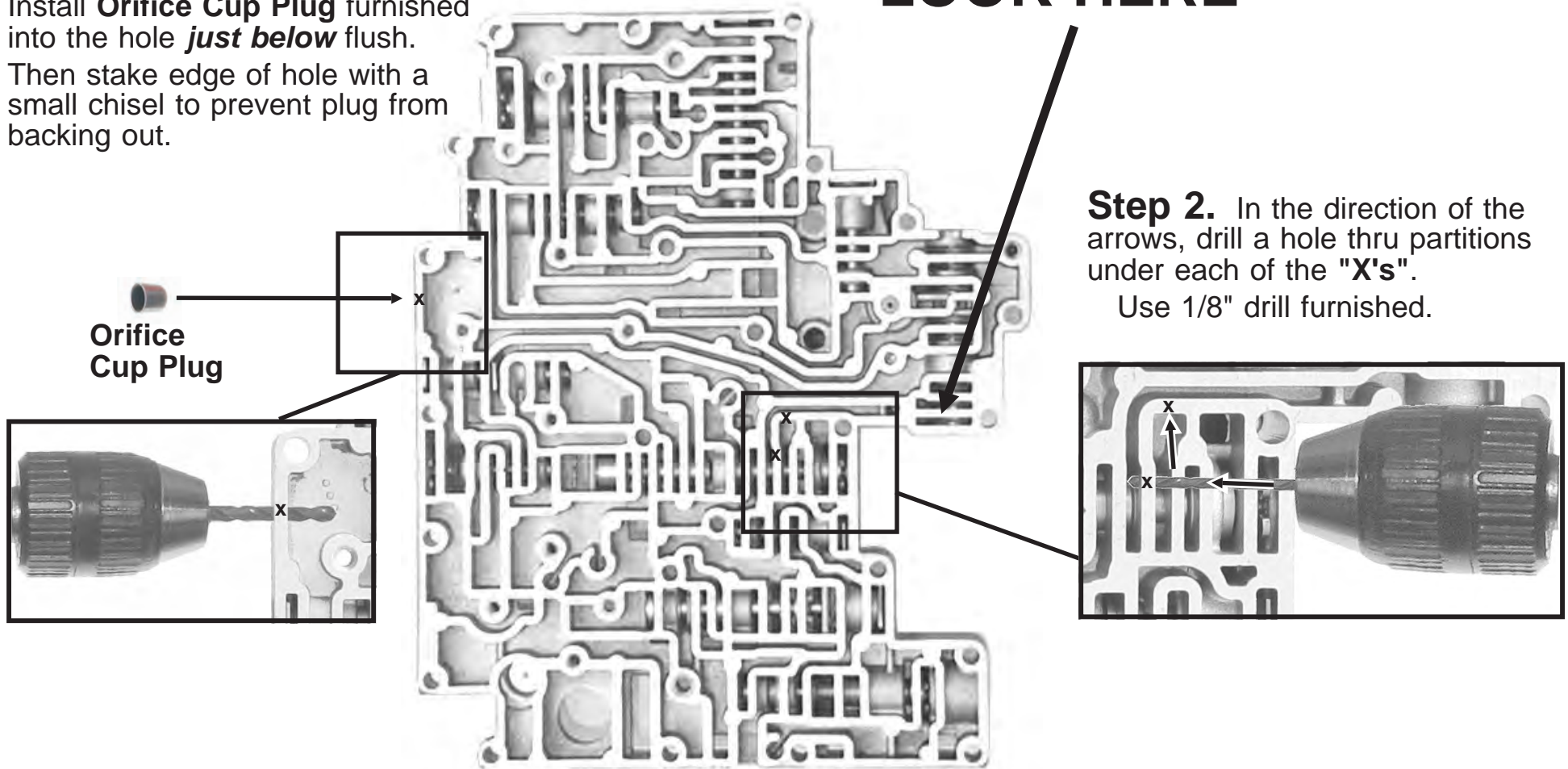

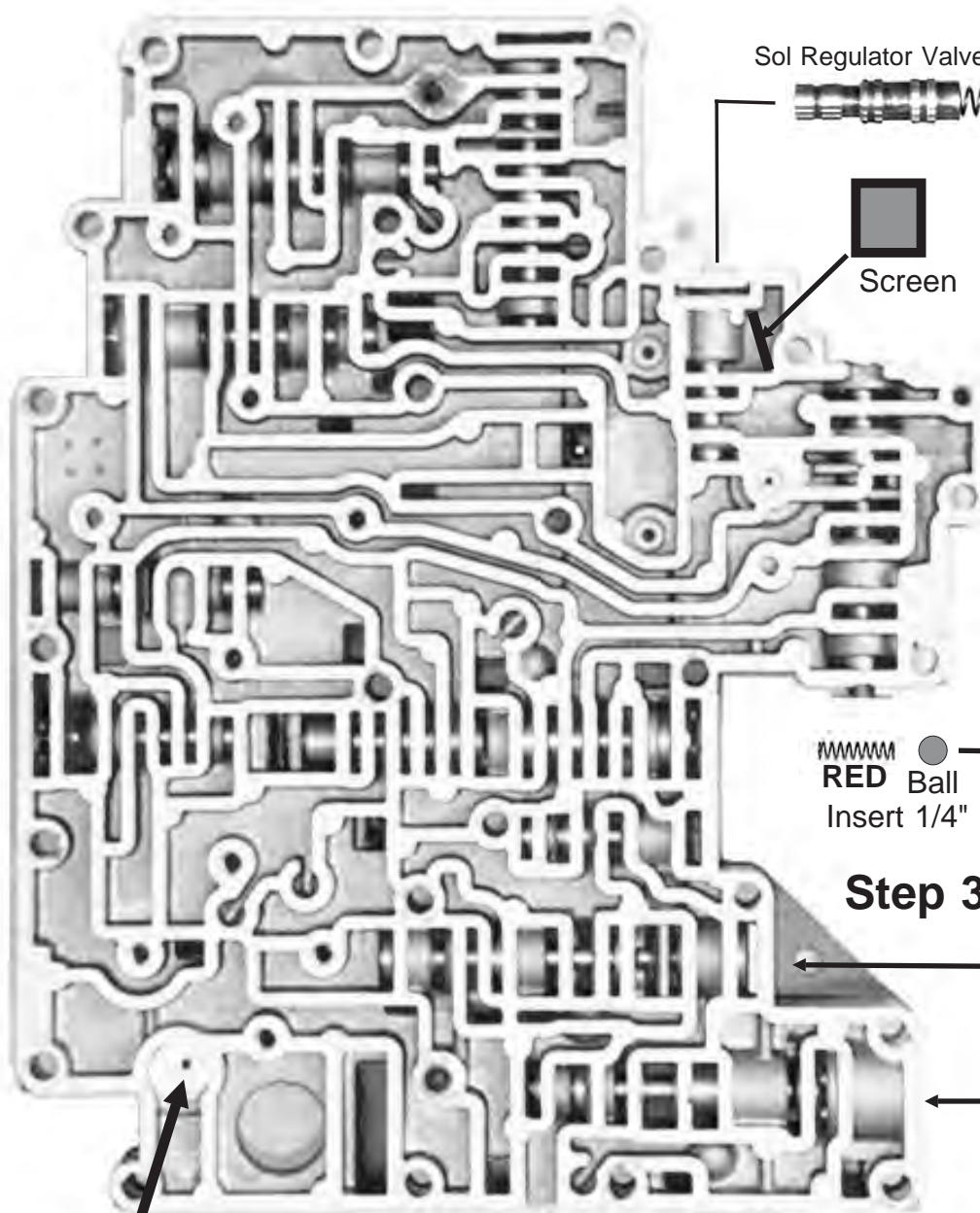

Sol Regulator Valve **ORANGE**



Step 1. Push unpainted spring furnished into open end of new solenoid reg valve. Using spring as a handle, cycle valve in and out of the bore with side pressure 50 times. The valve must fall out of the bore when valve body is tipped up. Discard unpainted spring, then install new valve with **ORANGE** spring.

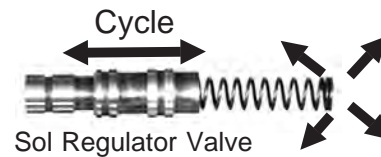

Step 2.

New 1-2 valve

Reuse spring

Reuse 2-3 valve



Insert 1/4" ball and RED spring into new 1-2 valve.

Step 3. Read Lock-Up Note first **BEFORE** using **TIGHT WOUND** spring!



Press Regulator Valve

WHITE

Step 4. Install **WHITE** pressure regulator spring.

Reuse spring [if it had one]



Drain back valve

02 Mar 2022

Lock-Up Note: Installing **TIGHT WOUND** spring eliminates lock-up function! **DO NOT** install tight wound spring if you plan on using Lock-up. Lock-up solenoid will require an additional switch. **Do not operate Lock-up at full throttle!**

Do not install ball here. (no)

Step 4.
Install new **Manual Valve**.

Step 5. Twist the **Taper Spring** onto the big end of the **Orifice**. Insert **Orifice** into solenoid snout.

Taper Spring
Orifice

Reinstall E-Clip

© CHECKBALLS
Seven 1/4" plastic

Step 1.

Install new **3-4 Valve** and **WHITE** spring.



WHITE

New 3-4 Valve

Step 2.

Low Valve



WHITE

3-4 Capacity

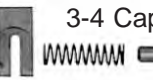

BLUE

Step 3. OD Reg Valve.



YELLOW

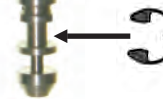
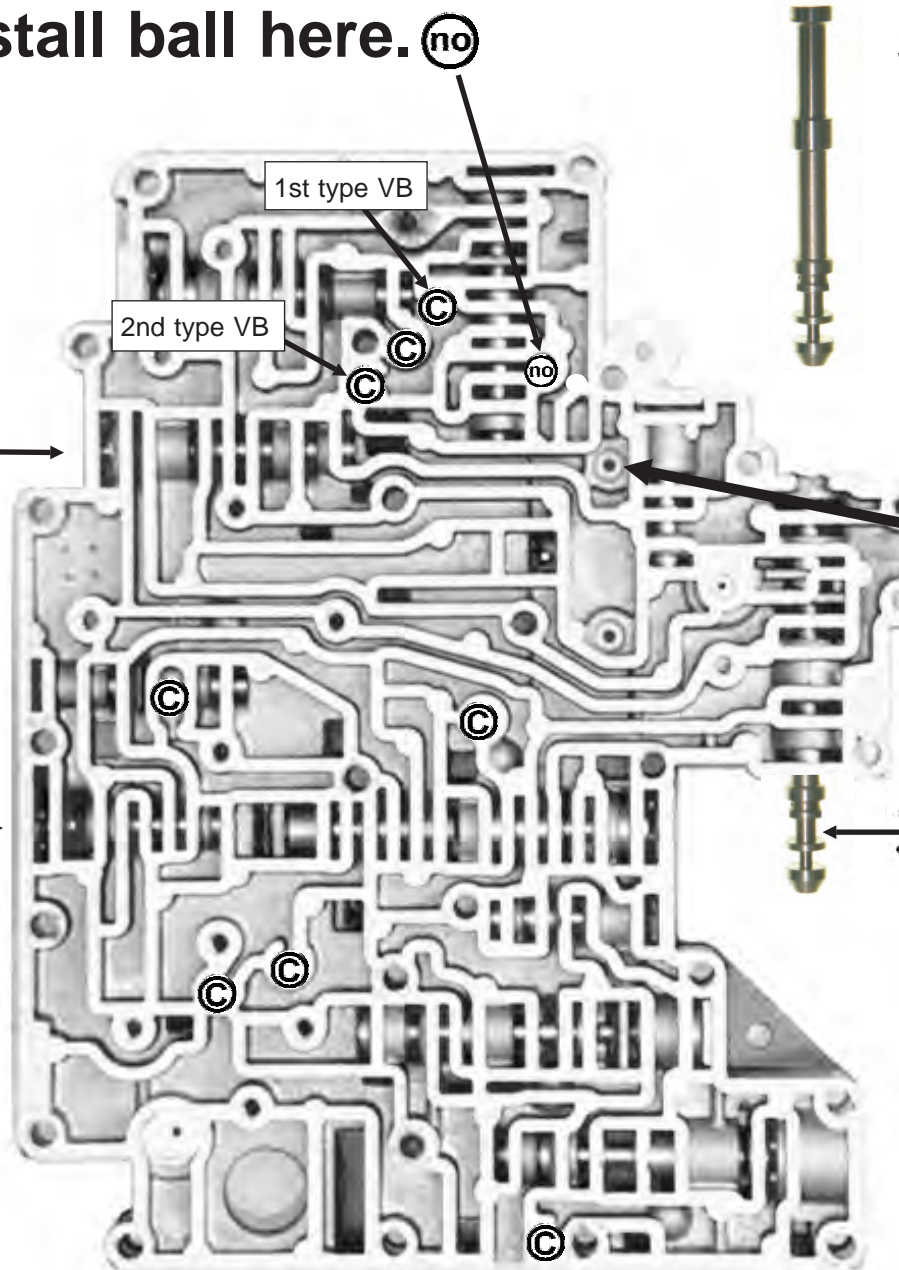

Drills furnished, actual size.



Look here: Gaskets must not cover any hole(s) in the plate.

Plate Hole Sizes

#1 = 3/32" Hot Rod with original converter

#1 = 1/8" With smaller diam high stall converter

#2 = 1/8"

Two sets of gaskets furnished:
Use the set that matches the Guide pins, holes "G1 & G2" and does not cover any holes in the plate.

Two sizes of Guide pin bolts.

.238 .171

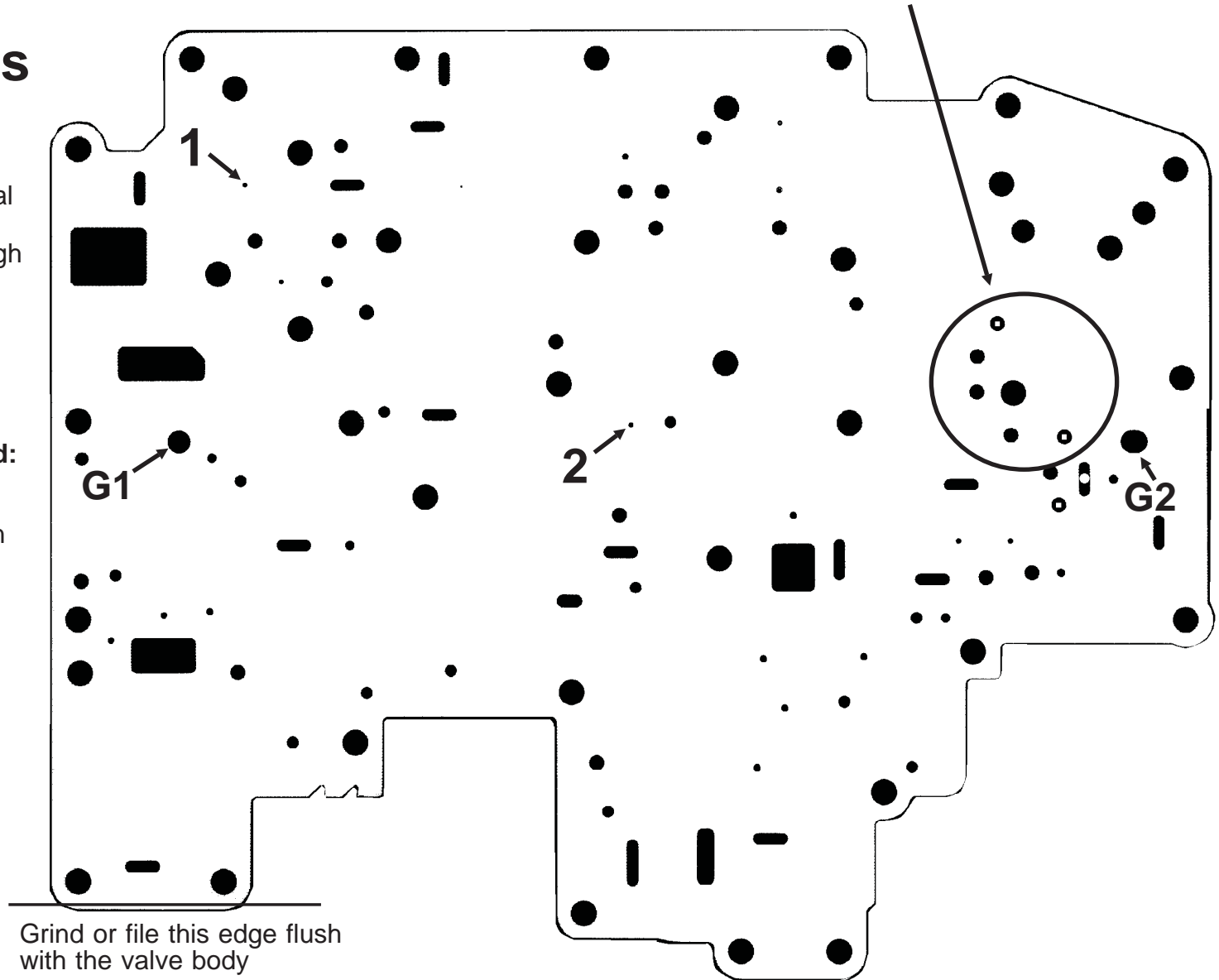

Grind or file this edge flush with the valve body

Step 1. Insert the tapered plug into this hole and pound it in flush.

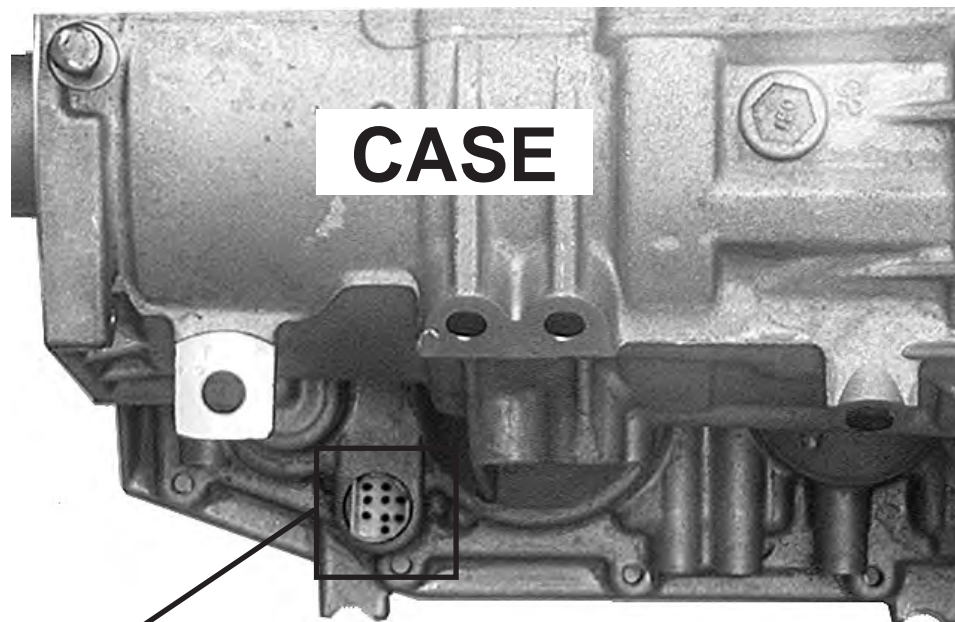
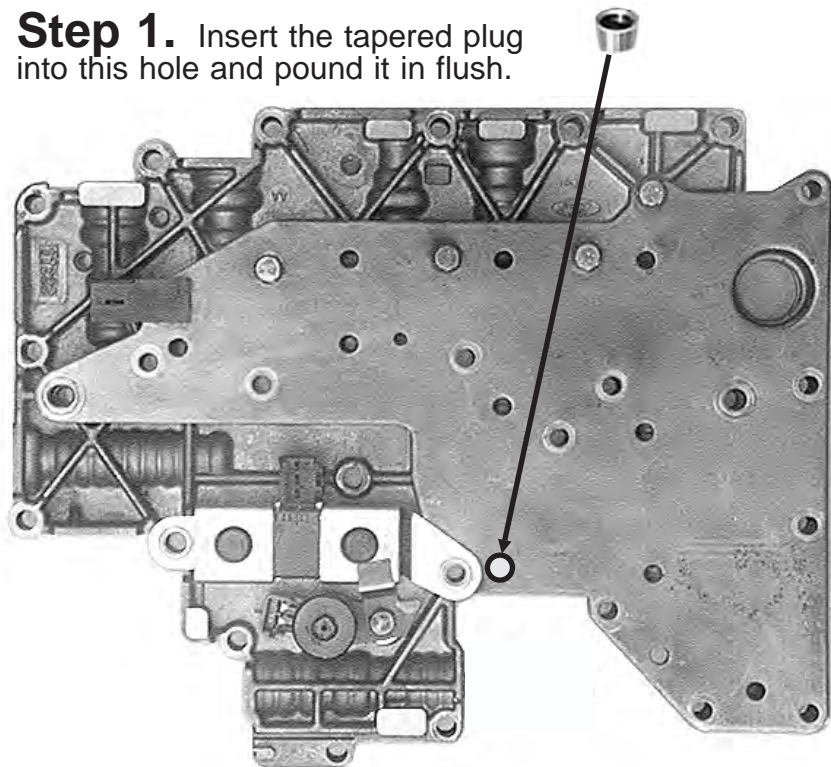

Passenger side towards rear.

Complete Vacuum Modulator Pack Before Installing VB.

Adding Lockup Control

Type 1: Splice pin "E" to ignition pin "A".

Connect pin "D" to one side of an additional switch and the other side of switch to ground. DO NOT operate Lock-Up at full throttle or high engine loads!

You **MUST USE** late type 16-22 ohm TCC solenoid to use lock-up function.

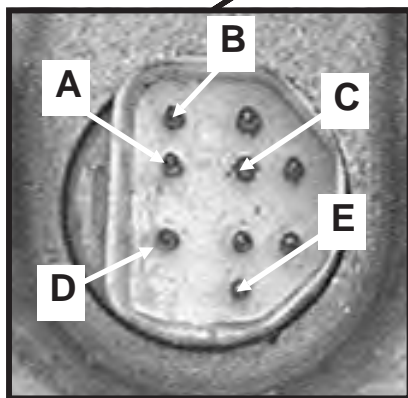

Type 1

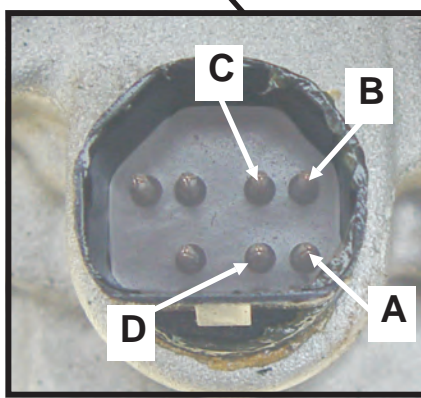

Type 2

Step 2. Driver Controlled 4th

This gives driver complete control of 3-4 and 4-3 shifts with a flip of the switch.

Connect pin "A" to an ignition switch operated 12 volt supply.

Connect pins "B" and "C" together and hook to one side of a toggle switch. The other side of switch to ground.

Adding Lock-up Control Type 2: Connect pin "D" to one side of an additional switch and the other side of switch to ground. DO NOT operate Lock-Up at full throttle or high engine loads!

You **MUST USE** late type 16-22 Ohm TCC solenoid to use lock-up function.

If trans is apart: Consider these durability upgrades

A. Assemble 2nd roller. Scribe a line on the retainer just outside the snap ring.



B. Cut four tabs about 5/16" wide in the retainer just a little deeper than the scribed line. Then bend tabs up.

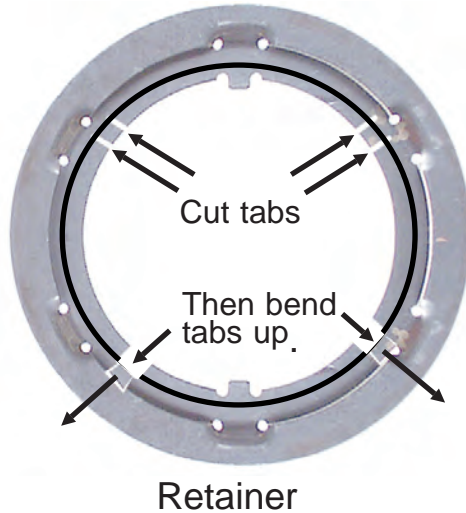

C. 1. Install the snap ring by rotating it into the groove inside of the tabs.
2. Bend the tabs over the snap ring to keep it from jumping out of the groove.

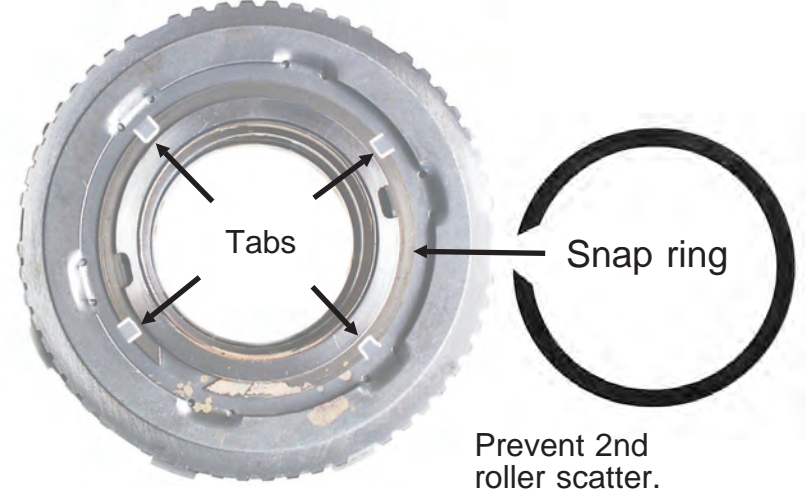

If the old band is severely burned or worn out check the 4th servo pin bore in the case for wear.

4th band

To insure a quick/full band release during 4-3 kickdown reshape band across its mid portion as shown below.

Leave first 5" on both ends of band as is.

Original shape

Reformed shape

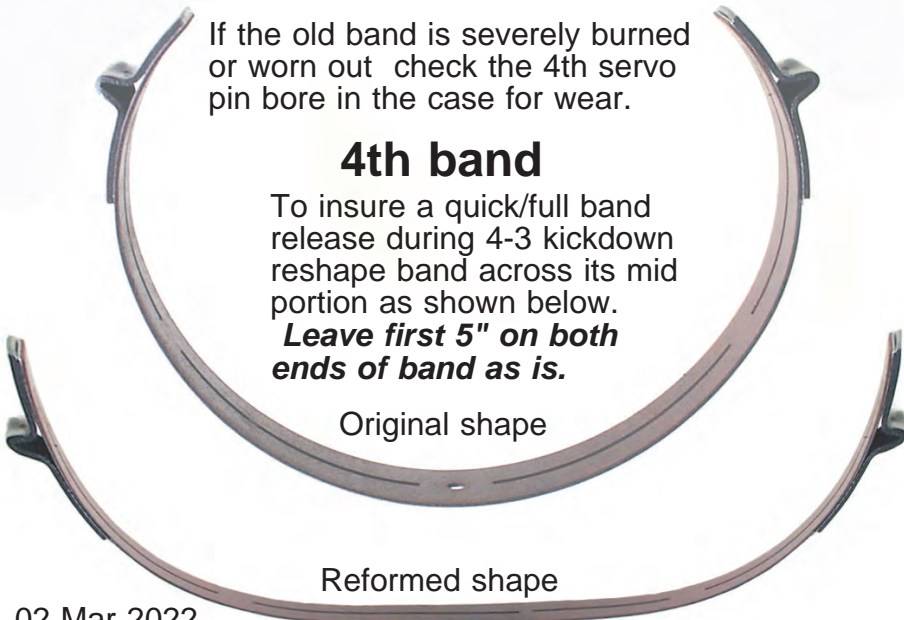

D. Special new plastic forward clutch rings have slight chamfer on one side. Install rings with the chamfer as shown.

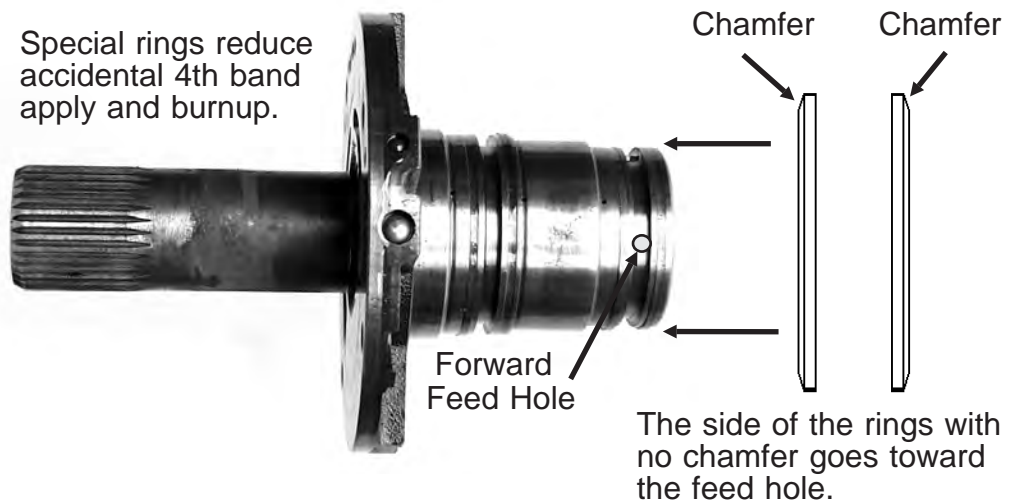

AODE-MOD

AODE- 4R70W Vacuum Modulator System



Step 1

Center punch the center of the marked X. Drill an $1\frac{1}{32}$ " hole **straight** into center spot. Tap hole, from this side $\frac{1}{8}$ " NPT.

Step 2

Install **FITTING** into the case with some sealer.

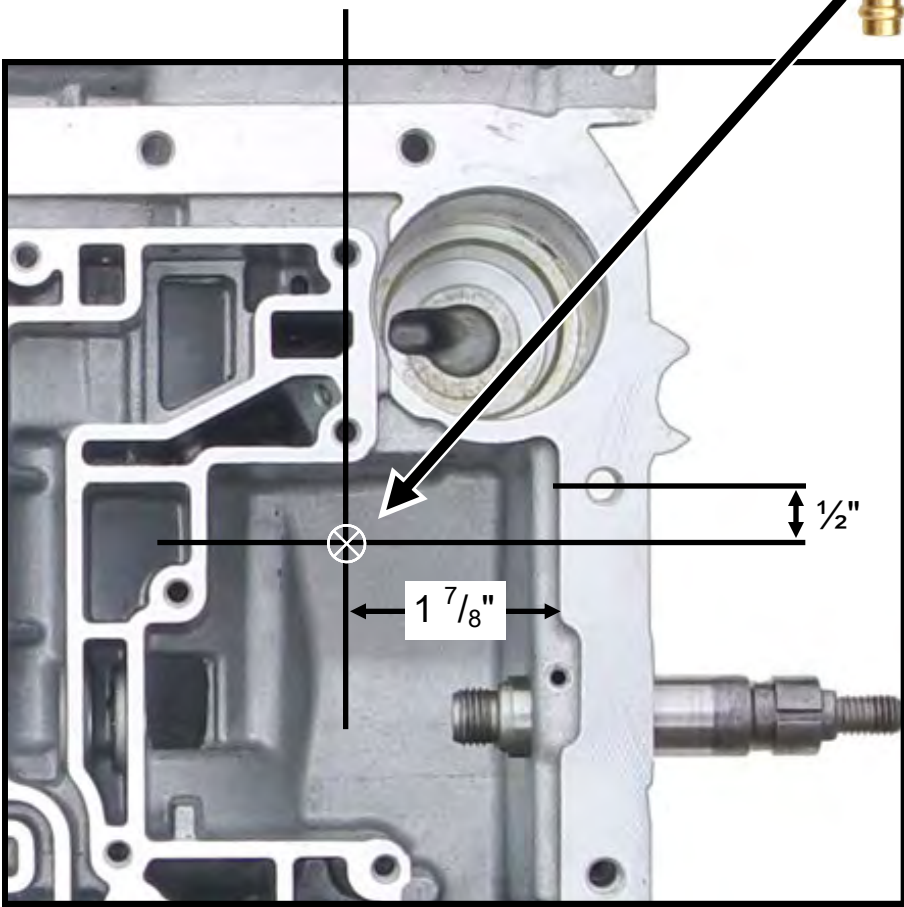
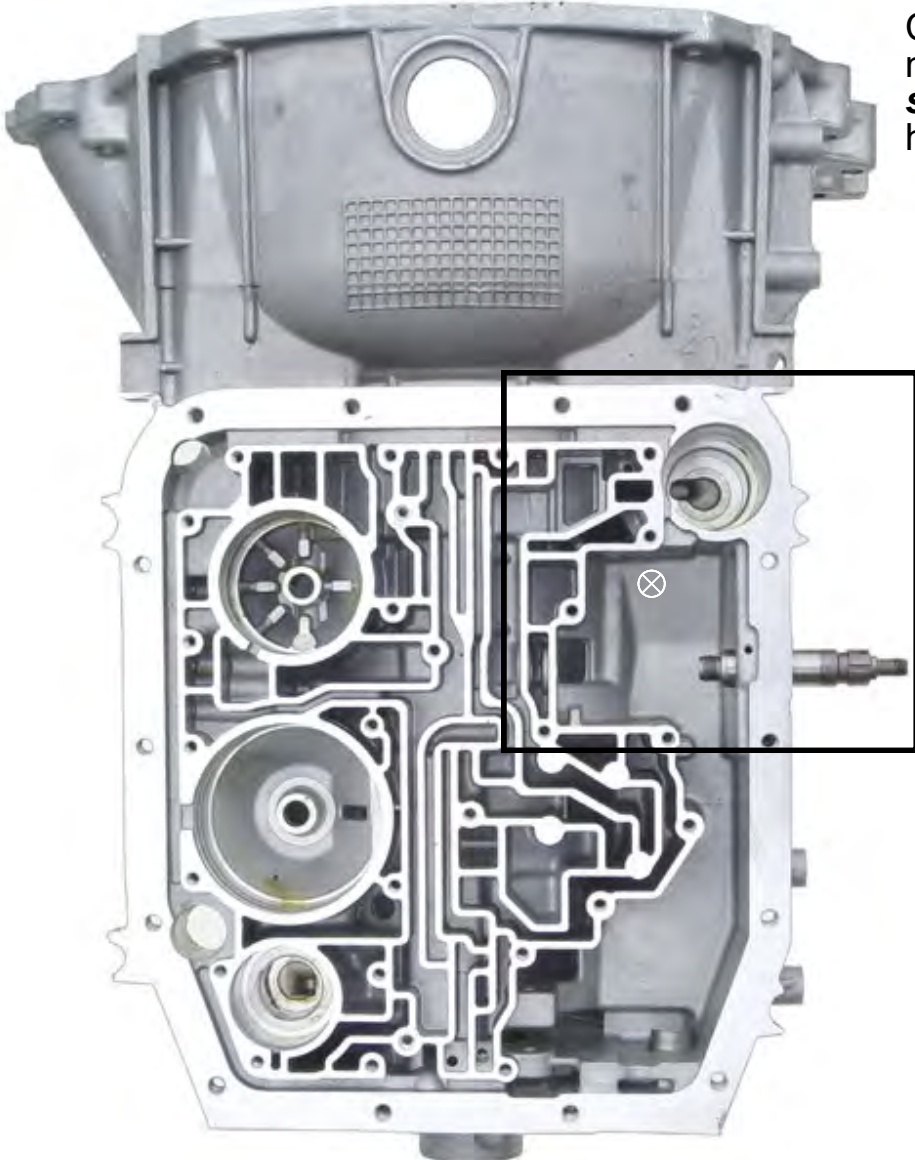

Step 1

Place the **HOSE** on this picture and cut it to match picture.



Step 4

Assemble Bushing, Valve, Pin, Modulator and Spacer into case. Install Skinny **SILVER** Spring into the modulator **tube**. Install **HOSE** over **skinny spring**. Install zip tie on hose end.

Step 2

Slide **HOSE** on fitting in the case. Install zip tie.

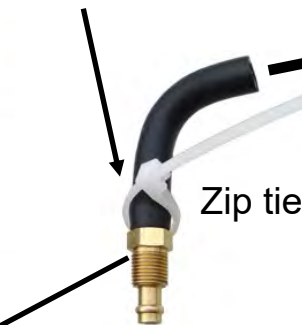
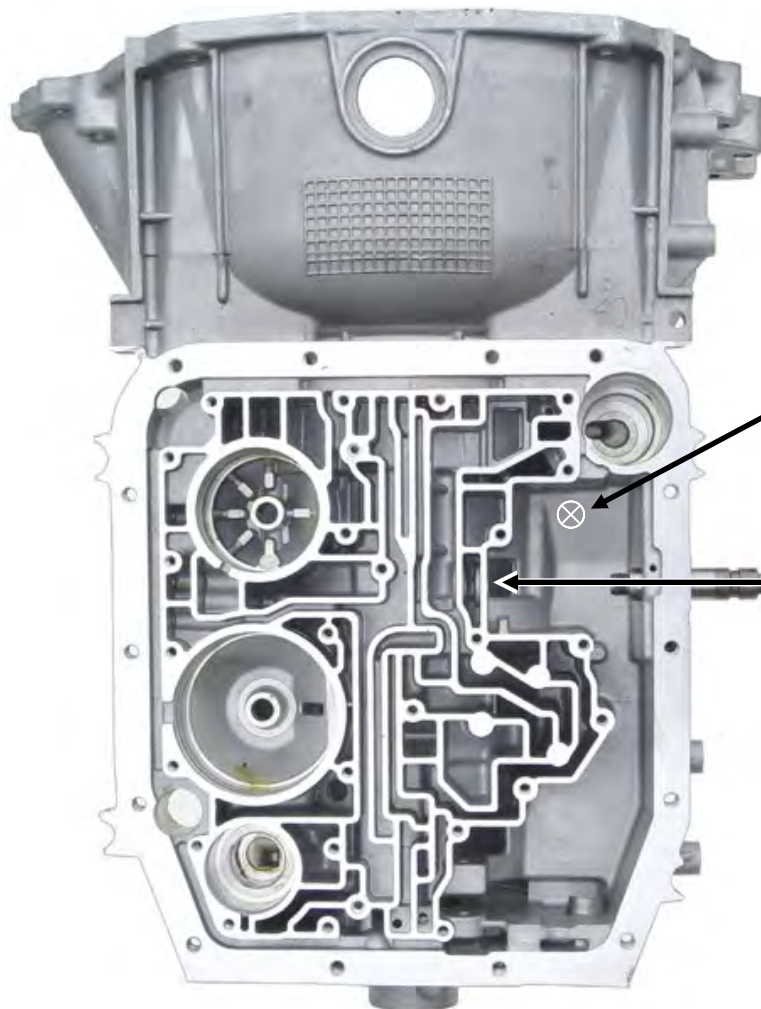

Zip tie

Step 3

Modulator pin length starts at prox 1.405. You **MUST** grind the pin to one of the following:
Street/Strip Hot Rods 1.365
Show/Mild Street Rods 1.325



BUSHING VALVE PIN

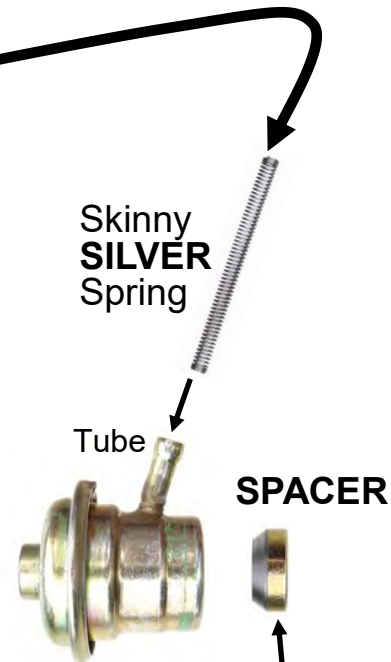

Skinny **SILVER** Spring

Tube

SPACER

Use Vaseline to hold spacer. Tapered end toward Mod.

Vacuum Line Installation

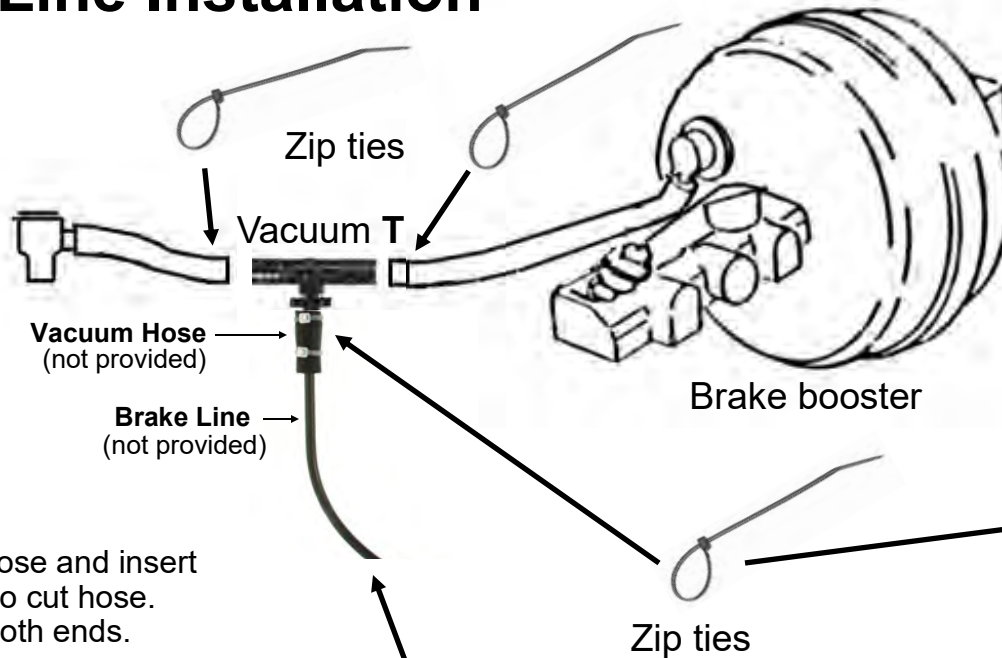

Turbo or Supercharged Engines Must Have pressure bypass. Install **TransGo VBP-VAC** bypass kit into modulator hose.

Step 1

Cut power brake hose and insert large end of tee into cut hose. Install zip-ties on both ends.

Step 2

Using 3/16 Brake line and 2 short pieces of vacuum hose (not provided), route brake line down to modulator case fitting. Use enough line to comfortably reach within 1" of both the vacuum brake booster Tee location and the case vacuum fitting. After determining correct length that will allow you to secure the line and reach both fittings, cut the brake line and swedge both ends to prevent vacuum hoses from slipping off. Install a short piece of vacuum hose on each end and secure lines and hoses with Zip-ties.

