

# RE5R05A-HD2 REPROGRAMMING KIT™ High Performance

This Kit Fits: JATCO 5 Speed Rear Wheel Drive & 4WD Models  
(Does not fit Front Wheel Drive JF-506E models)

**Short, Firm Shifts with Performance, Durability and “CLASS”**

## **HOLD IT! READ THIS BEFORE STARTING!**

The Installation of this product **REQUIRES A PROFESSIONAL AUTOMATIC TRANSMISSION TECHNICIAN.**

**DO NOT ATTEMPT** to do this installation on your own! We **DO NOT** furnish technical help to general mechanics, do-it-yourselfer's or anyone else **NOT FULLY EXPERIENCED** and **EQUIPPED** to handle the diagnosis, overhaul and drive-ability for the RE5R05A Transmission.

**To the Technician:** Perform a thorough road-test and scan the system for codes before starting. It is important to address any engine or transmission performance problems **BEFORE** attempting the installation of this product. If the car has been driven hard for very long with added horse power the friction materials may already be damaged, overhauling will be required. This product **REQUIRES** a good working transmission before installation. Use extreme care in handling this valve-body assembly as the solenoids are **FRAGILE** and at this time can **NOT** be ordered separately. Avoid applying pressure to the valve body with the solenoids **CONTACTING** the bench! If you accidentally damage a solenoid the only current solution is to purchase a new valve-body assembly from the dealer. **DO NOT DIP OR SOAK THE COMPUTER (If attached to the Valve-body) IN SOLVENT!**

Before beginning **READ THE INSTRUCTIONS THOROUGHLY!** There is additional information included to help you identify bolt locations for removal and disassembly purposes. Call us with **ANY** installation questions you may have.



You'll just Love it.



© TransGo 2007

## READ THIS BEFORE STARTING VALVEBODY!

The Installation of the Valve body parts and tech starts on the next page. Always do **Step 1 on this page** first before proceeding with the Valve Body parts and tech installation. If you need help removing and disassembling the VB, read below. Otherwise do **Step 1** on this page and proceed with the installation on the following pages. **DO NOT SOAK or wash the computer in solvent if there is one attached to your Valve-body!**

**Do NOT bump solenoids they are fragile!**  
**There are NO replacements available at this time!**

### VB Removal Help:

Follow the separate Valve Body (VB) removal booklet for bolt ID and procedure tips for removing and disassembling VB. Keep it and VB clean! Reverse procedure to reassemble and reinstall VB back into the transmission. You'll need a caliper that measures in inches to measure bolt lengths.



The following chart lists the bolt lengths according a letter code we assigned. You may find measuring each bolt as they are removed and recording them next to the illustration in the removal booklet an added "safety" should the manufacturer change any bolt lengths from the models we have illustrated in the booklet.

### Letter Code To Bolt Length In Inches

Code	Length	Code	Length
A	1.80	F	1.74
B	2.33	G	0.85
C	1.65	H	1.56
D	0.65	I	1.88
E	2.80	J	2.13

**Step 1** With a flat punch and a light hammer, tap tapered orifice into hole shown just below case surface.

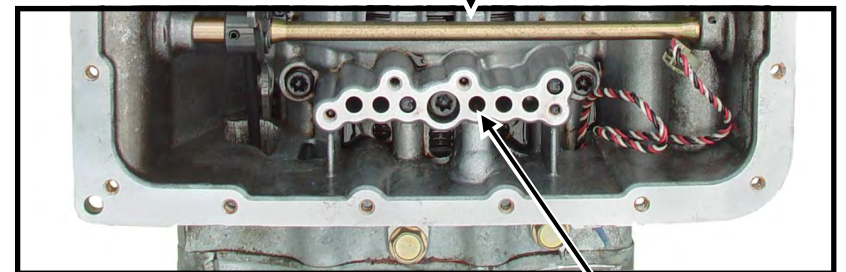
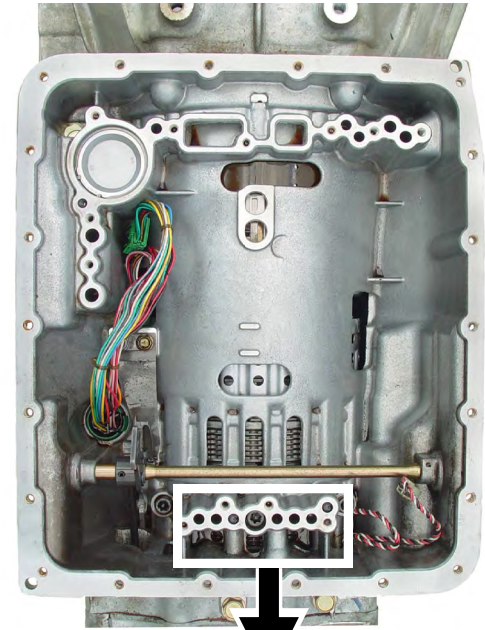

Tapered Orifice  
Location

**Step 2** Working with one valve at a time, remove original valve and match it for size to one of the new valves provided. *Install new valves, springs and check balls exactly as shown.* Always insert ball first into hollow end of new valve then spring. Make sure small end of new inner spring faces ball! Insert the new valve, ball and spring as an assembly into VB, then install outer springs, plugs and retainers as required. **See below for each specific valve assembly requirements.**

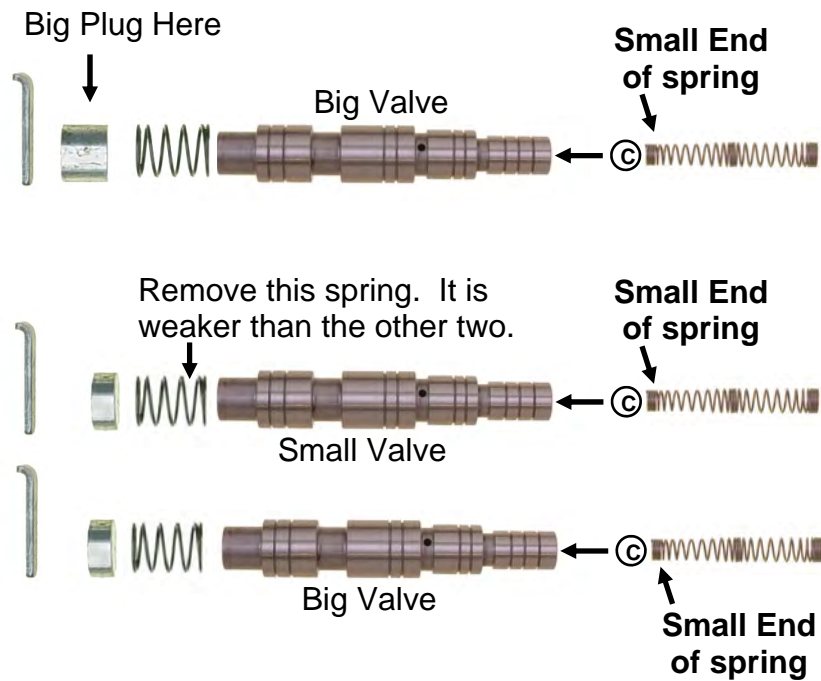

Main VB

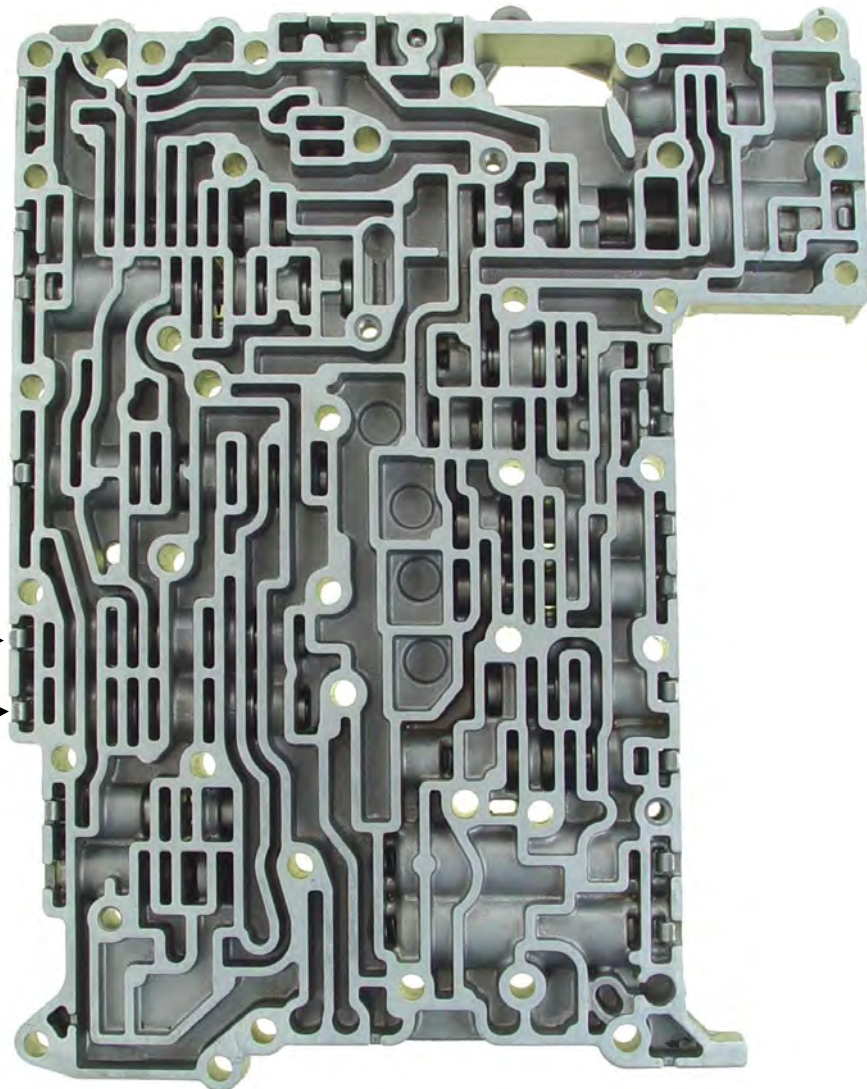

**Experience Tip:** Be safe! Save all old parts and discard them only after your sure everything is ok. **Always keep the instructions.**

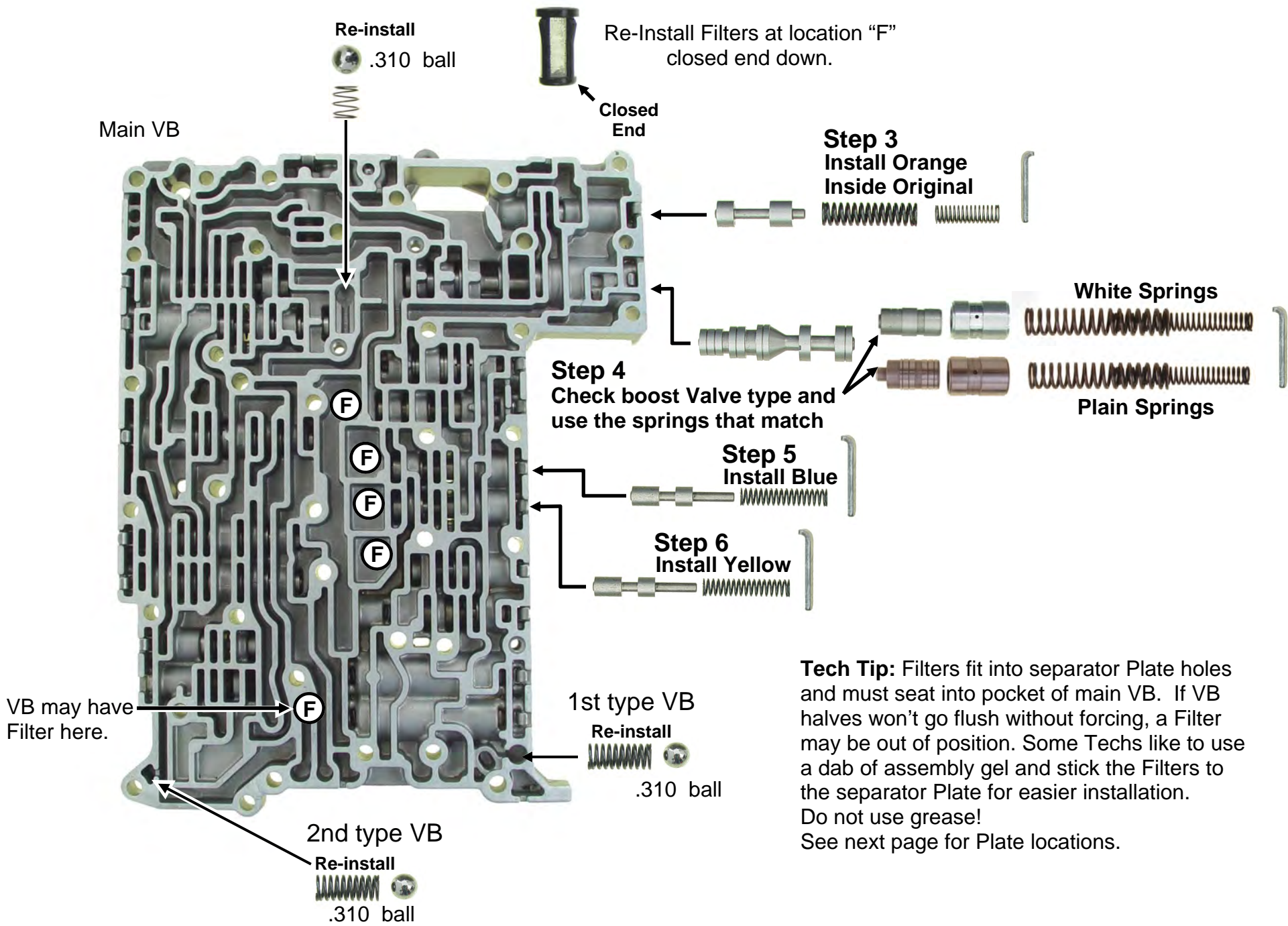

**Step 7**

**Plate Hole Sizes:**

Holes A,B & C drill to .103

Holes D & E drill to .125

Hole F drill to .136

Hole G drill to .110

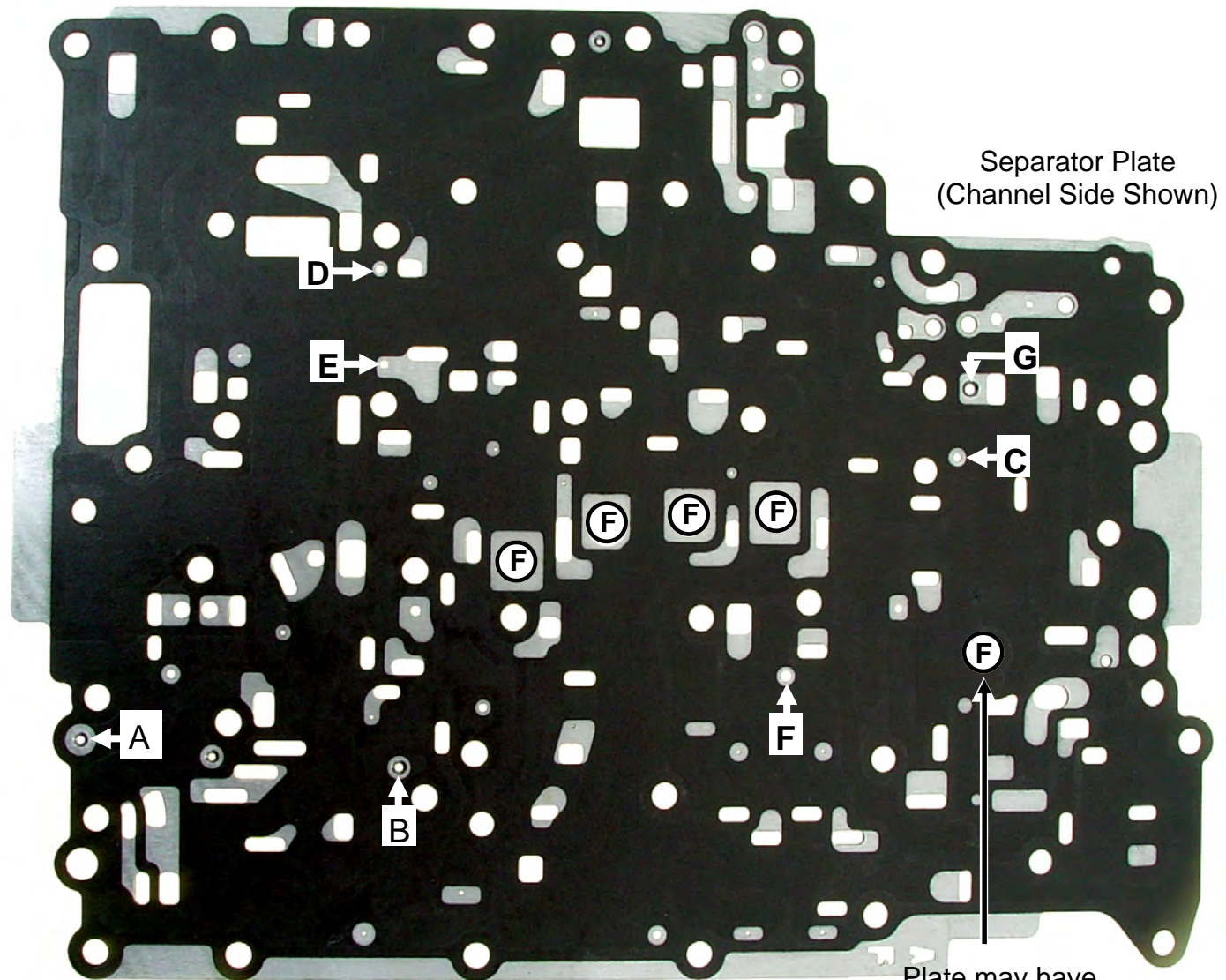

## Step 8

Re-Install check Balls for type VB you have. There are no check Ball changes being done as part of this Kit. All locations are factory placement and count. You're done! See assembly booklet for help getting the bolts back in the right locations.

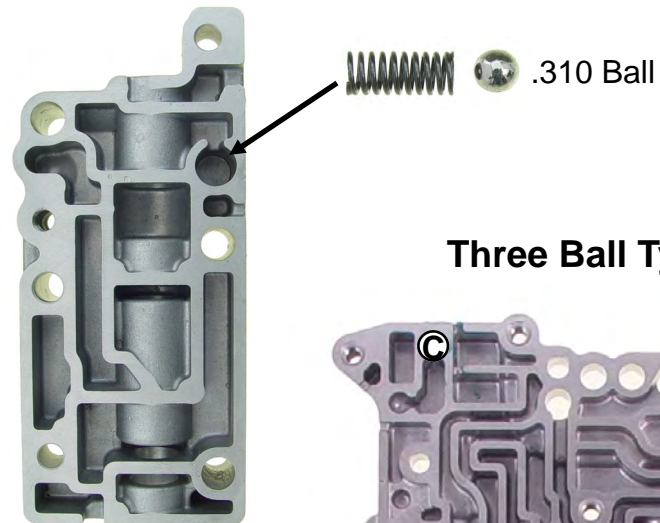

**Five Ball Type ©**

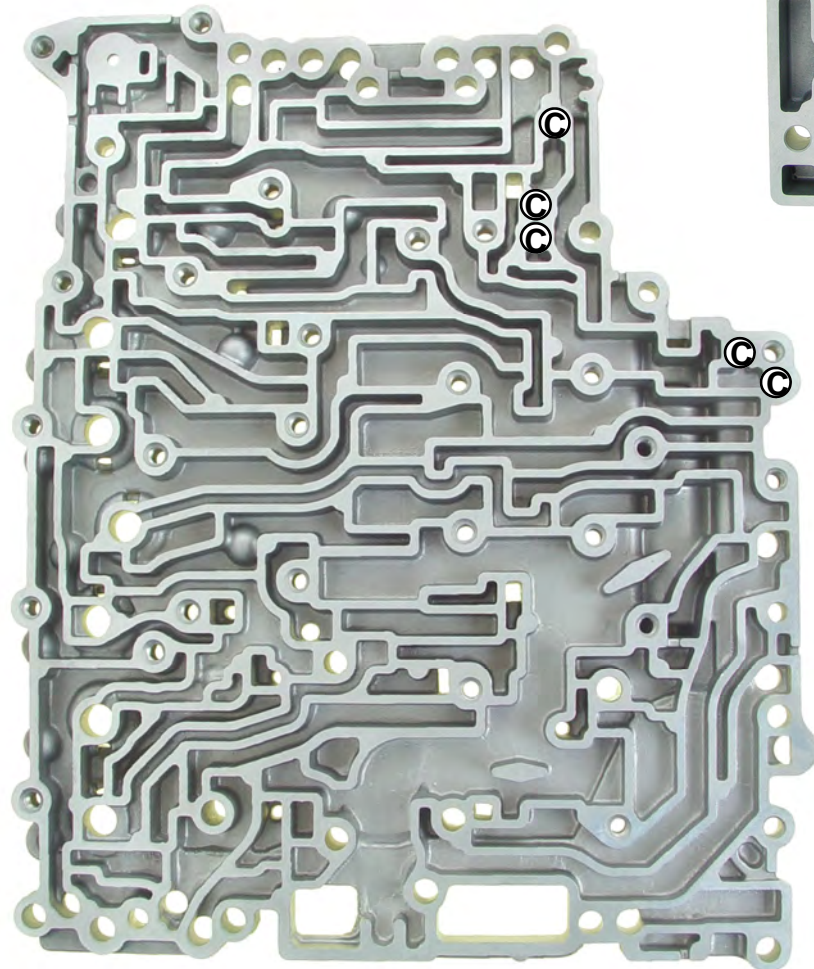

**Three Ball Type ©**

