

A750-NTA No Tool Refill Kit.

Corrects/Prevents/Reduces

Shuttle, Bind-up or Flair on 2-3 Shift, Slips with throttle in 3rd and/or 4th, TCC Codes & Rough KD at Highway Speeds due to slow TCC release.

Refill fits 1 of 5 VB Types!

Need Tools? Order SK® A750-WTA

Fits: Toyota: A750E/F 5 speed
AB60E/F 6 speed
Lexus: A760/761 E/H 6 speed
A960E 6 speed



Identify Valve Body First!

Follow Pages that MATCH your VB Type

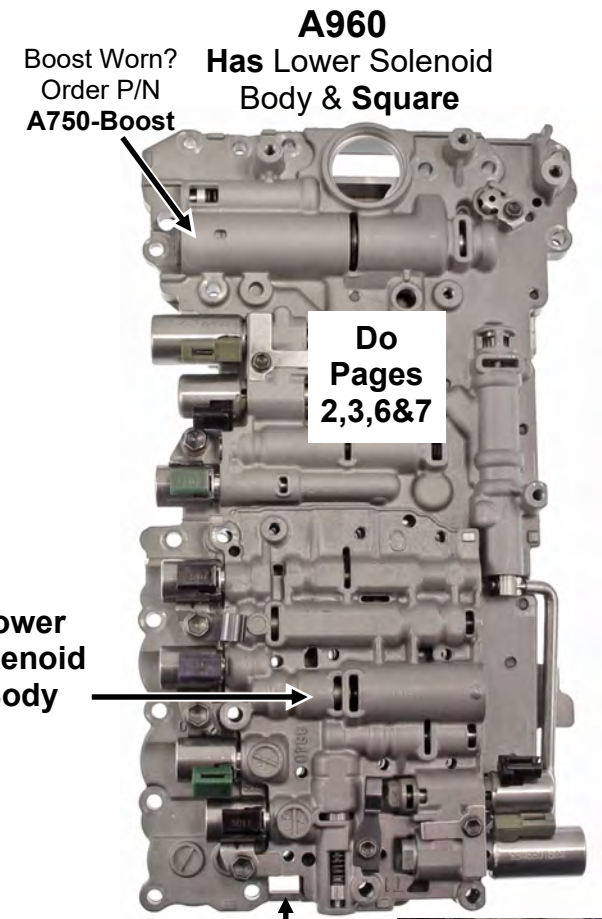
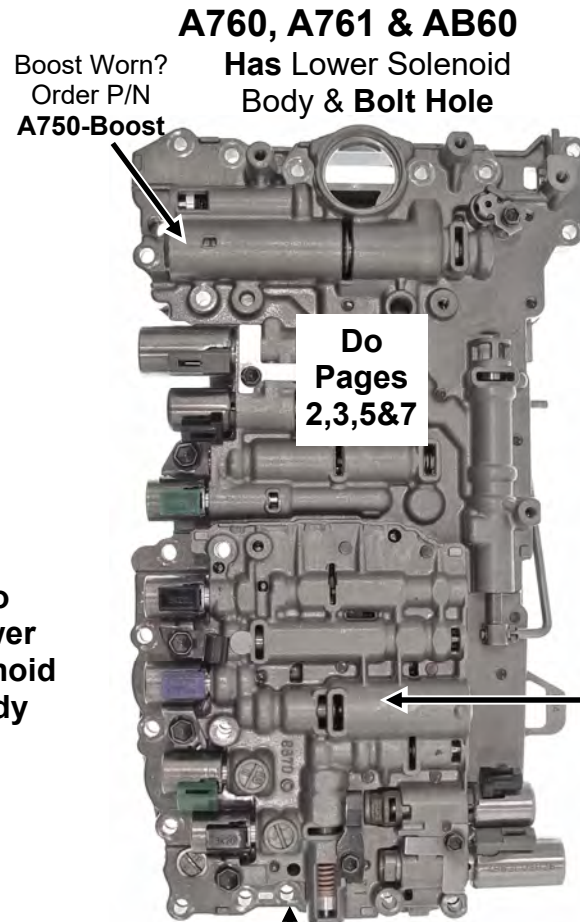
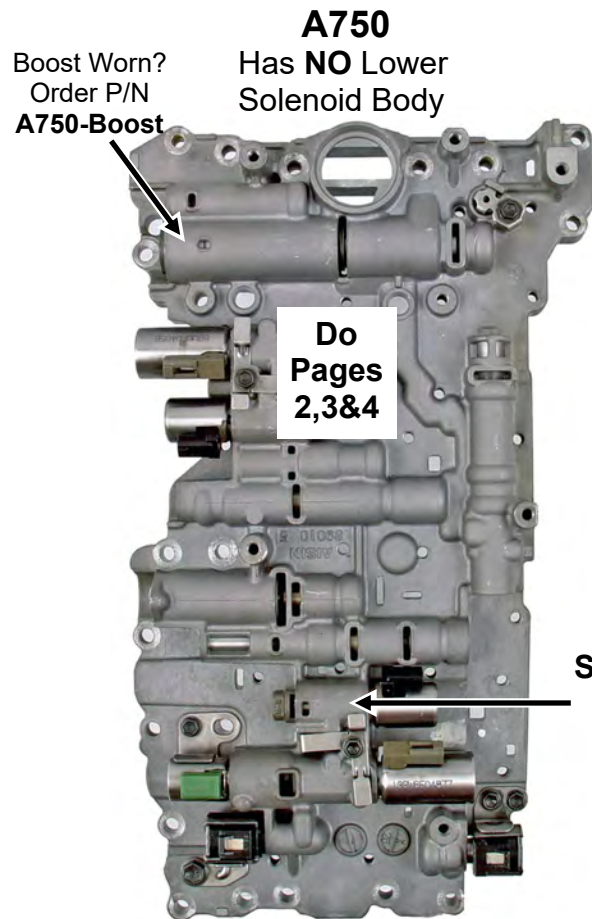

Warning! Record ALL checkball locations during disassembly. IF ANY CHECKBALL LOCATIONS ARE DIFFERENT from what we show ALWAYS re-install check ball's as you found them! Shown in this kit are the typical locations that we are currently aware of. There may be other variations.

Main Plate Updates (FOR ALL MODELS)

Step 1

Enlarge Hole "A" & "B" with the .055 drill provided.

A750

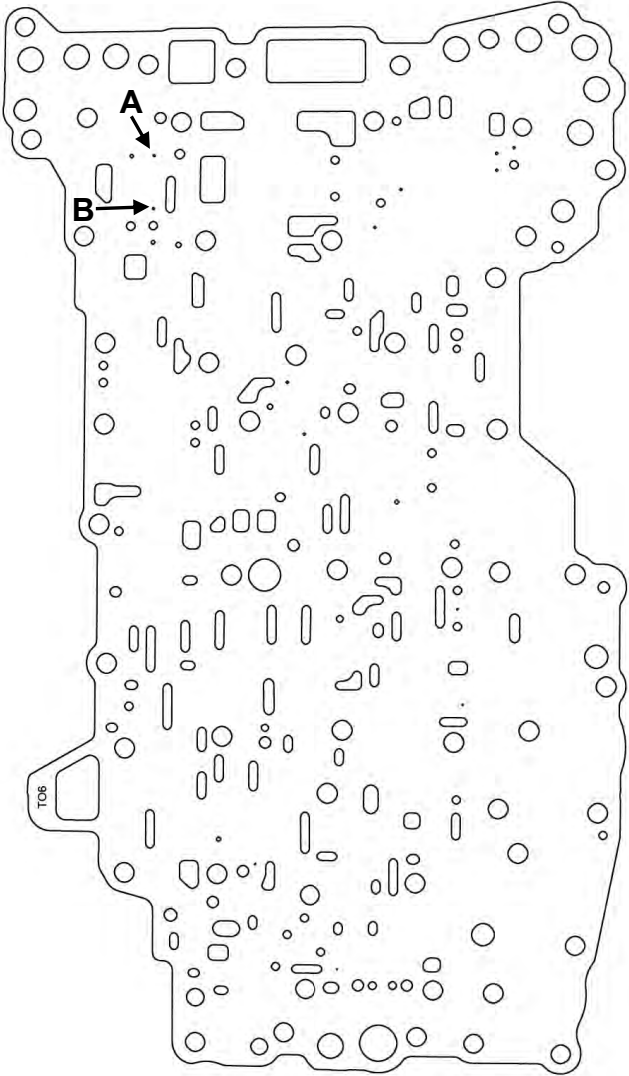

A760, A761 & AB60

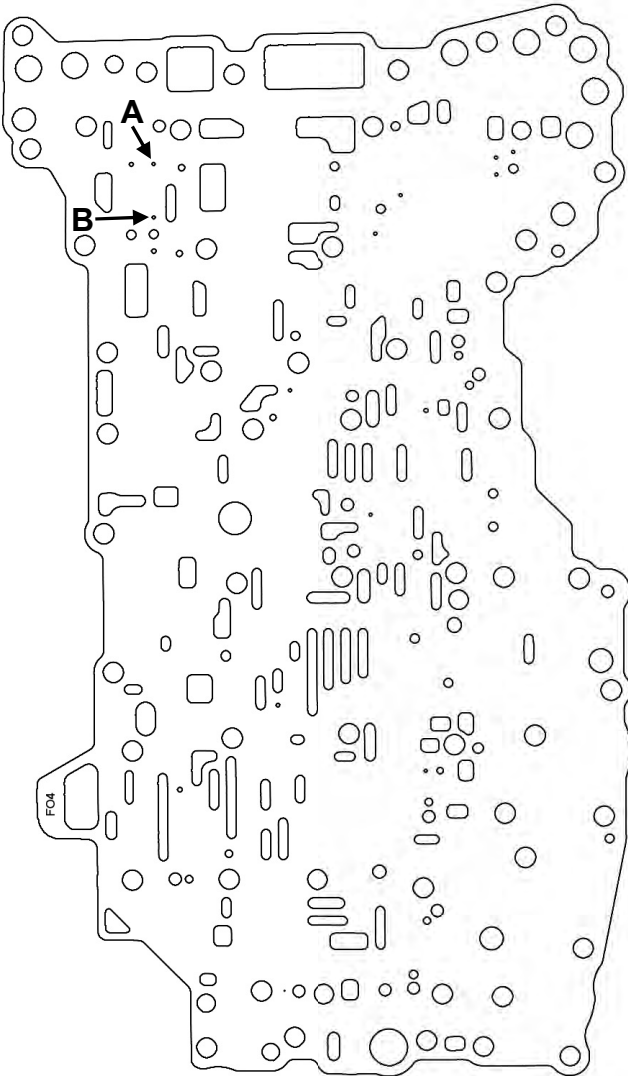

A960

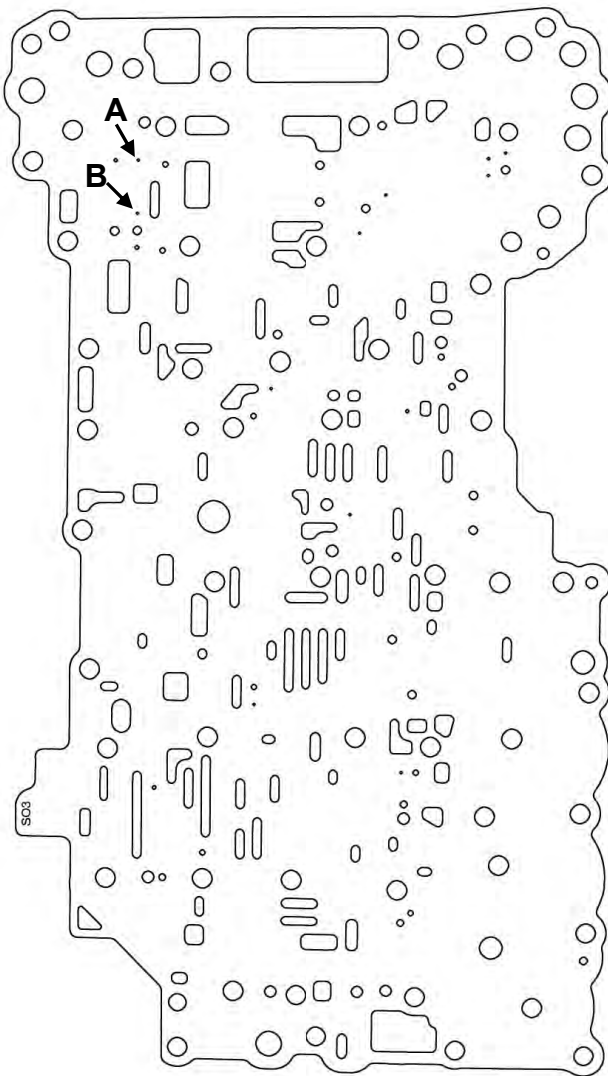

Previous Design TCC Relay Valve Repair

Use this page for reamers having 2 different diameter cutting edges!

Reamers with 1 diameter cutting edges use next page (Page 3-Updated Design)

Upper VB - Bottom View
(750E & F shown)

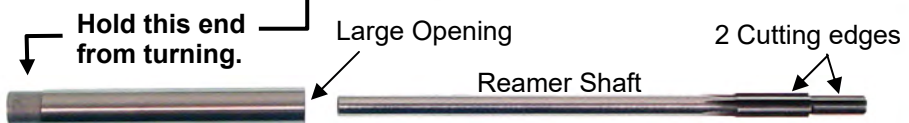
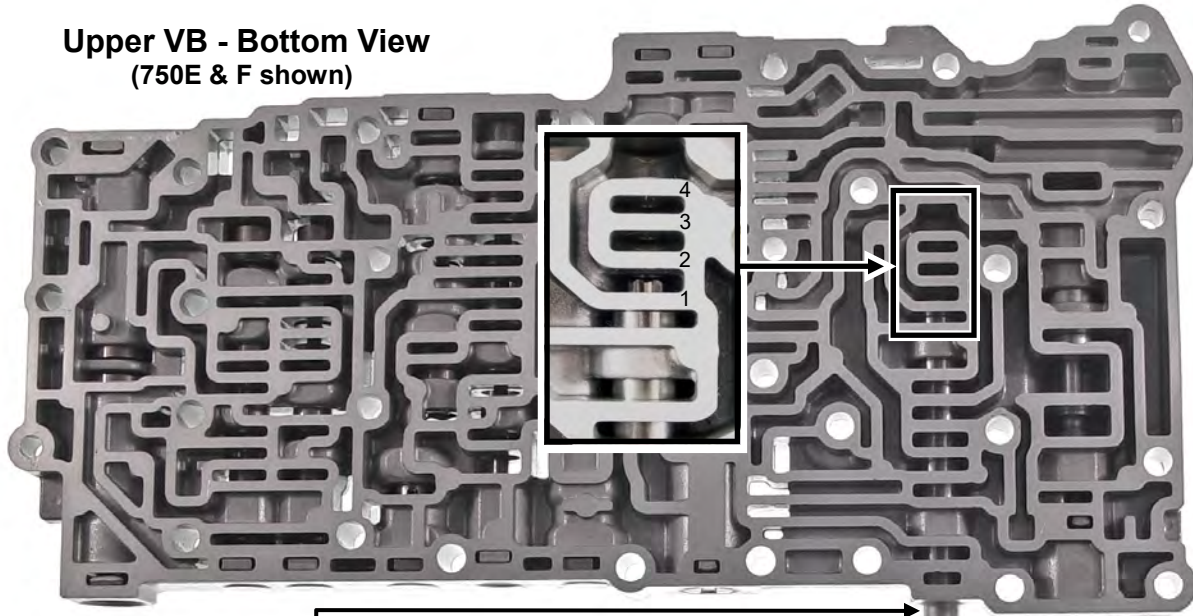

Clean and Lube reamer and guide bushing before using. Insert shaft of reamer into large opening of guide. Hold guide on stepped end with vise grips clamped just enough to keep guide from turning.

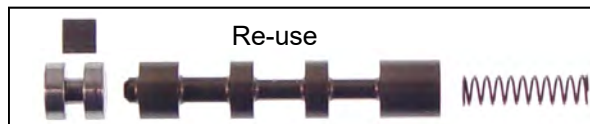

Step 1. Remove & discard old inner TCC Relay Valve. Install NEW inner TCC Relay Valve **after** bore has been reamed and cleaned in **Step 2**.

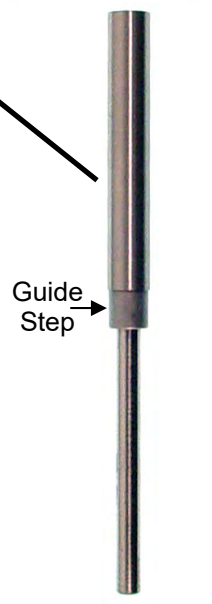

Assembled Reamer

ALL MODEL VB's- Read This First!

Your feedback has enabled us to improve the design of the TCC Relay Valve. Our **UPDATED bushing and valve design** now works even in a severely worn valve bore.

We are phasing out the previous design.

This version of parts refill contains 1 **old design AND 1 new design** set of parts to match new or previous versions of tools.

Use **Page 3** if your reamer has 2 different size cutting edges. (Previous Design)

Use **Page 3-Updated** if your reamer has a single size cutting edge. (Updated Design)

New Design Inner TCC Relay Valve, Bushing & Retainer



New Design TCC Relay Valve & Bushing **requires** the use of **NEW Tools** found in the **Updated SK® A750WTA Kit**.



Step 2.

Insert guide bushing and reamer into bore until bushing bottoms out. Install locking pliers on guide step, **just snug**, to keep bushing from spinning. Turn reamer **at a slow speed** with drill motor. Use light steady pressure while reaming, do not use force! You can use ATF or Motor oil to lube reamer but cutting oil works best. Turn valve body over to blow out chips and rinse bore clean! New inner Relay Valve should move freely in the bore.

Updated Design TCC Relay Valve Repair

Use this page with SINGLE diameter cutting edge reamers.

New Bushing Retainer must install just below VB surface in this location. Grind top of retainer if needed.

Clean & Lube Tools Before Each Use.

Upper VB - Bottom View
A760 (AB60) shown

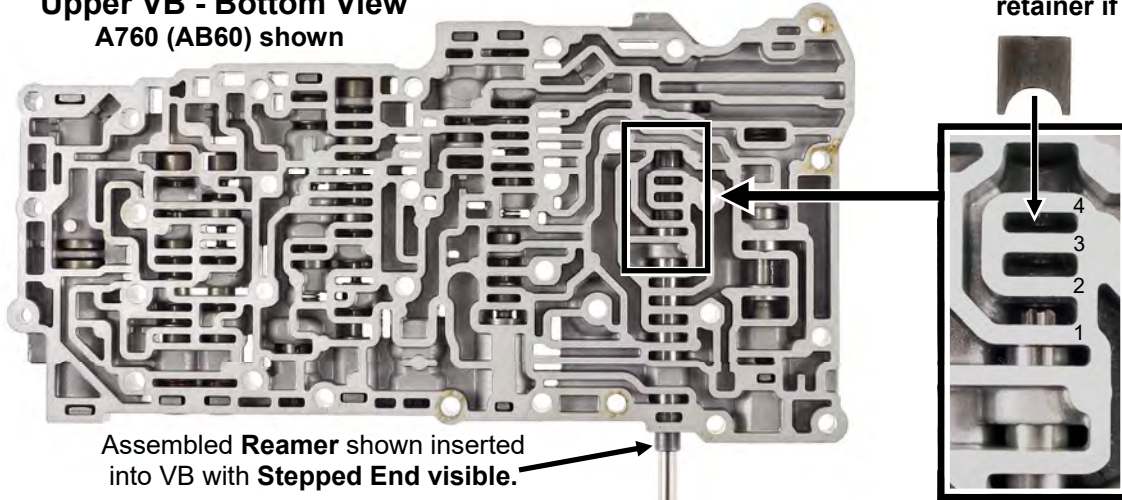

Assembled Reamer shown inserted into VB with Stepped End visible.

KITS WITH SEPERATE NO-STEP DRILL GUIDE
Used for drilling only! Ok to use either end.

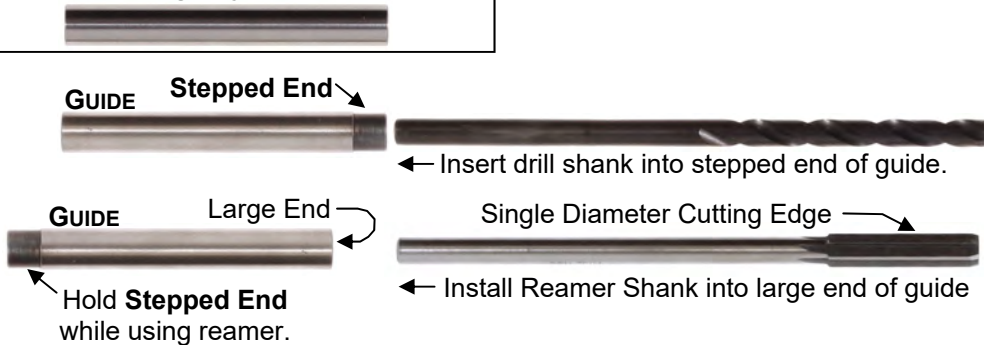

Step 3. Clean & Install **NEW Inner TCC Relay Valve** into **New Bushing** and insert into bore. Install **New Bushing Retainer**. Install original spring, outer valve, end plug & original retainer.

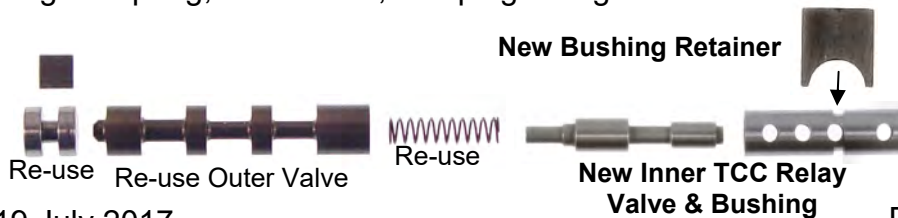

Step 1

1a.) Remove & discard original **inner** TCC Relay Valve. **SAVE** the spring, outer valve, end plug and retainer for re-use.

1b.) Insert **shank** end of large drill into the **stepped** end of the guide bushing and attach to a **slow speed drill**. (**If your kit** included a **separate "No-Step"** drill guide, use either end of it and go to **Step 1c.)**

1c.) Insert guide and drill bit into bore. Slide guide in until it bottoms out. Now drill **slowly** and count the 4 walls you will need to drill through. (If drill guide spins it's ok) **Stop after going through the 4th wall!**

1d.) Remove tools & blow out the chips.

Step 2.

Insert reamer shaft into **large end** of stepped guide bushing. (The **side** without the step.) Insert into VB bore until bushing bottoms out.

LIGHTLY hold stepped end of guide bushing with locking pliers to prevent rotation of guide bushing. Turn the reamer **at a slow speed** with drill motor.

Use very light steady pressure while reaming, do not use force! You can use ATF or Motor oil to lube reamer but cutting oil works best.

The slower you do this step the better! Stop drill motor after reamer goes thru 4th wall. Flip valve body over and blow out the chips. Rinse bore clean.

Tools ready for use.

A750 VB Section

Warning! Record ALL checkball locations during disassembly. IF ANY CHECKBALL LOCATIONS ARE DIFFERENT from what we show ALWAYS re-install check ball's exactly as you found them!

Shown in this kit are the typical locations. There may be other variations.

Step 1

Remove & Discard Original Sol Reg Valve, Spring & Plug. Install New Bushing, Valve, Orange Spring & New End Plug. Re-use original retainer.

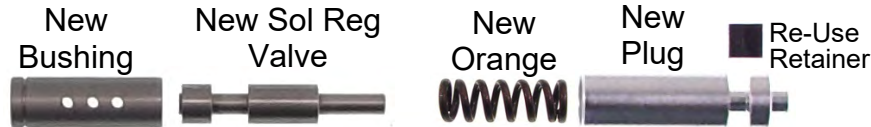

A750E Upper VB - Bottom View
(750E & F check-balls shown)
© = 10

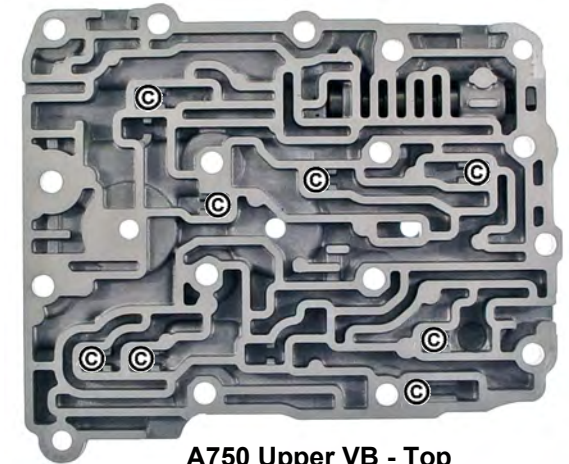
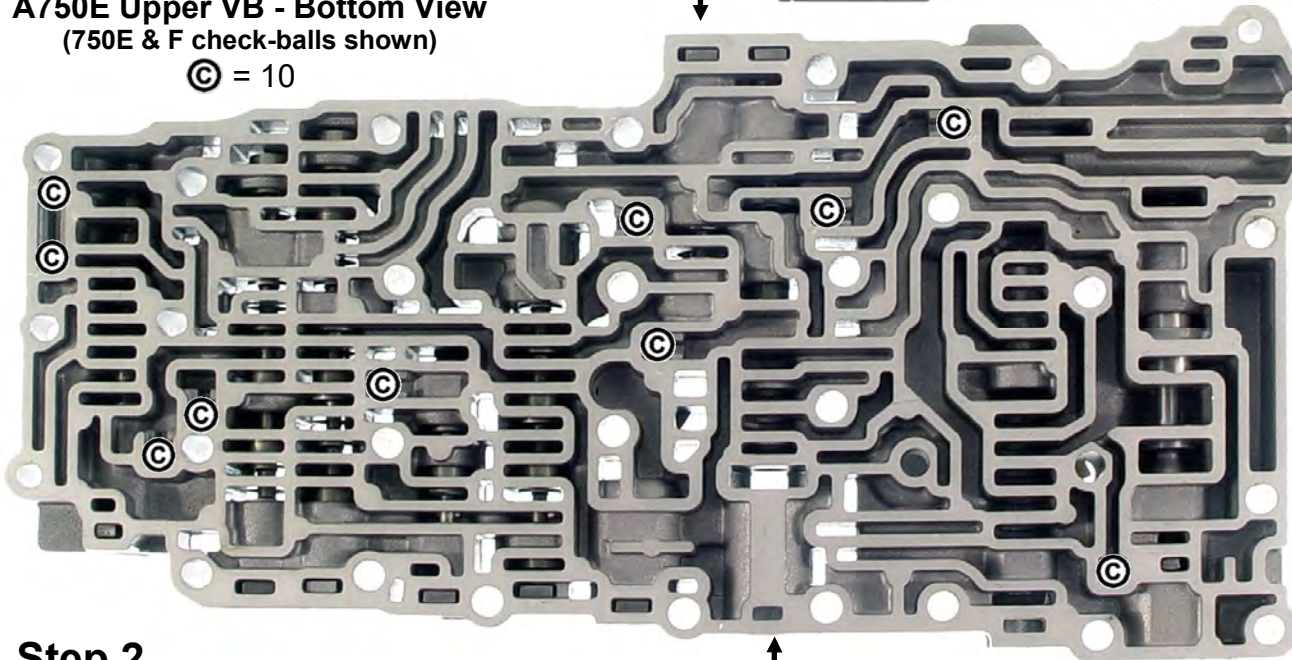

A750 Upper VB - Top
(750 E&F check-balls shown)
© = 8

Step 2

Remove TCC Control Valve & clean. **Match NEW Bushing Diameter** to your original Bushing diameter. Then discard **old** Bushing, Inner Valve & Retainer. Clean & re-install original TCC Control Valve into VB. Install **New** Inner Valve with **original** spring into **New** Bushing and insert into VB as shown. Install **New Shorter Retainer** to prevent VB damage.

ALL Retainers MUST NOT extend up above VB surface when installed!

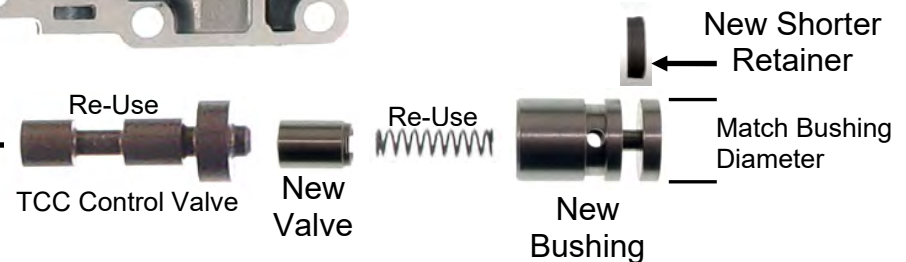

A760, A761 & AB60 VB Section

Warning! Record ALL checkball locations during disassembly. IF ANY CHECKBALL LOCATIONS ARE DIFFERENT from what we show ALWAYS re-install check ball's exactly as you found them!

Reinstall check balls as you found them. Typical models and locations shown.

Shown in this kit are the typical locations. There may be other variations.

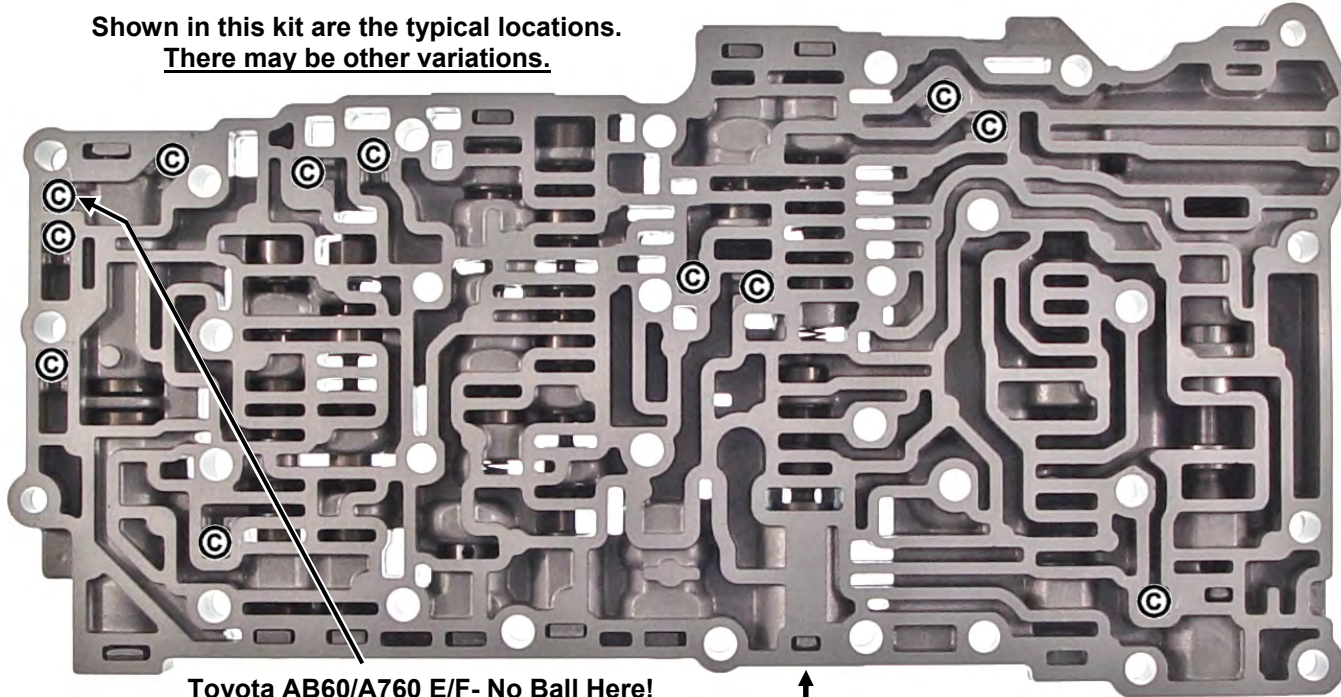

Toyota AB60/A760 E/F- No Ball Here!
Lexus A761E- Install this Ball

A761 Upper VB - Bottom View
Checkballs © = 11 or 12

A761 Upper VB - Top
Checkballs © = 8

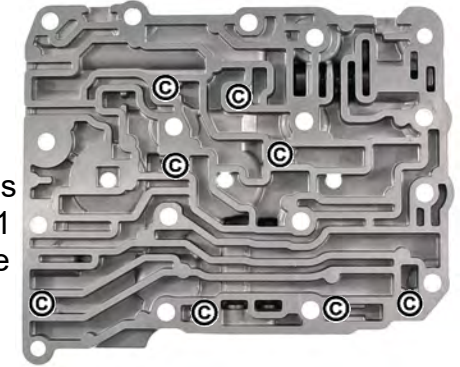

Lexus A761 Type

Toyota AB60 A760 Type

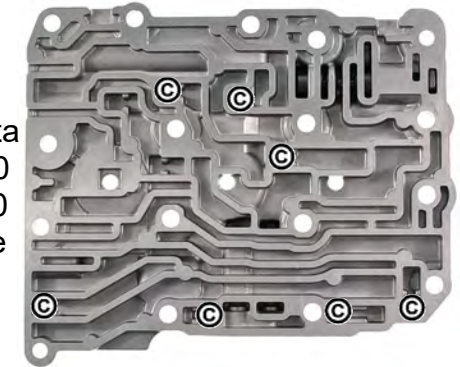

AB60 Upper VB - Top
Checkballs © = 7

Step 1

Remove TCC Control Valve & clean.
Match NEW Bushing Diameter to your original Bushing diameter. Then discard **old** Bushing, Inner Valve & Retainer.
Clean & re-install original TCC Control Valve into VB.
Install **New** Inner Valve with **original** spring into **New** Bushing and insert into VB as shown.
Install **New Shorter Retainer** to **prevent** VB damage.

ALL Retainers **MUST NOT** extend up above VB surface when installed!

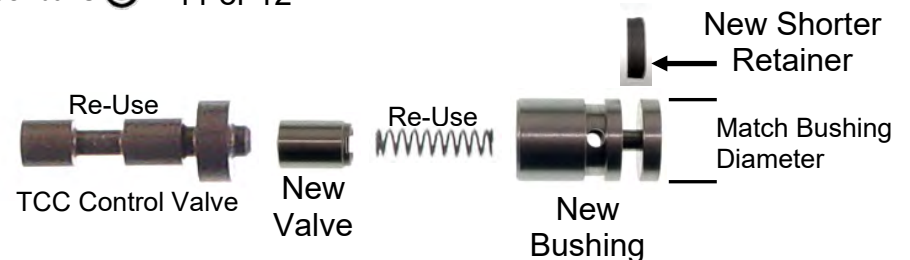

A960 VB Section

Warning! Record ALL checkball locations during disassembly. IF ANY CHECKBALL LOCATIONS ARE DIFFERENT from what we show ALWAYS re-install check ball's exactly as you found them!

A960 Upper VB - Bottom View

Checkballs © = 11

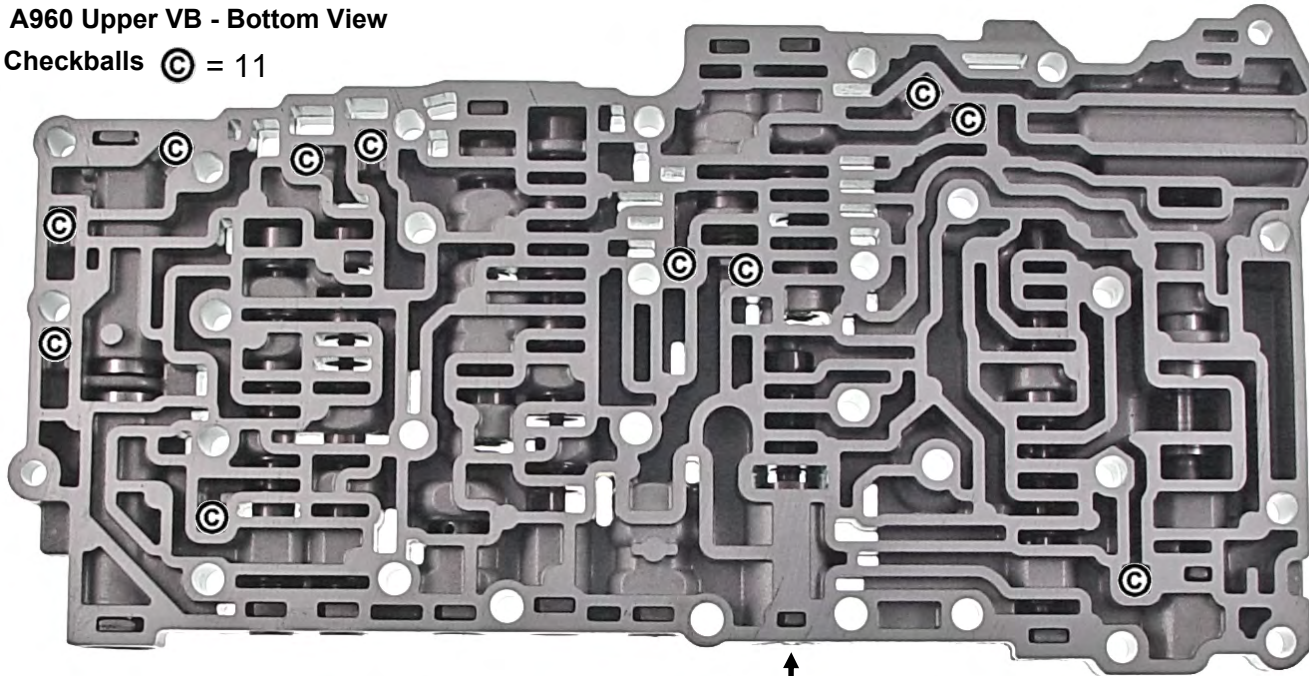

Shown in this kit are the typical locations. There may be other variations.

A960 Upper VB - Top

Checkballs © = 6

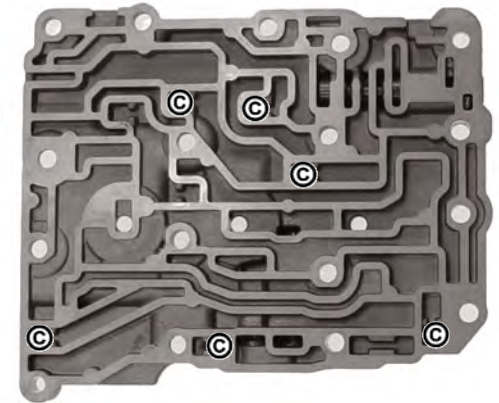

Step 1

Remove TCC Control Valve & clean.

Match NEW Bushing Diameter to your original Bushing diameter. Then discard **old** Bushing, Inner Valve & Retainer.

Clean & re-install original TCC Control Valve into VB. Install **New** Inner Valve with **original** spring into **New** Bushing and insert into VB as shown.

Install **New Shorter Retainer** to **prevent** VB damage.

ALL Retainers **MUST NOT** extend up above VB surface when installed!

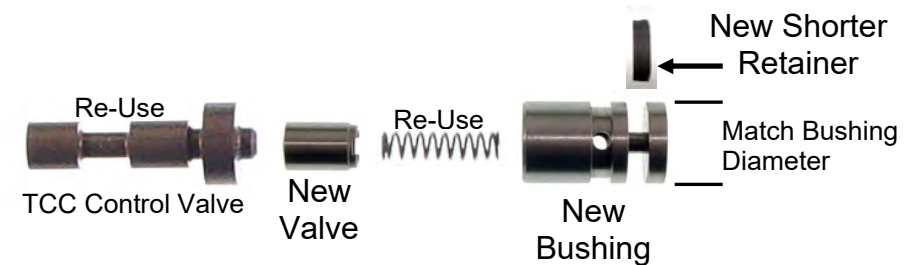

A760, A761, AB60 & A960 Lower Solenoid Body Section

ALL Retainers **MUST NOT** extend up above VB surface when installed!

A960 Lower Solenoid Body



Step 1

Remove & Discard Original Sol Reg Valve, Spring & Plug. Install New Bushing, Valve, Orange Spring & New End Plug. Re-use original retainer.

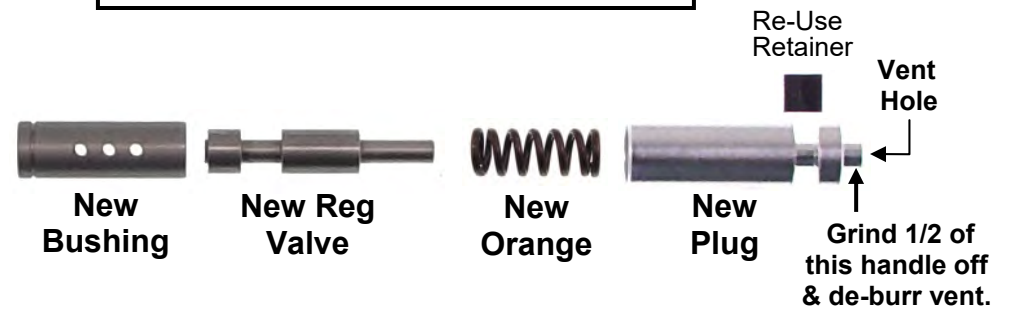
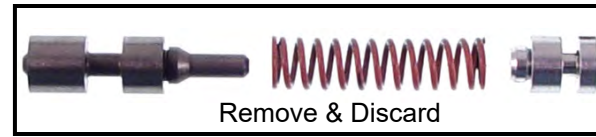

A760, A761 & AB60 Lower Solenoid Body

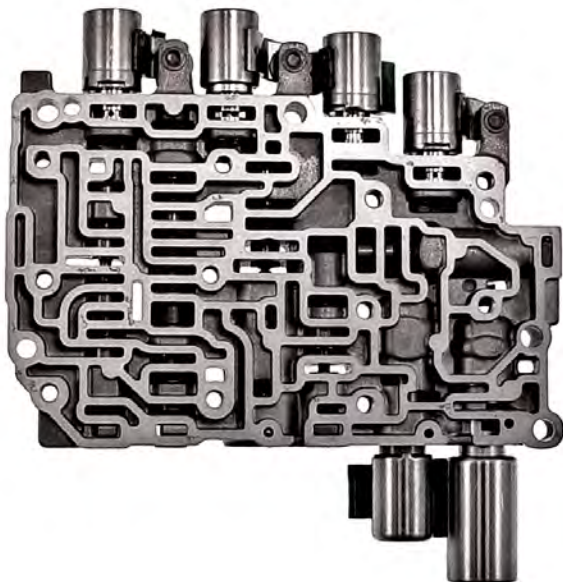

Heads Up! We have had reports that on SOME models the handle of the new plug MAY touch the pan or case. Therefore, on A760, A761 & A960 models grind the handle of the plug down about half way & de-burr vent hole before installing. Make sure the vent hole is open.

NEW PRODUCT AVAILABLE!

Order p/n: **A750-Boost**

Fits: **A750E/F, AB60E/F, A760/761E/H or A960E**

Contains One Replacement Steel Main Pressure Regulator **Boost Bushing and Valve**.

Replaces high mileage/worn out Boost Bushing & Valve that can cause *Lazy* or *Low* pressure rise leading to TCC Slip, Ratio or Performance codes, poor shift quality and or clutch failure.