

Honda-LK2 Lube Correction Kit- Fixes up to 6 Transmissions

Patent Pending



Corrects/Prevents/Reduces:

Repeated Hot Trip Converter Blues.
(Severe Converter Overheating)

Fits The Following Model Transmissions Only:

Acura:

CL 4Cyl: 97-99 A6VA, B6VA
RSX 4Cyl: 02-07 MRMA
TSX 4Cyl: 04-09 MCTA, MM7A

Honda:

Accord V6: 95-97 MPZA
Accord 4 Cyl: 94-12 MPOA, AOYA, BOYA, BAXA, MAXA,
MCLA, BCLA, M91A, B90A.
Odyssey 4 Cyl: 95-98 MPJA, MDWA
CRV: 97-11 M4TA, MDLA, MDMA, MRVA, MCVA,
MKZA, MKYA, GPPA, GPLA, MZHA, MZJA,
BZHA, BZJA.
CIVIC: 96-15 A4RA, B4RA, B46A, M4RA, BDRA,
S4RA, BMXA, SLXA, SPCA.
Element: 03-11 BZNA, BZKA, MZKA, MNZA
Prelude: 97-01 M6HA

Hello Tech!

Four cylinder models don't suffer "Converter Blues" as often as the V6 models **but they can still ruin your day** when they do. Remember, we are addressing the hidden cause of low converter charge which leads to severe overheating of the converter. This kit does not fix slipping shifts, missing gears or electrical codes.

The Reality: Due to the high cost of labor and parts on these units, we felt it was imperative to provide you with the parts and data to keep those lurking "time bomb" jobs from becoming profit killers **AND** do it economically.

We've attempted to cover all the most "common" units as accurately as humanly possible. Please call us if you have any additional information you wish to share.

Thanks for listening and thanks to the many shops who were kind enough to share their precious time and energy in pursuit of a positive direction for all of us.

The Tech Team

Note: We've included in this kit the 95-97 Accord V6 only because it shares the 4 cyl type parts.

Model not listed AND your Converter is Blue? Call Us!
Be near the trans with a caliper and have the car info & trans model at hand. Product Support at (626) 443-7451

This trans is just going to love the care you've given it. Keep up the great work!



Use this page for models: AOYA,
BOYA, MPOA, A6VA, MPJA.

Also Fits *MPZA

*Functionally the same but looks like a
mirrored image. (Flipped Backwards)

Step 1

With a sharp pick, make a dink in this side of partition/wall to keep the drill
bit from walking and drill a .046 hole thru the side of the wall under the X.

When you're finished the .046 hole will
connect cavities 2 & 3 together.

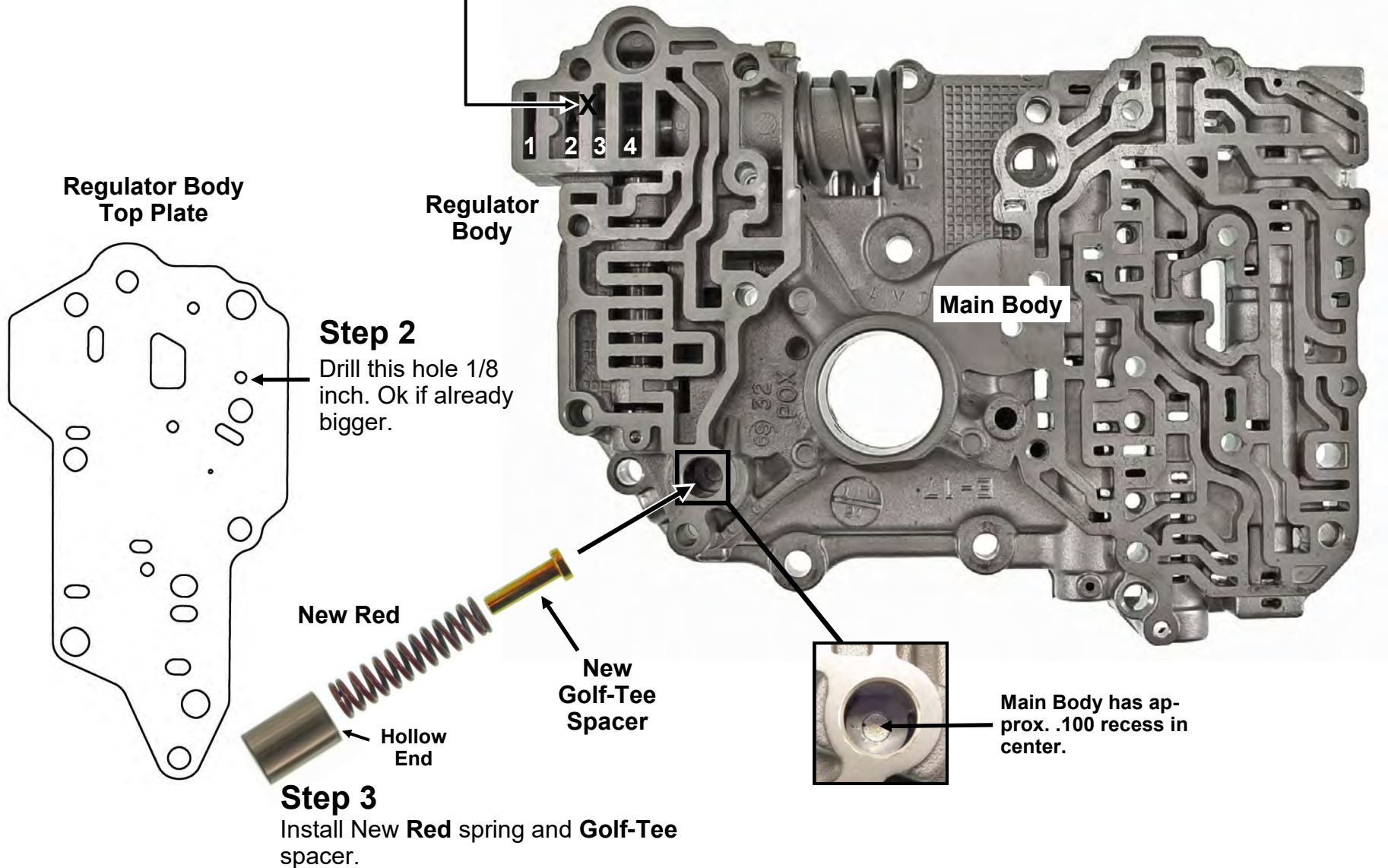

Use this page for models: **BMXA, SLXA, B4RA, B46A, M4RA, BDRA, S4RA, A4RA, MDLA, MDMA, M4TA.**

Step 1

With a sharp pick, make a dink in this side of partition/wall to keep the drill bit from walking and drill a .046 hole thru the side of the wall under the X.

When you're finished the .046 hole will connect cavities 2 & 3 together.

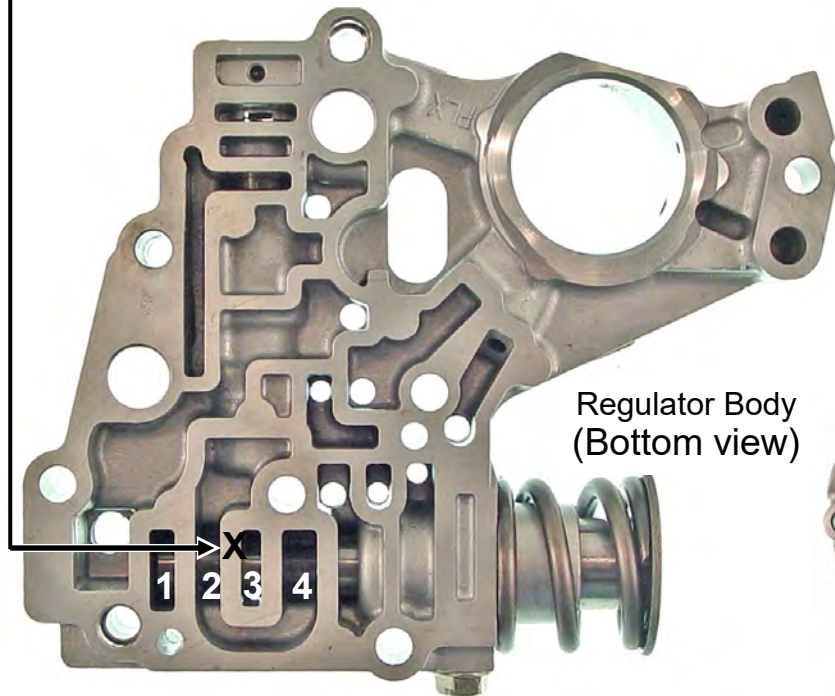

Regulator Body (Bottom view)

Regulator Body (Top view)

Regulator Body Top Plate

Step 2

Drill this hole .156 inch. Ok if already bigger. De-burr the hole after drilling.

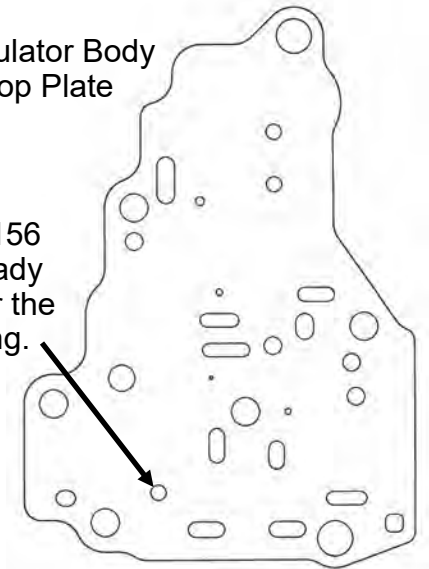

Step 3

Install New **Black** spring and 2 Groove spacer.

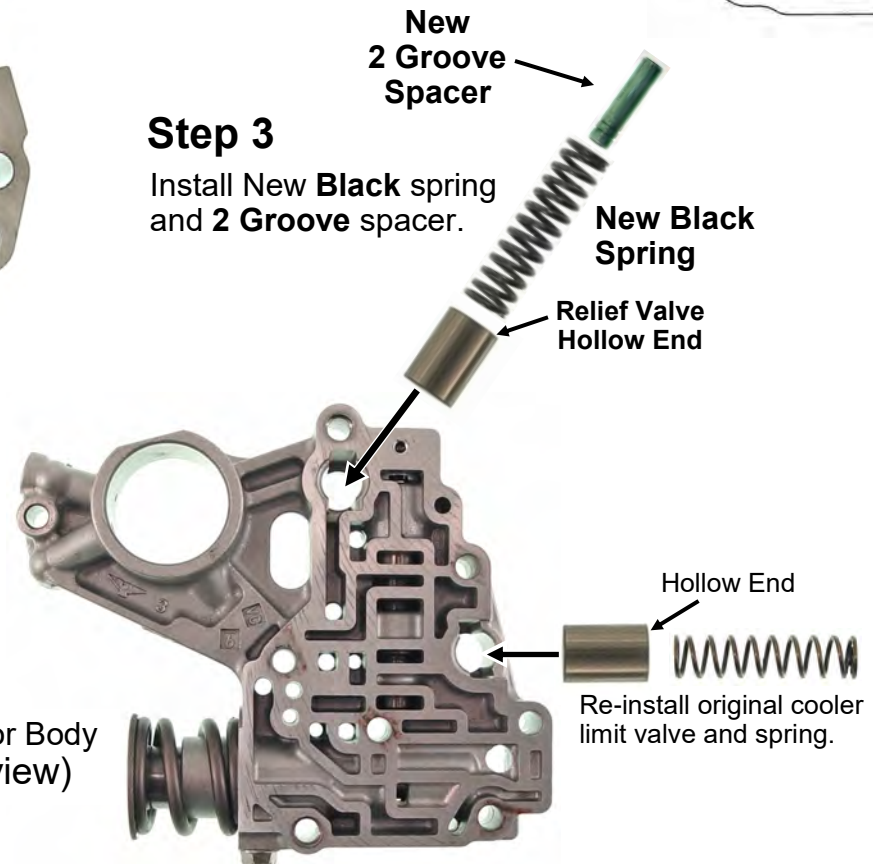

Use this page for models: MCLA, BCLA, M91A, B90A, MKZA, MKYA, GPPA, GPLA, MZHA, MZJA, BZNA, BZKA, MZKA, MNZA BZHA, BZJA, SPCA, MRVA, MCVA, MCTA, MRMA, MM7A.

Step 1

Remove and discard original spring. Install **New Yellow Spring** and original retainer. **Note:** This type body does not use an added spacer inside the relief spring.

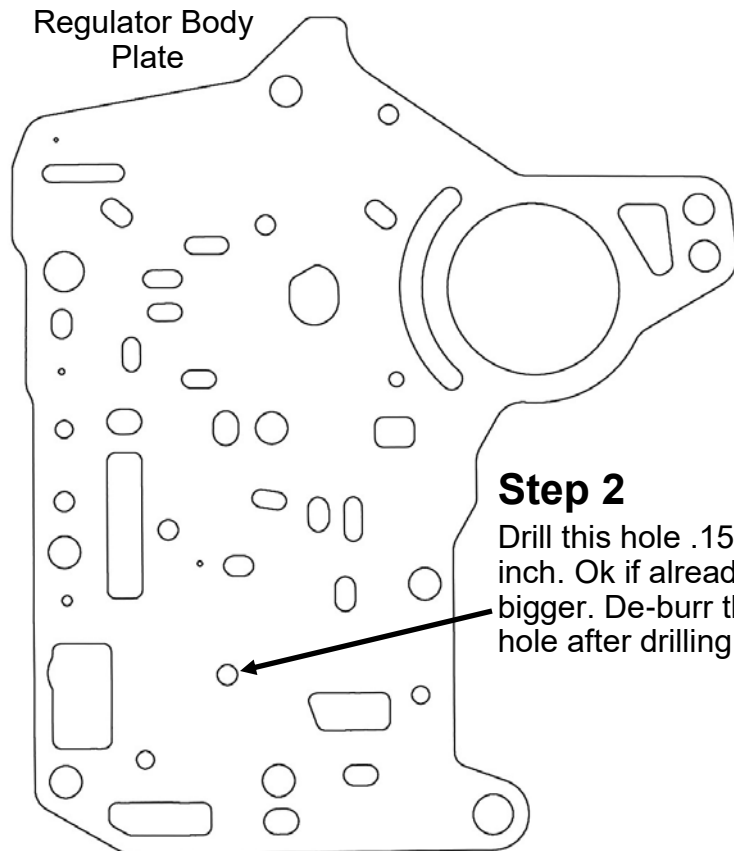

Step 2

Drill this hole .156 inch. Ok if already bigger. De-burr the hole after drilling.

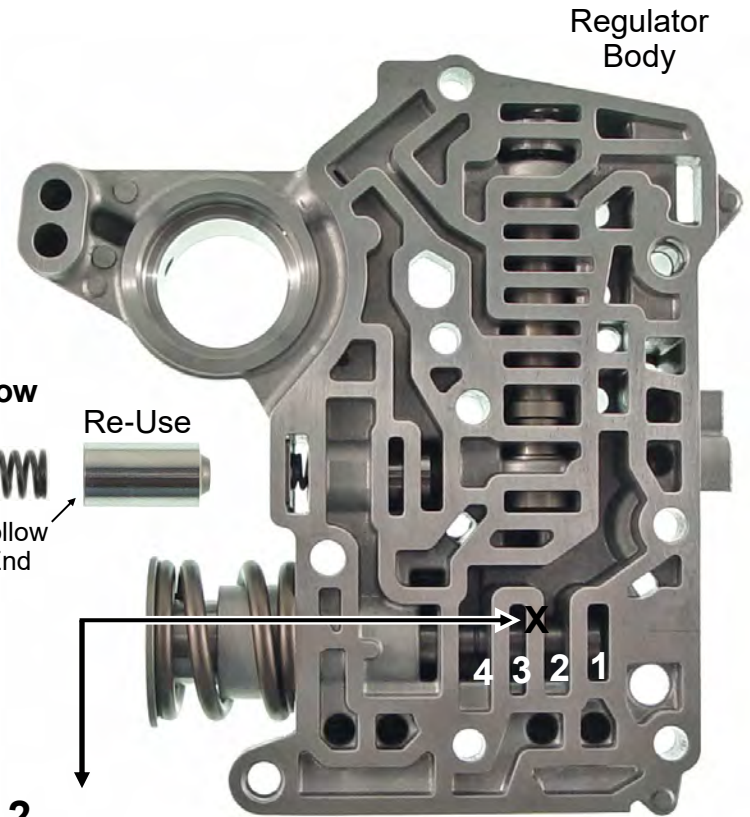
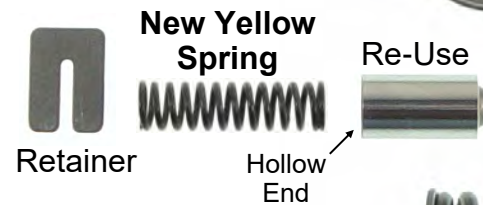

Step 2

With a sharp pick, make a dink in this side of partition / wall to keep the drill bit from walking and drill a .046 hole thru the side of the wall under the X.

When you're finished the .046 hole will connect cavities 2 & 3 together.

Use this page for models: MDWA, BAXA, MAXA, B6VA, M6HA.

Step 1

With a sharp pick, make a dink in this side of partition / wall to keep the drill bit from walking and drill a .046 hole thru the side of the wall under the X.

When you're finished the .046 hole will connect cavities 2 & 3 together.

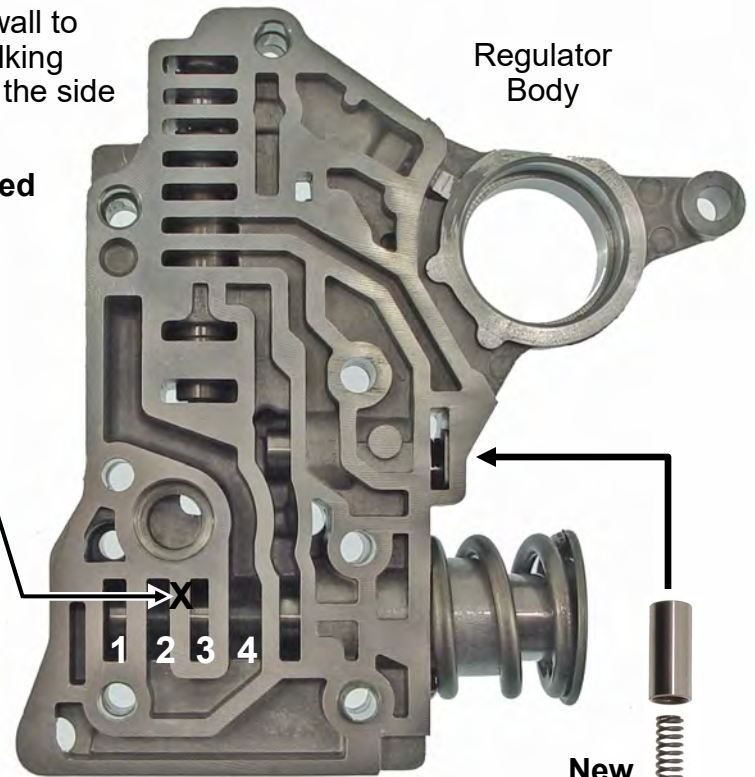

Regulator Body

Step 3

Drill this hole .156 inch. Ok if already bigger. De-burr the hole after drilling.

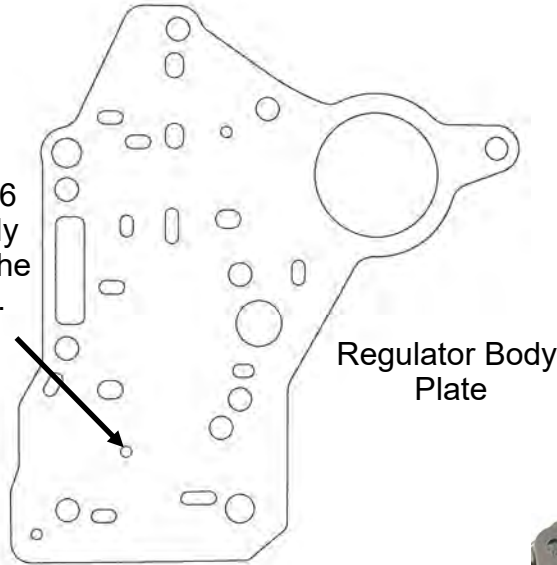

Regulator Body Plate

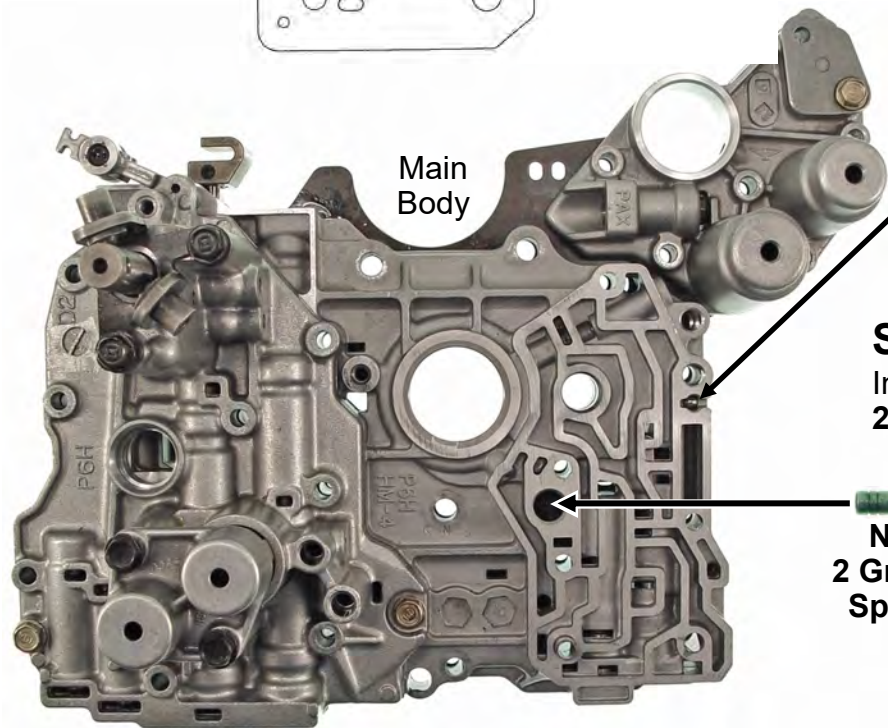

Main Body

Step 4

Install New **Black** spring and 2 Groove spacer for Relief Valve.

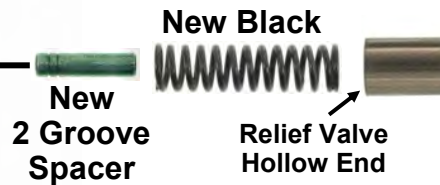

New 2 Groove Spacer

New Black Spring
Relief Valve Hollow End

Step 2

Remove & discard original Spring. Install New **White** Spring and re-use retainer.



New White Spring

We are delighted to provide you with useful tech and products that help you be more successful. We wish you all the best!

The Tech Team

Keep both the **Honda LK (V6's)** & the **Honda LK2 (4 cyl's)** in stock and you'll cover the most popular models from Honda and Acura!

Honda-LK2 Patent Pending For most 4 cyl units

Lube Correction Kit
Fixes up to 6 Transmissions

Corrects/Prevents/Reduces:

Repeated Hot Trip Converter Blues.
(Severe Converter Overheating)

Fits The Following Model Transmissions Only:

Acura:

CL 4Cyl: 97-99 A6VA, B6VA
RSX 4Cyl: 02-07 MRMA
TSX 4Cyl: 04-09 MCTA, MM7A

Honda:

Accord V6: 95-97 MPZA
Accord 4 Cyl: 94-12 MPOA, AOYA, BOYA, BAXA, MAXA,
MCLA, BCLA, M91A, B90A.
Odyssey 4 Cyl: 95-98 MPJA, MDWA
CRV: 97-11 M4TA, MDLA, MDMA, MRVA, MCVA,
MKZA, MKYA, GPPA, GPLA, MZHA, MZJA,
BZHA, BZJA.
CIVIC: 96-15 A4RA, B4RA, B46A, M4RA, BDRA,
S4RA, BMXA, SLXA, SPCA.
Element: 03-11 BZNA, BZKA, MZKA, MNZA
Prelude: 97-01 M6HA

Honda-LK Patent Pending For most V6 units

Lube Correction Kit
Fixes up to 6 Transmissions

Corrects/Prevents/Reduces:

Repeated Hot Trip Converter Blues.
(Severe Converter Overheating)

Fits The Following Model Transmissions Only:

Acura:

CL V6 Only: 97-03 M7ZA, BGFA, MGFA
3.2TL & TL: 99-09 B7VA, M7WA, B7WA, BDGA, BDHA
MDX: 01-09 MGHA, BGHA, MDKA, BDKA, BYFA
RL: 05-08 MJBA

Honda:

Accord V6 Only: 98-09 B7XA, BAYA, MAYA, B97A
Odyssey V6 Only: 99-09 B7TA, B7YA, BYBA, BGRA,
PGRA, P36A, B36A
Pilot: 03-09 BVGA, PVLA, PVGA, P35A, P34A
Ridgeline: 06-14 BJFA, MJFA, PSFA
Saturn:
Vue: 04-08 MDRA, MDPA