



Patent # 11,408,447

# SK<sup>®</sup> 5R110W-A

2003 Up

## Reduces/Corrects/Prevents

Case Lug Blow Out--Runaway Reverse Pressure  
No movement--Slips or No Reverse--Neutrals at a Stop  
*Contains New (Patent Pending) 2 piece Design PR Valve  
(fits standard PR bores)*

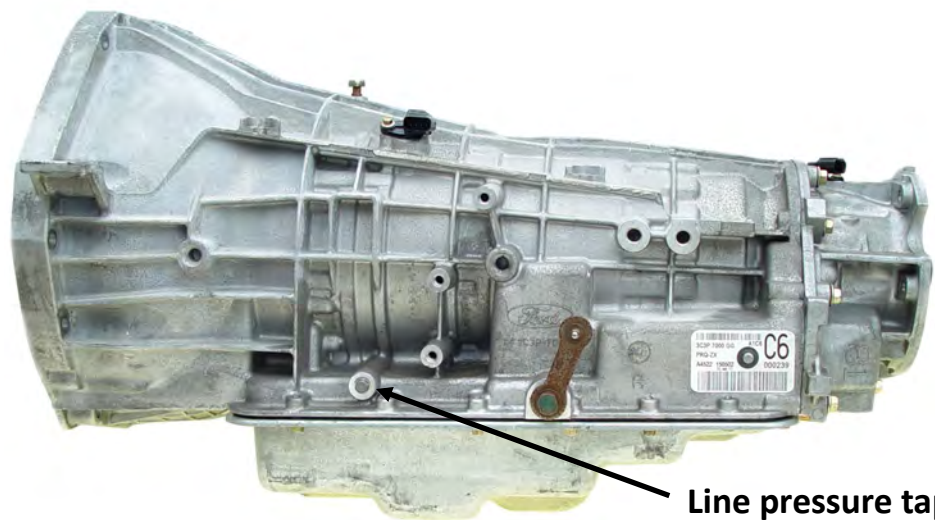

Line pressure tap

Very common for this trans to have a high line pressure error, up around 450 lbs, especially in reverse with throttle ON. Sooner or later this *will* blow off Low Reverse snap ring lugs, destroying the case. **OUCH!** 😞  
The Shift Kit<sup>®</sup> has upgrades that brings pressure to safe specs, plus a tougher L/R snap ring.

“Thanks for listening.” Gil

Before installing upgrades checking pressures will require a 600 lb gauge. TransGo has them: \$38.00



## Oil Pressure Checks

Pressure readings AFTER Kit installation. A real winner! 😊

Selector	Min psi	Max
Park	60	NA
Neutral	60	NA
Reverse	100	320
Drive	70	260
3	80	260
2	80	260
1	80	260

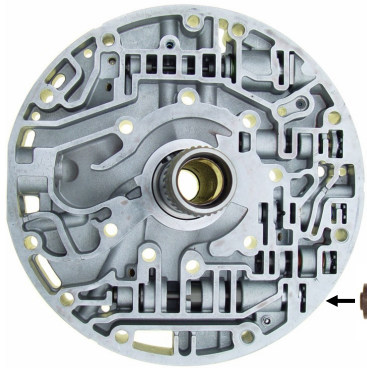

### Step 1

Remove original Pressure Regulator lineup.  
 Measure the diameter of end bushing.  
 If it measures .728" (original size), proceed to Step 2 below. If it measures .768 it has been reamed oversize. Skip the rest of this page and proceed to page 3.

### New Patented 2 Piece PR Valve:

This valve was designed to work in a worn & distorted bore to reduce or prevent sticking. This design incorporates features to maximize long term function and will not vacuum test well as a result. It's OK! REALLY! Just make sure its free in the bore on installation and move on.

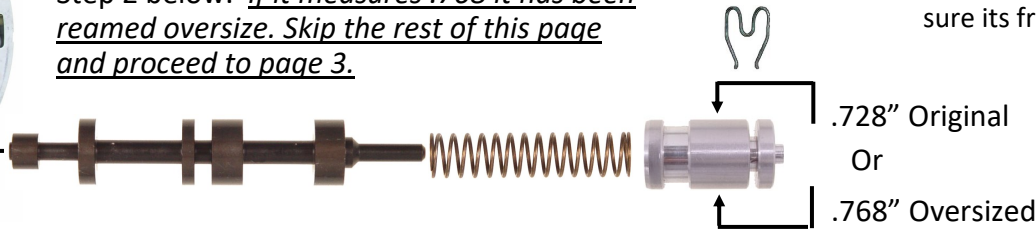

Assemble New PC Limit Bushing that measures .728"



New .728" bushing  
 Has No ID Groove here.

Ball  
 .187"

Orange  
 Spring

Cotter Pin



### Step 2.

Assemble New .728" Diameter PC Limit Bushing: Insert .187 ball into bushing first, then insert and compress Orange Spring with the small end of the paper clip. Install cotter pin into bushing thru holes and spread legs of cotter pin. **Remove** paper clip with pliers.

### Step 3.

**New Steel 2 piece PR Valve Installation Check:** (Used with .728" size PC Limit Bushing only.)  
 Insert both **New Steel** PR Valves into the bore and check for smooth movement. Any ridge or burr that creates a tight spot **MUST** be flattened to prevent sticking. Here's how: **Move valve onto the tight spot.** Use a 11/16 open end wrench as a hammer and flat blade screwdriver on the valve, tap the screwdriver in the areas between the polished lands to loosen the tight spot. Re-check for smooth movement. **Do NOT tap on the polished Lands of the valve!** Assemble as shown below.

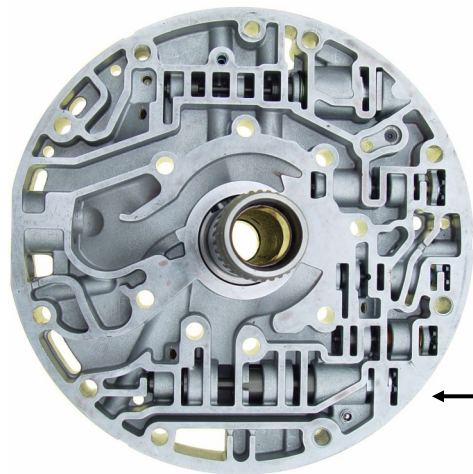

**New Steel PR Valve** replaces factory grooved or non-grooved PR Valves. Do not use in oversize bores.



New Plain

Retainer

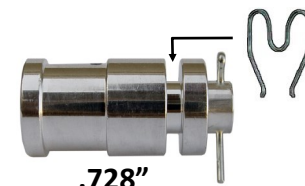

.728"  
 PC Limit  
 Bushing

Only use this page with .768" oversized PR Lineup.

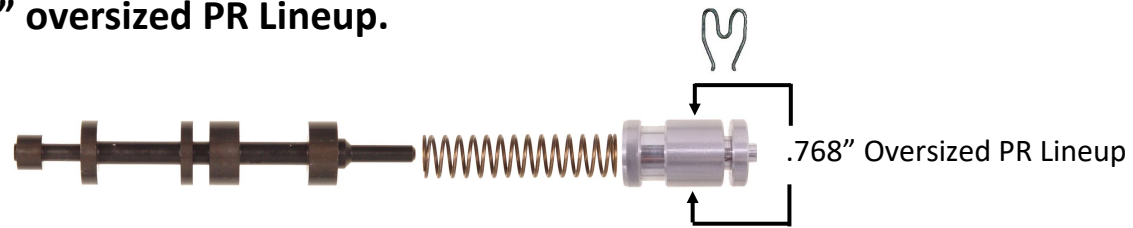

Assemble New PC Limit Bushing that measures .768"



Ball .187"



Cotter Pin



### Step 1

Assemble the New .768" Diameter PC Limit Bushing: Insert .187" ball into bushing first, then insert and compress Orange Spring with the small end of the paper clip. Install cotter pin into bushing thru holes and spread legs of cotter pin. **Remove** paper clip with pliers.

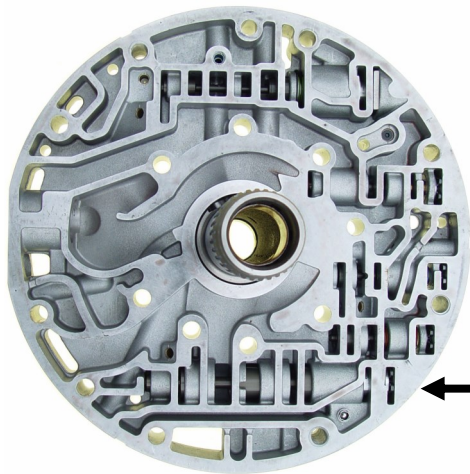

### Step 2

Re-Use **Original** PR Valve & Spring the Pump came in with. Install New Assembled .768" PC Limit Bushing & New Retainer.

Re-Use Original Oversized PR Valve



Re-Use Original

.768

Retainer



Oversize PC Limit Bushing

Do not Tap on or use Sandpaper on Aluminum Valves!  
If oversized PR is sticking or dragging **REPLACE** Pump!

# Listen Up! Save yourself from a major headache – Please Read:

Installing Retainer in the **outer passage** of pump and **outer groove** on the bushing- **IS OK! REALLY! It's OK!**  
 Installing Retainer in the **2nd passage** of pump and **2nd groove** on bushing- **IS OK!** (Factory Location)  
 Just make sure its assembled in **either one** of these 2 ways. Any **OTHER** way is **NO LOCKUP!**  
 Newest Pumps from Ford can only be assembled **one** way!

**Do Not Mix Pump Halves!**  
**See Additional Data Provided.**

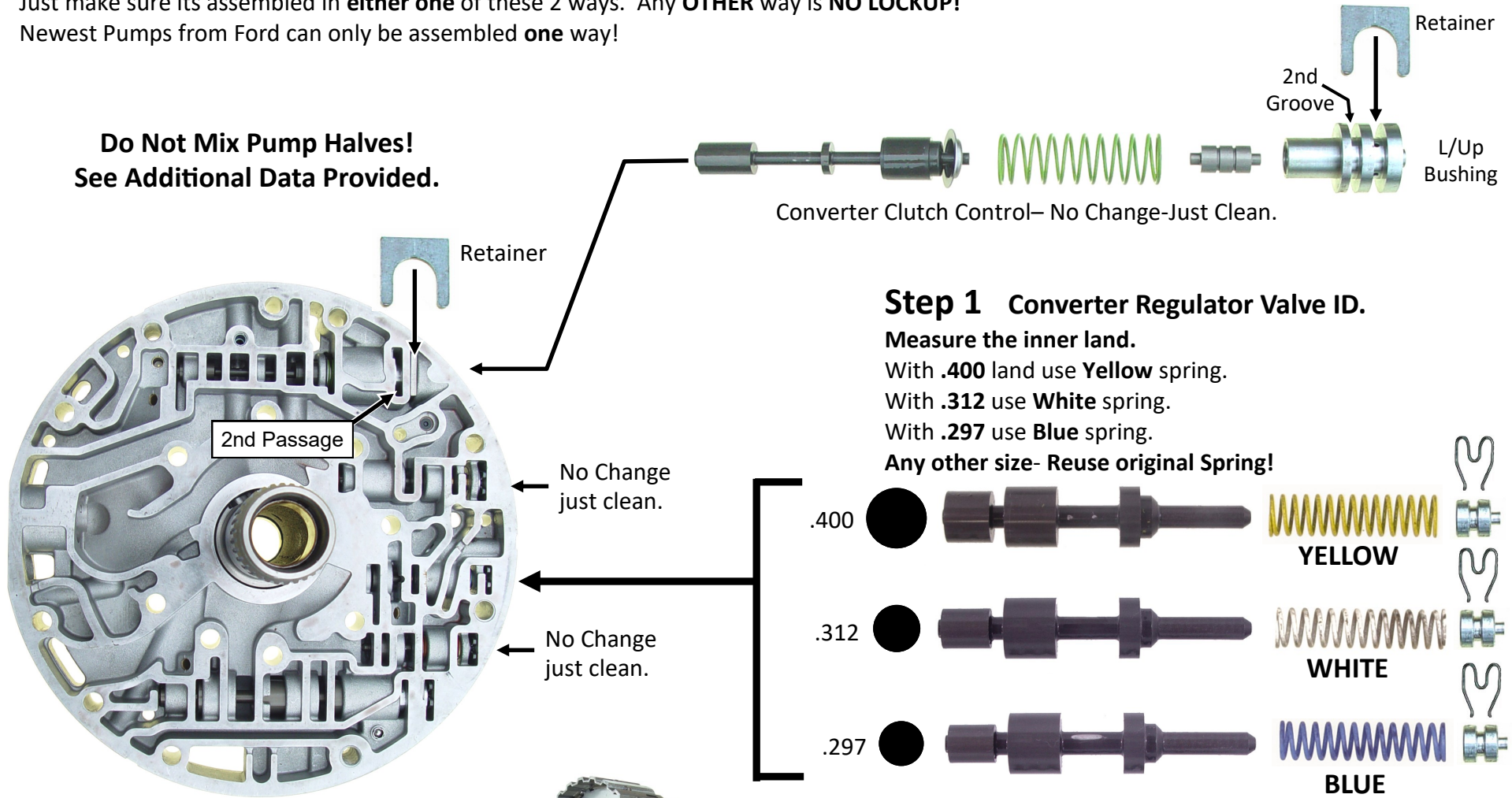

**Tip: Direct Drum bushings may look good but are worn out! Change them!**  
 (Drum rocks on support with worn out bushings!)



## Case Lug & Low Reverse Snap Ring Blow Out:

If the trans came in with no Reverse or Slip in Reverse, this is the first thing to look at to see if you will need a new case.

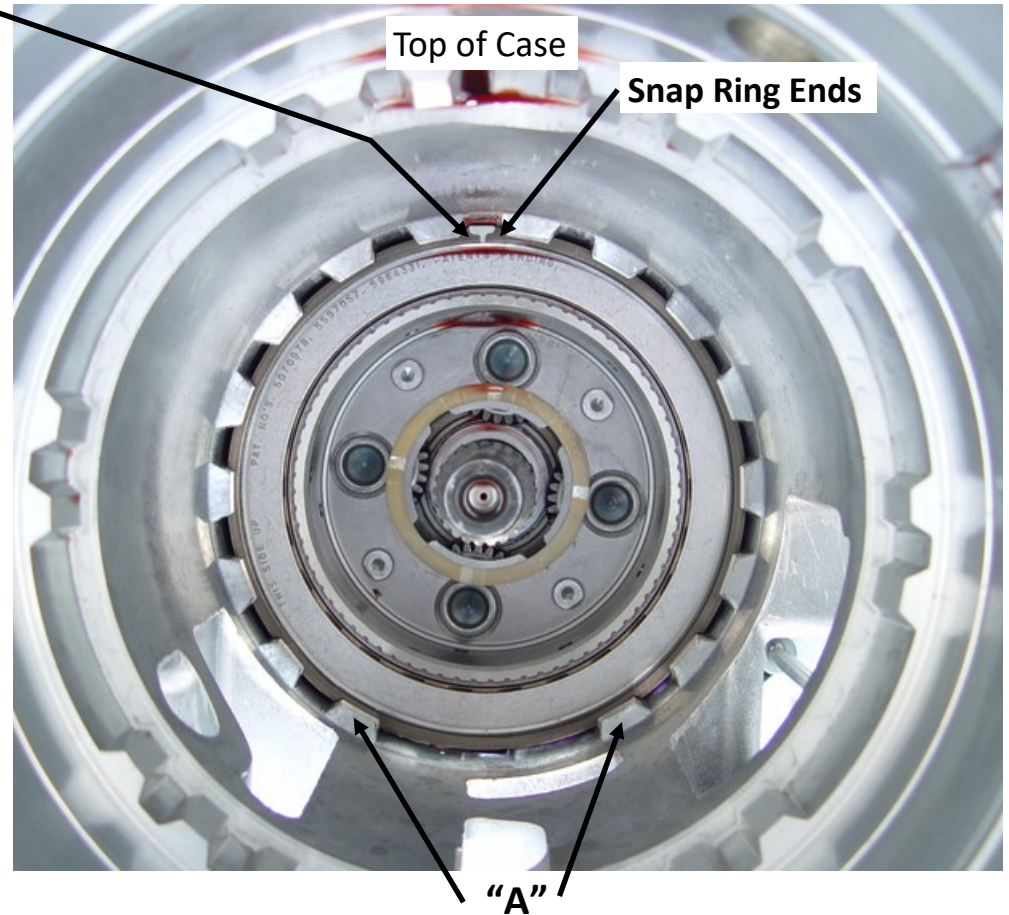
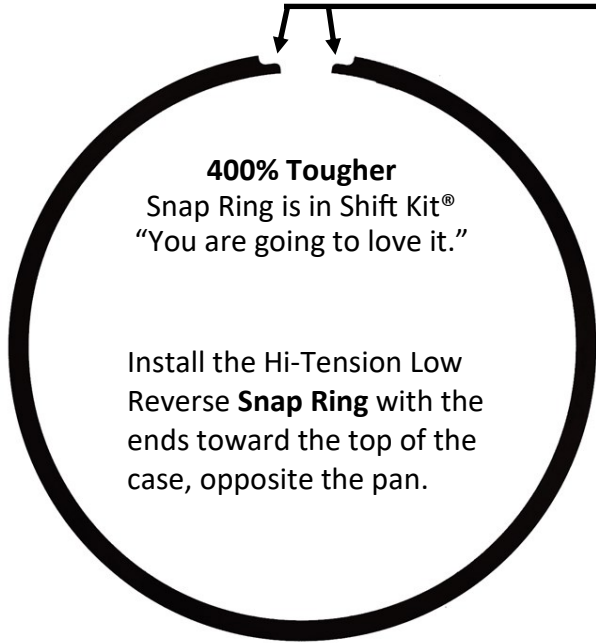

This is where the snap ring normally rubs on the planetary.

### WARNING!

Do NOT remove the **INNER** Snap ring in the outer race of the ratchet. If you do, the outer race will drop & the ratchet will disassemble! You'll now be buying a new assembly. The low/rev clutches are serviced as part of this new style assembly.

**"A"**: These are the two lugs that break off. If they're broken off, a new case is needed. If they are angle worn but still there, the tougher snap ring will save the case.

New Style 1 Piece Low Ratchet & Clutch Assy!  
**DO NOT DISASSEMBLE!!!**  
**DO NOT REMOVE INNER SNAP-RING!**

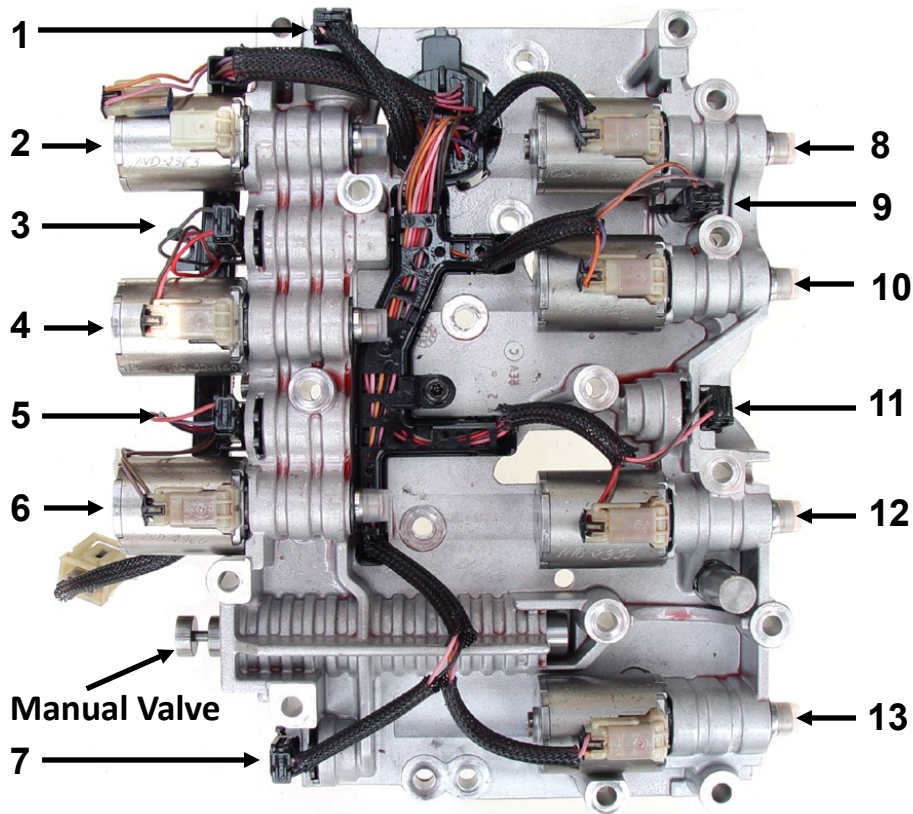

## Solenoids & Switches

\*Pressure switches not used on all models  
If broken replace with alum plug. (1 provided.)

1. Intermediate clutch pressure switch PS-C\*
2. Intermediate clutch SSPC-C
3. Direct clutch pressure switch PS-D\*
4. Direct clutch SSPC-D
5. Low/reverse clutch pressure switch PS-E\*
6. Low/reverse clutch SSPC-E
7. Coast clutch pressure switch PS-A\*
8. Line pressure control PC-A
9. TFT Fluid temp
10. TCC Torque converter clutch
11. Overdrive pressure switch PS-B\*
12. Overdrive clutch SSPC-B
13. Coast clutch SSPC-A

Early valve bodies contained (5) Pressure Switches that were never used nor monitored by the computer. In later valve bodies the holes and the switches were removed with the exception of the Direct Clutch, which retained the hole with a plastic dummy plug installed. It is common during the extreme pressure that breaks the low reverse lugs out of the case to also damage the switches or a dummy plug, particularly the direct clutch dummy plug. Carefully inspect them to avoid a problem.

**One new aluminum plug and O-ring are provided** in case you need it and will replace either a switch or a dummy plug. Wire tie the loose wire connector to the harness if replacing a pressure switch. It is very important to make sure the clip grabs the plug snugly to prevent blowout. Always squeeze the clip ends enough to provide a good grab on the plug.

Additional plugs are available separately thru your supplier.  
**TransGo Part # 5R1-PLUG-PS.** Contains 5 new plugs and O-rings.

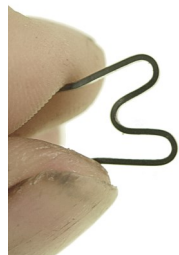

**Squeeze ends of retainer to provide a snug fit on the plug!**



**New Pressure Switch Plug with o-ring installed.**

# Pump Data

## 03-04 Pump Type

Pump half's & wear plate **must** match. **2003-04 Type** Pump Body w/casting code 3C3P and Stator RF3C3P match a plate with two slots inside circle.

Casting # RF3C3P



Two slots here for 03/04 Type

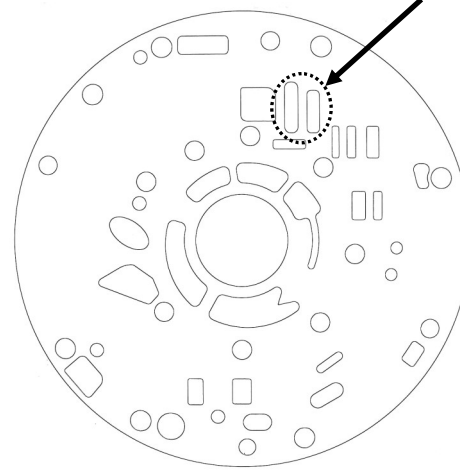

Casting # 3C3P



No Movement **after** repair can be **mismatch** of pump half's **or** wear plate. Pump was redesigned in **2005**. **Complete pumps** can be swapped for all years but mixing parts between pumps can create a no move condition.

## 2005 & Up Type

Pump half's & wear plate **must** match. **2005 Type** Pump Body **and** Stator w/casting code RF5C3P match a plate with no slots inside circle.

Casting # RF5C3P



No slots here-- 2005-09

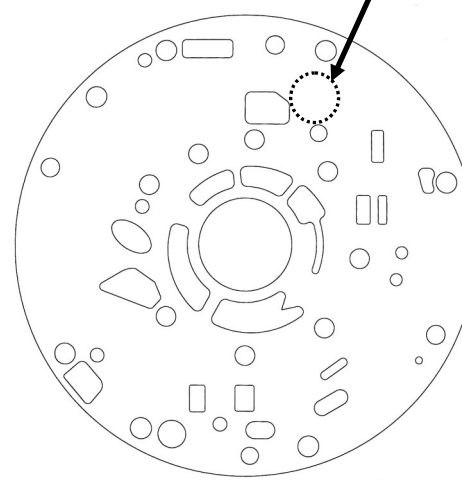

Casting # RF5C3P



***New Products Available NOW!***



*Tools and Instructions for perfect pump alignment!*

**5R1-PMP-ALIGN**

**Fits: 5R110W 2003up**

**Corrects/Prevents/Reduces**  
Severe Damage from Misaligned Pump

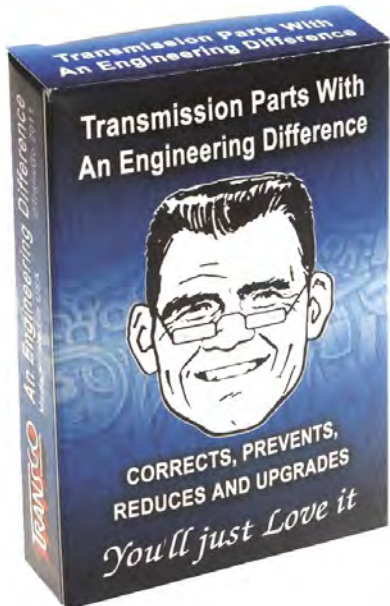

*Stops fluid leaking from out the vent, not caused by overfill or overheating.*



**5R110W Vent**

**Fits: 5R110W 2003up**

**Corrects/Prevents/Reduces**  
Accidental Venting of Fluid



## 5R110 Additional Information

Take heed and give this information some serious consideration. There are more than a few ways to hurt, warp, weld or split the inner gear and generally bring the pump to an untimely death. This information will save the pump, your pocket book and your reputation!

### Cause of Failure: Electrical, Bushing, Oil Starved or Programming?

Knowing how to tell the difference is half the battle.

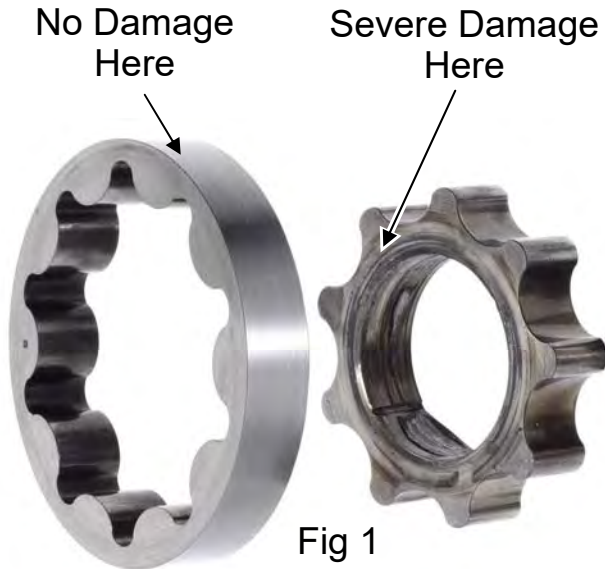

Electrical ground failure or a tight pump bushing clearance will weld the inner gear to the pump plate.



Lack of oil, restricted filter, dry start-up or aggressive TCM programming. Both gears are equally black & blued.

**Pump Bushing To Hub Clearance: If the pump bushing or the converter is changed the bushing to hub clearance must be checked.** Place the feeler gauge through the pump bushing bore then drop the pump body over the converter hub.

**Clearance, min .0025" max .0045".**



We have heard the reports of replacement bushings that will only provide .001" clearance to a properly sized hub. Running the bushing this tight will seize the bushing to the hub and spin the bushing in the pump body. The metal generated will get between the inner gear and pump plate welding them together, this will look like a ground failure, see fig 1. Tolerances and alignment are critical with this pump. See TransGo 5R1-PMP-Align.

**Pump Bushing: Reuse the OE bushing when possible.**

**Some 5R110 pumps have been found with an offset bushing bore. This required the factory to machine the bushing in place, another reason to leave the OE bushing alone. Always use a pump alignment tool that centers the bushing bore to the stator tube. See: TransGo 5R1-PMP-ALIGN.**

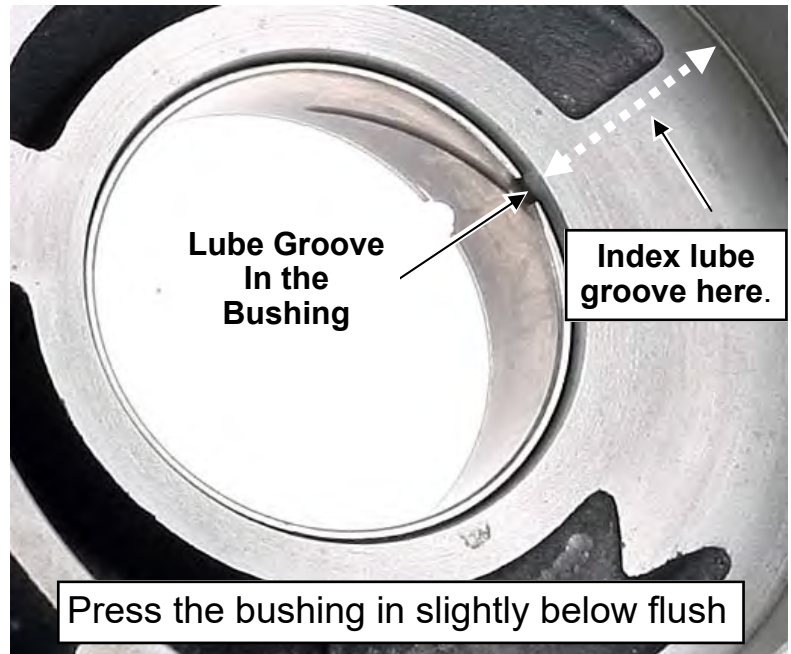

## Changing Converter, Pumps, Gears or Bushings?

**Perform quick test:** With the pump bushing and gears installed into the pump body, place the pump body onto the converter hub so the inner gear indexes to the hub.

Now rotate the body 360 degrees and feel for tight spots or binding. It should rotate smooth as glass all the way around. Binding or tight spots indicates a problem with the gear pocket, gears, convertor hub or pump bushing.



**Line Pressure and Pump Failure:** Aggressive computer programming can contribute to high line pressure and pump failure, see page 1 fig 2. Check with a pressure gauge during the road test. Stock Programming: Light-load cruising speed 150-170psi and very reactive to engine load. Hard throttle up-shifts 200-235psi. Full throttle starts can briefly spike to 280psi.

Constant high line pressure accelerates the wear on the inner pump gear, a little wear is ok. Check the inner gear fit on your converter hub. No binding or excessive rocking is acceptable.

There is no FIX that is going to save the pump when the PCM programming is **commanding 300psi** in the forward gears. Excessive stall time at the drag strip is also a pump killer. Listen to your customer and know when to pass on a job if it's going to eat your lunch.

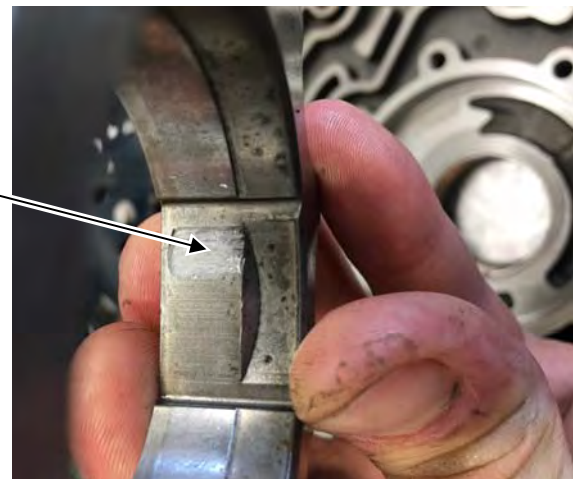

## Pump Gear ID Marks and Outer Gear Chamfer.

The **Original Equipment** pump gears have ID marks on the inner and outer gear. These ID marks **MUST be visible** when the gears are installed into the pump body. With original equipment gears this will ensure that the chamfered side of the outer gear is facing into the pump body. **Attention: If the outer gear ID mark is not visible when installed, the pump will seize on the road test or shortly after.**

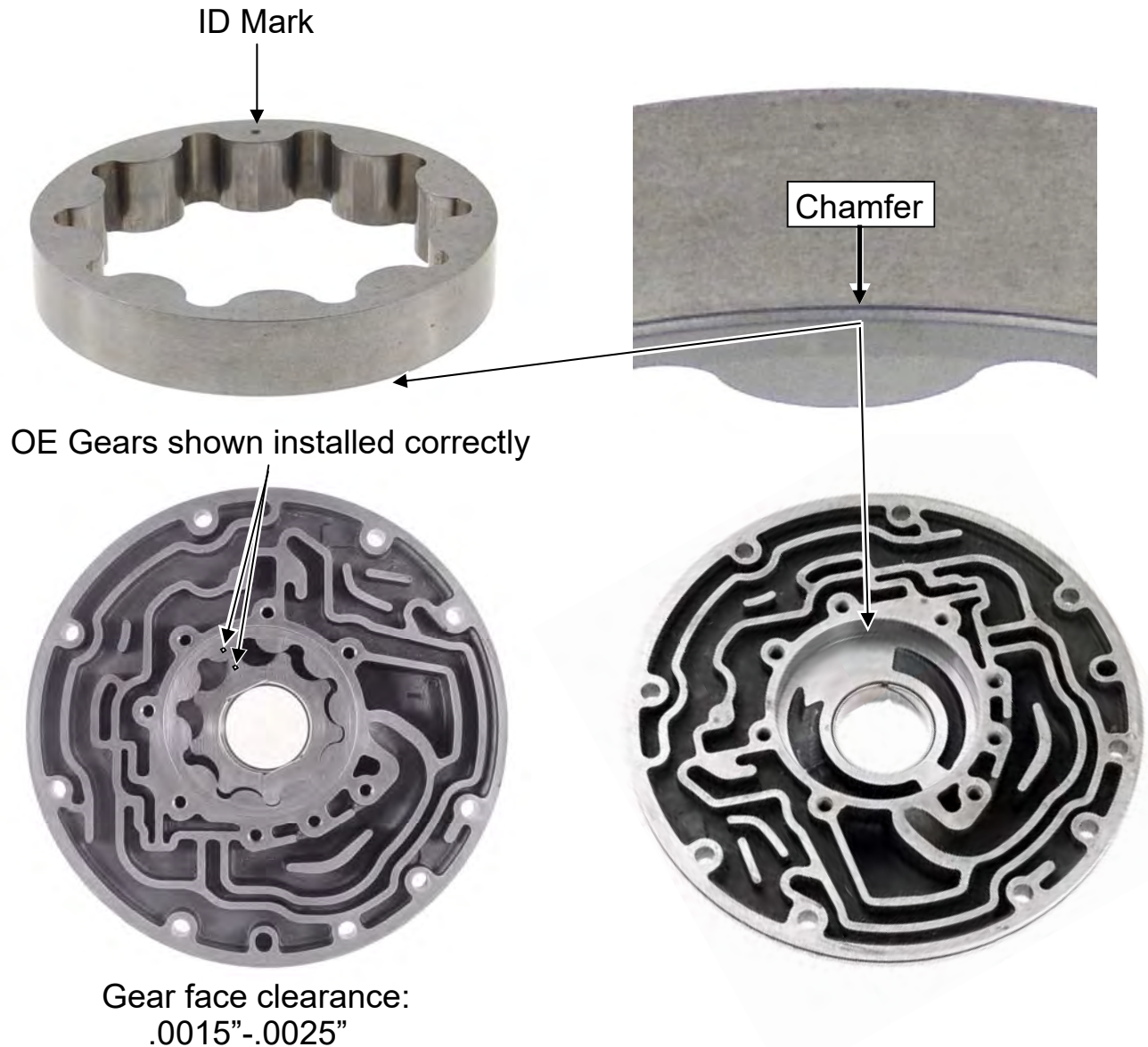

**Never Install Pump Gears Dry.** The gear pocket & both gears should be thoroughly lubed "with ATF only" during assembly. Also, please take the time to pour 3 to 4 quarts of ATF into the converter before installing it. This can be difficult and time consuming however we feel it is necessary.

# Ground Issues:

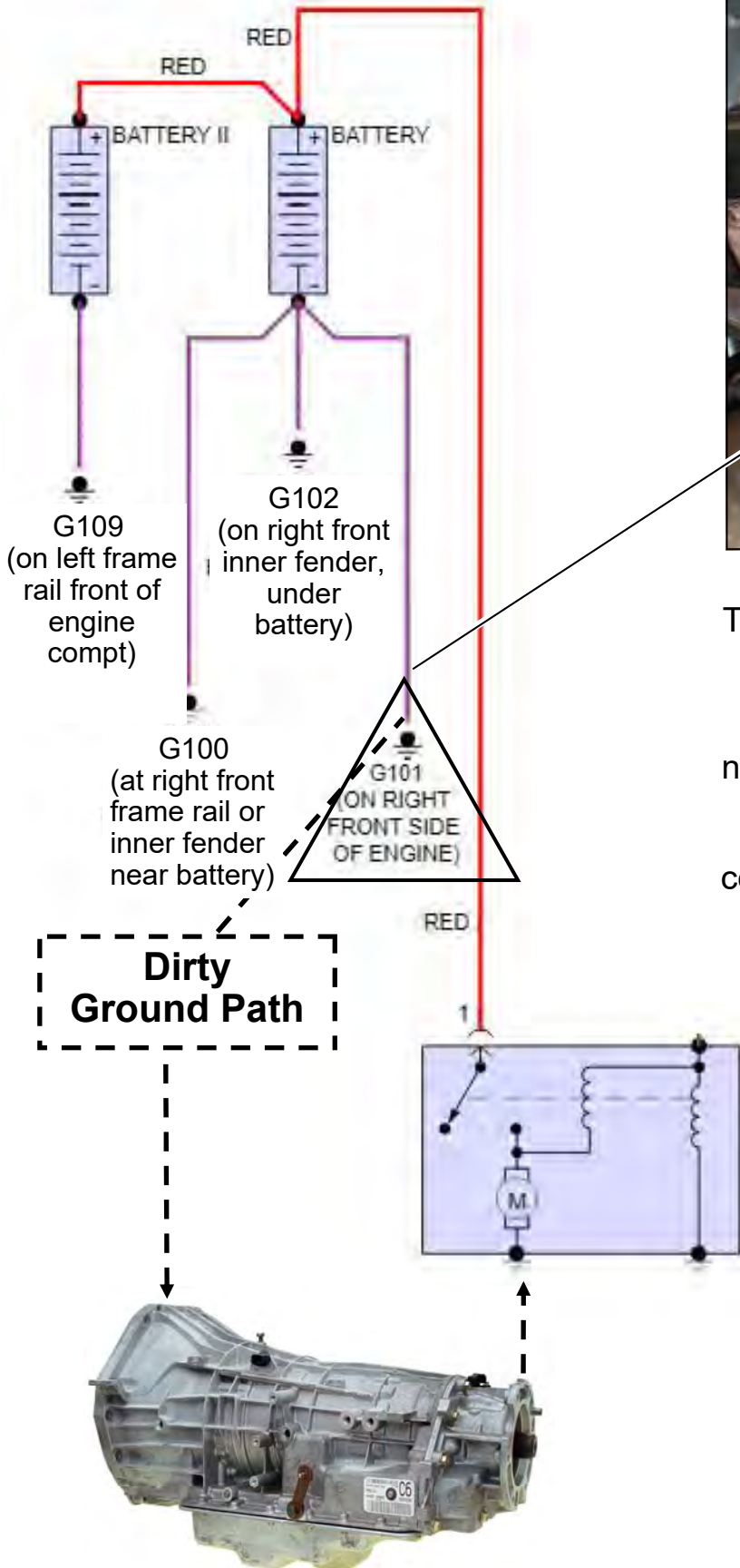

**Oil Pan**

## Diesel Engine

This is the main battery ground on the passenger side front of the engine, #G101. This connection is the most critical one. To clean it correctly, the nut, cable and the stud that screws into the block **MUST** be removed and cleaned, **NO** exceptions. If this connection is dirty the current will take an alternate path through the transmission and damage the pump.

## Ground Issues Cont:

Although these pictures are of a gas rig, diesels show up more with this issue. Often when removing the cab to replace the head gaskets the aux ground straps occur damage. They are hidden behind the motor. You **MUST** fix them if they are damaged or missing otherwise the current will find an alternate path to ground!

Diesels:

If corrosion is observed between the back of the engine block and the trans adapter housing, it may be easier to add a **heavy** ground cable from the adapter housing to the block rather than removing the adaptor housing to clean it.



Carefully peel back the plastic covering near the cable connector ends to make sure there is no hidden corrosion, seal it up if it's okay. If any corrosion is found, the cable must be replaced. Do **NOT** give this to your customer to fix. **You** need to fix it before starting the engine!

Bad grounds can **weld pumps** and mangle converter hubs and can cause an assortment of drivability complaints. Check for this issue **BEFORE** the job gets sold!

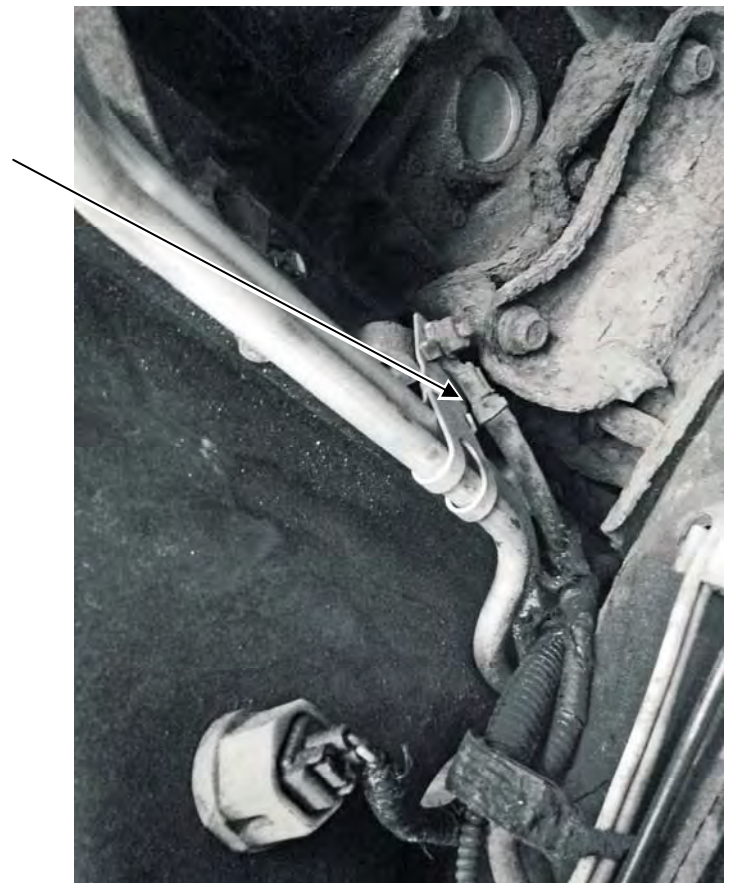

# 5R110W 5th Gear Ratio / Delayed Reverse Center Support Caused Complaints

A common tech call that we receive is how poorly the direct drum air checks through the center support. Many of the center supports that we tested had bronze particles imbedded into the side of the ring grooves preventing the rings from sealing. The bronze material is coming from the drum bushings. Always replace the drum bushings. A wire wheel on a drill or a piece of green scotch-brite used with a small screwdriver on a lathe are effective tools to remove the bronze build up. Once the imbedded bronze was removed a majority of the “bad” supports would now air check with 35-45psi. If the drum still does not air check after a good cleaning with new Ford rings #3C3Z-7D025AA the support ring groove is cracked, scrap it.



The arrows are pointing to the outside of the ring grooves where the rings need to seal. This is the area where the bronze particles accumulate and imbed into the support.



This picture can be viewed in color @ [transgo.org](http://transgo.org).

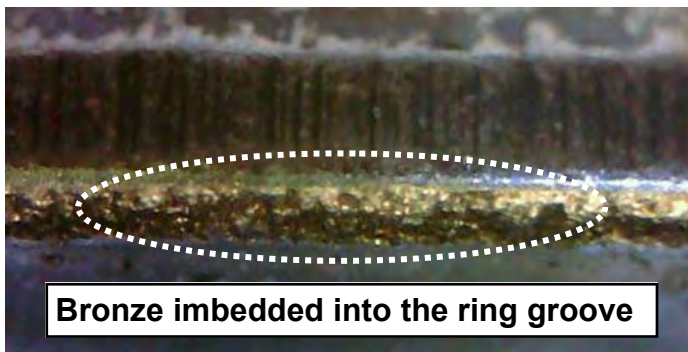

Here are some examples at 400x magnification:

**In Line Cooler Filter:** Trucks built prior to 2008 have a external in-line cooler filter. See fig 1.

**Proper Cooler Flushing:** Remove and discard the filter cartridge and temporarily plug the filter feed hole. See fig 2. Most housings have a .204" feed hole. Use a 6mm tap to carefully add enough threads to install a 6mm bolt 2-3 threads, hand tighten the bolt so it will not fall out. Reinstall the filter bowl (leave cartridge out) and flush the system. After flushing remove the filter bowl and bolt, clean out the housing and install a new filter cartridge and bowl.



Fig 1

Tap the filter feed hole enough to install a 6mm bolt 2-3 threads.

(If the hole is a different size, use the appropriate size tap and bolt).



Fig 2

**Pump Interchange:** 2008 and later trucks no longer have the in-line cooler filter. These models use a different oil pump. In a pinch you can use a 2008 type pump (2 notch) on the external filter models by permanently plugging the external filter feed hole. The in line filter type pump (1 notch) should not be used in place of a 2 notch pump. If the 1 notch pump is installed on a truck with **NO external filter** you run the risk of starving the gear train for lube if the oil cooler becomes restricted or plugged.

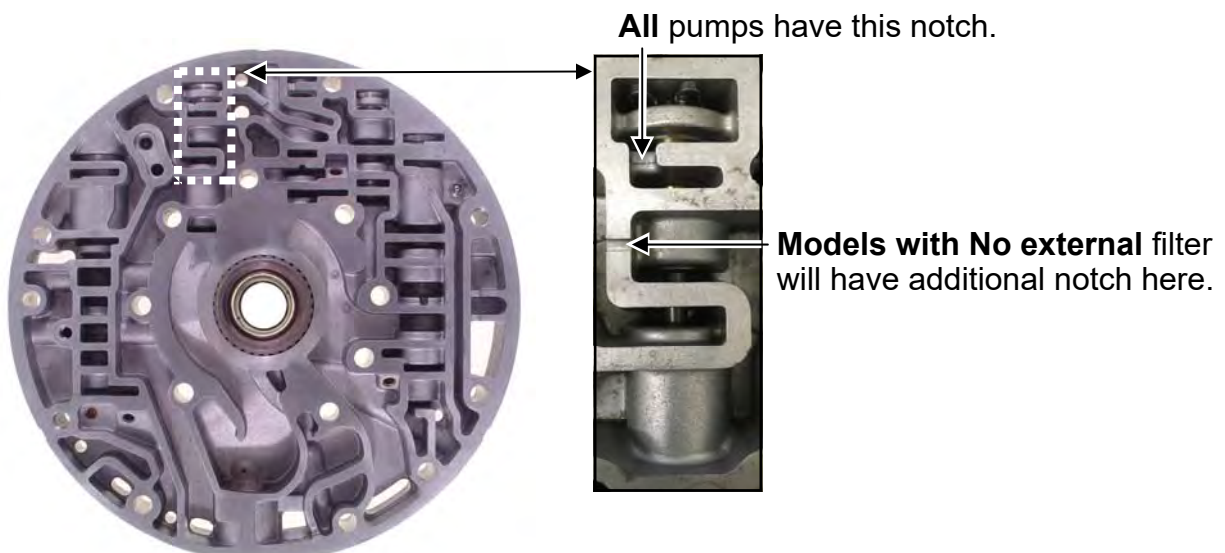

# SUMMARY

## **Keep Alive Memory Reset:**

Reset the KAM BEFORE starting the engine after overhaul. Clearing the KAM will tell the computer to forget the old trans and start with an all new beginning. Forgetting this step will cause the transmission to run at a higher pressure at start up which is hard on the pump.

## **Clearances, Pre-Lube, Startup & Filling:**

Pump bushing and gear clearances are critical!. Pump clearances MUST be checked if **ANY** parts are changed. See pages 1 and 3.

**DO NOT** use assembly gel or grease as lube for this pump. The gear pocket & both gears should be thoroughly lubed with ATF before assembling. Pour 3 to 4 quarts of the approved ATF into the converter before installing it.

*This is a **High Volume Pump** and it will run out of oil very quickly.*

**Pre fill** the unit with 8 quarts of ATF. Start engine and let it run for 15 seconds then shut the engine off. Add 5 more quarts then re-start the engine and complete the filling procedure. This along with the converter prefill will have the oil level within 1-3 qts of full depending on oil pan capacity. The ATF thermostat will not open until 150-185 degrees.

## **Before Road Testing, perform final ground voltage check:**

Hook negative side of Voltmeter to negative side of battery post set to DC Volts. Use the positive lead and probe the frame, the trans, the engine & the body looking for voltage above 0.05 volts key-on engine-off and 0.10 volts while running. Readings up to 0.40-0.50 on gas & 0.90 volts on 2 battery diesels is ok **briefly** during cranking. Voltage **higher** than this **DURING CRANKING CAN KILL THE PUMP!**

**Re-check level after road test.**



**Mr. Shift**

*Thanks for listening!*