

# SK® 62TE-A

Fits: 62TE 2007-on

## Corrects / Prevents / Reduces

- Overheating
- Drainback
- Delay or No Forward or Reverse
- Coasting 6-5 UD Apply Clunk or 3-2 L/R Apply Clunk

## If transmission is in Vehicle Skip Step 1

**Step 1.** Remove and discard OE L/R Housing Gasket. Install new **Non Shrinking Gasket** under Piston Housing. Gasket works great with all L/R piston housings.

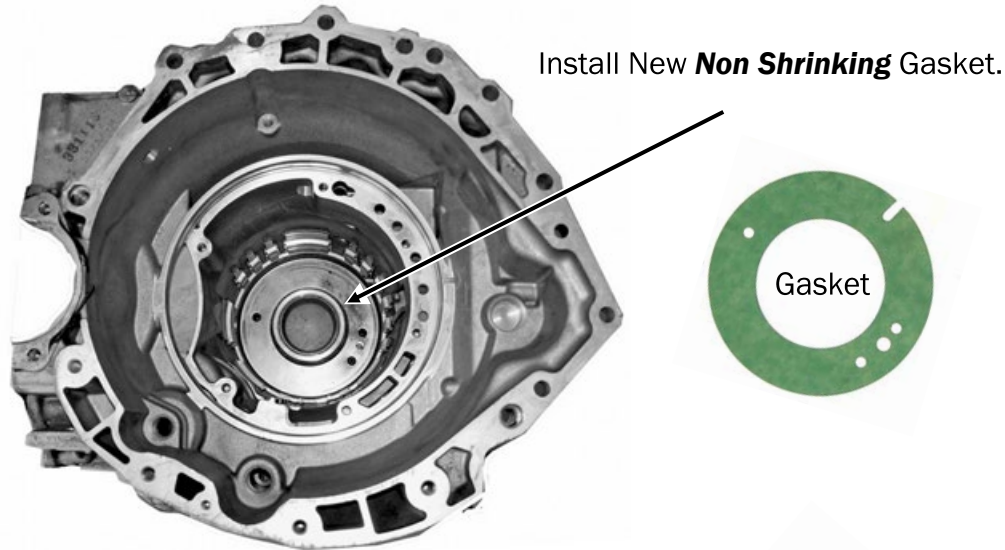

If housing is bent or has damaged holes from over tightening of retaining screws. Replace it!

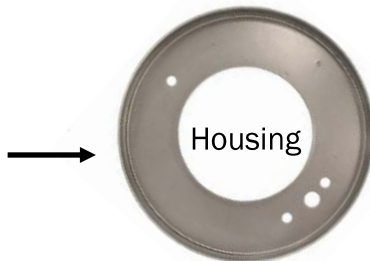

## Listen-Up!

The OEM retainer breaks often

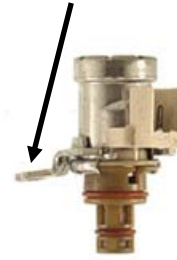

**TCC solenoid often fails and breaks** causing slipping or no move condition forward. Replace the solenoid and install our new retainer to prevent the solenoid from coming out when its original retainer breaks.

**Tech tip:** If the unit “chugs or kills” the engine at a stop, the TCC solenoid is bad.

## Now included in kit

Bracket #62TE-TCCSOL-BRKT prevents future failure.

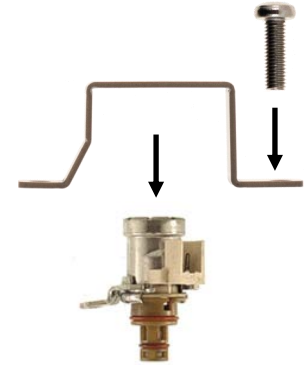

See separate instructions

**After every repair:** Always clear codes and reset the VLP Line Pressure Counter which is found under the Special Functions tab of the scanner.



# Accumulators

Do not make any changes to the Accumulator springs!

**Plastic Pistons:** Skip **Step 2** and re-use the original seals.  
 (Plastic Pistons get damaged from spring contact. Look inside where springs touch.)

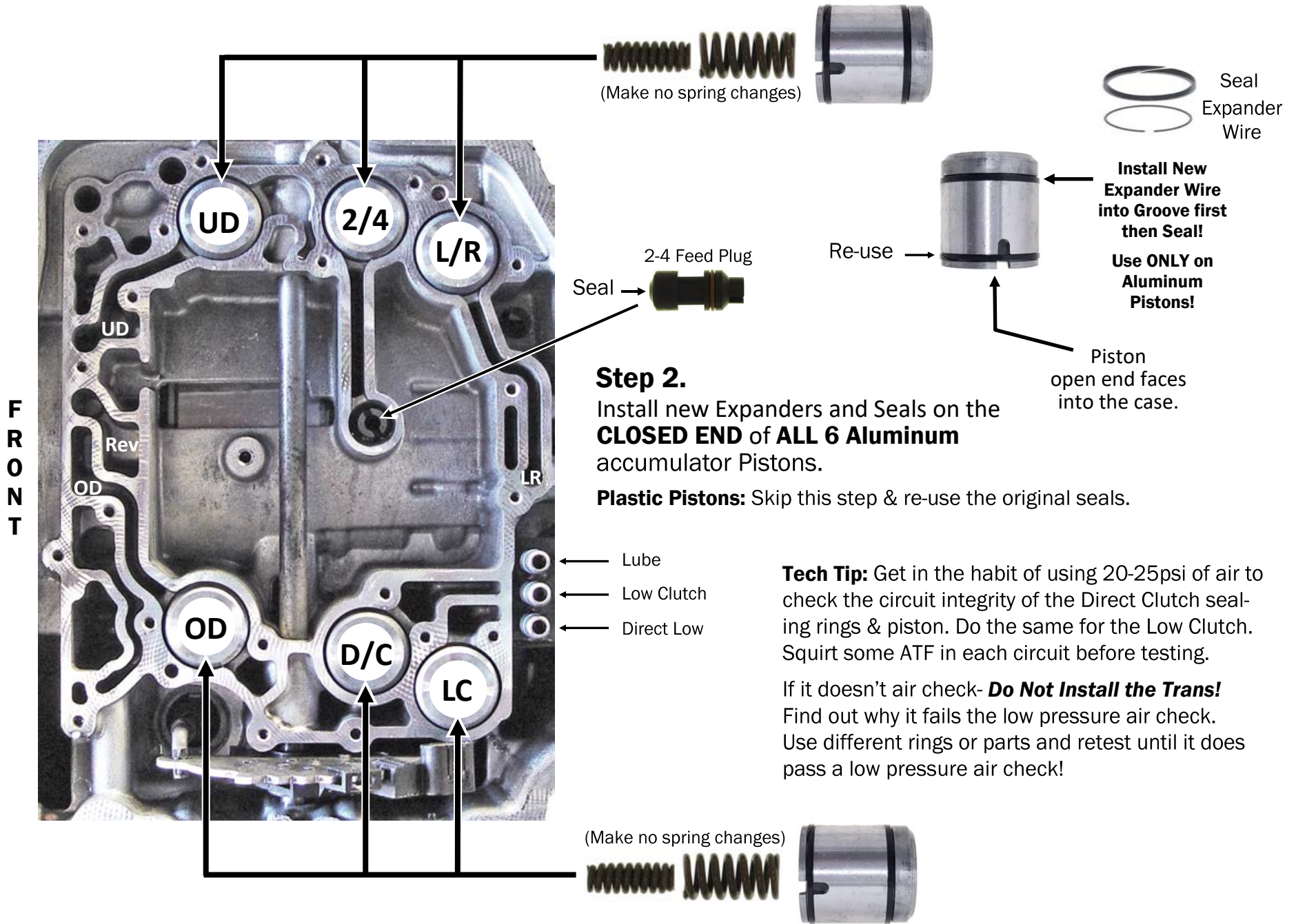

**Step 2.**  
 Install new Expanders and Seals on the **CLOSED END** of **ALL 6 Aluminum** accumulator Pistons.

**Plastic Pistons:** Skip this step & re-use the original seals.

**Tech Tip:** Get in the habit of using 20-25psi of air to check the circuit integrity of the Direct Clutch sealing rings & piston. Do the same for the Low Clutch. Squirt some ATF in each circuit before testing.

If it doesn't air check- **Do Not Install the Trans!**  
 Find out why it fails the low pressure air check. Use different rings or parts and retest until it does pass a low pressure air check!

# Valve Body Repairs

The repair work on this page will improve the overall **stability** of the **main pressure system** to **reduce shift complaints** as well as **correct** the malfunctioning Torque Converter Regulator to **improve** lubrication, cooling and **prevent** drainback from bore wear.

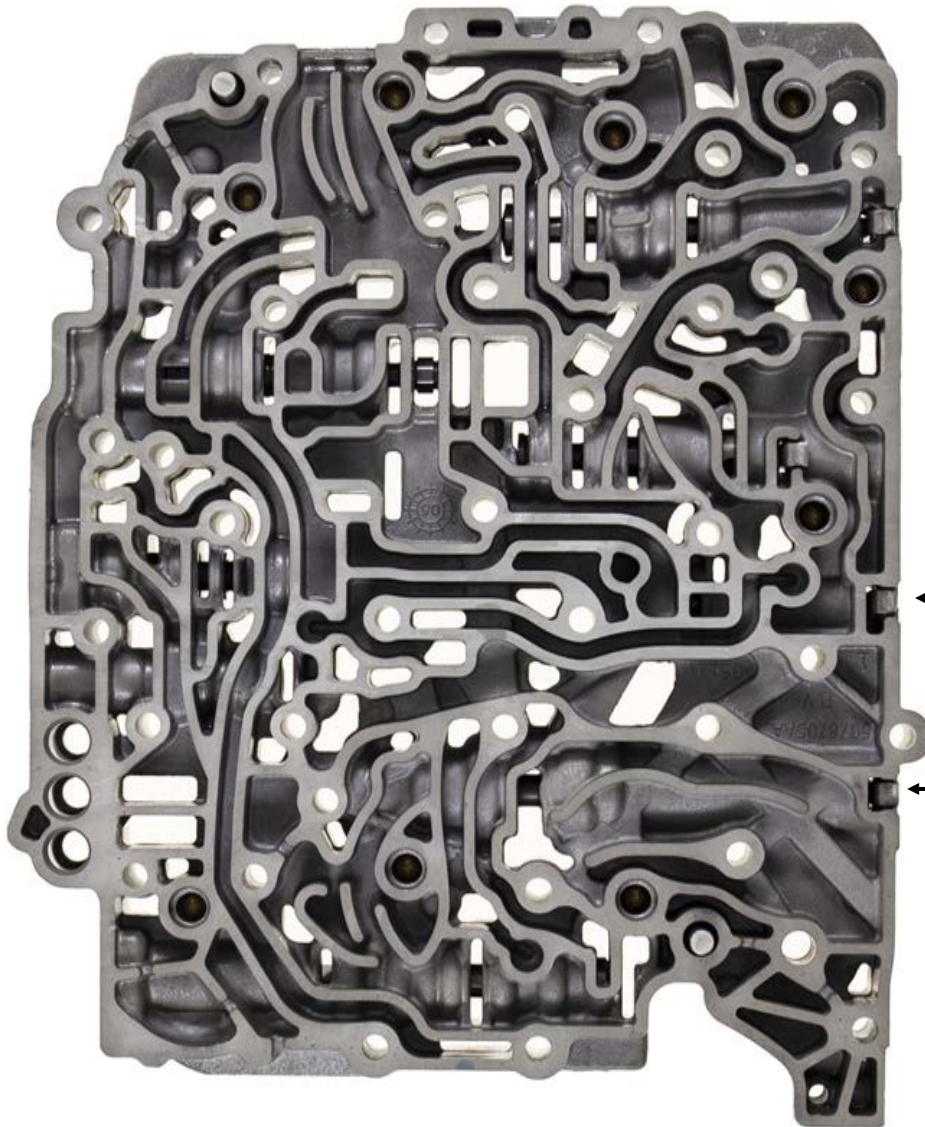

### Step 3.

Install **New TC Regulator Valve** checking that it travels freely then **New Orange Spring** & reuse retainer.

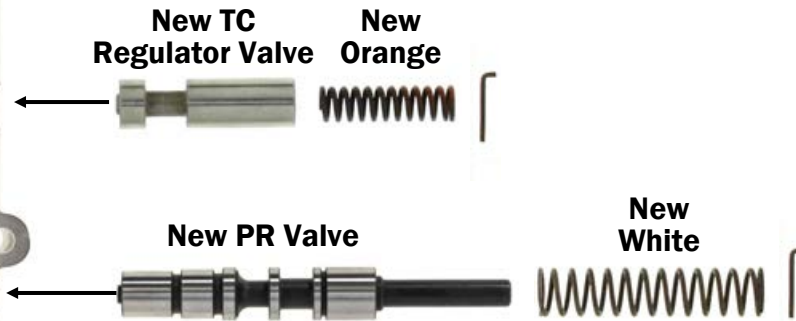

### Step 4.

Install **New PR Valve** checking that it travels freely then **New White PR Spring**. Re-use Retainer.

## New Product Available Now!

### TCC Slip, Pressure Switch Rationality codes?

Could be a worn **Solenoid Switch Valve Bore**.  
 Measure your solenoid switch valve and order:  
 p/n **RFE-SV420-WT** for **.420** diameter valve.  
 p/n **RFE-SV453-WT** for **.453** diameter valve.  
 Refills available just replace the WT with NT.

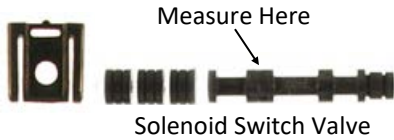

## 62TE Valve Body Additional Data

Typical 62TE Layout for reference only. Clean VB and reassemble. Return VB parts to their original locations.

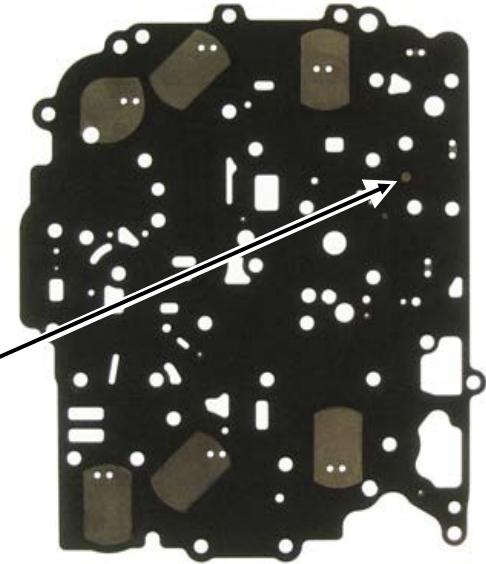

Install ball here only if plate has this hole.

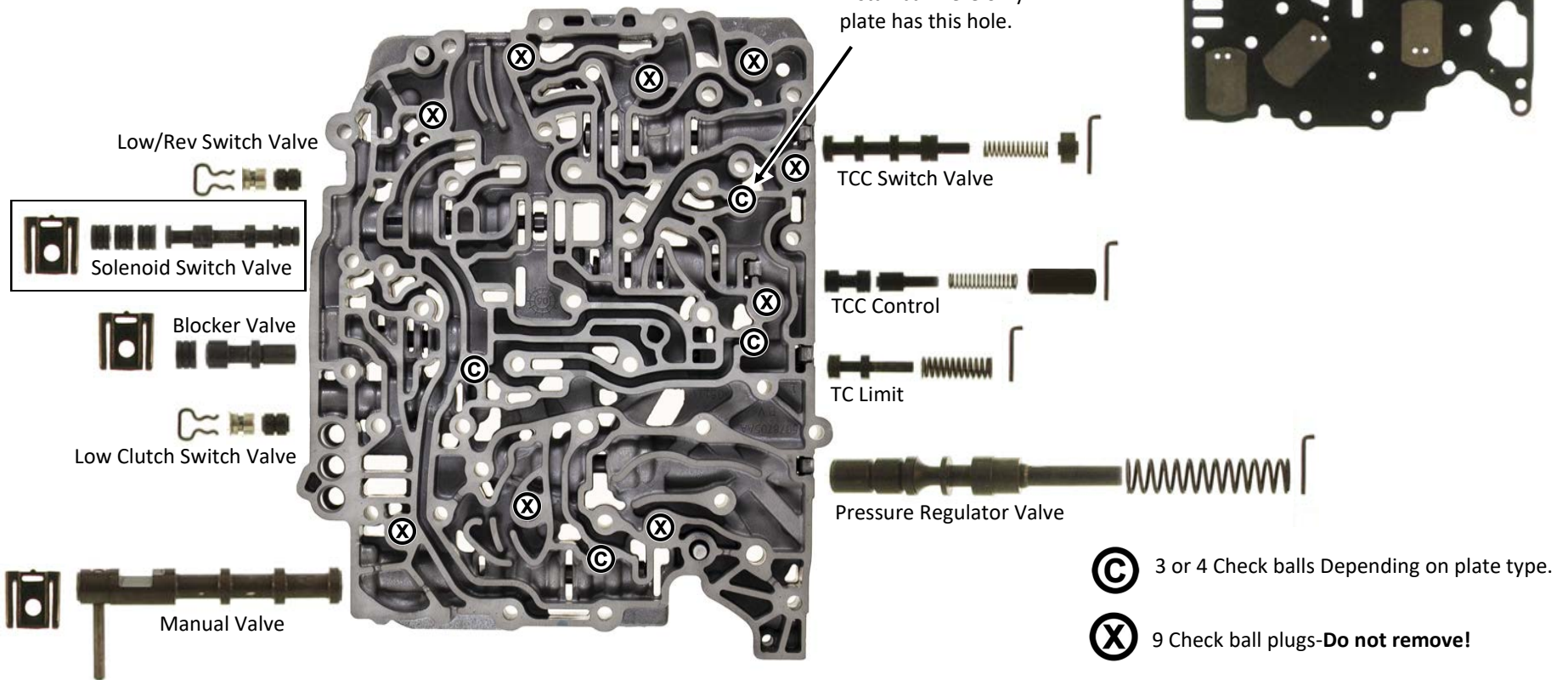

# Additional Data

The 62TE is a 6 speed transaxle. It has a 7th speed that is only used during a 6-4 kickdown, this 7th speed is known as 4th prime.

62TE Clutch Application									
Gear	Ratio	UD	OD	REV	2-4	L-R	LC	DC	ORC
1	4.127	On				On	On		Hold
2	2.842	On				On		On	
3*	2.284	On			On		On		Hold
4^	1.573	On			On			On	
4	1.452	On	On				On		Hold
5	1.000	On	On					On	
6	.0689		On		On			On	
Reverse	3.215			On		On	On		

3\* Is failsafe/limp mode.

4^ Is 4th Prime, used only on kick down.

Clutch's on the transfer shaft are: Low clutch, Direct clutch & the One Way clutch (ORC).

Transfer Shaft

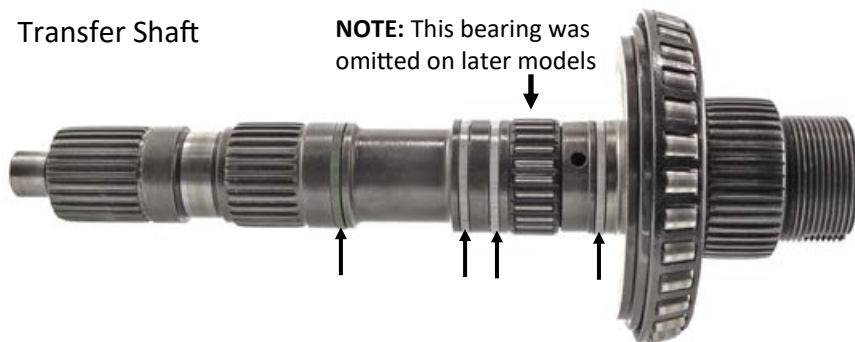

These 4 rings like to shrink dumping lube oil that can lower main line and accelerate ring land wear on the low clutch housing. 68018615AA

## Compounder One-Way Clutch

The **stepped side** of the outer race faces **into** the Low Drum. When sprag assembly is installed in the Low drum, the Outer **Race** must rotate Counter Clockwise while the drum held stationary.

*Flat side of outer race faces up when installed in Low Drum*

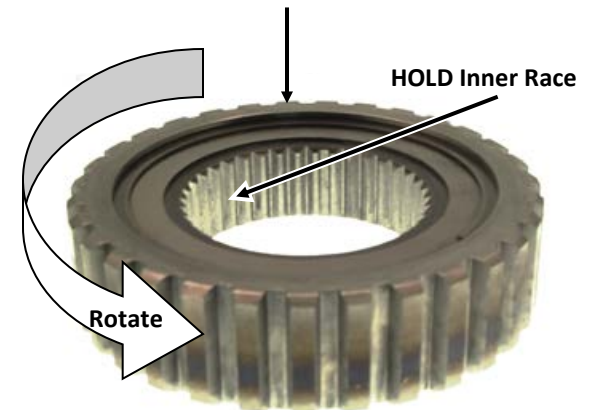

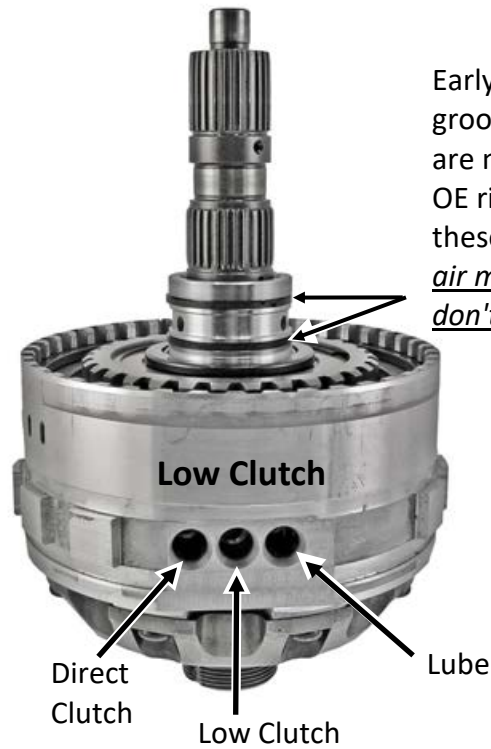

Early rotating rings usually destroy the ring grooves on low clutch housing. Later housings are notched for non rotating rings 05078800AB OE rings air check great and work excellent in these notched housings. 20-25 psi of regulated air must apply direct clutches on the bench, don't assemble unit until they do!

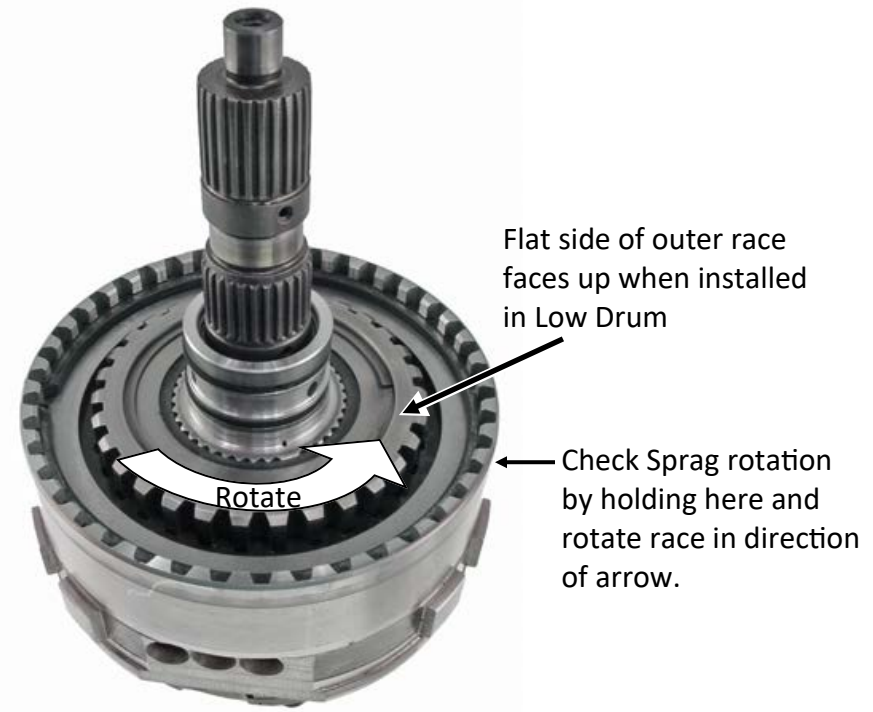

### Compounder Wear Areas

Loss of lube from shrunk sealing rings on the transfer shaft will accelerate wear on the ring tower causing Direct Drum rings to leak.

With severe wear, the top sealing ring may be found still in the drum here.

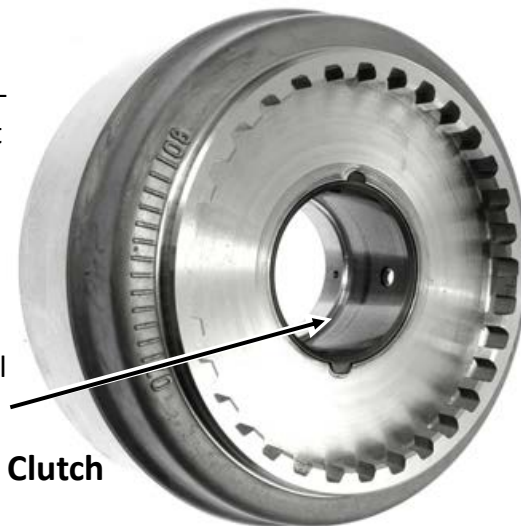

Direct Clutch

**Updating** the Low Clutch Housing to the latest Non-Rotating Ring type housing during overhaul is an great way to prevent rework due to ring groove damage. Even though it may not be damaged at time of overhaul, be warned, it does have a known high failure rate. Remember the customer pays for the parts now, you have to pay for them later.



Have a Great Day.  
Gil

# 62TE-TCCSOL-BRKT



**TCC solenoid often fails and breaks** causing slipping or no move condition forward. Replace the solenoid and install our new retainer to prevent the solenoid from coming out when its original retainer breaks.

**Indented side facing the transducer side of the VB**

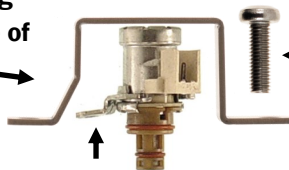

**Install New bolt on opposite side of indent.**

**The original retainer often breaks**

