

**SK® 6L80** Patent Pending Fits: 2006-2020 6L45 thru 6L90



**Corrects/Prevents/Reduces**

Extreme Pressure Damage Due to Worn PR Bore, **New PR Valve** Restores Proper Pressure Regulator Function, **New Boost Valve** Adds Over-Boost protection. **No special tools required to install!** Includes parts to repair **blown pressure switches**, **PLUS** our **New Design** sealing rings for **steel pump towers that use** rotating rings. Fixes the ring leaks that can cause 3rd & 5th ratio codes, delay or delay-bang forward or reverse engagements.

**New Product Available:**  
Got a cycling TCC or "chuggle" during a **Low Speed TCC** apply? Order **6L8 CS-TCC** from your supplier. See bottom of **Page 4** for more information.



**Great News! New TransGo® PR Valve** design increases support to **restore** proper valve function **EVEN IN A WORN BORE!**



**Step 1**  
Assemble EPC Relief 3/16" ball & Plain Spring into New Bushing & Spread the Cotter Pin legs.

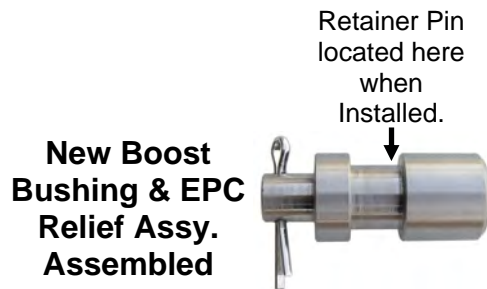

Retainer Pin located here when installed.

**New Boost Valve**

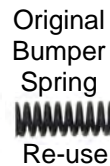
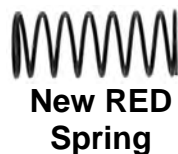

**New Spring Seat**

**Tech Note:**

This land is purposely undersized for additional lube flow. This helps prevent engine chug while coasting to a stop, when hot.

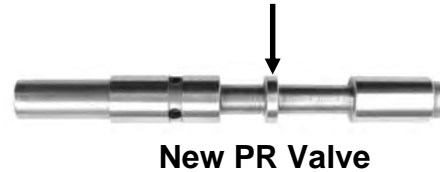

Retainer Pin (Re-use)

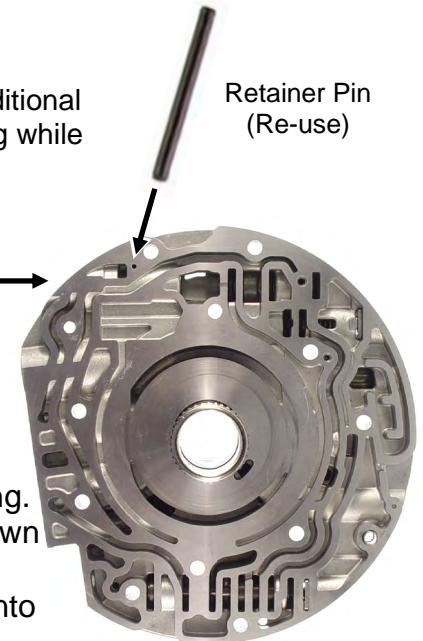

**Step 2**

Remove & discard original Retainer, PR Valve & **LARGE** PR Spring. Assemble **New Spring Seat** on **New TransGo® PR Valve** as shown above and insert into Pump. Re-use original bumper Spring with **New RED PR Spring**, then install **New Boost Valve** into **New Boost Bushing Assy** & re-use original retainer pin.

The Original Bumper Spring & The **NEW RED PR SPRING** **MUST BE USED WITH THE NEW TransGo® PR VALVE.**



Discard Original Boost Assy. PR Valve & Large PR Spring.

# Rotating Pump Ring Installation

**Read this:** If your pump stator's ring groove area is made of **steel and uses rotating rings**, then installing our **NEW** design sealing rings and expander wires will fix the leaky ring issue with those stators and therefore updating the stator to the non rotating ring type stator is not required.

Do not use the new rings on **aluminum ring grooves!**

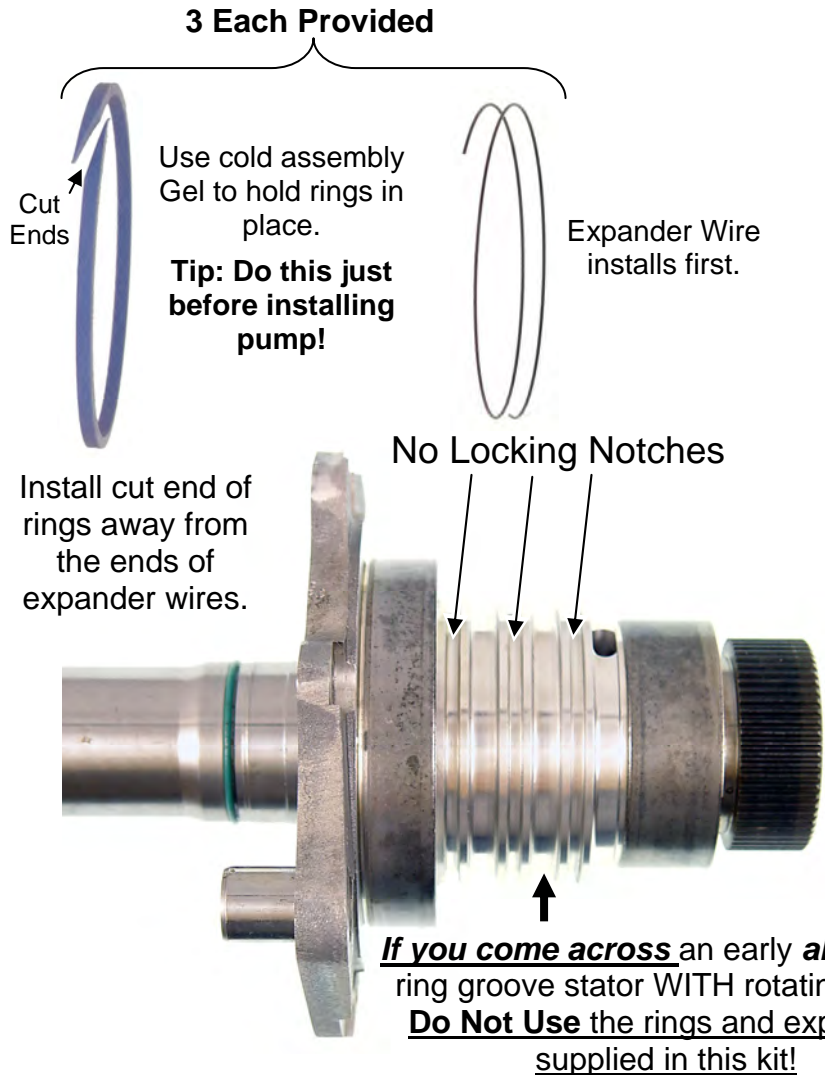

## New Rings only FIT Stator's WITHOUT Locking Notches!

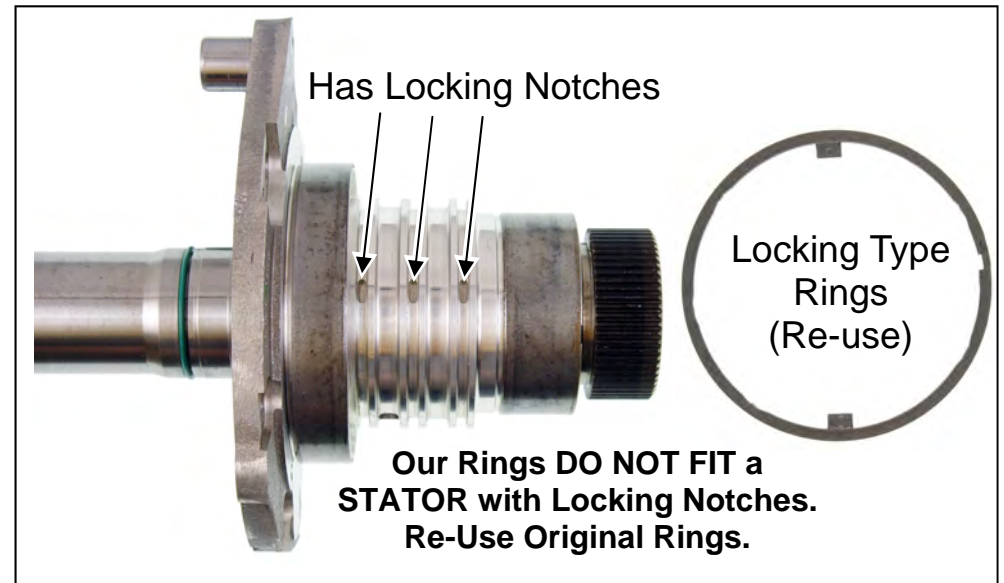

**2.** Put some cold assembly Gel into each ring groove, then install the **New Sealing rings** like this.

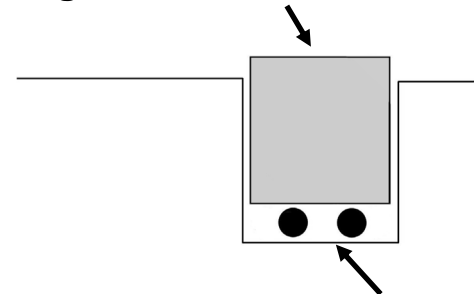

**1.** Install **Expander Wire** in bottom of ring groove **FIRST!** Make **SURE** wire ends do not cross over each other. They should lay side by side.

# Upper VB Repair

Depending on bore condition, you may need to Gently tap the bushing into place. That's ok.

Top of Gold Retainer MUST be below VB surface!

After install, the 2 holes in the new bushing will be visible here.

Guide Pin

Bushing

New Solenoid Regulator Valve

Orange Spring

Spacer

Gold Retainer

Grind top if retainer is too tall for your casting!



## Step 1

Remove and discard original Solenoid Regulator Valve, Spring & Retainer. Clean out bore. Rinse & Install **NEW Bushing, New Solenoid Regulator Valve, New Orange Spring, New Spacer & New Gold Retainer.**

You just fixed the wear issue with this simple to install fix.

The rest of the pages are general information and include the TEHCM Pressure Switch Repair Info.

## Additional Information

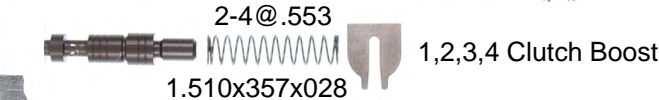
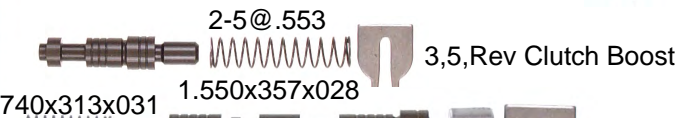
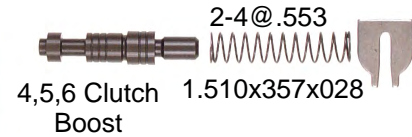

### MEASURE CHECKBALLS!

No forward or Reverse can be undersized Checkballs!

- © = 7 .250 Check Balls
- ⊗ = 1 Late VB's have an extra .250 ball at this location.

Have a great day!



Mr. Shift

# Additional Information

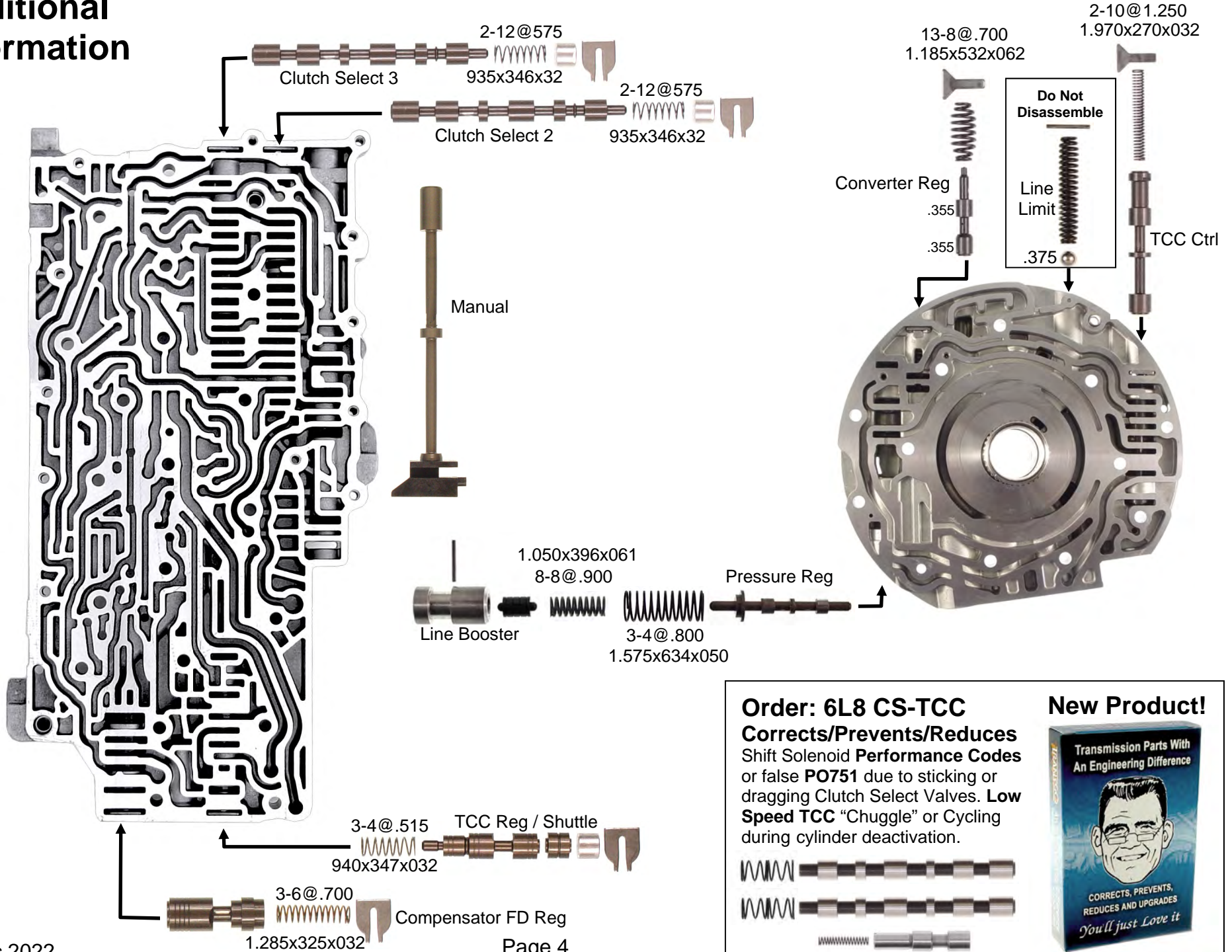

**Order: 6L8 CS-TCC**  
**Corrects/Prevents/Reduces**  
 Shift Solenoid Performance Codes  
 or false PO751 due to sticking or  
 dragging Clutch Select Valves. **Low**  
**Speed TCC** "Chuggle" or Cycling  
 during cylinder deactivation.



**New Product!**

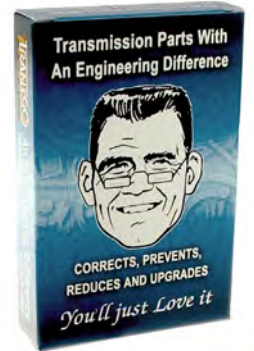

# TEHCM Pressure Switch Repair

Often this trans experiences a drum or clutch piston failure often due to a Pressure malfunction. Typically, at least 2 of the 4 pressure switches in the assembly **will also be blown out** as shown below. **Your choice** is to **repair the TEHCM** with this kit or **replace it** with a new **TEHCM** from the dealer & have it programmed. **\$\$\$!**

We have provided the parts you need to **repair** the pressure switches. It does take a bit of talent but mostly **PATIENCE** to get it done. Many techs have performed this task with great success but it's **your choice**. You need only repair the switches that are damaged.

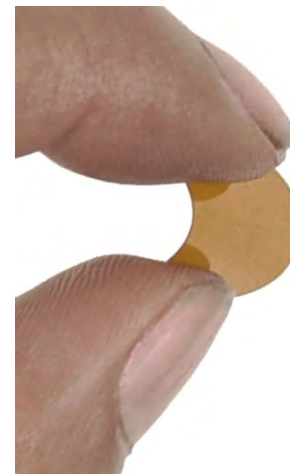
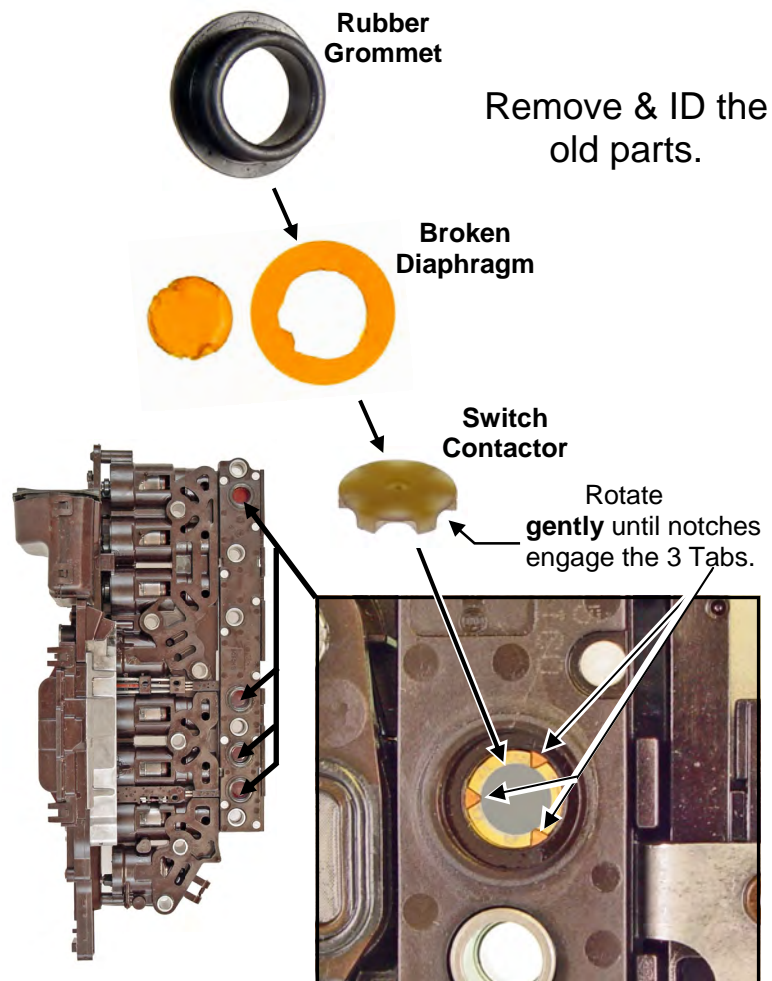

Pinching Diaphragm for installation.

## Testing switches:

Using a flat washer and a rubber tip blow gun, place the flat washer over the rubber grommet and insert the blow gun tip into the center of the washer. Air check each switch that is not visibly damaged and make sure they hold air. **If they do**, leave them alone!

If they don't, or you see they are visibly damaged, remove the rubber grommet, the damaged diaphragm and insure the switch contactor is in place. Pushing on the switch contactor, you should **feel** a noticeable click as you release pressure off the contactor.

Take one of the new diaphragms, gently pinch the diaphragm into the shape of an upside down taco shell. Insert it as shown below into the switch hole making sure you guide it under the lip of the plastic. Using a small **flat-blade** screwdriver, work the rest of the diaphragm into the hole until it lays flat on the switch contactor. You may use a pencil eraser to move it left or right till it drops in place. **Continue on next page.**

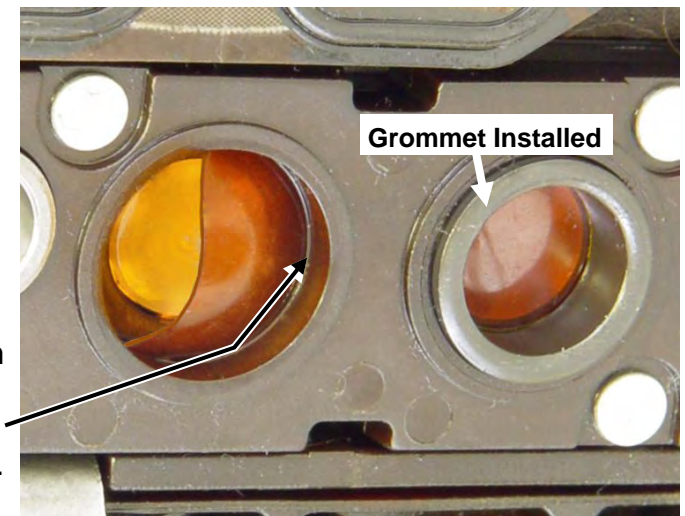

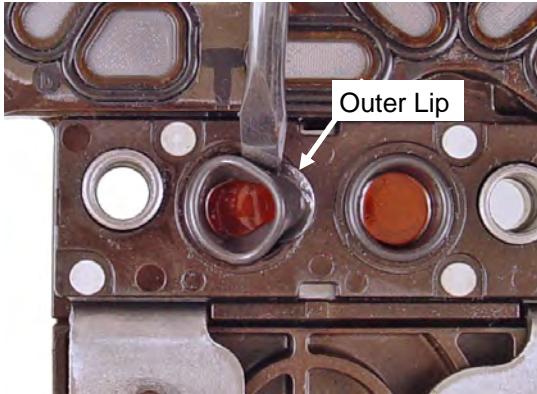

A **Small Flat Blade** screwdriver works best for doing this!

Pinch the Grommet to start the outer lip under the plastic. Work the outer lip under plastic with a small screwdriver.

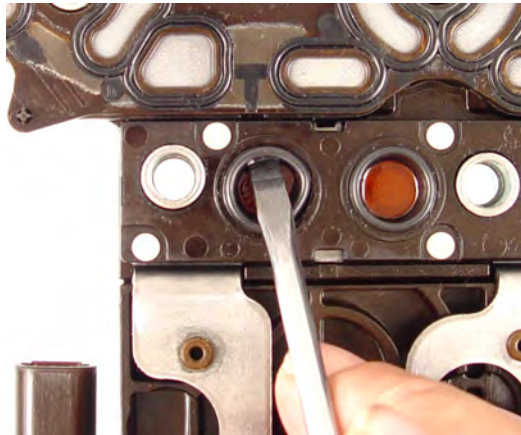

Use the small screwdriver to push behind the outer lip (from the inside) to wedge it under the plastic.



You may have to pull the top of the grommet back slightly to make sure the lip is going under the plastic.

## Rubber Grommet Installation

Installing the grommet is done by **patiently coaxing** it into position. You **must** get the **outer lip** of the grommet to go **under** the plastic housing. This is what seals the switch. Lube the grommet & diaphragm with 90w gear oil or something equally as slippery. Treat this just like you would a small child– with patience! The first one is always about getting the knack of doing it. Be successful and you'll be putting cash in your pocket for each TEHCM you didn't have to buy new & then program.

## Final Testing

Using a flat washer on the rubber tip of a good blow-gun, make sure the switch does not leak. It should seal tight. Do the air test with 30 psi. If it holds, it's ok. It will be too hard to hold the blow gun in place to use full shop air.

**Final test:** Use a pencil eraser to gently push into the center of the switch to feel the switch click as you let up on it. Use one of the other switches to compare. The new grommets **will** be taller than old ones. It's OK!

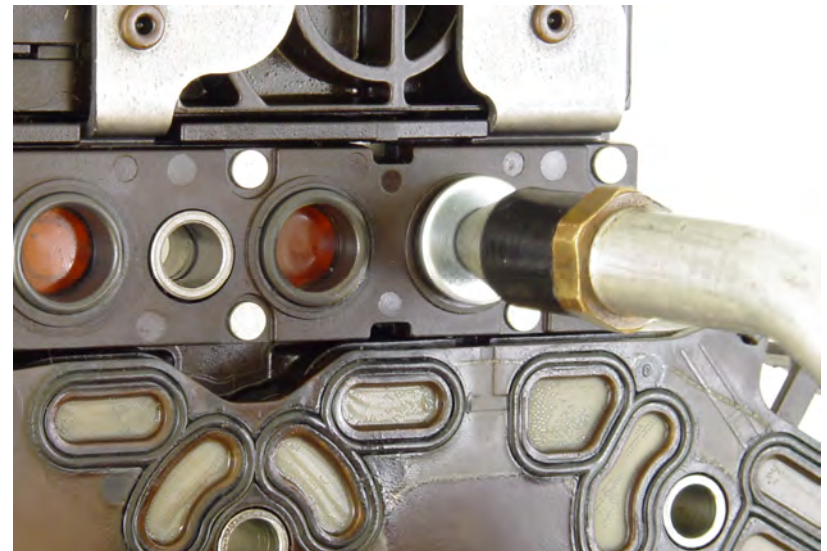

# Additional Information

The blowouts are easy to see.



## Watch for cracked pistons throughout this unit!

What breaks depends on what gear the trans was in when the extreme pressure malfunction occurs. The 1-2-3-4 clutch area shown is one of the more common areas to fail due to extreme pressure.

Complaints can be no 3rd, 5th, Reverse, Forward or falls out of gear at a stop when hot.

However, the Hairline Cracks are not!



Cracks in this housing can cause no Fwd. and/or no Rev.

1-2-3-4 Clutch Housing

**Wash parts and blow dry with compressed air before looking for cracks!**  
**Keep a magnifying glass handy if you have less than youthful eyes!**

### WARNING!

**When replacing pistons and related parts, MAKE SURE they are the same diameter as parts your replacing. Differences can be as little as .045"!**

**LOOK CAREFULLY!**



1-2-3-4 Clutch Piston

# Additional Information

Pay attention to the location of the Lower & Upper Snap-ring **Stop Lug** in the Drum. The **open ends** of each snap-ring **MUST** be located on either side of the lug.

The lower and upper stops are located 180° opposite of each other in the drum. (Lug has no groove for snap-ring!)

Lower Stop Lug

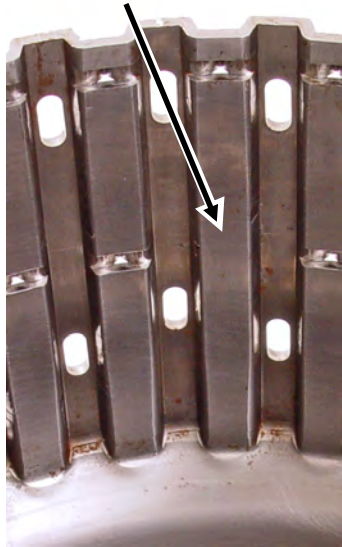

Upper Stop Lug



1,2,3,4 / 3-5-Rev Drum

If mis-located, it may take as much as 3 weeks for the snap-ring to become dislodged & set solenoid performance codes. This is usually but not limited to complaints of no forward and or no reverse **after overhaul**.

Look carefully for hairline cracks on the front of the drum! You may need a magnifying glass to see the crack. In our opinion if the clutches were damaged or the vehicle had a Forward, 3rd, 5th or Reverse complaint, it's far safer to replace the drum as an assembly then risk the re-work.

High torque transfer or shift shock can damage the drum but not crack the pistons. However, It's the high pressure that can damage both the drum and or the pistons. Fixing the extreme runaway pressure is key to keeping the parts alive and that's what this product is all about.

