

SK®6R80

Fits: Ford/Lincoln 6R60, 75 & 80 All Gen 1 (2006 UP)

*All Ford/Lincoln Vehicles with ZF Trans use Ford Instructions!

Reduces/Corrects/Prevents

28 to 46 MPH "TCC Quiver", Erratic Pressure due to PR malfunction, Rough Shifts, TCC slip, Coast-down Clunk.

***For Imports Models With:**

ZF6HP19, 26 & 32

See Separate ZF Instructions.



Some 2014 & early 2015 models along with some new replacement Gen 1 VB's may visually resemble Gen 2's with the extra filter hole on the bottom of VB & may have added VB to case bolt hole, but still use the Gen 1 PR Valve. Ford parts book show all vehicles built **after 12/2014** have a Gen 2 VB but to confirm Gen 1 or Gen 2, **always measure the PR valve on next page to be sure your installing the correct Kit. This Kit fits all Gen 1 only.**



Ford/Lincoln 6R60, 75 & 80

*Mark each Solenoids location
before removing them.
Always return them to the same
location.*

Ford/Lincoln 6R80 04/2014 On Style

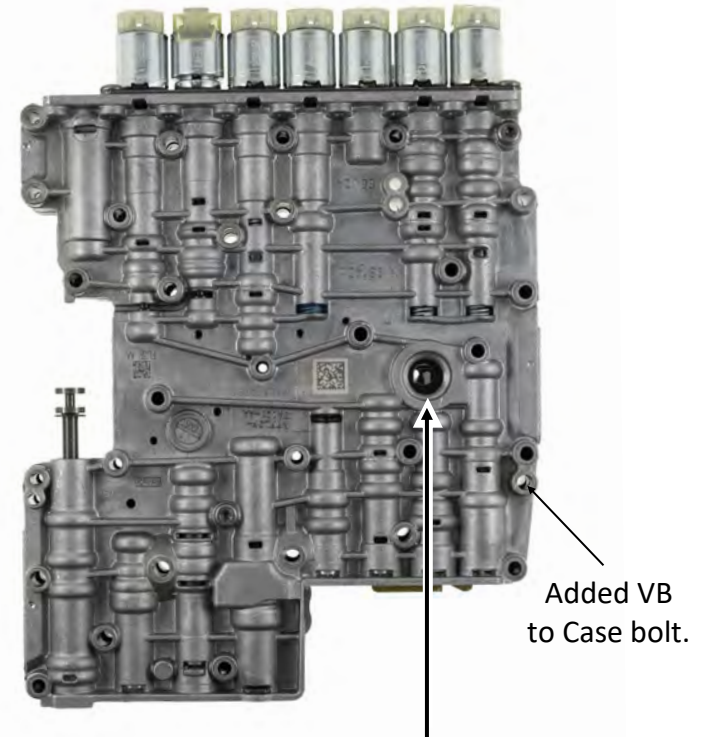

Some late Gen 1 and all Gen 2 VB's have this extra filter hole here. Only Gen 2 models with Start Stop use it, they will have filter grommet here & use a two neck filter also a small electric auxiliary pump on the passengers side of trans. **Always ID Gen 1 or Gen 2 by measuring PR Valve on Next Page.**

Step 1

Remove & measure your Original PR Valve as shown to make sure you have the correct Kit. **Note:** This page **only applies to Ford/Lincoln Gen 1 Valve-body's** with stock O.E. Bore Sizes!

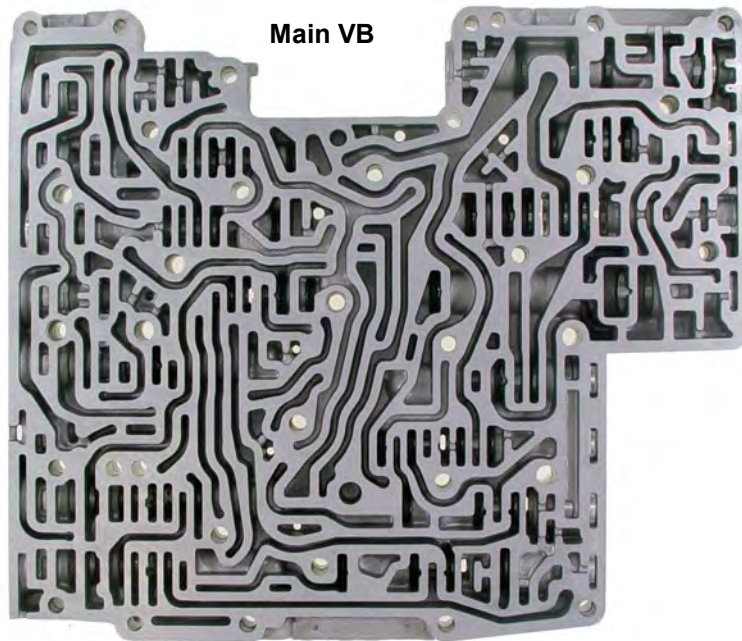
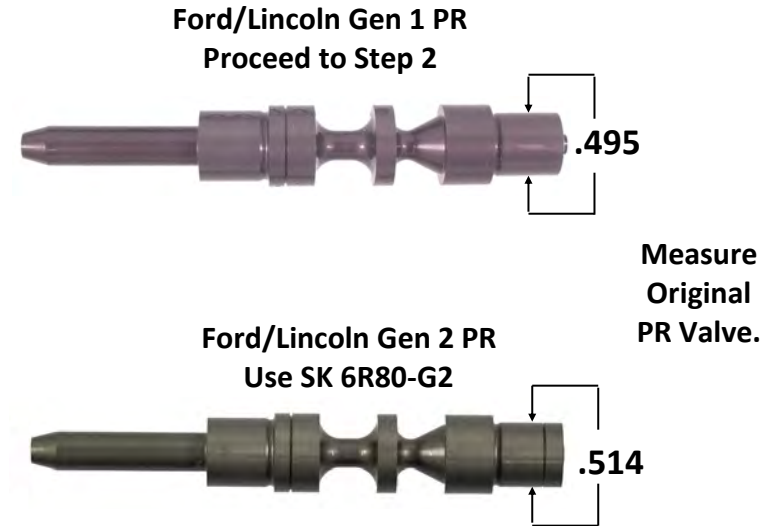

Step 2

With original PR valve measurement of .495" Install New replacement **Orange** PR Spring, PR Valve, No ID groove End Cap & re-use original retainer. Make sure New PR Valve is free in the bore before final assembly.



High Mileage Valve Body?

140,000 Miles plus VB's can have excessive wear in the **Lube Regulator & Solenoid** Regulator bores. This wear can cause complaints of persistent Coast Down Clunk Hot, Ratio Codes, Long Slip or Sliding Shifts Hot & Premature Gear Train Bushing failure. Order TransGo P/N **6R80-VBR-WT** and fix both! High Mileage VB's also need a fresh set of solenoids.

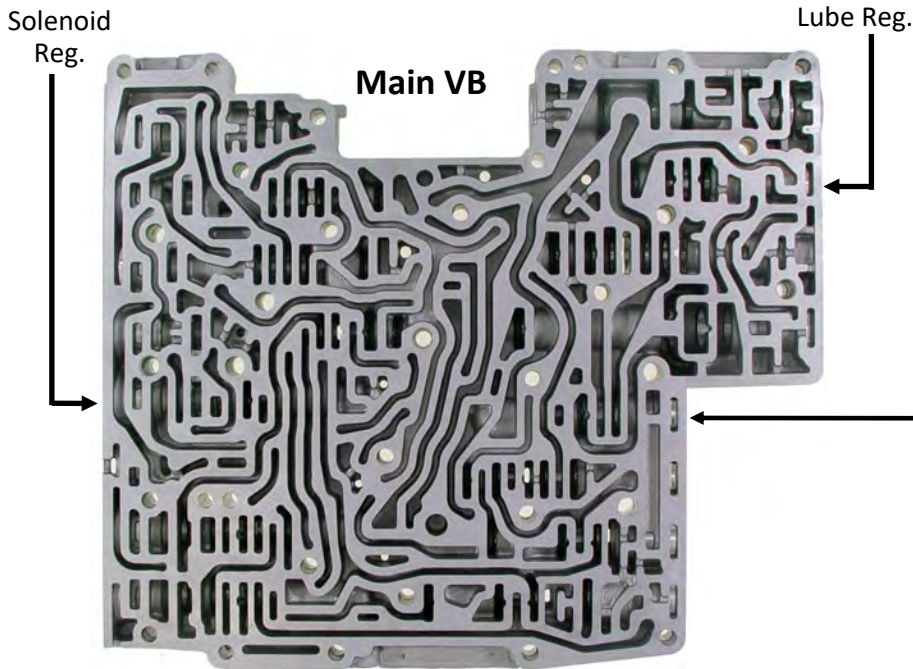

2006-2010 Solenoid Replacement.

- (3) Brown Connector 6L2P-7G383-AD
- (3) Black Connector 6L2P-7G383-BD
- (1) SSE 6L2Z-7G484-AA

2011 Up When replacing any or all of the VFS solenoids look **carefully** between the QR code and the plastic connector for the calibration # 2 thru 5. Always replace with the same number that came off in each location. SSE is a on/off solenoid with no calibration ID.

2011-2019 SSE AL3Z-7G484-B.

6R80 TCC Information:

Some customers may describe a complaint of a vibration or "Quiver" that feels like a tire problem but it isn't. Here's the skinny... If the customer's been chasing this complaint for more than a month or two, you will need this kit **AND MAYBE** a new converter. *However*, shops installing this product with a fresh refill of Mercon® SP Fluid say it usually fixes the issue even if it's been doing it much longer.



Always check each wire retainer as they break often. For your convenience, extra Retainers are provided.

Step 1

Discard original TCC Regulator Valve and Spring. Install **NEW Steel TCC Regulator Valve** and New small **White** spring provided reuse end plug & retainer.



2011 Up VFS Brown Snoot
TCC, SSA & SSC



- Solenoid Calibration ID #
- Brown # 2 AL3Z-7G383-S
 - Brown # 3 AL3Z-7G383-T
 - Brown # 4 AL3Z-7G383-U
 - Brown # 5 AL3Z-7G383-V

2011 Up VFS Black Snoot
SSD, EPC & SSB



- Solenoid Calibration ID #
- Black # 2 AL3Z-7G383-K
 - Black # 3 AL3Z-7G383-L
 - Black # 4 AL3Z-7G383-M
 - Black # 5 AL3Z-7G383-N

Additional Information for Gen 1 Ford Models

Re-install ALL small parts to their original locations!

If the **Separator** plate has a hole OVER a dampener location, a dampener MUST be installed IN that location. **Some models only use 2 dampeners.**

Watch for damaged/crushed pulse dampeners. 6 Replacement inserts are included!

New Replacement Insert. Re-Use Dampener Outer Shell.



All Gen 1 Fords

⊙ = 8 Check Balls

⊓ = 6 Dampeners

Watch for damaged plate printing! Splitting the VB halves usually pulls the printing off.

Ford 2006 thru 4/2014 Plates

6 Dampener Plate P/N: CL3Z-7Z-490-C

2 Dampener Plate P/N: CL3Z-7Z-490-D

****Some 2014 & Early 2015's Gen 1 Ford's Use a Different Plate. Quick ID- Has added filter & case to VB bolt holes. Plate P/N: FL3Z-7Z490-E Its Similar to a Gen 2 plate but different.**

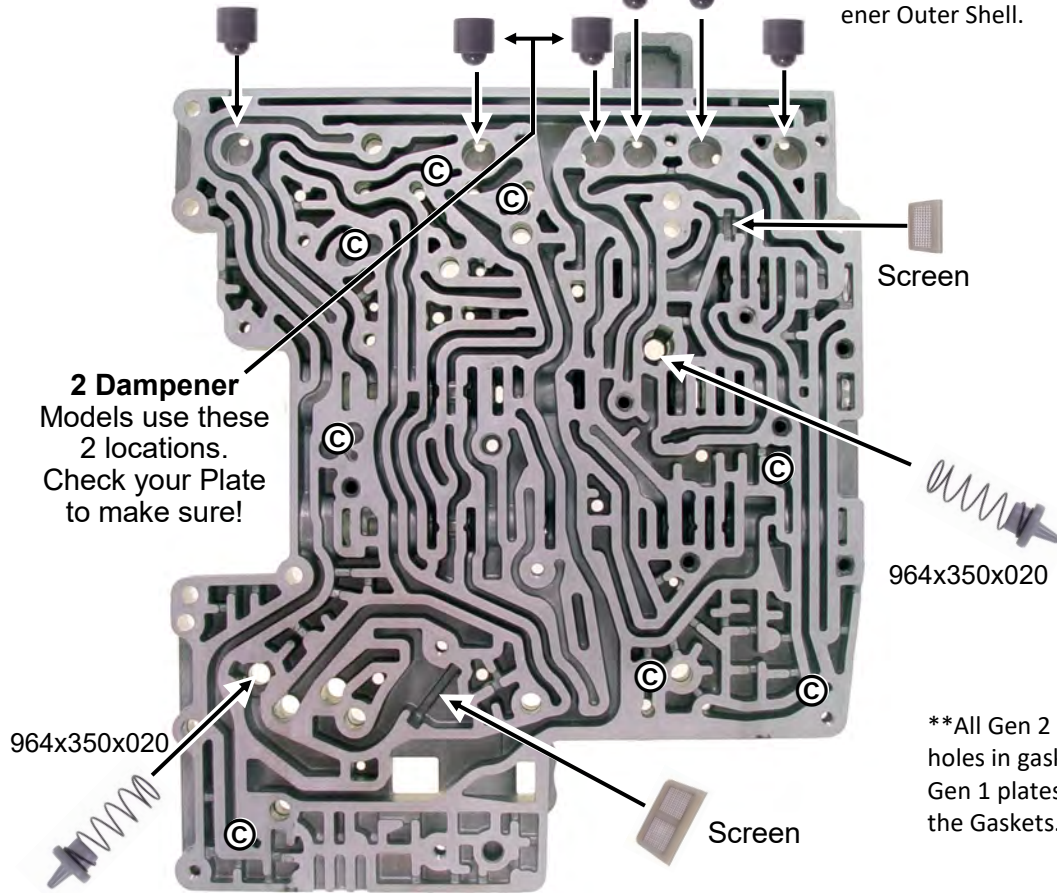

2 Dampener Models use these 2 locations. Check your Plate to make sure!

964x350x020

****All Gen 2 Plates will have these 2 holes in gaskets & plate. The late Gen 1 plates just have the holes in the Gaskets.**

Fluid level must be at top of hash marks with trans temp @ 190F degrees to purge air from cooler circuits! Use scan tool to determine fluid temp. Don't let it out the door with a low fluid level! Do not overfill either!

Plates may be printed. or have bonded gaskets.

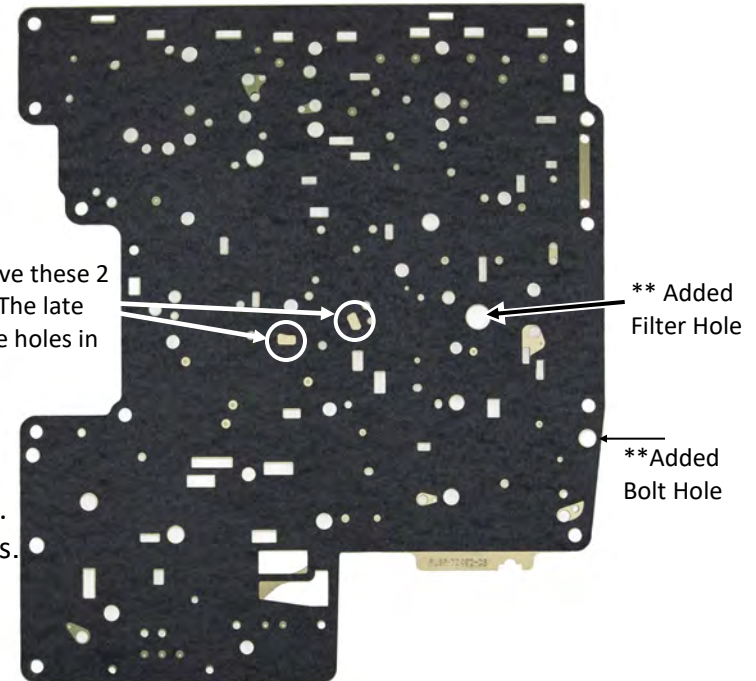

SK®6R80

Use this section for Import Models with
ZF6HP19, 26 & 32 (Non Ford/Lincoln)

Reduces/Corrects/Prevents

Erratic Pressure due to PR malfunction,
Rough Shifts, TCC slip, Coast-down Clunk.



This kit fits ZF6HP19, 26, & 32 model Valve Body's with a Vent.

(Small or Large Vent as Shown Below)

This kit does NOT fit ZF6HP-21, 28 & 34's

(Valve body's without a Vent)

ZF6HP-19, 26 & 32 Typical M Shift

ZF6HP-19, 26 & 32 Typical E Shift

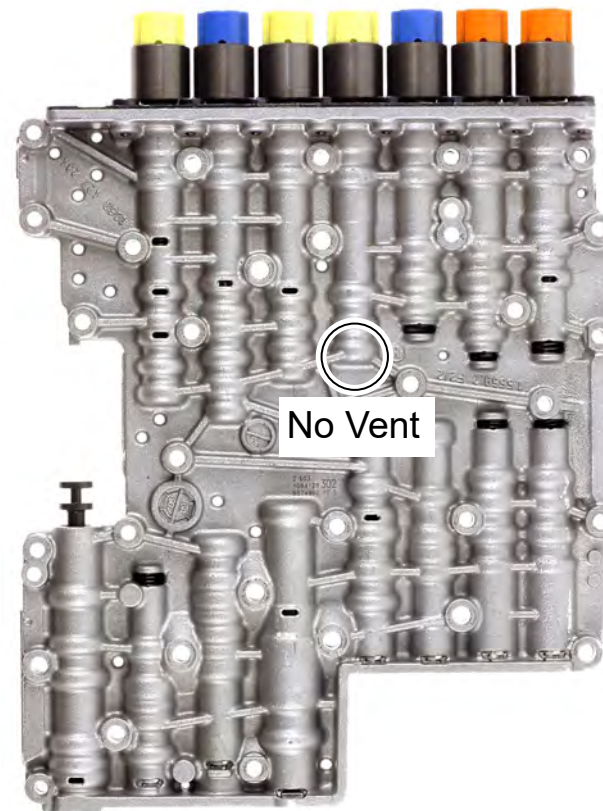
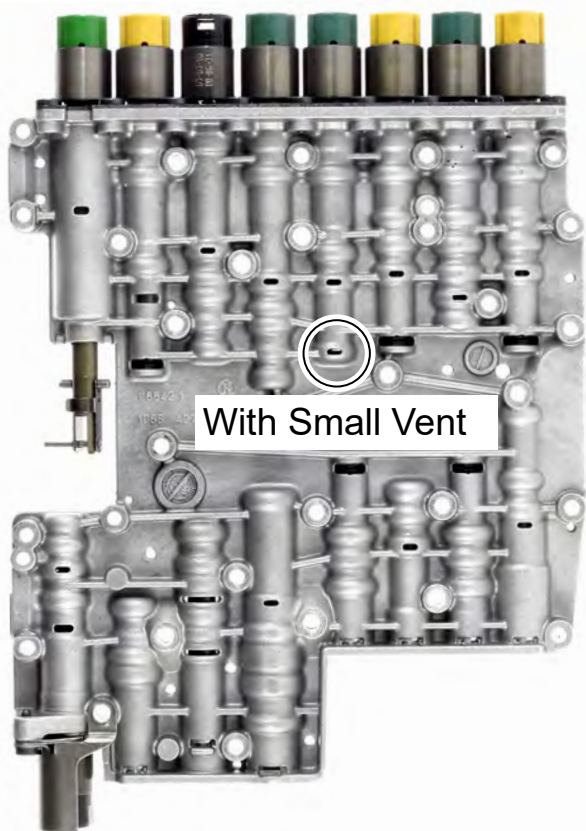
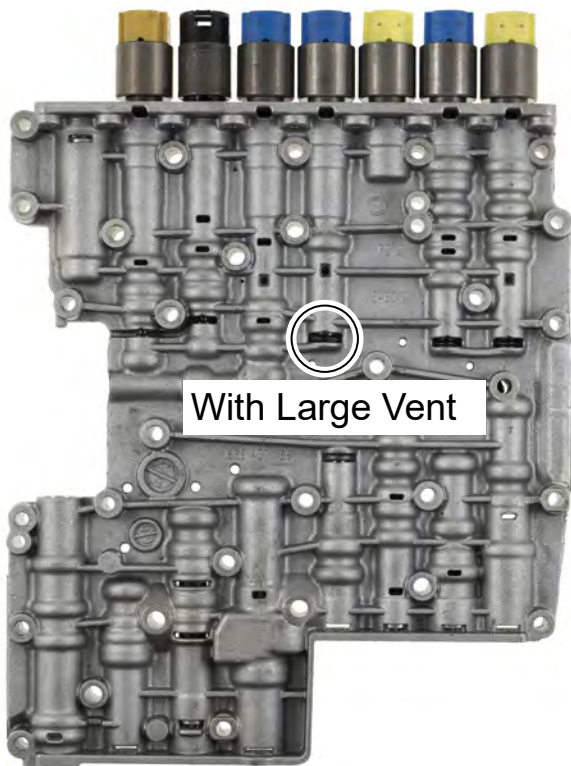

Step 1

Measure your **PR Valve** as shown and use the **Step** that matches your PR Valve's measurements. **Note:** This product **only fits** stock O.E. Bore Sizes!



This product **DOES NOT FIT** VB's with this valve type. See ZF front page for ZF Valve Body ID.

Use this page for ZF6HP-19, 26 & 32

Step 2

ZF's 19, 26 & 32 without 053 Separator Plate:

With original PR valve measurements of **.495" & .575"**

Install New replacement **Orange** PR Spring, PR Valve, No ID groove End Cap & re-use original retainer. Make sure New PR Valve is free in the bore before final assembly.



Step 3

ZF Models with 053 Separator Plate:

With original PR valve measurements of **.511" & .650"**

Install New replacement 2- I.D. Groove End Cap & re-use *original* PR Valve, PR Spring and retainer.

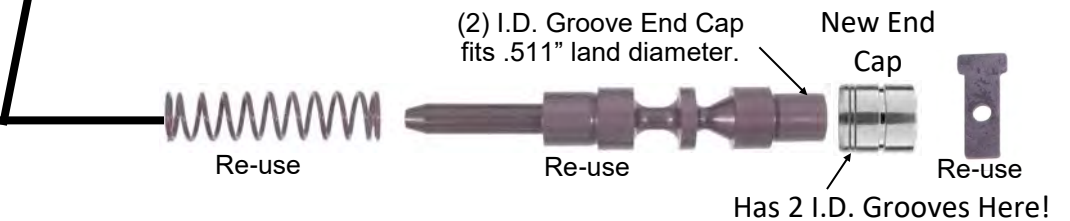

Step 4

Discard original TCC Regulator Valve and Spring Install **NEW Steel TCC Regulator Valve** and New small Red spring provided reuse end plug & retainer.

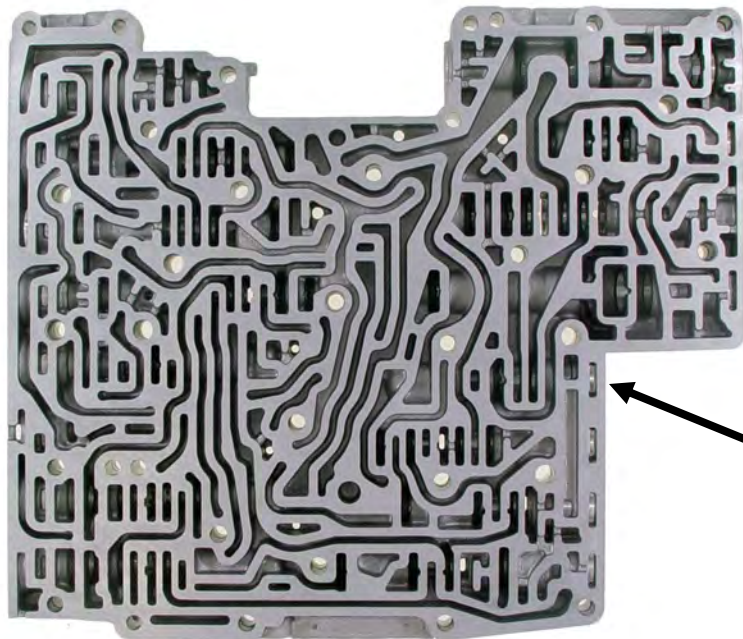

Additional Information

Typical M-Shift Valve Body Layout

Tech Tip: High mileage vehicles often have discolored/overheated Solenoids and should be replaced.

Mark locations of ALL small parts and re-install as you found them. They are model specific.

Note: Valve's marked with an * asterisk may or may not have a spring and are vehicle software/model specific.

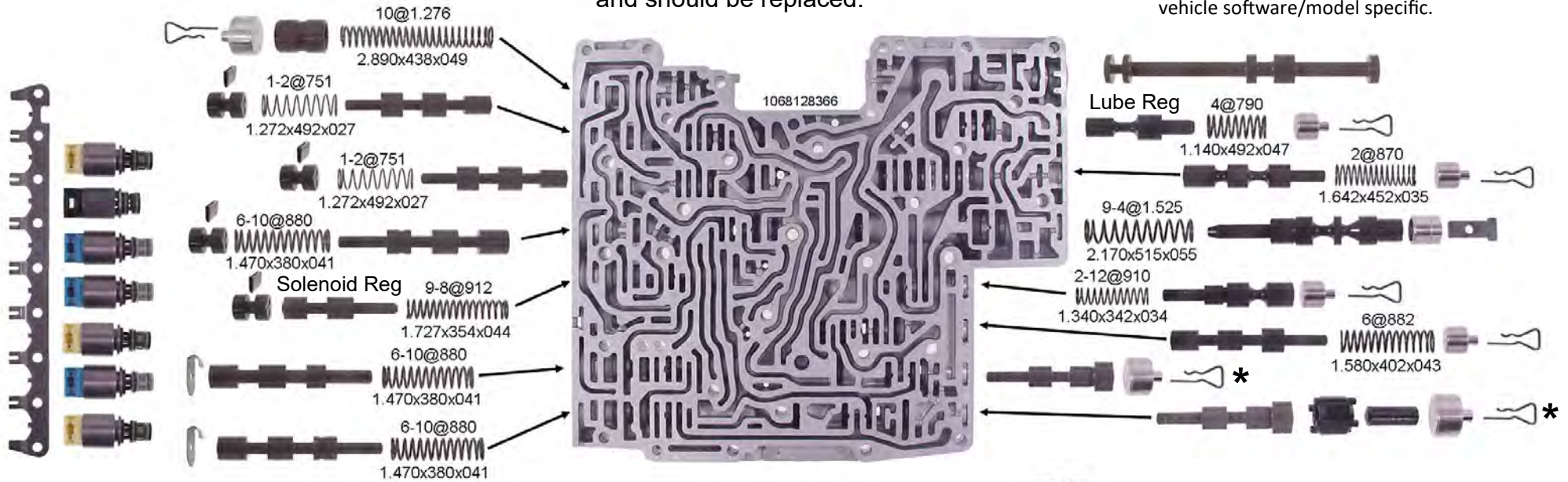
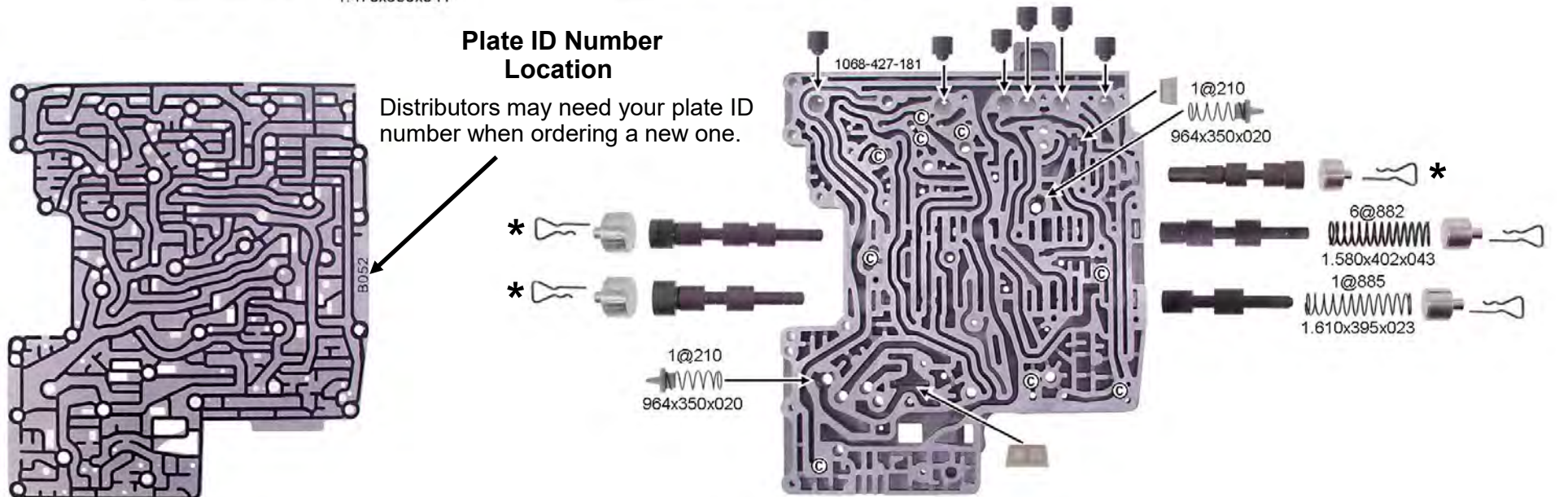

Plate ID Number Location

Distributors may need your plate ID number when ordering a new one.



ZF Additional Information

Typical E-Shift Valve Body Layout

Mark locations of ALL small parts and re-install as you found them. They are model specific.

Tech Tip: High mileage vehicles often have discolored/overheated Solenoids and should be replaced.

