



HOLD IT! Identify the valve body first!

For RE4FO3 (Small Case) VB's See other side.

ONLY use kit that matches VB! No Exceptions!

RE4FO4 A&V models: The internal solenoid wires extend outside of the case as shown below.
 Use **SK® RE4FO4A**
 For Hot Rods Only:
 Use **RE4FO4A HD-2 Reprogramming Kit®**

RE4FO4 B models: The internal solenoid wiring harness **DOES NOT** extend outside of the case!
 Use **SK® RE4FO4B**
 For Hot Rods Only:
 Use **RE4FO4B HD-2 Reprogramming Kit®**

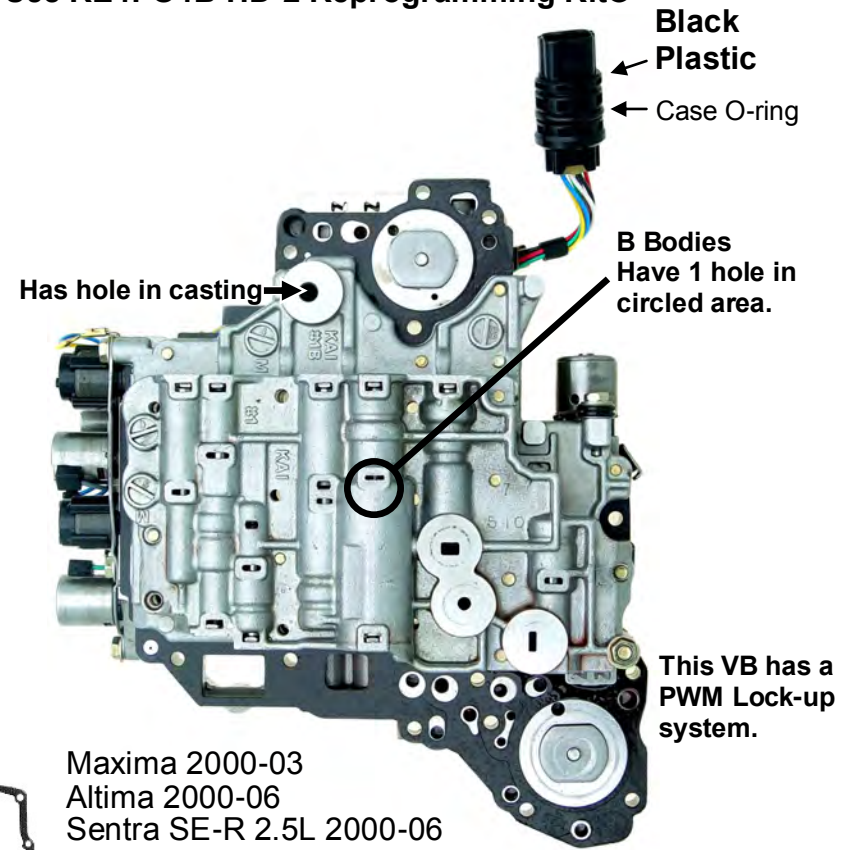
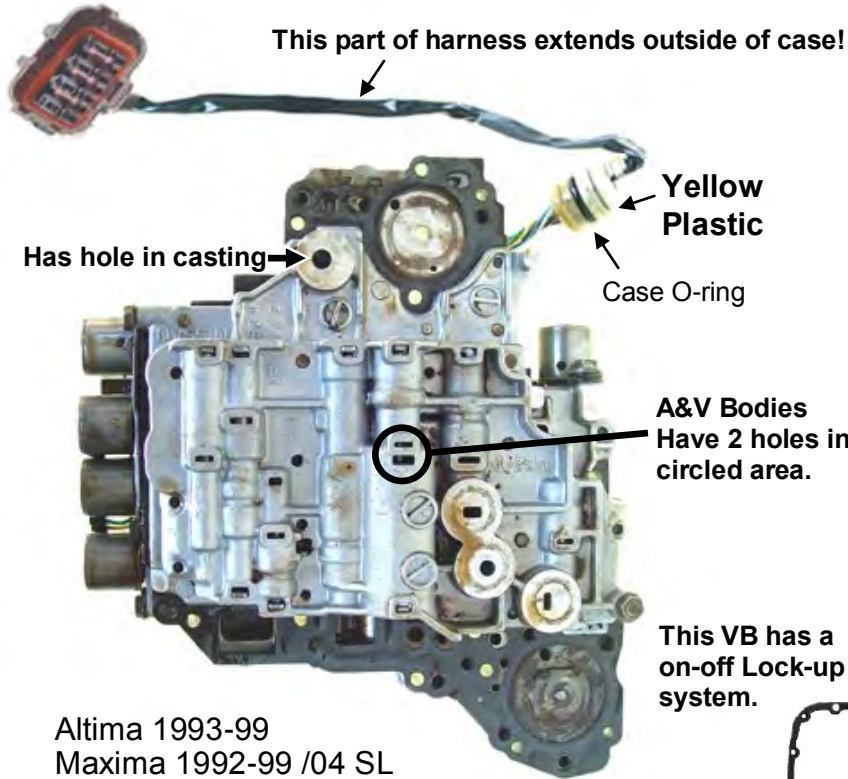

- Altima 1993-99
- Maxima 1992-99 /04 SL
- Quest 1993-02 /04 S&SL /05-06 S
- Infiniti i30 1995-99
- Mercury Villager 1993-02

- Maxima 2000-03
- Altima 2000-06
- Sentra SE-R 2.5L 2000-06
- Infiniti i30 2000-01
- Infiniti i35 2002

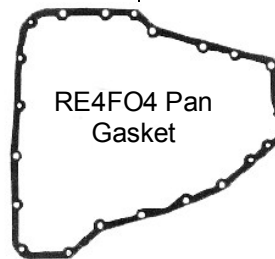

Over



HOLD IT! Identify the valve body first!

For RE4FO4 (Large Case) VB's See other side.

ONLY use kit that matches VB! No Exceptions!

RE4FO3 A models: The internal solenoid wires extend outside of the case as shown below.

Use **SK® RE4FO3A**

For Hot Rods Only:

Use **RE4FO3A HD-2 Reprogramming Kit®**

RE4FO3 B models: The internal solenoid wiring harness **DOES NOT** extend outside of the case!

Use **SK® RE4FO3B**

For Hot Rods Only:

Use **RE4FO3B HD-2 Reprogramming Kit®**

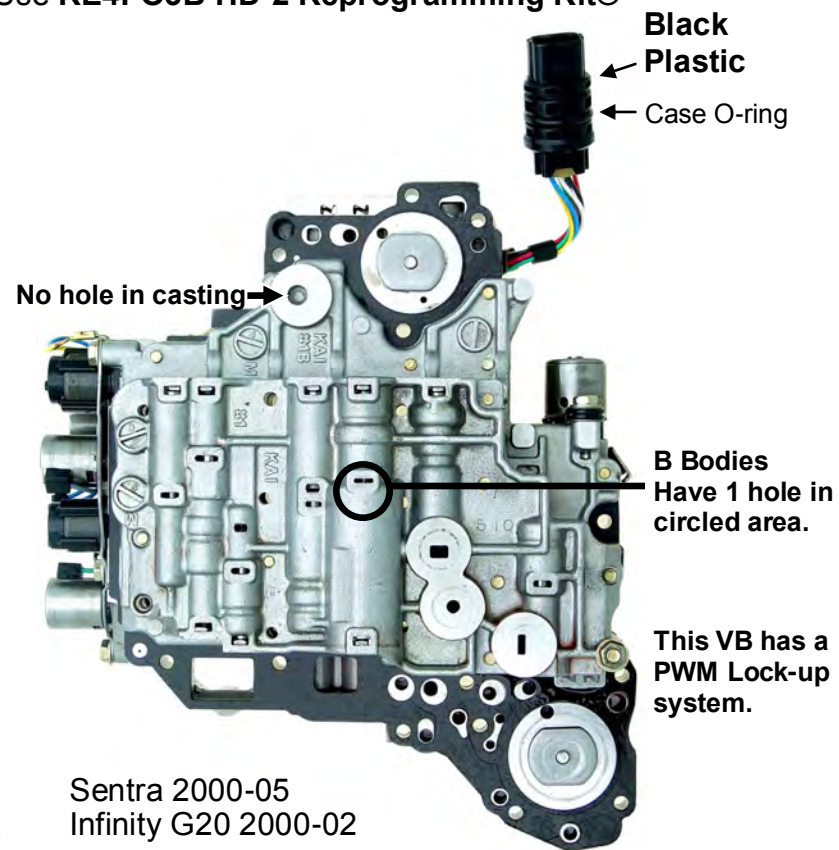
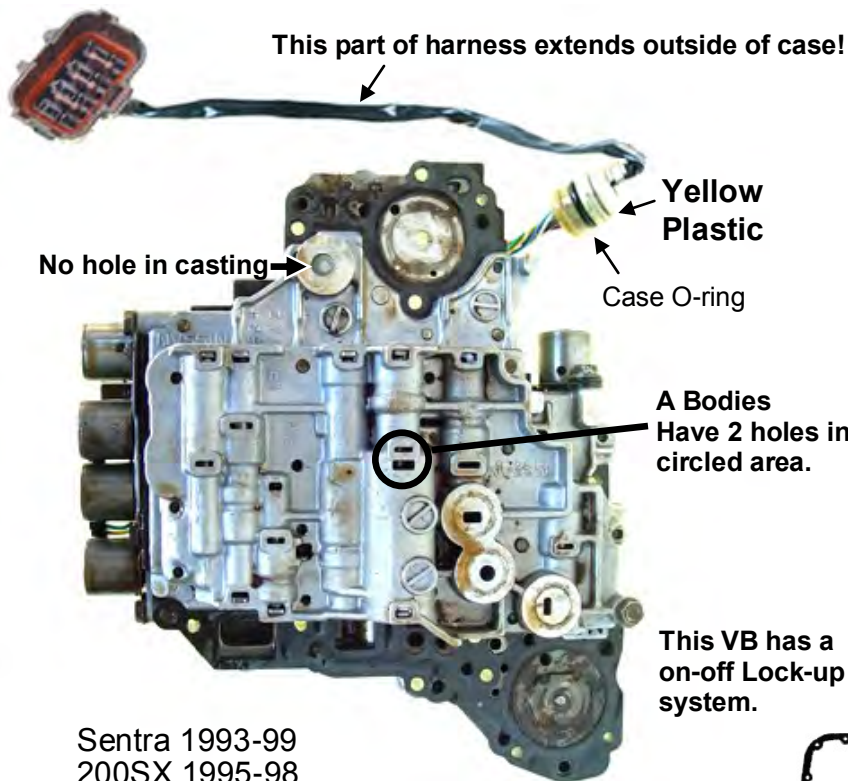

SK® RE4F04A and V models

NISSAN Maxima-Altima 92-99 & Maxima SL 04 Quest 92-02
MERCURY Villager 4F2OE 93-02 Infinity i30 95-99



Corrects/Prevents/Reduces

Falls out of gear at a stop HOT, No 3rd after a 3-2 or 4-2 kickdown, Direct clutch (3rd) inner seal **leaks**, wears or opens up due to rotating force. Corrects Hard and Soft 1-2 and 2-3

Good News! Prevents Clutch Drum Blowout and Planet failures caused by Run-away line pressure.

Step 1. Remove 1-2 Regulator valve. Chamfer partition as shown at bottom of page. Clean the bore. Reinstall valve. Install the **WHITE** spring, end plug and retainer.

Here's Why: Edge **A** on the valve hits partition at **C**. This deforms the bore which sticks the valve at land **B**.

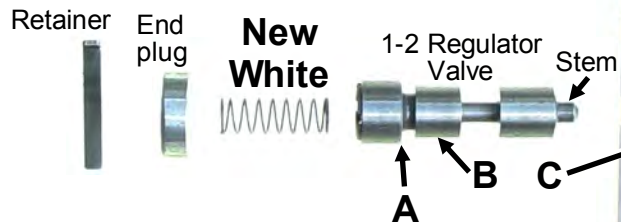

By HAND, make a slight chamfer in valve bore at "C" using a **sharp** 7/16" or 15/32" drill.

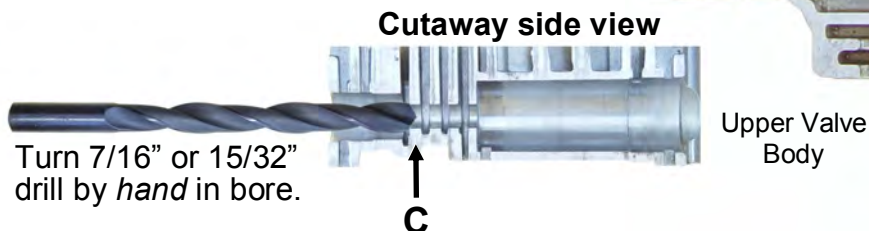

Warning: No Ball Here.

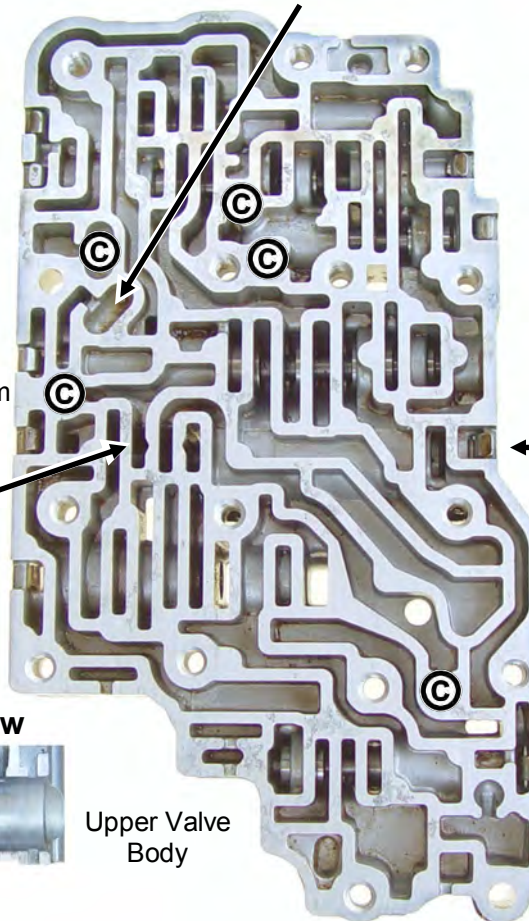

LISTEN UP:
If Trans is out of the vehicle, do Page 5 first.

Step 2. 2nd Accum Piston. Install **NEW PLAIN** spring furnished.

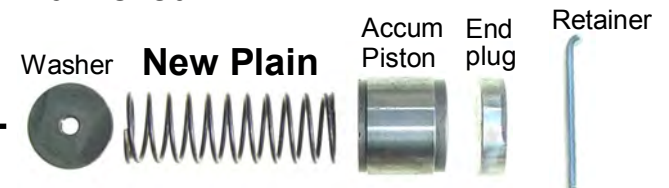

Install 1-2 regulator valve **first**. Now install the flat washer on the stem of regulator valve, then install **NEW Plain** Spring, piston, end plug then retainer.

Checkballs:

Five Steel 7/32" [.214 to .218]
Don't use plastic balls.
Use assembly gel to keep the checkballs in place **NOT** grease.



Enlarge the limit drain holes with a 1/4" drill.

1. Discard original balls and springs. Enlarge limit drain holes with a 1/4" drill. Install two **ORANGE** springs and .265 **GOLD** steel balls.

GOLD balls
.265 diam

ORANGE

2. If your plate does **not** have hole "L" (See page 3, Step 1) drill a 3/64" hole thru this partition just under the X.

Type 1&2
retainers

3. Type 1, 2 & 3 Accum Shift Valve: Remove and discard original outboard spring if it had any. Install **ORANGE** spring furnished.
Type 4 Has Empty bore. No changes.

Replace EPC Solenoid on overhaul or repair. Orange Spring prevents end plug movement that can cause pressure problems!

Type 1 & 2 Accum Shift Valve have **TWO** retainers. Misplaced retainers, valve, spring or plug can cause **Total Trans BURNUP**.

LISTEN UP:

If VB has **Type 1** valve, channel casting must use **Ball "X"** (Channel casting **Page 4**)

Types 2, 3 & 4 do not install Ball "X"

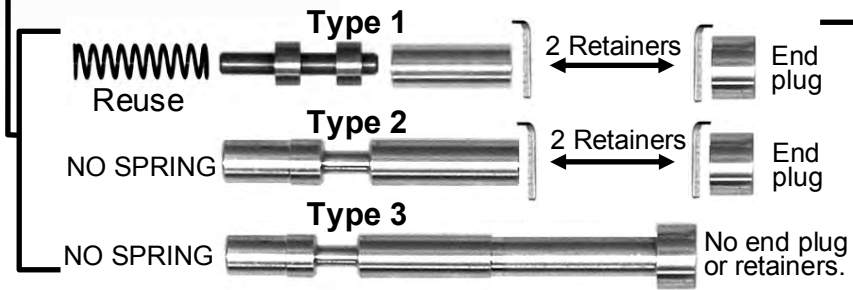

Type 4 Has empty bore, no valve, springs or retainers. Make no changes install solenoid.



EPC



Main Separator Plate

Drills Furnished in Kit:

.046

.086

Step 1

If your plate has hole "L", enlarge it with .046 drill and skip **Step 2** on page 2.

If your plate does NOT have hole "L", do NOT drill a new hole just do Step 3 on page 2.

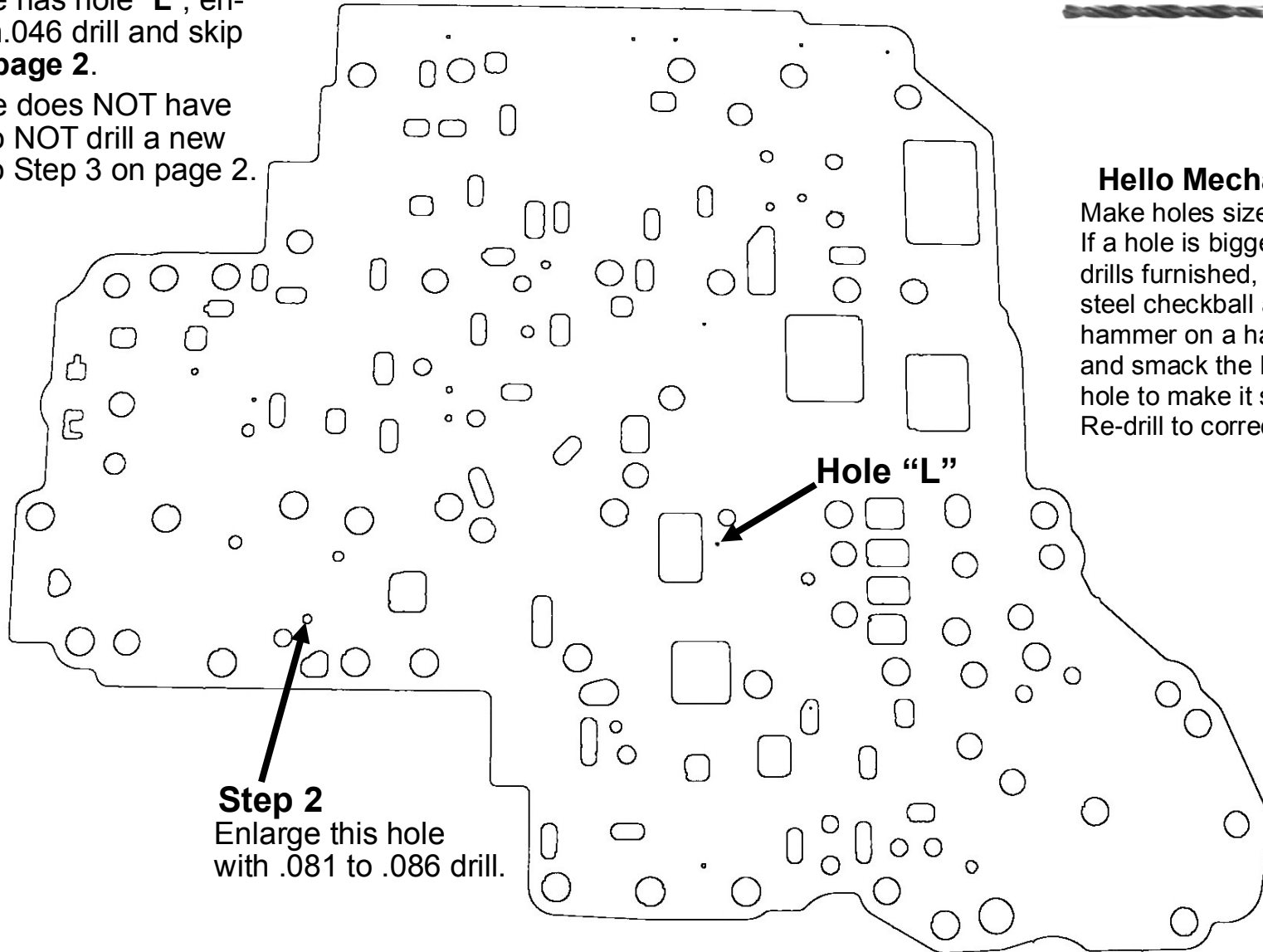

Hello Mechanic!

Make holes sizes shown. If a hole is bigger than the drills furnished, use a steel checkball and a light hammer on a hard surface and smack the ball on the hole to make it smaller. Re-drill to correct size.

Checkballs: Steel .214 to .218 Don't use plastic balls.

© All models

ⓧ Model specific see **Page 2** for proper usage.

Use assembly gel to keep checkballs in place **NOT** grease.

Channel Casting

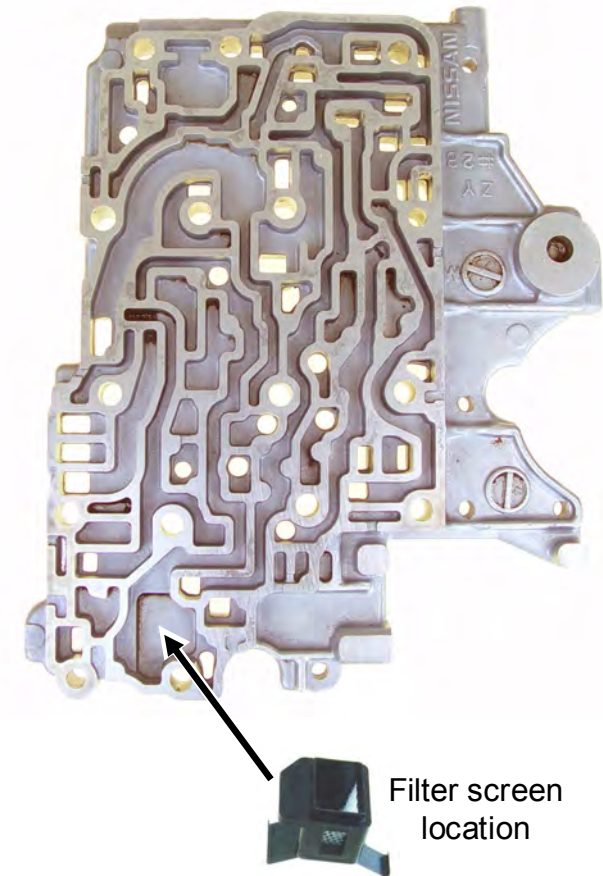
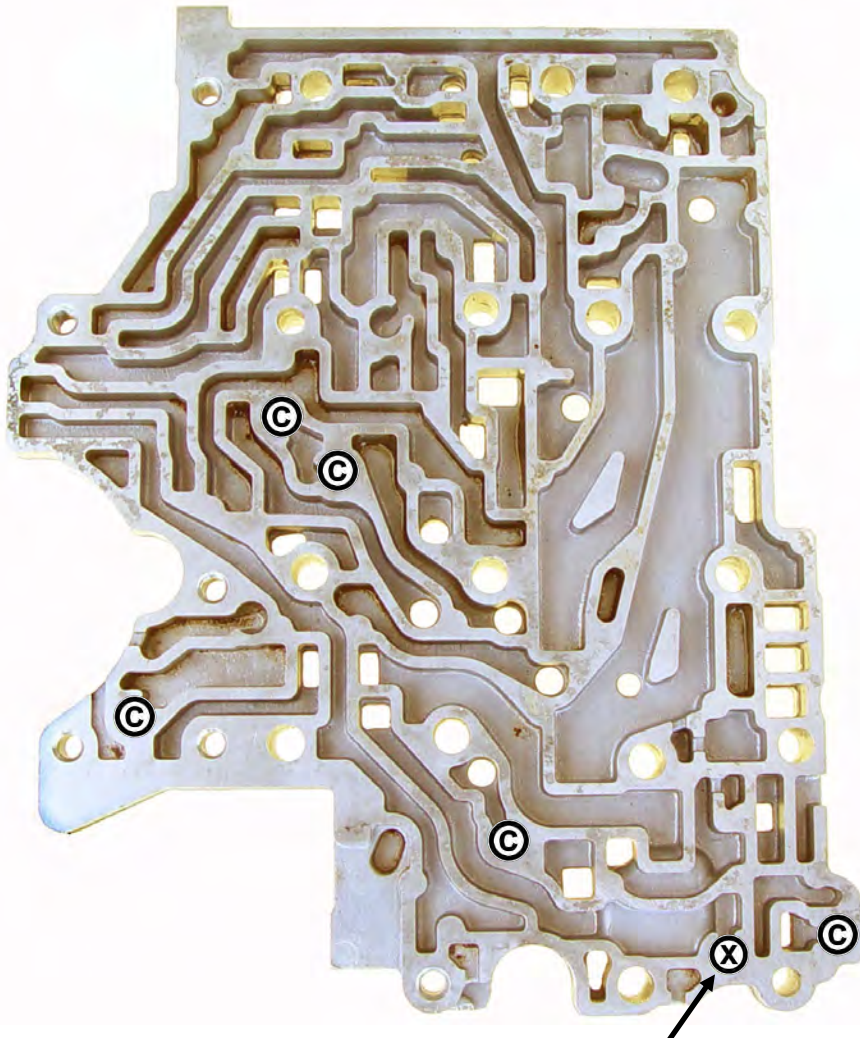

Type 1 Accum shift valve - **Must install** this ball.
Type 2, 3 & 4 Accum shift valve - Do not use this ball.
See Page 2 for accum shift valve Identification.

Fluid Level: In cold weather the Factory fluid level is too low.
Hot fluid level should be about 1/4" to 3/8" above full mark.

"Thanks for listening" Gil

Air checking Plastic Rings:

- 1) Put 20 squirts of oil into feed hole in case.
- 2) Apply clutch with full shop air and hold it for 20 seconds. Clutch **MUST** apply. If it does not, try rotating the drum or input and output shaft, add 10 more squirts and retry.
- 3) Reduce pressure to 40 psi and give the feed hole another 20 squirts. Clutch **MUST** apply.

1. Forward & Lube Rings

Use Trans Jel and **GENTLY** push rings down into grooves. Ends of rings should just touch or have small gap. If pushed together **FIRMLY** they **BIND** in groove & **WON'T SEAL**.

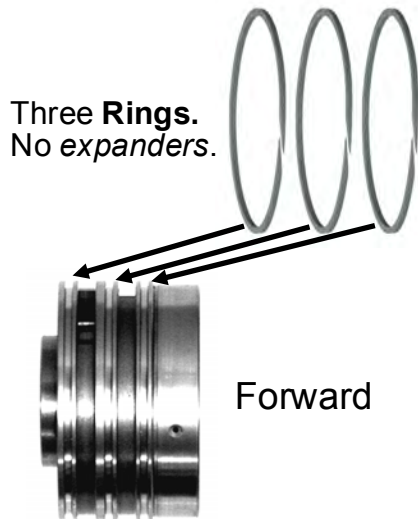

3. Third Clutch (Direct) Inner Piston Seal

Insert overlap part of **Wire** into groove at 6 O'clock. Then shape the **Seal** as shown and install into the piston groove.

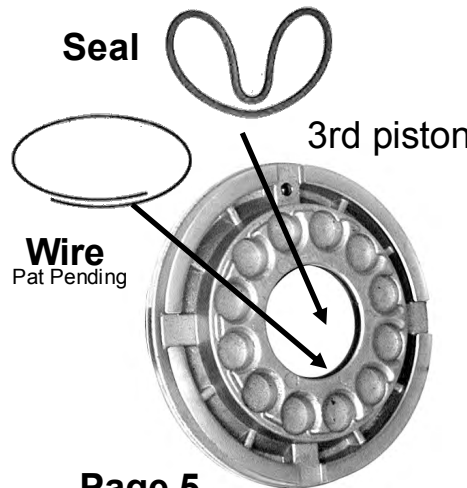

Hi-Temp Low-Shrink Rings

If trans is in vehicle skip this page.

2. Reverse Rings

Fill grooves with Trans Jel or Vaseline. Install **Expander Wires**, then two **Rings**.

LISTEN UP:

Some models have shallow grooves. Rings **MUST** push **flush** into the grooves. **If rings wont push flush don't use wire.**

Expander Wires

Pat Pending

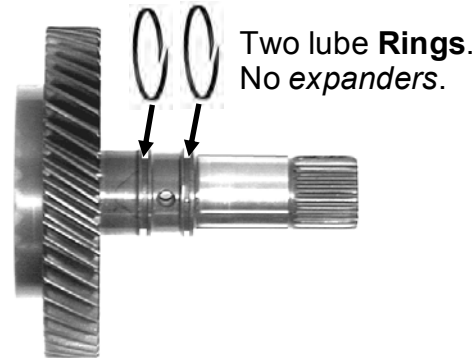
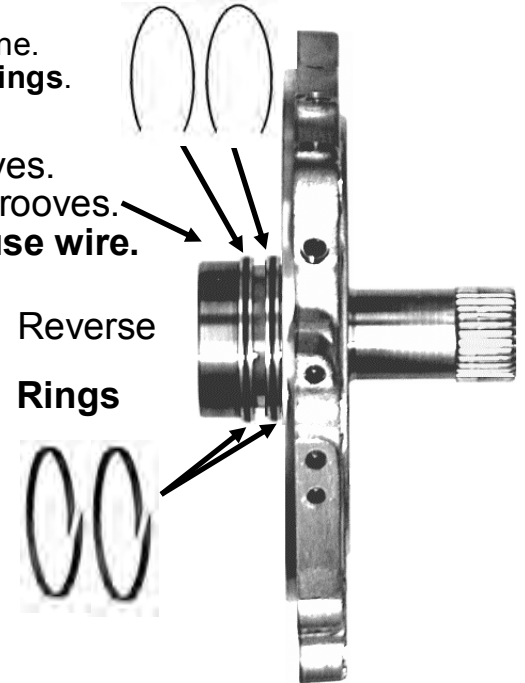

4. Third Clutch Drum Rings

Fill the grooves with Trans Jel or Vaseline. Install **Expander Wires**, then three **Rings**.

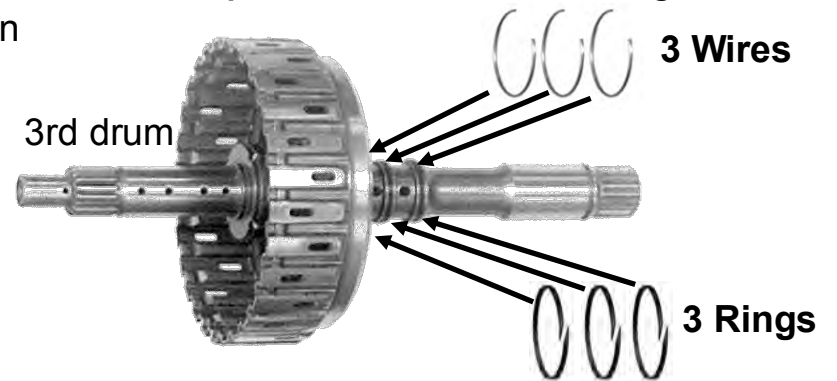

Additional Information

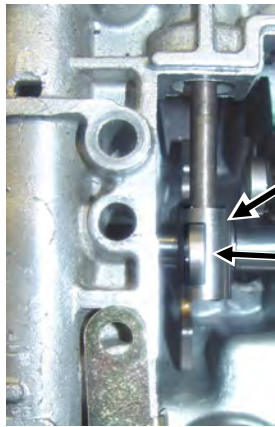

Align manual valve as shown.

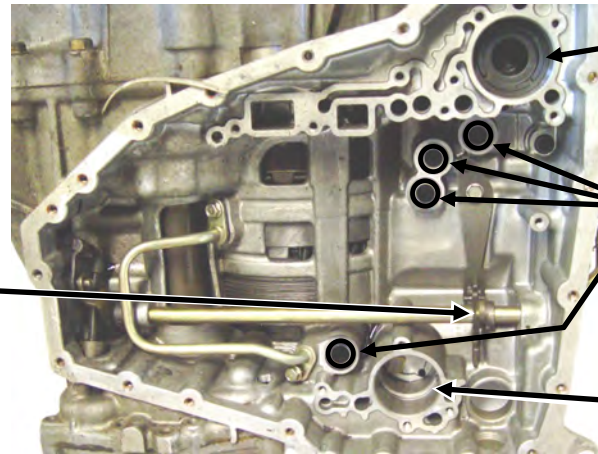

This accum piston installs into case first then spring.

Make sure 4 rubber o-rings are in place before installing the VB.

This accum piston installs with spring in case first then piston.



Check Band Adjustment:

If band will wiggle on drum 1/16" by hand, you can skip the band adjustment.

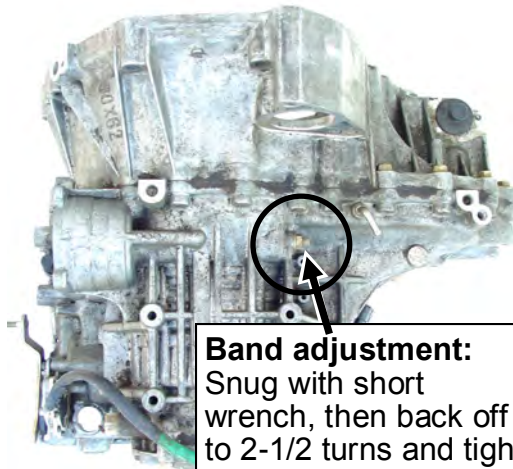

Band adjustment:
Snug with short wrench, then back off 2 to 2-1/2 turns and tighten lock nut.
Use 14mm wrench and T30 TORX bit.

You must be able to wiggle band back and forth at least 1/16" .

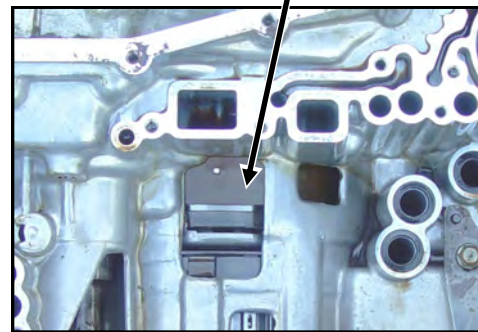
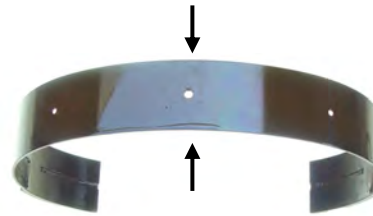

Mr. Shift®

A bit of advice from someone who's been there... These tran's love a new EPC Solenoid. Don't try to save a buck and use it over. They get in trouble around 70,000 miles. Your success is important to us!