

# Drawbar trailer Air Brake and Suspension System with TEBS G2.2 Premium (4S/3M brake system with TEPM-P, air suspension system with 2 raise/lower valves and TIM G2)

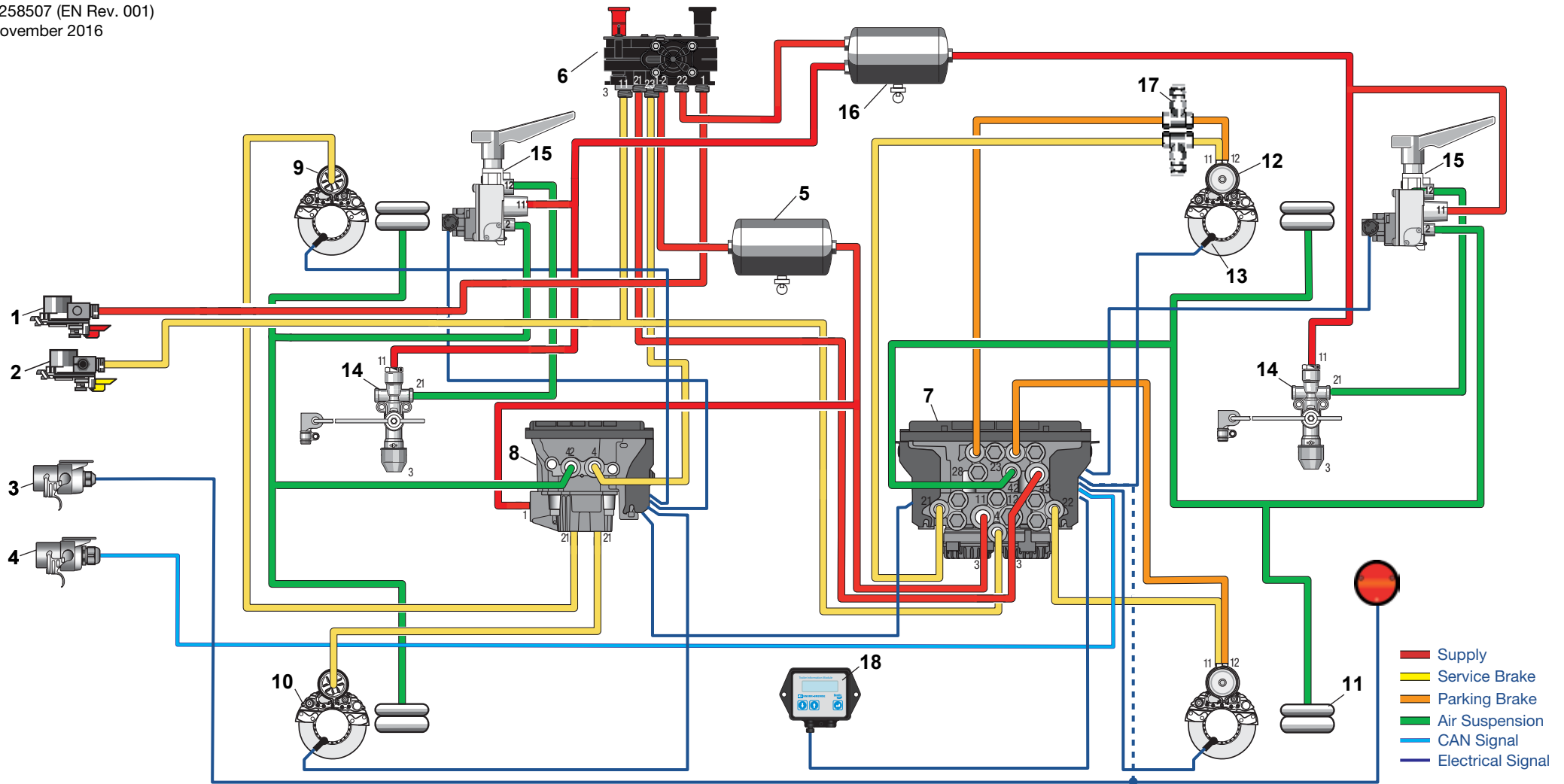

Y258507 (EN Rev. 001)  
November 2016



- 1 Coupling Head "Supply" with Filter
- 2 Coupling Head "Control" with Filter and Test Connector
- 3 ISO 12098 Connector
- 4 ISO 7638 Connector (EBS)
- 5 Air Reservoir (Service and Parking)

- 6 Park/Shunt Valve with integrated Charging Valve and Front Axle Release Valve
- 7 TEBS G2.2 Brake Module - Premium
- 8 Trailer Electro-Pneumatic Module - Premium (TEPM-P)
- 9 Brake Chamber

- 10 Air Disc Brake
- 11 Air Suspension Bellows
- 12 Spring Brake
- 13 Sensing Ring and Wheel Speed Sensor
- 14 Levelling Valve (without Height Limitation)

- 15 Raise/Lower Valve with Reset-to-Ride Height
- 16 Air Reservoir (Air Suspension)
- 17 Test Connector
- 18 TIM G2