



# Vallox 200<sub>SE</sub>

- 1.09.393E
- 25.1.2013
- Code 3486
- © VALLOX

**Electronically controlled  
supply/extract ventilation  
with heat recovery**

**INSTRUCTIONS FOR USE AND MAINTENANCE**



**DIGIT SED**  
ELECTRONIC CONTROLLER  
WITH LCD DISPLAY





# VALLOX 200 SE

## TABLE OF CONTENTS

### EVERYDAY QUICK GUIDE

VALLOX 200 SE has been initially adjusted for normal circumstances in your home. Ventilation adjustment is needed mainly in the following circumstances:

**• Taking a bath:**

Boost ventilation in bathing and washing facilities in order to ensure that the rooms get dry as quickly as possible. It is advisable to have boosted ventilation on for 2 to 3 hours after taking a sauna bath, unless there is an automatic adjustment based on humidity content.



**• Washing and drying clothes:**

Boost ventilation in washing and drying rooms during the activity, unless there is an automatic adjustment based on humidity content.

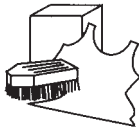

**• Sleeping:**

Ventilation in a bedroom has to be sufficient throughout the night. The level is correct when air does not smell musty when you enter the room in the morning. If the carbon dioxide content of a room is monitored and ventilation is adjusted accordingly, air will always be fresh.



**• Empty dwelling:**

To save energy, ventilation can be adjusted to the minimum level.



**• Cooking:**

If the ventilation unit is connected to a cooker hood, boost ventilation during cooking.

**The most common way to abate cooking fumes is to have a separate cooker hood.**



**NOTE!**

**Never switch ventilation off because ventilation keeps indoor air quality uniform and removes gases and dust emanating from the structures.**

### VALLOX 200 SE

Code: 3486

Letter L or R after the name of the unit indicates whether the unit is left- or right-handed.

#### 1. THREE QUESTIONS ABOUT VENTILATION

- 1.1. Why is air replaced in dwellings? ..... p. 3
- 1.2. What are the characteristics of adequate ventilation? ..... p. 3
- 1.3. How much air is replaced? ..... p. 3

#### 2. INSTRUCTIONS FOR USING VALLOX 200 SE

- 2.1. Making the unit ready for operation ..... p. 4
- 2.2. Ventilation control ..... p. 4
- 2.3. Ventilation control with control panel ..... p. 4
- 2.4. Ventilation control with carbon dioxide sensor ..... p. 5
- 2.5. Ventilation control with humidity sensor ..... p. 5
- 2.6. Ventilation control with voltage signal ..... p. 6
- 2.7. Ventilation control with remote monitoring system ..... p. 6
- 2.8. Post-heating ..... p. 6
- 2.9. Supply air constant temperature control ..... p. 6
- 2.10. Supply air cascade control ..... p. 6
- 2.11. Heat recovery bypass function ..... p. 7
- 2.12. Antifrost function of heat recovery cell ..... p. 7
- 2.13. Antifreeze function in a water-circulating post-heating unit ..... p. 7
- 2.14. Maintenance reminder ..... p. 7
- 2.15. Filter guard function ..... p. 7
- 2.16. Fireplace/booster switch ..... p. 8
- 2.17. Fault signal relay ..... p. 8
- 2.18. Air filtering ..... p. 8

#### 3. CONTROL PANEL

- 3.1. Instructions for use ..... p. 9
- 3.2. Operating menu ..... p. 9
- 3.3. Settings menu ..... p. 10
- 3.4. Week clock control ..... p. 12
- 3.5. Factory settings ..... p. 12

#### 4. MAINTENANCE INSTRUCTIONS

- 4.1. Filters ..... p. 13
- 4.2. Fans ..... p. 13
- 4.3. Filter guard ..... p. 14
- 4.5. Condensing water ..... p. 14

#### 5. TROUBLESHOOTING ..... p. 15

*This appliance can be used by children aged from 8 years and above and persons with reduced physical, sensory or mental capabilities or lack of experience and knowledge if they have been given supervision or instruction concerning use of the appliance in a safe way and understand the hazards involved.*

*Children shall not play with the appliance.*

*Cleaning and user maintenance shall not be made by children without supervision.*

## THREE QUESTIONS ABOUT VENTILATION

### 1. THREE QUESTIONS ABOUT VENTILATION

#### 1.1. Why is air replaced in dwellings?

**Good ventilation promotes healthy living for both residents and the building.** Air in a dwelling needs to be replaced in order to remove humidity brought about by living as well as impurities emanating from structures and human bodies. Impurities of indoor air include carbon dioxide, formaldehyde, radon and other gases as well as dust.

Mechanical ventilation is needed in order to be able to adjust air circulation as needed by the residents. In a tightly sealed house, air does not circulate sufficiently by natural means. Even in a poorly sealed house air is only replaced because of differences between indoor and outdoor air temperatures, or because of winds. This means that ventilation is dependent on weather conditions and cannot be regulated.

It is especially important that humidity and carbon dioxide content of indoor air stay at a healthy level. Recommended humidity content of good indoor air is approximately 45%. Humidity content is lower in winter and higher in summer and autumn. Dust mites thrive in indoor air if humidity exceeds 50%, and if humidity stays at over 60% for a long time in winter, water will condense in the cold structures of the house and mould will start to form. The recommended maximum carbon dioxide content in good indoor air is circa 1,000 ppm.

#### 1.2. What are the characteristics of adequate ventilation?

- Indoor air stays fresh in all the rooms of the dwelling, also in bedrooms during night. **Without adequate ventilation** carbon dioxide content tends to rise high especially in bedrooms.
- The bathroom and the sauna get dry quickly.
- During the heating season, the windows and other outer wall structures remain dry.
- Humidity in indoor air is not condensed in the ventilation ducts.
- Air is fresh in the toilet as well.

#### 1.3. How much air is replaced?

For air to be clean to breathe, **it has to be replaced with outdoor air once in two hours.**

In a new and a renovated house, air needs to be circulated continually, at least once an hour, during the first year in order to remove harmful gases and structural humidity from the structures. In buildings that are more than a year old and dry, ventilation can be regulated as needed. Ventilation is boosted during for instance a sauna bath, clothes washing and cooking, and reduced during very cold periods or when there is nobody at home. Carbon dioxide and humidity sensors adjust ventilation in the rooms automatically as needed.

### SEASONAL CALENDAR

#### Autumn

- Wash or change the coarse filter and clean or change the fine filter if needed.
- Check that the heat recovery cell is clean.
- Check that the condensing water outlet is not clogged.
- Switch the post-heating radiator on.



#### Spring

- Wash or change the coarse filter and clean or change the fine filter if needed.
- Clean the fan blades and the post-heating unit if needed.
- Check that summer ventilation is in operation.
- Switch the post-heating radiator off.



#### NOTE!

For further details, see inner pages.



# VALLOX 200 SE

## INSTRUCTIONS FOR USE

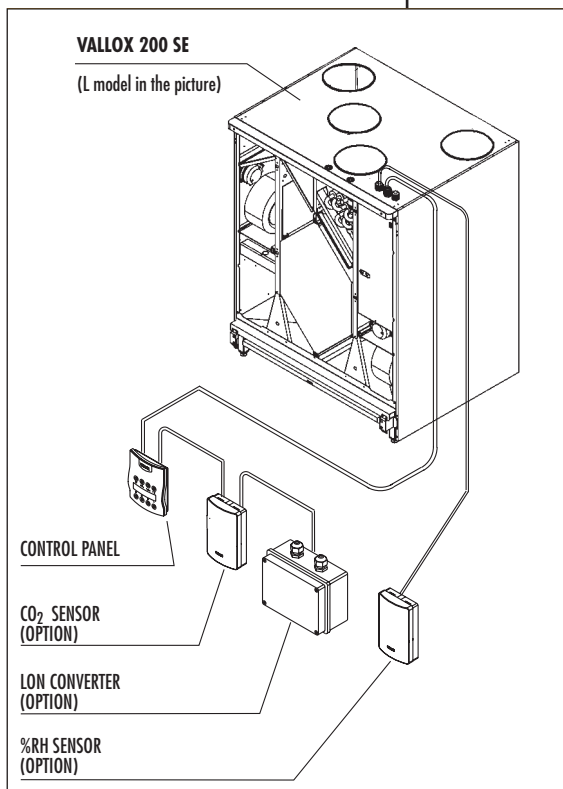

## 2. Instructions for using VALLOX 200 SE

For indoor air to stay healthy and beneficial also for the structures of the dwelling, ventilation has to be in operation continuously. It is not advisable to stop ventilation even for longer holidays because it makes indoor air stuffy. Also, during the heating season indoor air humidity may condense in the ducts and structures and therefore cause humidity damage. The sensors automatically adjust ventilation to an optimal level even if the dwelling is empty.

### 2.1. Making the unit ready for operation

1. After VALLOX 200 SE has been connected permanently to the mains supply and the control panel to the unit, it is ready for operation.
2. Turn the unit on and choose a suitable ventilation power at the control panel. There is either one or more control panels. See the instructions for using the control panel in Section 3.2.1.

In normal conditions **basic ventilation**, with a change of air every two hours, is sufficient in living areas. Boosting is needed during for example sauna baths, cooking, clothes washing or family parties. If carbon dioxide and/or humidity sensors have been installed in the system, VALLOX 200 SE also takes care of demand controlled ventilation.

### 2.2. Ventilation control

The unit can be fully controlled with the control panel delivered with the unit or with an optional LON converter.

The standard week clock control can be used to control the fan power of the unit and the setpoint for supply air temperature.

Furthermore, demand controlled ventilation can be adjusted with optional carbon dioxide and humidity sensors.

The fan power of the unit can also be controlled with a voltage signal.

### 2.3. Ventilation control with control panel

The control panel can be used for the following ventilation control functions:

#### 2.3.1. Functions for adjusting ventilation power

- Starting and stopping.
- Power adjustment (8 positions).
- Setting the base fan speed and the maximum fan speed. Ventilation power cannot be set lower than the base fan speed. When carbon dioxide and/or relative humidity adjustments are activated, power cannot be adjusted higher than the set maximum fan speed. When humidity and carbon dioxide adjustments are switched off, fan speed can be raised to position 8 (factory setting). Maximum fan speed limitation can be selected at the settings menu to be in operation permanently (see the instructions for using the control panel, Section 3.3.6.).

#### 2.3.2. Supply air temperature adjustment functions (post-heating radiator is optional)

- Switching the electric post-heating unit on/off.
- Setting the desired supply air temperature (+10 °C...+30 °C).
- Selecting the method for controlling the desired supply air temperature (constant temperature control, cascade control of temperature).

#### 2.3.3. Electric preheating (the preheating unit is optional)

- Setting the control temperature for the preheating unit (-6 °C...+15 °C exhaust air).
- Changing the setpoints.

There may be three control panels at most. When more than one control panel are used, the most recent control function is valid.



**DIGIT SED**  
ELECTRONIC CONTROLLER  
WITH LCD DISPLAY

### 2.3.4. Liquid-circulating preheating and cooling (MLV unit is optional)

- Setting the control temperature for the heating function in the liquid-circulating MLV unit (-6 °C... + 15 °C, outdoor air). The function is on when outdoor air temperature goes below the set temperature and post-heating has been switched on (see the instructions for using the control panel, Section 3.3.24.).
- The temperature value must be lower than the temperature of the liquid coming from the ground collector, then the liquid heats outdoor air. If preheating cannot keep exhaust air temperature warmer than the stopping temperature, the outdoor air fan stops.
- Setting the control temperature for the cooling function in the liquid-circulating MLV unit (+10 °C...+30 °C, supply air). The cooling function starts when the post-heating radiator has been switched off and the temperature of air coming from the unit to the dwelling exceeds the setpoint temperature of supply air (see the instructions for using the control panel, Section 3.2.6.). When choosing the setpoint temperature for supply air, care must be taken so as not to bring too cold air into the duct, which may cause humidity damage. The risk is small when the ground collectors of the heat pump are situated in the ground or in a water system and the liquid received from them is warmer in summer than the liquid circulating in a drilled well.

If the duct is not insulated against condensation indoors, the temperature of air travelling in it must be confined to below the dew point, which depends on the ambient temperature and relative humidity. In hot weather, supply air temperature should not go below +16 °C ...+20 °C.

### 2.4. Ventilation control with carbon dioxide sensor (option)

- In carbon dioxide control, VALLOX 200 SE adjusts fan speed so as to keep carbon dioxide content in the ventilation zone below the setpoint. When two or more sensors are used, fan speed is adjusted according to the highest measuring result.
- 1 to 5 carbon dioxide sensors can be connected as options to the VALLOX 200 SE unit.
- The adjustment is switched on/off and, if needed, the setpoint (500...2000 ppm) is set at the control panel. The factory setting is 900 ppm. The recommended maximum carbon dioxide content in good indoor air is 1,000 ppm.
- When carbon dioxide control is on, the control panel may be used to raise fan speed to the maximum fan speed and to decrease it to the base fan speed. In carbon dioxide control, maximum fan speed limitation is enabled.

### 2.5. Ventilation control with humidity sensor (option)

There are two methods for adjusting fan speed.

- 1 **Automatic humidity setting**, which is suitable for controlling humidity in washing rooms, for instance. The program records current humidity level and selects it as the setpoint, which it then uses as the target for drying air in a bathroom e.g. after a shower. The setpoint automatically varies according to season, for instance, and is always at the right level. This setting is factory selected.
- 2 Humidity level can also be set **fixed**. The setting can range between 1 and 99 %RH and is set at the control panel. This can be used in public saunas and swimming pools, for instance. The program aims at keeping humidity at the setpoint. The setpoint can be changed if needed.

The mode of adjusting is chosen at the controller. Recommended humidity content of good indoor air is approximately 45%.

- When this control is on, the control panel may be used to raise fan speed to the maximum fan speed and to decrease it to the base fan speed.
- In humidity control, fan speed varies between the base and maximum fan speeds selected.
- When the unit is first taken into use **with automatic setpoint search enabled** (factory setting), **it takes 3 to 10 hours for the program to define the value**. During this time, humidity adjustment is not enabled (because the first value, selected at the factory, is 100%).
- Automatic search is enabled even if humidity control is not selected.



Carbon dioxide sensor (CO<sub>2</sub>)



Humidity sensor (RH)



LON converter



## INSTRUCTIONS FOR USE

### 2.6. Ventilation control with voltage signal

- VALLOX 200 SE fan power can be controlled with a voltage signal coming from remote monitoring.
- The signal can be used to select speeds 0–8. However, the set maximum fan speed cannot be exceeded if carbon dioxide or humidity adjustment is active, or if maximum fan speed limitation has been selected in the settings menu to be in operation all the time (see the instructions for using the control panel in Section 3.3.6.).
- The signal changes the base fan speed.
- The signal does not lock fan speed, i.e. fan speed can be changed at the control panel within the set limits. Carbon dioxide and humidity adjustment also operate within the set limits.

### 2.7. Ventilation control with remote monitoring system (option)

- With an optional LON converter, VALLOX 200 SE can be connected to a remote monitoring system.
- When VALLOX 200 SE is connected to the remote monitoring system, compatibility between the two needs to be ensured.
- The remote monitoring system can control the same functions as the control panel does.
- The remote monitoring system works in parallel with the control panel and with carbon dioxide and humidity sensors.

### 2.8. Post-heating (option)

For most of the year, heat recovered from the air being extracted is enough to warm the cold air coming from the outside to a suitable temperature. If the heat of extract air is not enough, air coming from the outside may be heated further, as needed, with the radiator delivered with the unit.

The post-heating radiator may be electric or water-circulating. Heating can in both cases be activated at the control panel (see the instructions for using the control panel in Section 3.1.). When heating has been activated, the unit automatically adjusts the temperature selected.

### 2.9. Supply air constant temperature control

- VALLOX 200 SE has a relative post-heating control; when the temperature selected exceeds supply air temperature by more than 2.5 °C, the radiator is on 100%, and when the temperature difference gets smaller, the period of active operation is automatically reduced in two-minute sequences. The adjustment range for heating is 10...30 °C.
- The heating radiator is on when the (⊞) sign is displayed.
- Temperature control is only active when post-heating has been switched on.

### 2.10. Supply air cascade control

- Supply air temperature control can be changed into cascade control.
- It changes the controlling principle of the post-heating radiator. The temperature of air blown to the ventilation zone is controlled on the basis of extract air.
- The program tries to keep supply air temperature at a value determined by the difference between extract air and the setpoint as follows: If extract air is warmer than the setpoint, supply air temperature is lower than the setpoint by the difference. If extract air is colder, supply air is higher than the setpoint by the difference.  
If the temperature in the ventilation zone is 25 °C and the setpoint is 24 °C, the aim is to blow 23 °C air to the ventilation zone. If the temperature in the ventilation zone is 24 °C and the setpoint is 25 °C, the aim is to blow 26 °C air to the ventilation zone.
- The aim is to keep the temperature of air blown to the ventilation zone always within the range of 10...30 °C.
- Cascade control can be selected at the control panel, and it is active when post-heating has been switched on.
- The heating radiator is on when the (⊞) sign is displayed.

2.8.



#### Remember!

Switch post-heating off when it starts to get too warm in the dwelling because of warm weathers.

Switch post-heating on again when it gets cooler in autumn.



### 2.11. Heat recovery bypass function

- The bypass function tries to get as cool supply air as possible to the ventilation zone by comparing the measuring results of the outdoor air and extract air sensors.
- The heat recovery cell is bypassed when post-heating is switched off, outdoor air temperature is two degrees more than the setpoint and extract air is warmer than outdoor air.
- The setpoint can be changed between 0 and +25 °C (Factory setting 12 °C).

### 2.12. Heat recovery antifrost function and preheating

- Antifrost prevents the heat recovery cell from freezing, thus ensuring proper ventilation even in cold periods.
- Antifrost is implemented by stopping the supply air fan. The stopping function is controlled on the basis of the measurement data given by the temperature sensor that measures the temperature of exhaust air after the heat recovery cell.
- The supply air fan stops when exhaust air temperature falls to the setpoint (factory setting +6 °C) and starts when exhaust air temperature has risen to the value set (by the amount of the hysteresis setting, factory setting +3 °C).

#### Preheating

- The unit can be equipped with either an electric or liquid-circulating preheating radiator. The purpose of using the radiator is to minimise momentary stopping of the supply air fan. This ensures a maximally even supply air flow through the unit.
- The preheating radiator switches on when exhaust air temperature falls to the setpoint (factory setting +8 °C) and switches off when exhaust air temperature has risen to the value set (by the amount of the hysteresis setting, factory setting +3 °C).
- In order to ensure the operation of the preheating radiator, the setpoint of exhaust air temperature must be higher than that of supply air fan stopping temperature.
- The liquid-circulating preheating radiator (MLV unit) starts when post-heating has been switched on and outdoor air temperature is below the preheating setpoint (factory setting +6 °C). The setpoint must be lower than the temperature of the liquid coming from the ground collector.

### 2.13. Antifreeze function in a water-circulating post-heating unit

- The antifreeze function aims at preventing a water-circulating post-heating unit from freezing. The automatic function stops the supply and extract air fans as soon as outdoor air temperature falls below 0 °C and supply air temperature below +7 °C, in which case also the control valve becomes wide open. The control panel displays the fault message FREEZING ALERT, irrespective of display.
- The fans start automatically as soon as supply air temperature exceeds 10 °C.

### 2.14. Maintenance reminder

- The maintenance reminder switches on the maintenance reminder symbol (🔧) in the main display of the control panel at defined intervals, the factory setting being 4 months.
- The maintenance reminder symbol is reset at the control panel (see the instructions for using the control panel in Section 3.3.10.).
- The interval can be set between 1 and 15 months at the control panel.

### 2.15. Filter guard function

- If VALLOX 200 SE is equipped with a pressure difference switch for the supply and/or extract air ductwork, the switch monitors the pressure difference in the whole ductwork. When pressure has risen (e.g. because of a clogged filter), the filter guard symbol (🚫) in the main display of the control panel is lit up.
- The filter guard closes the contacts of the fault signal relay, and the filter guard symbol (🚫) is seen in the main display. The maintenance reminder is on even during this function.
- The operation threshold for the pressure difference switch is adjusted at the pressure difference switch regulator (0...500 Pa). Factory setting is ca. 260 Pa and can be changed if needed. With clean filters, the symbol should light up at speeds 7 and 8.

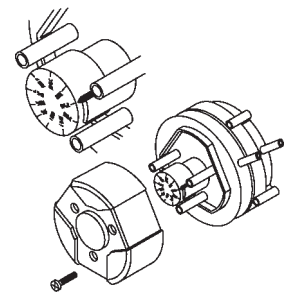

Pressure difference switch



# VALLOX 200 SE

## INSTRUCTIONS FOR USE

### 2.16. Fireplace switch function / boosting

#### Fireplace switch function

- The fireplace switch stops the extract air fan for 15 minutes and produces overpressure in the ventilation zone. This makes it easier to light the fireplace, for instance.
- The function is started at the main display of the control panel by simultaneously pressing and holding down the + and - buttons for 2 seconds.
- The function can also be started at a separate auto-reset push-button switch, wired from the connection box of the unit to a wall in the fireplace room, for instance. Upon each pressing, the stopping function continues for 15 minutes (the switch is not included in the delivery).
- During the function the fireplace/booster switch symbol (⌋) is visible in the main display of the control panel.

#### **NOTE! The starting of the extract air fan may weaken draught in the fireplace!**

**During cold winter periods, the flowing of cold air to the extract ducts may cause the antifreeze and antifrost functions to start. If the post-heating radiator does not contain non-freezing solution, there is a freezing risk. The situation will normalise in a while, after the functions stops.**

#### Booster switch function

- The booster switch raises the fan speed to the set maximum speed for 45 minutes.
- The function is started at the main display of the control panel by simultaneously pressing and holding down the + and - buttons for 2 seconds.
- The function can also be started at a separate auto-reset push-button switch, wired from the connection box of the unit to a wall in a classroom, for instance. Upon each pressing, the boosting function continues for 45 minutes (the switch is not included in the delivery).
- During the function the fireplace/booster switch symbol (⌋) is visible in the main display of the control panel.
- The function is selected at the control panel.

### 2.17. Fault signal relay (remote monitoring)

- The fault signal relay has potential-free contacts (24 VDC, 1 A).
- The contacts provide information on various failure modes of the unit.
- When the antifreeze function of the water-circulating radiator is on, the contacts of the relay close and open at 10-second intervals.
- Alarm of high carbon dioxide content switches the relay at 1-second intervals.
- In other fault situations, the contacts are closed.

### 2.18. Air filtering

VALLOX 200 SE features coarse filtering of both extract and supply air before the fans. The unit has F7 (B) and G4 class (A) fine and coarse filters on the supply side and a G4 class coarse filter (A) on the extract side. The filters need to be in place in the unit whenever ventilation is in operation.

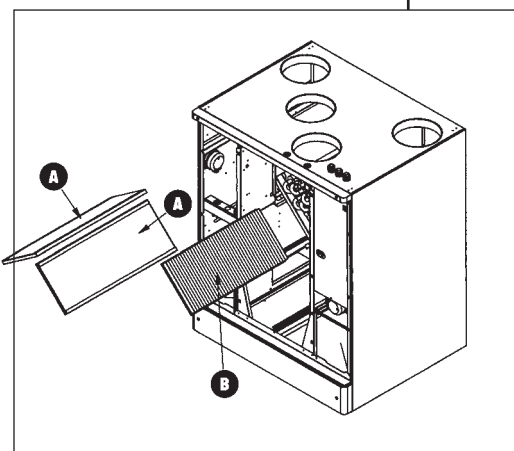



## INSTRUCTIONS FOR USING THE CONTROL PANEL

### 3. Control panel

#### 3.1. Keyboard



##### 1 Start button

Use this button for switching the unit on and off. When the indicator is lit, the unit is on.

##### 2 Carbon dioxide adjustment

Press this button to switch carbon dioxide adjustment on and off. When the indicator is lit, the adjustment is on.

##### 3 Humidity adjustment

Press this button to switch humidity adjustment on and off. When the indicator is lit, the adjustment is on.

##### 4 Post-heating

Press this button to switch post-heating on and off. When the indicator is lit, post-heating is on. The summer function is active when the indicator is not lit.

##### 5 Scrolling up

With this button you can scroll the displays upward.

##### 6 Scrolling down

With this button you can scroll the displays downward.

##### 7 Increase button

With this button you can increase values.

##### 8 Decrease button

With this button you can decrease values.

#### Power failure

**After a power failure, the unit starts at minimum fan speed. The adjustments and setpoints chosen will remain in the memory of the unit in spite of the power failure.**

#### 3.2. Operating menu

The displays of the operating menu (sections 3.2.1.–3.2.6.) can be scrolled with the scrolling buttons (see section 3.1., items 5 and 6 in the figure).

##### 3.2.1. Main display and change of fan speed



 3 Fan speed (3).

 21 °C Supply air temperature (21 °C).

 Post-heating is on.

10:20 Time.

 Filter guard alert.

 Maintenance reminder alert.

 Fireplace/booster switch on. The fireplace/booster switch is activated in this display by simultaneously pressing down the + and – buttons for 2 seconds.

 Week clock control on.

Fan speed can be changed in this display with the + and – buttons (see Section 3.1., items 7 and 8 in the figure).

##### 3.2.2. Moving to the settings menu

To settings menu  
See manual

In order to move the control panel to the settings menu, press the + and – buttons simultaneously. In the Settings menu you can change setpoints for the ventilation unit.

##### 3.2.3. Week clock control

Week program  
on

Week clock control can be activated by pressing the + button and deactivated by pressing the – button. Week clock control is on when the symbol of week clock control is shown in the main display. In week clock control, the base fan speed and supply air temperature of the unit are adjusted in accordance with the programme as described in Section 3.3.4.

##### 3.2.4. Content display

RH1 35% RH2 40%  
CO2 0821 PPM

The content display shows humidity and carbon dioxide content. The corresponding sensors are required (options).

##### 3.2.5. Temperature display

Out 20 In 20  
Sup. 20 Exh. 20

The temperature display shows the temperatures of outdoor air, indoor air, supply air and exhaust air. The accuracy of the temperature sensors is  $\pm 2$  °C.

##### 3.2.6. Setting supply air temperature

Temp. setting  
20C

Supply air temperature setting is changed with the + and – buttons. When the unit is equipped with the MLV unit, its cooling function starts when supply air temperature exceeds the setpoint temperature for supply air. **NOTE!** When choosing temperature make sure that there is not too cold air in the supply air duct (risk of condensation).



# VALLOX 200 SE

## INSTRUCTIONS FOR USING THE CONTROL PANEL

### 3.3. Settings menu

You can reach the Settings menu from the Operating menu as indicated in section 3.2.2. The displays of the Settings menu (Sections 3.3.1.–3.3.26.) can be scrolled with the scrolling buttons. (See Section 3.1., items 5 and 6 in the figure.)

#### 3.3.1. Setting base fan speed

MIN speed  
1

The desired base fan speed (minimum fan speed) is selected with the + and – buttons. Active when week clock control is not on. Week clock control changes this speed.

#### 3.3.2. Moving to the operating menu

To main menu  
Press + and -

You can return to the operating menu by pressing the + and – buttons simultaneously.

#### 3.3.3. Erasing the week programme

Erase week prog.  
Press + and -

The week programme can be totally erased by simultaneously pressing the + and – buttons.

#### 3.3.4. Week programme programming

Adjust week prog.  
Press + and -

You can access the programming mode for the week clock programme by simultaneously pressing the + and – buttons. See Section 3.4.1.

#### 3.3.5. Adjusting time

Adjust time  
Press + and -

You can adjust time by simultaneously pressing the + and – buttons. For more details, see Section 3.4.2.

#### 3.3.6. Mode of operation of the maximum speed setting

MAX Speed limit  
with adjustments

The maximum fan speed setting can be selected to be active either in connection with (carbon dioxide and humidity) adjustments or permanently. The selection is done with the + and – buttons.

#### 3.3.7. Choosing language version

Kieli / Language  
English

Select the desired language (German, English, Swedish, French or Finnish) with the + and – buttons.

#### 3.3.8. Restoring factory settings

Factory settings  
see manual

The general factory settings can be restored by pressing the + and – buttons simultaneously. Remember to ensure that the setpoints are in accordance with the factory settings for this unit. Especially, check the unit model (electricity/water) and change if needed as stated in Section 3.3.20.

#### 3.3.9. Adjustment interval

Adjust interval  
10

The adjustment interval for humidity and carbon dioxide adjustments is selected with the + and – buttons. The adjustment interval refers to minutes.

#### 3.3.10. Resetting the service reminder

Mainten. reset  
Press + and -

The maintenance reminder is reset by pressing the + and – buttons simultaneously. This turns off the maintenance reminder symbol (🔧) on the main display.

#### 3.3.11. Contrast of the control panel display

Display contrast  
05

The contrast setting for the control panel display is changed with the + and – buttons.

#### 3.3.12. Address of the control panel

Panel address  
1

The address of the control panel is changed with the + and – buttons. Two control panels cannot have the same address. If control panels have the same address, they will go to bus fault state and will not operate.

#### 3.3.13. Controlling the fan on the extract air side

DC fan exhaust  
100%

The desired adjustment value for the direct current fan is selected with the + and – buttons. The rotation speed of the extract air fan can be decreased by decreasing the percentage.

## INSTRUCTIONS FOR USING THE CONTROL PANEL

### 3.3.14. Controlling the fan on the supply air side

DC fan - supply  
100%

The desired adjustment value for the direct current fan is selected with the + and – buttons. The rotation speed of the supply air fan can be lowered by decreasing the percentage value.

### 3.3.15. Changing the operating temperature of heat recovery cell bypass

Cell bypass  
10C

The desired cell bypass temperature is selected with the + and – buttons. If outdoor temperature is lower than cell bypass temperature, the summer/winter damper is in the winter position.

### 3.3.16. Setpoint of the basic humidity level

Basic %RH level  
40%

The desired setpoint is chosen with the + and – buttons when manual adjustment has been selected as the Rh level setting (humidity setting, Section 3.3.19).

### 3.3.17. Mode of operation of the fireplace/booster switch

Switch type  
Fireplace switch

The mode of operation of the switch (either fireplace or booster switch) is selected with the + and – buttons.

### 3.3.18. Choosing cascade control for supply air temperature

Cascade adjust  
Off

Cascade control is chosen to be on or off with the + and – buttons.

### 3.3.19. Choosing basic humidity level

Rh-level setting  
automatic

The basic humidity level can be chosen as either automatic or manual. The selection is done with the + and – buttons.

### 3.3.20. Choosing post-heating for the unit

Radiator type  
electric rad.

A water or electric radiator is selected with the + and – buttons, depending on the type of post-heating radiator the unit is equipped with.

**Note! Choosing the wrong type of post-heating may cause a faulty post-heating function.**

### 3.3.21. Choosing maintenance reminder interval

Maintenance rem.  
04

The interval for the maintenance reminder is selected with the + and – buttons. The maintenance reminder interval refers to months.

### 3.3.22. Hysteresis of antifrost function in heat recovery cell

Hysteresis  
03C

The hysteresis of the antifrost function in the heat recovery cell is selected with the + and – buttons.

### 3.3.23. Stopping temperature of supply air fan for the antifrost function in the heat recovery cell

Supply fan stop  
05C

The stopping temperature of the supply air fan for the antifrost function in the heat recovery cell is chosen with the + and – buttons.

### 3.3.24. Pre-heating temperature for antifrost function in the heat recovery cell

Preheater  
07C

The preheating temperature for the antifrost function of the heat recovery cell is chosen with the + and – buttons.

**MLV unit:** Choose outdoor air temperature at which preheating is on. (Note! Temperature < the temperature of the liquid circulating in the radiator.)

### 3.3.25. Changing the setpoint for carbon dioxide adjustment

CO<sub>2</sub>-setting  
0900 PPM

The setpoint for CO<sub>2</sub> adjustment is chosen with the + and – buttons.

### 3.3.26. Choosing maximum fan speed

MAX speed  
8

The desired maximum fan speed is selected with the + and – buttons. Maximum fan speed is on either with adjustments or always. See Section 3.3.6. Mode of operation of maximum speed limitation.



# VALLOX 200 SE

## INSTRUCTIONS FOR USING THE CONTROL PANEL

### 3.4. Week clock control

#### 3.4.1. Week programme programming

D	Hr	Sp	Tmp	Exit
1	12	5	20	Exit

↑  
Cursor

D Day 1...7  
1 = Monday, 2 = Tuesday, etc.

Hr Hours, 0...23

Sp Fan speed, 1...8

Tmp Supply air temperature, 10...30 °C

Exit Save the setting and exit

N No change to previous

The week programme can be used to set the desired fan speed (base fan speed) and supply air temperature for each hour of the day on seven days a week.

The week programme overrides manual adjustments.

Carbon dioxide and humidity adjustment can increase fan speed but never decrease it below the base fan speed set in the week programme.

#### Example: Monday

Fan speed is decreased to speed 2 and supply air temperature to 17 °C between 7:00 (7 a.m.) and 16:00 (4 p.m.). After that, fan speed is raised to speed 4 and supply air temperature to 20 °C. For the evening, fan speed is boosted to speed 6 between 19:00 and 21:00 (7 p.m. and 9 p.m.) for the period when a sauna bath is taken, after which fan speed is lowered back to 4.

Move the cursor with the arrow keys and change values with the + and - buttons. Note that Exit and saving are done when the programming is finished by moving the cursor below the word Exit and pressing + or -.

D	Hr	Sp	Tmp	Exit
1	7	2	17	Exit

Changes in fan speed (Speed) and supply air temperature (Temp.) are only made for the hours desired; in other cases, use N (no change to previous).

Monday (D=1), time 07:00 (H=7), fan speed 2 (Speed=2), supply air temperature 17 °C (Tmp.=17). Move the cursor to the following hour.

D	Hr	Sp	Tmp	Exit
1	16	4	20	Exit

Monday (D=1), time 16:00 (H=16), fan speed 4 (Speed=4), supply air temperature 20 °C (Tmp.=20). Move the cursor to the following hour.

D	Hr	Sp	Tmp	Exit
1	19	6	N	Exit

Monday (D=1), time 19:00 (H=19), fan speed 6 (Speed=6), no change in supply air temperature (Tmp.=N).

Move the cursor to the following hour.

D	Hr	Sp	Tmp	Exit
1	21	4	N	Exit

Monday (D=1), time 21:00 (H=21), fan speed 4 (Speed=4), no change in supply air temperature (Tmp.=N).

Move the cursor to the following day.

Similar changes have to be made separately for each day. Finally, exit the programming mode by selecting Exit. If you wish, you can erase the week programme as indicated in Section 3.3.3. You can then start programming from the start. You can see the settings programmed by choosing a day and by scrolling the hours with the + or - button.

#### 3.4.2. Adjusting time

day	hour	min	Exit
1	15	30	Exit

↑  
Cursor

day Day 1...7  
1 = Monday, 2 = Tuesday, etc.

hour Hours, 0...23.

min Minutes, 0...60

Exit Save the setting and exit

Move the cursor with the arrow keys and change values with the + and - buttons. Exit and saving are done when the programming is finished.

Monday (D=1), time 15 (H=15), minutes (M=30).

Time is maintained even though there is a power failure.

### 3.5. Factory settings

#### VALLOX DIGIT 200 SE has the following factory settings

Base fan speed	=	1
Maximum fan speed	=	8
Carbon dioxide adjustment (CO <sub>2</sub> )	=	900 ppm CO <sub>2</sub>
Adjustment interval	=	10 min.
Freezing protection (cell)	=	6 °C
Freezing protection hysteresis	=	3 °C (1 °C/MLV unit)
Preheating setting	=	8 °C
Maintenance reminder	=	4 months
Cell bypass	=	12 °C
Cascade control	=	not used
Humidity level (RH level) adjustment	=	automatic
Switch type	=	fireplace switch
Supply air setpoint	=	10°C (18°C/MLV unit)

## MAINTENANCE INSTRUCTIONS

### 4. Maintenance instructions

#### 4.1. Filters

When the indicators of the maintenance reminder or filter guard are seen on the display of the control panel, check the cleanliness of the filters.

Outdoor air is filtered in the unit with two kinds of filters. A G4 class coarse filter (A) filters off insects, heavy pollen and other dust. An F7 class fine filter (B) filters off fine dust invisible to the eye. Extract air is filtered with a similar G4 class filter as outside air.

Clean the coarse filters (A) when needed, i.e. by washing them 2 to 4 times a year and whenever the filter guard indicates a need for maintenance. When you open the upper door of VALLOX 200 SE, the security switch (T) turns voltage off. Wash the filters with +25...30 °C warm water and washing-up liquid, pressing them smoothly. Do not handle the filters with force. When washing is done properly, filters stand cleaning 3 to 4 times. In other words, **you have to replace them at least every two years.**

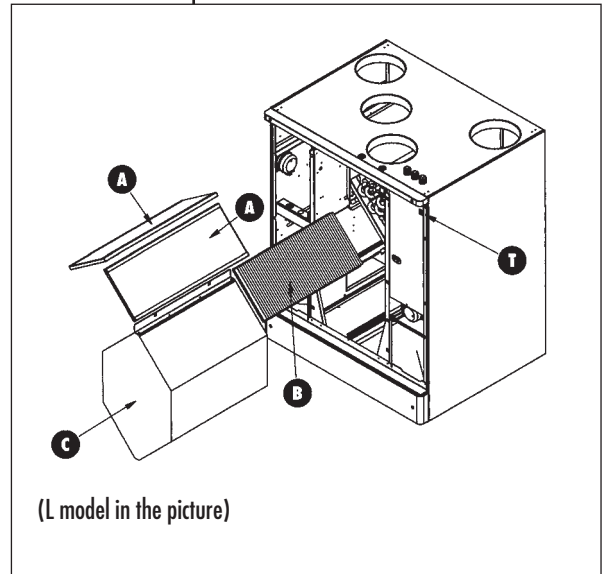

The fine filter (B) is not washable. Clean it at the same time as the G4 class filters by vacuuming it with a brush nozzle. When cleaning, be careful not to break filter material. **To ensure good supply air quality, replace the filter when needed, preferably at one-year intervals, depending on local air quality.** It is recommended to replace filters in autumn. This way the filters stay cleaner through the winter and can effectively filter off dust in the following spring.

In connection with the cleaning of the filters, it is also advisable to check the cleanliness of the heat recovery cell (C) approximately every two years. In this case the lower door must also be taken off. Pull the cell out of the unit by first removing the clamping screws from the upper weather strip of the cell. If the cell is contaminated, soak it in a solution of water and washing-up liquid. Rinse the cell clean with a jet of water. When all the water has drained from between the laminas, push the cell back so that the sealings next to the sliding surfaces are in place and the "up" sticker at the end of the cell points to the corner next to the upper support.

#### 4.2. Fans

Check the cleanliness of the fans in connection with the maintenance of the filters and heat recovery cells. If needed, clean them. Before cleaning remove the fans from the unit.

Remove the fans from their fixing plate by opening their mounting nuts. After that, remove the electrical fan cable connectors. Remove the fans from the unit.

Clean the fan blades with compressed air or with brush. Each blade has to be so clean that the fans stay balanced. Do not remove the balancing pieces attached to the fan blades.

**If you use water in cleaning the unit or its parts, do not let it flow into the electrical parts.**

VALLOX 200 SE filters and heat recovery cell. The units are available in right and left handed models.

In the L model, outdoor air comes to the unit from the channel outlet closest to the left side, whereas in the R model it comes from the channel outlet closest to the right side.

#### REMEMBER!

Clean the filters when needed, preferably 2 to 4 times a year. Set the maintenance reminder interval as needed. See Section 3.3.21. (The setting depends on the cleanliness of outdoor and indoor air).

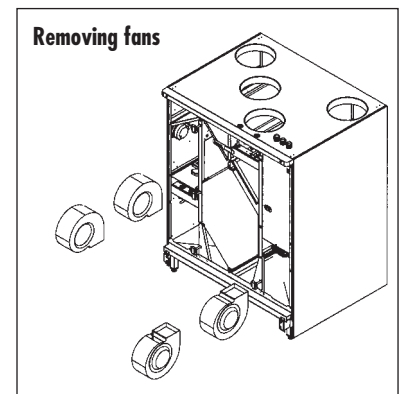



# VALLOX 200 SE

## MAINTENANCE INSTRUCTIONS

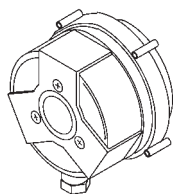

Pressure difference switch

### 4.3. Filter guard (option)

VALLOX 200 SE can be equipped with an optional filter guard. The filter guard symbol  normally lights up in the main display at speeds 7 and 8, when the filters are clean, and this does not require any maintenance activities. If the symbol does not light up at speed 8, the pressure in the ventilation ductwork of the building differs from the factory setting. In that case, adjust the filter guard setpoint lower in the inside of the unit (see Section 2.15). If the filter guard symbol lights up at fan speed 4 or 5, the filters need cleaning. If they are clean, the lighting up may be caused by too dense a mosquito net installed in the external grille or by the closing of the supply air valves in the rooms. If, after checking these things, the symbol continues to light up at small speeds, adjust the setpoint greater.

### 4.4. Condensing water

During the heating season, humidity of extract air condenses into condensing water. Water formation may be abundant in new buildings or if ventilation is low compared to the humidity build-up caused by the residents. Condensing water needs to flow out from the ventilation unit without hindrance. In connection with maintenance, e.g. in autumn before the beginning of the heating season, make sure that the condensing water outlet (L) in the bottom tank is not clogged. You may check it by pouring a little water in the tank. Clean if necessary. Do not let water flow into electrical devices.

You are able to see the condensing water outlet by removing the base plate. The plate has been fixed with two slothead screws. If a condensing water tank is in use, it can be drawn out by pulling it forward. The tank can be removed for emptying and cleaning.

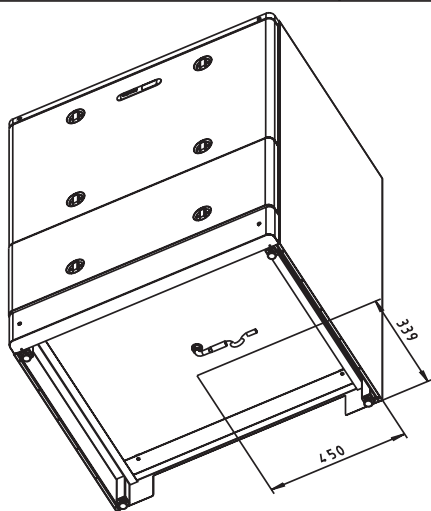

Location of condensing water connection

	SYMPTOM	REASON	DO THIS
1	<b>Outdoor air coming to the dwelling is cold.</b>	<ul style="list-style-type: none"> <li>• Air cools down in the attic ducts.</li> <li>• The heat recovery cell is frozen, which is why extract air cannot heat outdoor air.</li> <li>• The post-heating radiator does not work.</li> <li>• The extract air filter or the cell is clogged.</li> <li>• The initial adjustment of ventilation has not been done.</li> </ul>	<ul style="list-style-type: none"> <li>• Check the insulation of the attic ducts.</li> <li>• If the heat recovery cell is frozen, check the setpoint for freeze protection. The setpoint for freezing protection can be raised by 1 or 2 °C, or the sensor can be bent closer to the cell, in which case the supply air fan stops earlier (see the instructions for using the control panel in Section 3.3.23). Thaw the cell before closing the door.</li> <li>• If the electric post-heating radiator does not operate, check to see if overheating protection prevents it from operating: press the overheating protection reset button, and measure the temperature of supply air inside the unit when the door is closed. If the radiator does still not work, contact a maintenance company.</li> <li>• If the water-circulating post-heating radiator does not work, check if proper post-heating has been selected (see the instructions for use, Section 3.2.20.), if water is circulating in the radiator and if the temperature of water circulating is high enough. If these steps do not help, contact a maintenance company.</li> <li>• Check if the filters and the heat recovery cell are clean.</li> </ul>
2	<b>Supply air fan keeps stopping</b>	<ul style="list-style-type: none"> <li>• HR cell antifreeze is in operation.</li> </ul> <p><b>NOTE! If you decrease the setpoint too much, the cell may freeze. Compare with list item 1.</b></p>	<ul style="list-style-type: none"> <li>• The fan stops more rarely and the efficiency of the heat recovery cell gets better when the setpoint is decreased by 1 or 2 °C. (See the instructions for using the control panel, Section 3.3.23.)</li> </ul>
3	<b>Supply air fan stops and starts too frequently.</b>	<ul style="list-style-type: none"> <li>• The difference between the stopping and starting temperatures is too small.</li> <li>• The preheating radiator does not work.</li> </ul>	<ul style="list-style-type: none"> <li>• Raise the difference between the stopping and starting temperatures by 1 or 2 °C. It extends the period between stopping and starting. (See the instructions for using the control panel, Section 3.3.22.)</li> <li>• If the (electric) preheating radiator does not operate, check if overheating protection prevents it from operating: press the overheating protection reset button, and measure the temperature of outdoor air inside the unit before the heat recovery cell when the door is closed. If the radiator does still not work, contact a maintenance company.</li> <li>• If the MLV unit does not work, check if liquid is circulating in the radiator and if the temperature of the liquid circulating is high enough. If these steps do not help, contact a maintenance company.</li> </ul>
4	<b>The maintenance reminder symbol (⚠) is displayed and the unit operates otherwise normally.</b>	<ul style="list-style-type: none"> <li>• Maintenance reminder lights up the maintenance reminder symbol in the main display of the control panel at circa 4-month intervals (factory setting).</li> <li>• You may change the interval (see the instructions for using the control panel, Section 3.3.21).</li> </ul>	<ul style="list-style-type: none"> <li>• Check the cleanliness of the filters and the unit. If needed, clean or replace the filters. Also check the external grille.</li> <li>• Reset the maintenance reminder symbol to make it disappear. (See the instructions for using the control panel, Section 3.3.10.)</li> </ul>
5	<b>"Exh air sensor faulty" message is displayed and the unit has stopped.</b>	<ul style="list-style-type: none"> <li>• There is a fault in the freezing protection sensor.</li> </ul>	<ul style="list-style-type: none"> <li>• Contact a maintenance company. Sensor mounting needs to be checked and the sensor has to be replaced if necessary.</li> </ul>
6	<b>"Sup. air sensor faulty" message is displayed and the unit has stopped.</b>	<ul style="list-style-type: none"> <li>• There is a fault in the supply air sensor.</li> </ul>	<ul style="list-style-type: none"> <li>• Contact a maintenance company. Sensor mounting needs to be checked and the sensor has to be replaced if necessary.</li> </ul>
7	<b>"Inp. air sensor faulty" message is displayed and the unit is stopped.</b>	<ul style="list-style-type: none"> <li>• There is a fault in the extract air sensor.</li> </ul>	<ul style="list-style-type: none"> <li>• Contact a maintenance company. Sensor mounting needs to be checked and the sensor has to be replaced if necessary.</li> </ul>
8	<b>"Out air sensor faulty" message is displayed and the unit has stopped.</b>	<ul style="list-style-type: none"> <li>• There is a fault in the outdoor air sensor.</li> </ul>	<ul style="list-style-type: none"> <li>• Contact a maintenance company. Sensor mounting needs to be checked and the sensor has to be replaced if necessary.</li> </ul>



## TROUBLESHOOTING

	SYMPTOM	REASON	DO THIS
9	"Bus fault" message is displayed and the unit operates at speed 1 (check the fan speed)	<ul style="list-style-type: none"> <li>Wiring fault in the carbon dioxide sensor, in the control panel or in the humidity sensor.</li> </ul>	<ul style="list-style-type: none"> <li>Contact a maintenance company. The connections have to be checked and corrected if necessary.</li> </ul>
10	"Freezing alert" message is displayed and the unit is stopped.	<ul style="list-style-type: none"> <li>Antifreeze of the water-circulating radiator is active.</li> </ul> <p><b>NOTE! If there is no non-freezing solution in the water of the radiator, the radiator is at risk of freezing.</b></p>	<ul style="list-style-type: none"> <li>Immediately troubleshoot the situation. Consult a maintenance company to find out if there is any non-freezing solution in the radiator. Check if the circulation pump is broken, the boiler out of operation etc. The situation may pass by itself as soon as supply air temperature exceeds 10 degrees, but do not wait till it happens.</li> </ul>
11	The desired automatic adjustment does not stay on.	<ul style="list-style-type: none"> <li>There is a fault in the humidity or carbon dioxide sensor, one of the sensors is broken or missing.</li> </ul>	<ul style="list-style-type: none"> <li>Contact a maintenance company. The sensor installation and connections have to be checked. (The sensors are optional.)</li> </ul>
12	The unit does not work, the fans are not running and no indicator light is lit in the control panel.	<ul style="list-style-type: none"> <li>The door switch may be broken, or the door is possibly not quite closed.</li> <li>The unit is out of power, e.g. because a fuse has blown.</li> <li>The glass tube fuse (located in the control card behind a protecting plate) the electronics inside the unit may have blown.</li> </ul>	<ul style="list-style-type: none"> <li>Check the door switch and fuses. The unit includes a T800 mA glass tube fuse.</li> <li>If needed, contact a maintenance company (e.g. to check the glass tube fuse).</li> </ul>
13	The unit does not obey the control panel.		<ul style="list-style-type: none"> <li>Remove or switch off the power supply fuse of the unit, located in the distribution panel, or the circuit breaker. Wait for 30 seconds and put the fuse back, or switch the circuit breaker on. If this does not help, contact a maintenance company.</li> </ul>
14	"Carbon dioxide alarm" message is displayed and the unit has stopped.	<ul style="list-style-type: none"> <li>Carbon dioxide alarm. Carbon dioxide content has exceeded 5000 PPM for two minutes. May be caused by a fire.</li> </ul>	<ul style="list-style-type: none"> <li>If there is a fire, take the necessary steps.</li> <li>The unit can be restored to the working state by removing or switching off the power supply fuse of the unit, located in the distribution panel, or the circuit breaker, by waiting for 30 seconds and putting the fuse back or switching the circuit breaker on.</li> </ul>
15	The filter guard symbol (⊠) is displayed and the unit operates otherwise normally.	<ul style="list-style-type: none"> <li>Pressure in the filter guard (pressure difference switch) has risen above the adjustment value or speed is 7 or 8.</li> </ul>	<ul style="list-style-type: none"> <li>Check the cleanliness of the filters and the unit. If needed, clean or replace the filters. Also check the external grille.</li> </ul>

After a power failure, the unit starts at minimum fan speed.  
All the other selected adjustments and setpoints remain in the memory of the unit.

