



VALLOX 130

• 1.09.84E
• 28.10.2008
© VALLOX

Code 3500 E

130 E R
(electric radiator model)

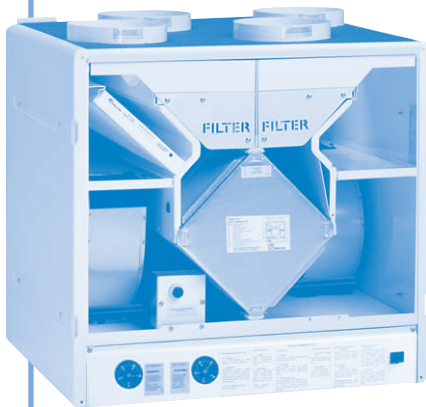

The figures show R models. In the L model duct outlets are in the opposite order. (See page 2.)

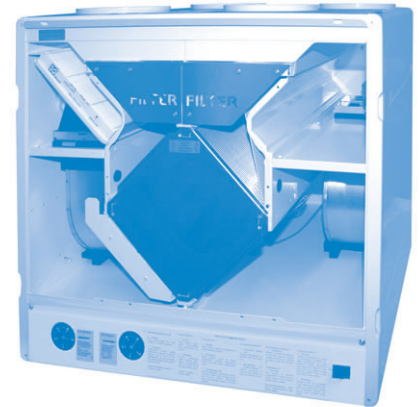

130 E VKL R
(water radiator model)

- Maximum air flow 130 dm³/s, 50 Pa ductwork pressure loss.
- Separate 4-step fan speed controller.
- Supply air filtering G3 and F7.
- Comes standard with in-built heat recovery bypass (for summer use).
- Post-heating with electric or liquid radiator (VKL).
- Preheating (option) VALLOX 1000.
- Defrost automation.
- Fireplace switch function.
- Maintenance switch.
- Silencer unit (option).
- Ceiling mounting plate (option).
- Available as both R and L models.
- 8-step autotransformer enables power selection over a wide range.
- Connection for remote monitoring / remote use with the **VALLOX 1993A YK** control centre.
- Can be controlled with cooker hoods PTXP i 130 / PTXPA i 130.

Technical specifications

Fans	Supply air	210 W	105 dm ³ /s	100 Pa
	Extract air	210 W	125 dm ³ /s	100 Pa
Heat recovery	Plate heat exchanger, efficiency more than 60%			
Heat recovery bypass	Summer / winter damper			
Post-heating	Electric 1000 W radiator or water radiator (VKL)			
Filters	Supply air	G 3 + F 7		
	Extract air	G 3		
Weight	57 kg			
Maintenance switch	Door switch			
Power adjustment	Separate 4-step speed controller, control centre 1993A YK or cooker hoods PTXP / i 130 or PTXPA / i 130			
Input power and data	230 V, 50 Hz, 1.35 kW, 5.9 A. IP 34			
Options	Filter guard Preheating, VALLOX 1000 Fireplace switch function Silencing unit Ceiling mounting plate			

TECHNICAL SPECIFICATION



VALLOX 130 E

TECHNICAL SPECIFICATION

Dimensions and duct outlets

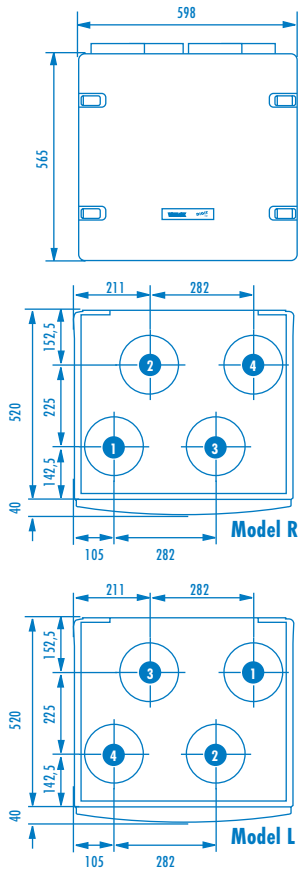

Duct outlets, inner \varnothing 160 mm

- 1 Supply air to the dwelling
- 2 Extract air from the dwelling
- 3 Outdoor air to the unit
- 4 Exhaust air outside

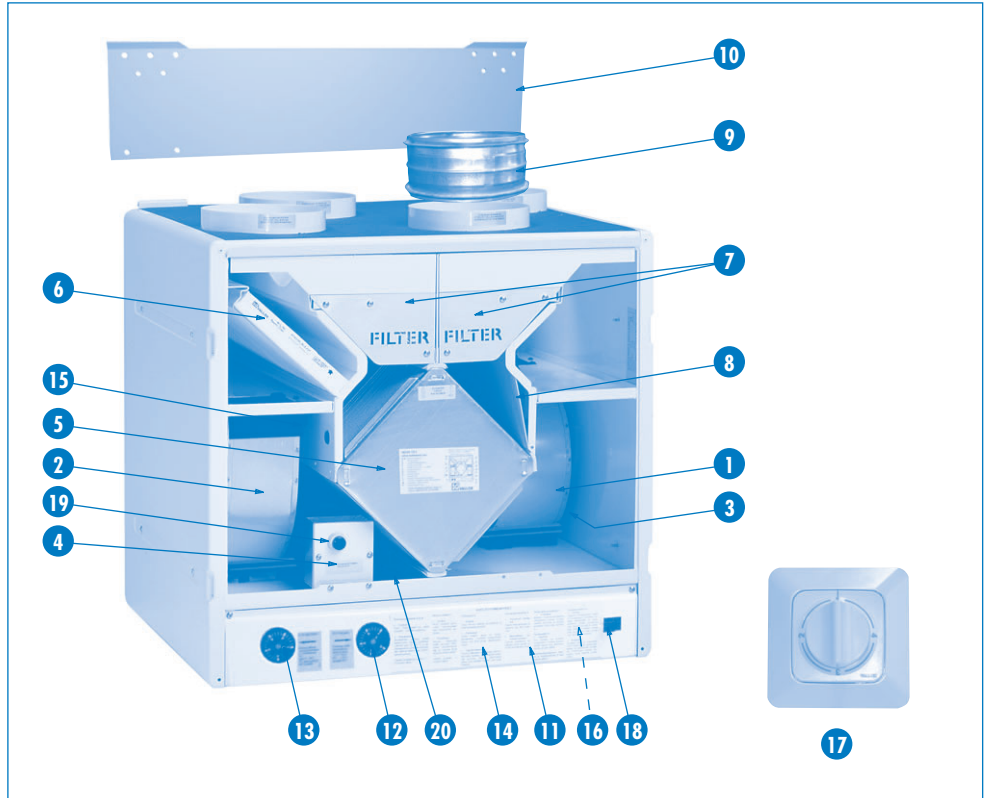

VKL MODEL

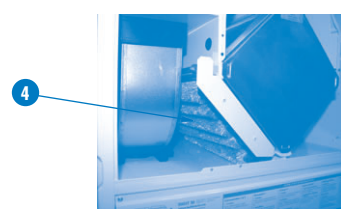

Water radiator (VKL model)

MAIN PARTS

- 1 Extract air fan 210 W
- 2 Supply air fan 210 W
- 3 Electric quick-coupling for fan (behind the fan)
- 4 Post-heating radiator (electric 1000 W / water)
- 5 Heat recovery cell
- 6 Outdoor air filter F7
- 7 Outdoor and extract air pre-filter G3
- 8 Summer / winter damper
- 9 Connection outlets \varnothing 160 mm with seals
- 10 Wall bracket
- 11 Cover of lower housing
- 12 Electric radiator regulating thermostat / water radiator defrost thermostat (VKL model)
- 13 HR cell defrost thermostat
- 14 Electric box (behind the cover)
- 15 Filter guard, optional (not in the picture)
- 16 Filter guard indicator, optional (not in the picture)
- 17 Speed selector switch
- 18 Maintenance switch
- 19 Overheat protection reset button
- 20 Summer / winter damper handle
- 21 Self-actuated one-way dampers (only the VKL model)



Air volumes

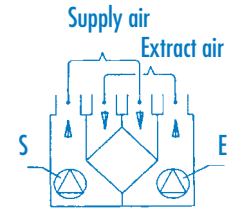
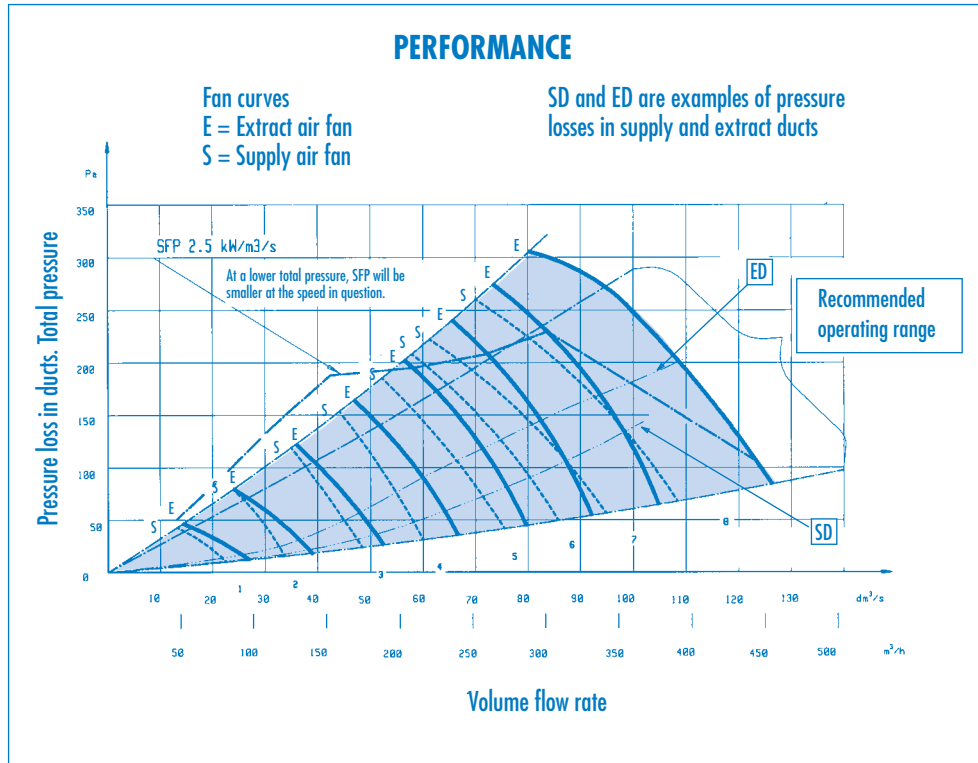

Measuring points after the connection outlet. Fan curves indicate the total pressure available for duct losses.

Fan speeds	Control voltage V	Total input power W
1	60	35
2	80*	55
3	100	80
4	120*	110
5	140	145
6	160*	180
7	180	210
8	230*	310

*) Factory preselected control speeds

Sound values

Hz	Sound power level from 130 E to supply air ducts by octave band L_w , dB				Sound power level from 130 E to extract air ducts by octave band L_w , dB				
	ADJUSTMENT POSITION / VOLUME FLOW RATE				ADJUSTMENT POSITION / VOLUME FLOW RATE				
	2 36 l/s	4 63 l/s	6 90 l/s	8 111 l/s	2 41 l/s	4 67 l/s	6 95 l/s	8 125 l/s	
Medium frequency of the octave band, Hz	63	59	69	74	80	60	68	75	79
	125	56	66	72	74	53	63	69	75
	250	41	53	60	65	41	52	60	65
	500	42	50	57	63	32	41	48	53
	1000	40	51	54	57	29	40	45	49
	2000	23	37	46	53	21	33	41	48
	4000	15	34	43	49		25	33	39
8000		27	39	45			25	33	
L_w , dB	61	71	76	81	61	70	76	81	
L_{wA} , dB(A)	44	55	60	65	41	50	57	62	
A-weighted sound pressure level dB (A) coming from 130 E through the envelope to the rooms where the unit has been installed (10 m² sound absorption)									
ADJUSTMENT POSITION / VOLUME FLOW RATES (supply / extract)									
2 35/37 l/s 4 61/63 l/s 6 86/88 l/s 8 112/115 l/s									
L_{pAr} , dB(A)	27	36	41	46					



VALLOX 130 E

VALLOX SILENCER

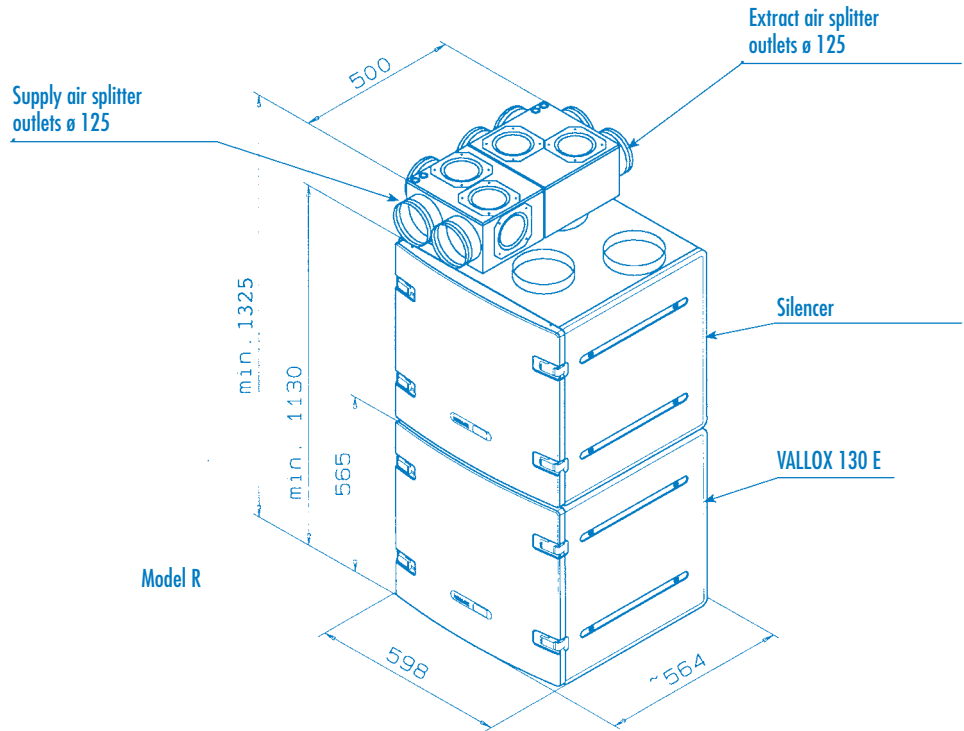

Expected sound levels dB (A) in a room with VALLOX silencer

ROOM SOUND MEASUREMENT MOUNTING



Supply side

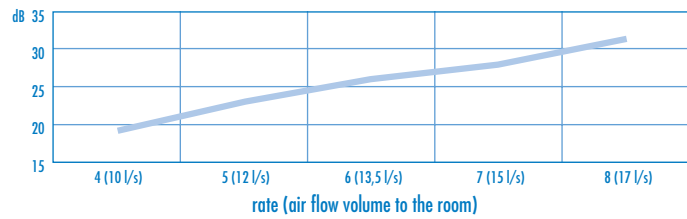

Extract side

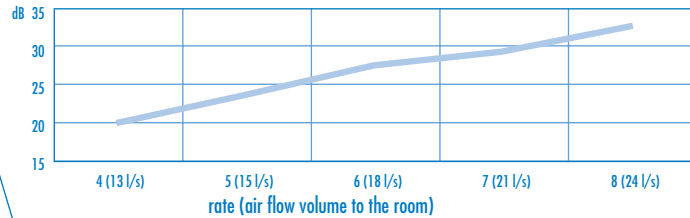

VALLOX 130 E + VALLOX SILENCER



Performance

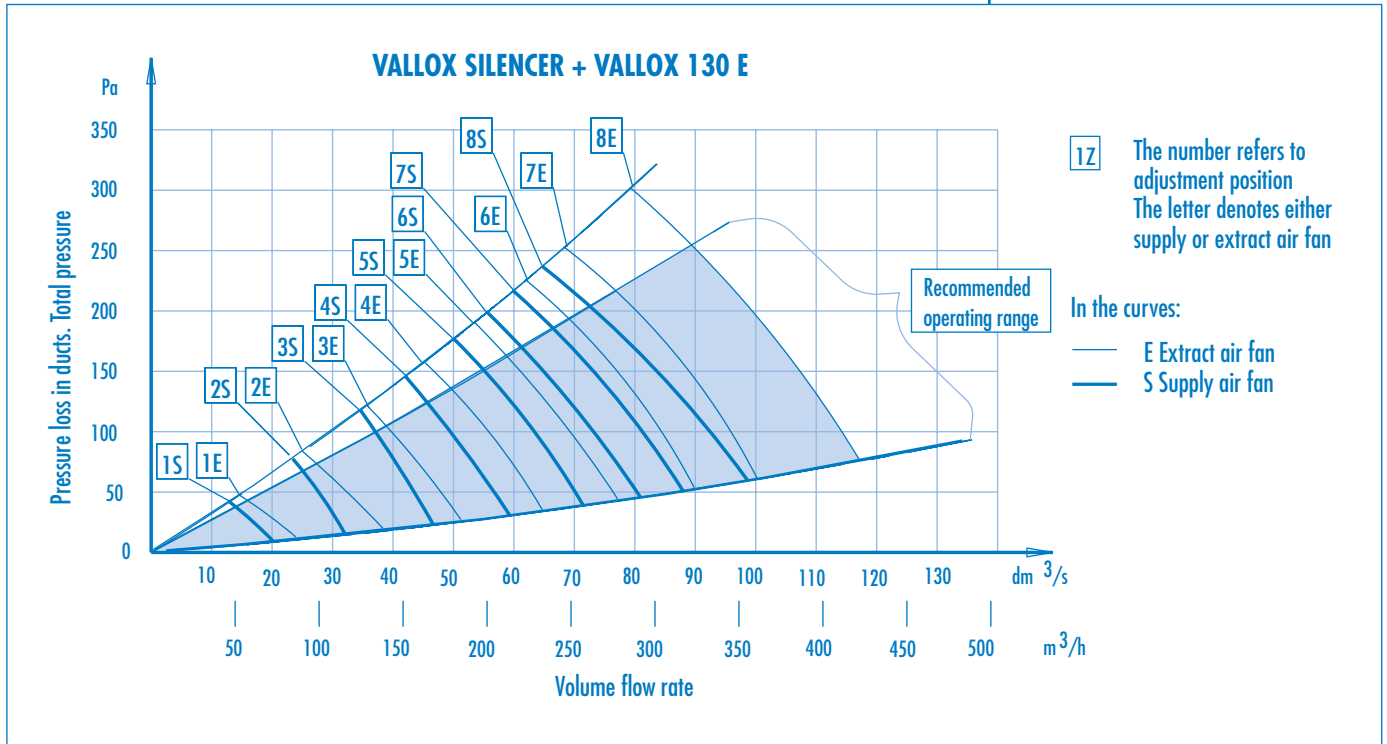

Sound values

Supply air duct		Sound power level in the supply air duct after the silencer by octave band L_w , dB							
		1/60	2/80	3/100	4/120	5/140	6/160	7/180	8/230
ADJUSTMENT POSITION / VOLTAGE, (V) / AIR FLOW, dm ³ /s / PRESSURE, Pa			33/16	44/40	57/45	69/52	75/83	80/105	93/99
Medium frequency of the octave band, Hz	63	63	65	69	72	74	76	78	78
	125	51	51	59	61	64	66	68	69
	250	33	33	39	44	47	50	52	54
	500	24	24	28	32	36	38	41	43
	1000	19	19	22	24	26	27	28	31
	2000	0	0	0	0	7	10	15	19
	4000					0	0	0	13
	8000								0
L_w dB total		65	70	70	72	74	77	78	79
L_{WA} dB(A) total		40	45	45	48	50	53	54	55

Extract air duct		Sound power level in the extract air duct after the silencer by octave band L_w , dB							
		1/60	2/80	3/100	4/120	5/140	6/160	7/180	8/230
ADJUSTMENT POSITION / VOLTAGE, (V) / AIR FLOW, dm ³ /s / PRESSURE, Pa			36/24	47/49	56/42	75/49	85/73	93/95	108/126
Medium frequency of the octave band, Hz	63	57	57	63	65	68	70	71	74
	125	45	45	50	54	58	60	62	65
	250	33	33	40	45	49	51	53	56
	500	12	12	20	25	28	32	34	37
	1000	0	0	12	17	21	25	27	30
	2000			0	0	8	17	21	26
	4000					0	0	0	20
	8000								0
L_w dB total		57	63	63	65	68	70	72	75
L_{WA} dB(A) total		32	38	38	41	45	47	49	52



VALLOX 130 E

VENTILATION ADJUSTMENT



Speed selector



VALLOX 1993 A YK control centre



Cooker hood PTXP /i 130, PTXPA /i 130

Speed selector

VALLOX 130 E delivery includes a four-step speed selector switch. The flush-mounted switch is mounted in a standard instrument box. The switch can be used to select four of the eight speeds for the unit. The speeds selected for the unit are 2, 4, 6 and 8. An expert can select different speeds at the transformer of the unit.

Remote monitoring control

It is sometimes necessary (e.g. in public premises) to control the unit by remote monitoring. The unit can then be controlled by VALLOX control centre 1993A YK, for instance. You can select two speeds and one bypass speed at the centre; the bypass speed can be used to bypass the two first speeds.

The standard four-step switch can be replaced with a corresponding control system, which must be planned by an expert for each specific case.

Control with a cooker hood

When cooking smoke abatement is connected directly to the unit, it can be controlled with cooker hood VALLOX PTXP / i 130 or PTXPA / i 130.

FILTERING

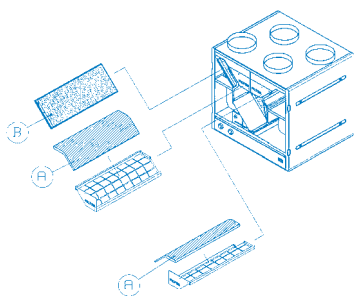

VALLOX 130 E features both extract and supply air filtering before the fans and the heat recovery cell. The unit comes standard with a F7 fine filter (B), which captures fine dust, pollen and dust not seen to the eye, and G3 coarse filters (A) for insects and heavy pollen and room dust, for instance. The filters need to be in place in the unit whenever ventilation is in operation.

FILTER GUARD (option)

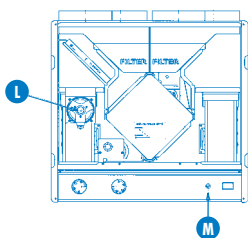

An optional filter guard (L) for the unit monitors the cleanliness of the unit and the supply air filters. The setpoint of the filter guard is set individually for each dwelling so that the filter guard indicator (M) lights up at fan speed 4 when the filters are clean.

FIREPLACE SWITCH FUNCTION (option)

If the unit has been equipped with a fireplace switch (timer), it can be used to stop the extract air fan for a certain period, such as 15 minutes, producing overpressure in the ventilation zone. This makes it easier to light the fireplace, for instance.

The situation will normalise in a while, after the functions stops.

Note! The starting of the extract air fan may weaken draught in the fireplace. During cold winter seasons, the flowing of cold air to the extract ducts may cause the antifreezing and defrost functions to start. If the post-heating radiator does not contain non-freezing solution, there is a freezing risk.

HEAT RECOVERY BYPASS

In winter use the heat recovery cell of VALLOX 130 E recovers heat from the air leaving the dwelling and uses it to heat the air coming from the outside.

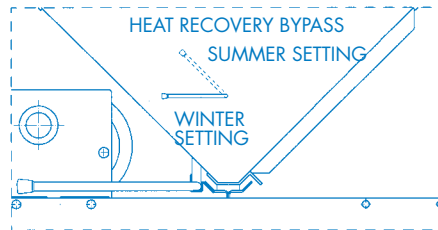

In summer use when it is warm outside, it is unnecessary to heat outdoor air. The heat recovery cell is then bypassed in VALLOX 130 E with the standard damper (A). The position of the damper can be changed using the handle (B). In the summer position air flow through the cell is prevented, and heat recovery bypass is activated.

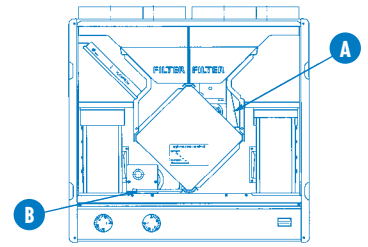

DEFROSTING OF THE HEAT RECOVERY CELL

Water condensing from extract air may freeze in the heat recovery cell. Freezing can be prevented by stopping the supply air fan (standard function) or by switching the (optional) pre-heating resistor on. Both these functions are automatic.

The defrost thermostat (J) stops the supply air fan whenever the temperature of extract air goes down to circa +5°C. The fan restarts when temperature has risen by three degrees, i.e. to +8°C. The threshold value of the thermostat can be adjusted.

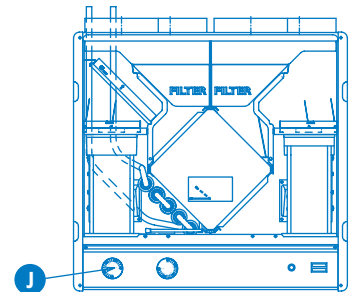

PREHEATING OF OUTDOOR AIR (option)

The outdoor air duct of VALLOX 130 E can be equipped with an optional VALLOX 1000 supply air heater. The sensor of a separate thermostat on the heater is mounted in the exhaust air duct as close to the unit as possible. The supply air heater switches on and the thermostat indicator lights up when exhaust air temperature goes below the setpoint of the thermostat. If exhaust air temperature goes even lower, the defrost thermostat of VALLOX 130 E stops the supply air fan. The preheating resistor switches off when exhaust air temperature is circa 3 °C higher than the value set for the thermostat.

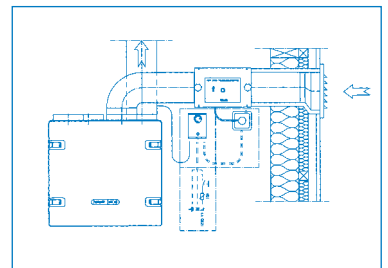

Instructions for regulating the defrost thermostats for VALLOX 130 E and VALLOX 1000 preheater

- The recommended adjustment for the supply air heater thermostat is circa +5 °C...10 °C, however slightly higher than the adjustment for the defrost thermostat of VALLOX 130 E. This enables the functioning of the preheating resistor before the stopping of the fan and ensures that preheating is truly beneficial.
- You can check how defrost functions by comparing the functioning of the supply air fan and preheating. If the fan stops before the supply air heater switches on to heat, you have to adjust the defrost thermostat somewhat lower, from +5 °C to +3 °C for example, or increase the setting for the thermostat of the supply air heater. The indicator of the supply air heater thermostat shows you when the heater switches on to heat.
- The preheating resistor heats even though the supply air fan has stopped. Consequently, underpressure causes air coming from the outside to become warmer before the cell, shortening the time during which the fan is stopped.



VALLOX 1000 supply air heater



VALLOX thermostat 0-40



VALLOX 130 E

POST-HEATING

Electric radiator

VALLOX 130 E comes standard with a 1000 W post-heating radiator T (page 2, item 4). Supply air temperature is adjusted at the thermostat inside the unit (page 2, item 12).

Adjustments can be made within the range of 0...25 °C. **In summer when heat recovery cell bypass is activated, the thermostat has to be set at 0 °C.**

Water radiator

VALLOX 130 E VKL comes standard with a water radiator. The model has no device for adjusting supply air temperature. When the radiator is connected into the heating network, supply air temperature adjusts according to the temperature in the heating network. In summer use the circulation of heating water through the radiator has to be stopped.

Supply air can also be adjusted with a self-actuated thermostat, which is not included in the unit delivery. See the mounting examples in the technical specification in the section describing water-circulating radiator connections.

In the VKL model it is also possible to bring non-freezing heat transfer fluid into the post-heating radiator. In addition, the radiator can be provided with a separate non-freezing heating circuit. It can be built for example with the heat exchanger (V) supplied with the unit.

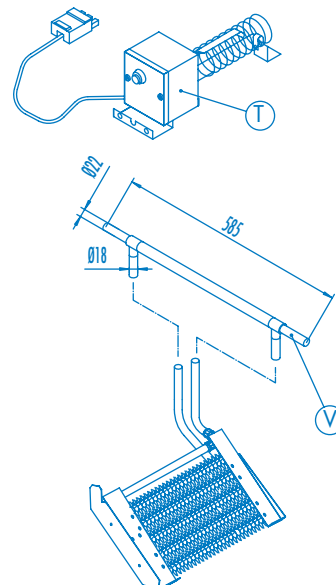

WATER RADIATOR PERFORMANCE

Vallox 130 E minimum supply air temperatures during heating period in underfloor heating connection

Water temperature °C	Water flow dm ³ /s	Supply air temperature °C (and radiator power kW) at different air flow rates					
		35 dm ³ /s	(kW)	60 dm ³ /s	(kW)	80 dm ³ /s	(kW)
25	0,03	19	(0,3)	18	(0,45)	17,5	(0,5)
25	0,05	19,5	(0,35)	18	(0,45)	18	(0,6)
30	0,03	21	(0,4)	19	(0,5)	19	(0,7)
30	0,05	21	(0,4)	20	(0,6)	19	(0,7)
35	0,03	23	(0,45)	21,5	(0,65)	20	(0,8)
35	0,05	23,5	(0,5)	22	(0,7)	20	(0,8)

WATER RADIATOR FREEZING PROTECTION

VALLOX 130 E VKL comes standard with a thermostat (JP) protecting the radiator against freezing. When radiator temperature goes below +5 °C, the thermostat stops the unit and the self-actuated dampers of the fans close. The unit starts and the dampers open as soon as temperature rises above +10 °C. The stopping threshold can be adjusted.

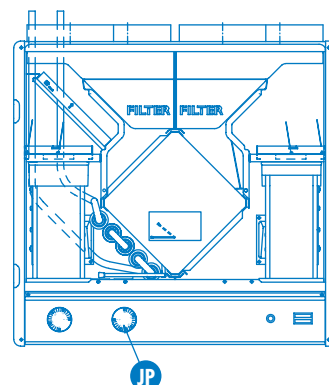

PRESSURE LOSS IN THE WATER RADIATOR

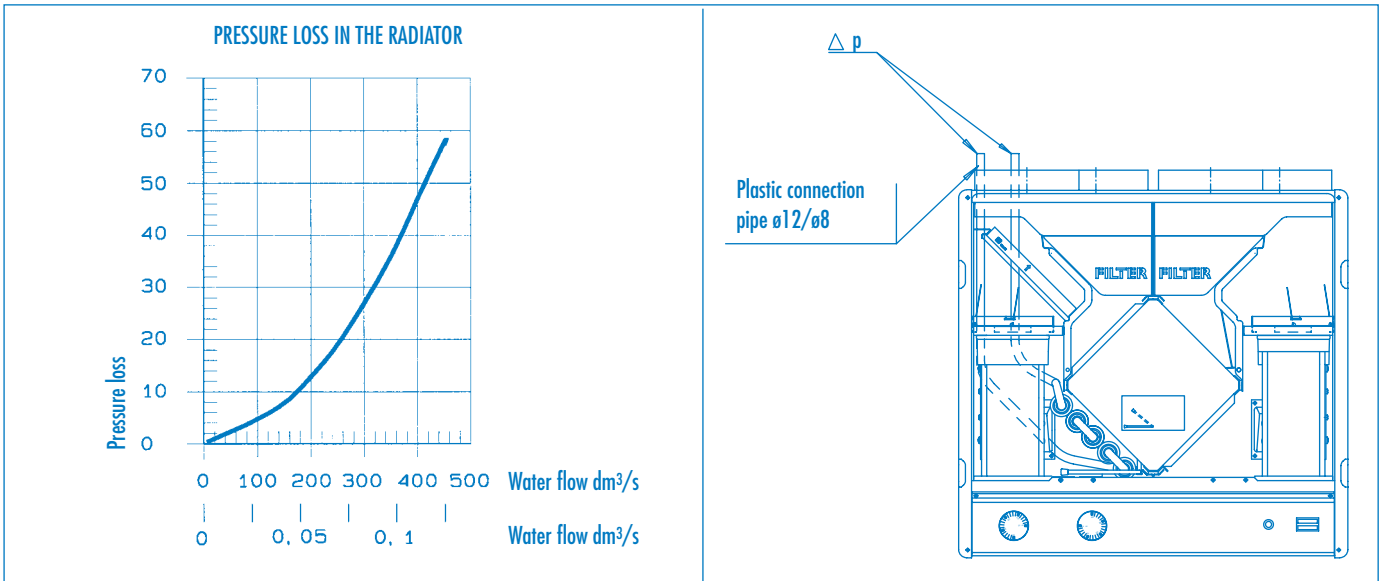

EXAMPLE

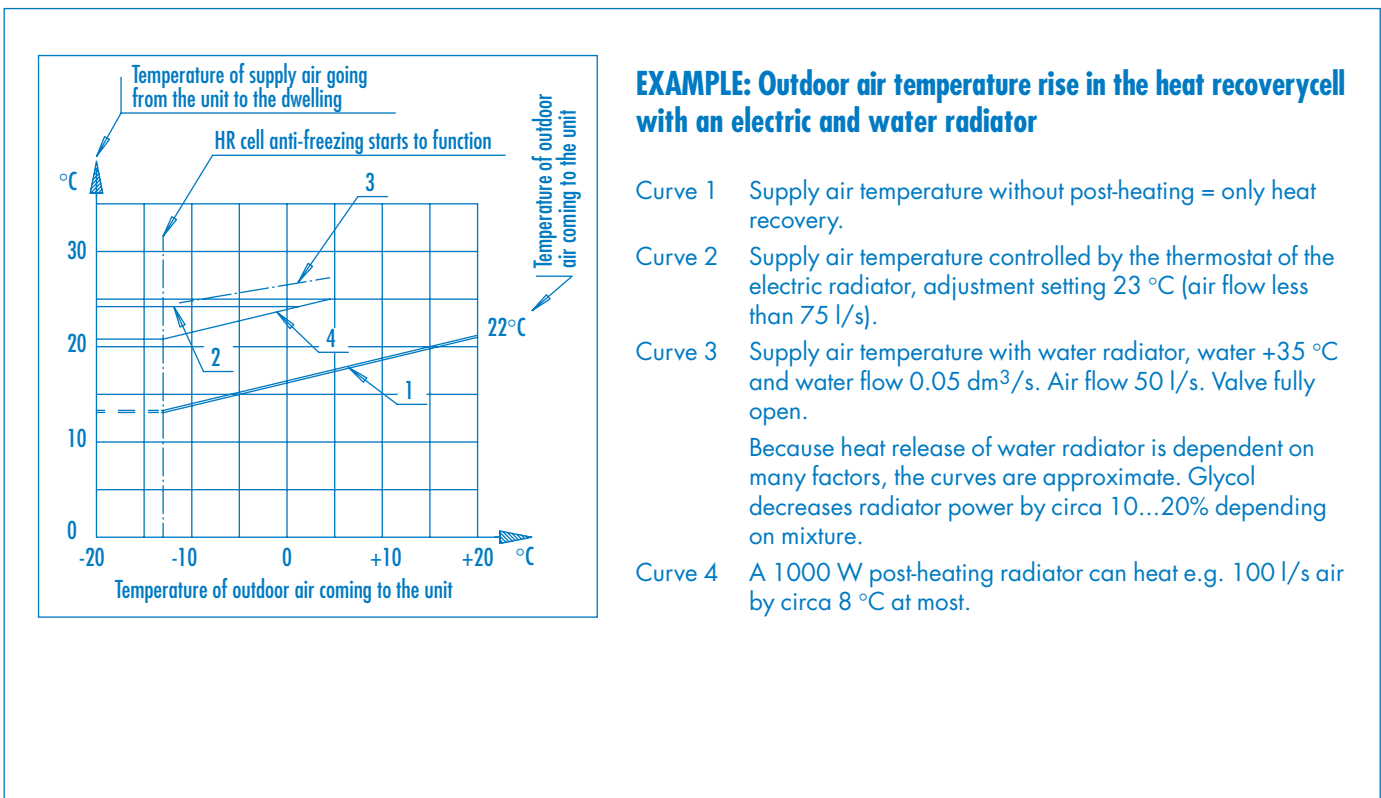



VALLOX 130 E

INTERNAL ELECTRICAL CONNECTIONS / Separate speed selector

VALLOX 130 E model 3500E electrical diagram

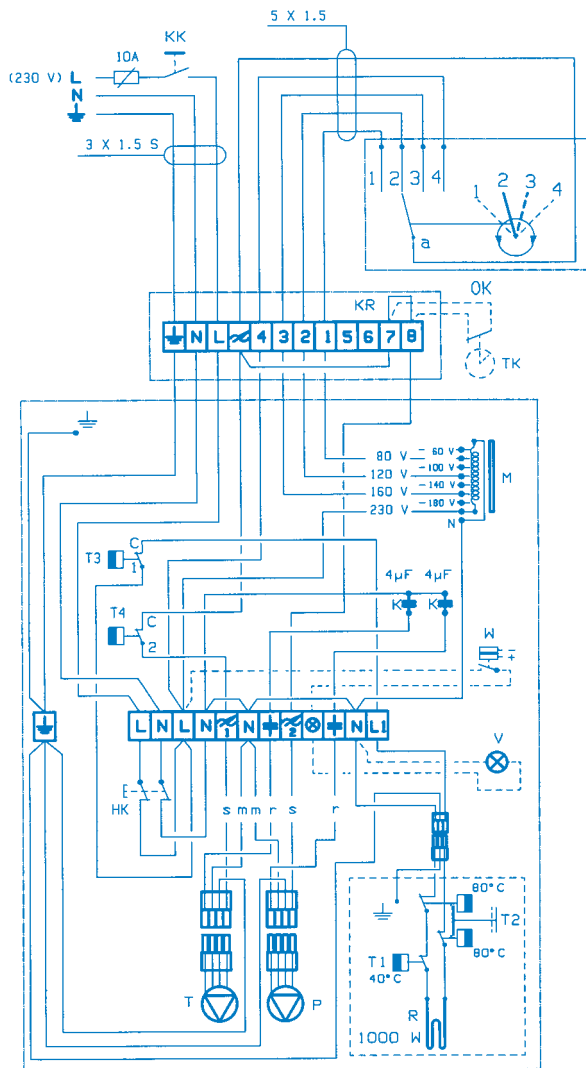

- | | | | |
|----|---|--------------|---------|
| S | Supply air fan | Wire colours | |
| E | Extract air fan | s | = blue |
| T1 | Safety thermostat of the post-heating radiator | m | = black |
| T2 | Overheating protector 2 pcs | r | = brown |
| T3 | Post-heating radiator regulating thermostat +0...+25 °C | | |
| T4 | Defrost thermostat, cell +4 °C | | |
| R | Post-heating radiator | | |
| M | Autotransformer | | |
| K | Capacitor | | |
| W | Filter guard, option | | |
| V | Filter guard indicator, option | | |
| OK | Separate speed selector | | |
| HK | Maintenance switch | | |
| KK | Operating switch | | |
| TK | Fireplace switch, option. For instance a 15-minute timer with opening points. Mounted to replace wire 3-8 | | |
| KR | Connection box (below the unit) | | |

VALLOX 130 E VKL model 3500E electrical diagram

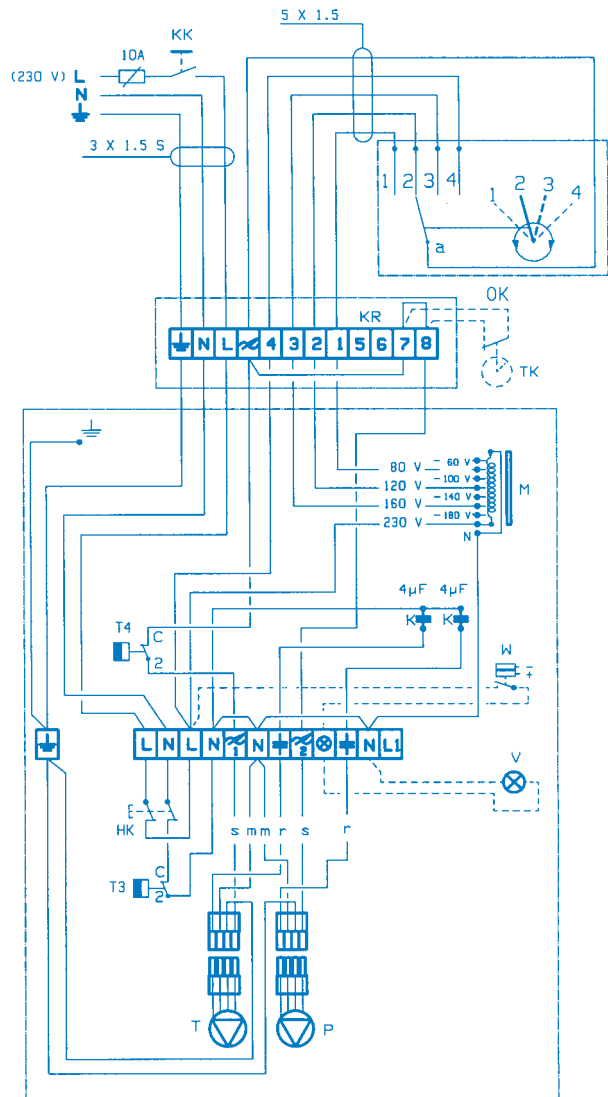

- | | | | |
|----|---|--------------|---------|
| S | Supply air fan | Wire colours | |
| E | Extract air fan | s | = blue |
| T3 | Radiator defrost thermostat +5 °C | m | = black |
| T4 | Defrost thermostat, cell +4 °C | r | = brown |
| M | Autotransformer | | |
| K | Capacitor | | |
| W | Filter guard, option | | |
| V | Filter guard indicator, option | | |
| OK | Separate speed selector | | |
| HK | Maintenance switch | | |
| KK | Operating switch | | |
| TK | Fireplace switch, option. For instance a 15-minute timer with opening points. Mounted to replace wire 3-8 | | |
| KR | Connection box (below the unit) | | |

EXTERNAL ELECTRICAL CONNECTIONS

VALLOX 130 E control with cooker hood PTPX / I 130

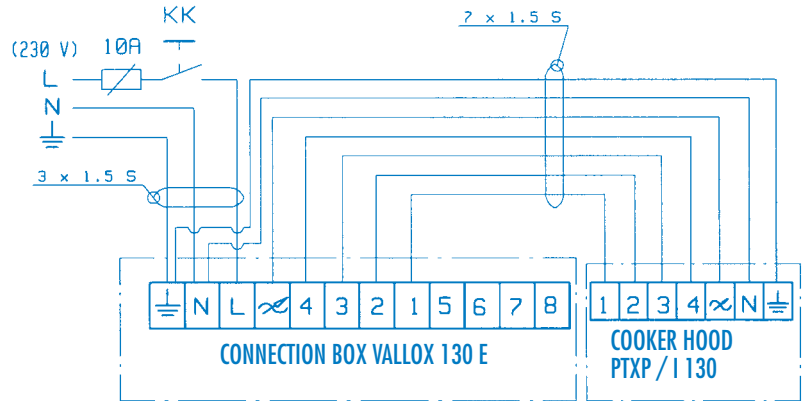

VALLOX 130 E remote monitoring

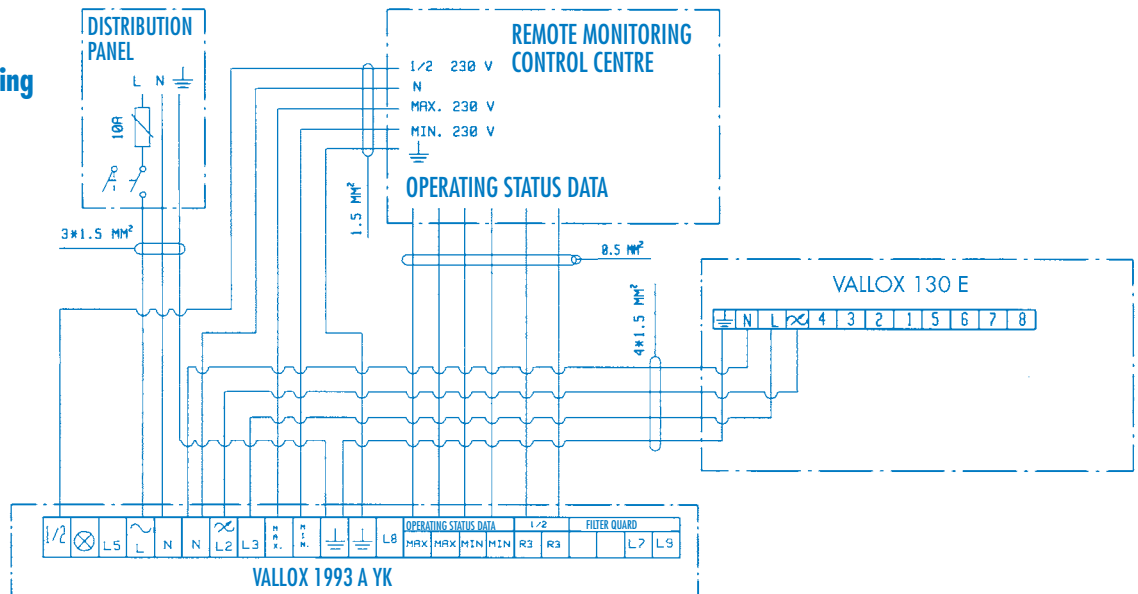



VALLOX 130 E

OPERATION AND FUNCTIONAL DIAGRAM FOR VALLOX 130 E / electrical radiator

CONTROL DIAGRAM VALLOX 130 E / post-heating – electrical radiator

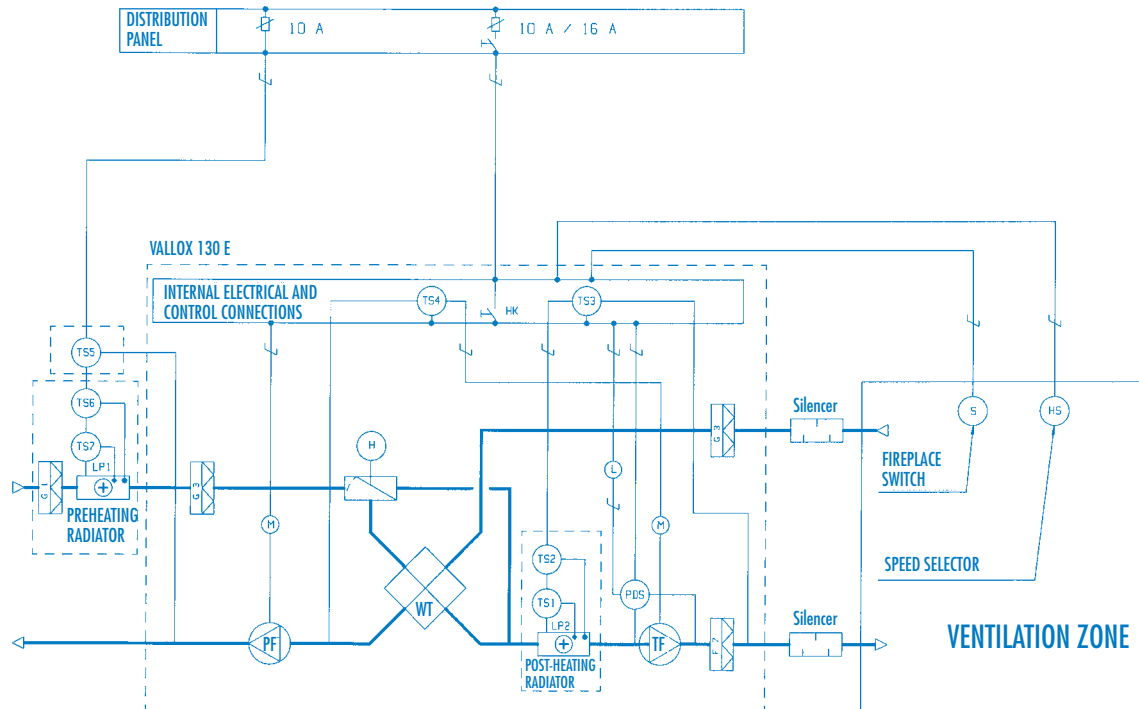

Control of operation

Power supply to the unit is controlled with the 0/1 switch in the distribution panel. There is also a safety switch **HK** inside the unit. It stops power supply when the maintenance door of the unit is opened.

Fan speed adjustment

The fans of the unit, **TF** and **PF**, are controlled depending on operating conditions with a separate 4-step (1, 2, 3 and 4) speed selector switch **HS** located in the ventilation zone.

Supply air temperature

Regulating thermostat **TS3** controls the operation of electric radiator **LP2**, keeping the supply air going out from the unit at the setpoint.

Overheat protector of the electric radiator

Thermostat **TS1** controls the operation of electric radiator **LP2**, preventing radiator surface temperature from exceeding the threshold. As temperature exceeds the threshold, radiator overheat protector **TS2** is triggered and power supply to the radiator is stopped. The overheat protector is reset manually.

Heat recovery bypass

Summer-time bypass of heat recovery cell **HR** is done manually by turning **HR** damper **H** in the bypass position for the summer.

Heat recovery defrost

Thermostat **TS4** of the **HR** cell keeps stopping supply air fan **TF**, thereby preventing the risk of the freezing of the **HR** cell. The fan starts automatically as soon as the risk of freezing has passed. The threshold temperature of the risk of freezing can be set at thermostat **TS4**.

Preheating

Preheater **LP1** is an optional device, which can be mounted in the outdoor duct. The radiator can be used to preheat outdoor air and decrease the stopping of the fan. Thermostat **TS5** switches the radiator on before thermostat **TS4** stops the supply fan.

Preheating radiator overheat protector

Thermostat **TS6** controls the operation of electric preheating radiator **LP1**, preventing radiator surface temperature from exceeding the threshold. As temperature exceeds the threshold, radiator overheat

protector **TS7** is triggered and power supply to the radiator is stopped. The overheat protector is reset manually.

Alarms

Pressure difference switch **PDS** is an optional device for controlling pressure difference on the supply air side. If the pressure difference rises above the setup, because of dirty filters or clogged ducts, an indicator is lit on the front panel of the unit.

Fireplace switch function

The unit can be equipped with an optional fireplace switch **S**. It can be a timer equipped with opening points. Timing period can be 15...30 minutes.

Parts list VALLOX 130 E

Code	Name	Technical data (factory settings in parentheses)	Standard / Option
G3	Filter, extract air and supply air	G3	Standard
F7	Fine filter, supply air	F7	Standard
H	HR bypass damper	Manual	Standard
HS	Speed selector switch	4-step	Standard
LP2	Post-heating radiator	Electric radiator 1 kW	Standard
HR	Heat recovery cell	1-step, efficiency 60 %	Standard
PDS	Pressure difference switch Pressure guard for the supply air side	Adjustment range 0...500 Pa Factory setting 250 Pa	Option
PF	Extract air fan	125 l/s (100 Pa)	Standard
TF	Supply air fan	105 l/s (100 Pa)	Standard
HK	Maintenance switch	Door switch	Standard
TS1	Safety thermostat	Threshold value +40 °C	Standard
TS2	Overheat protector 2 pcs	95 °C, manually reset	Standard
TS3	Post-heating regulating thermostat	Adjustment range 0...25 °C	Standard
TS4	HR defrost thermostat	Factory setting +4 °C	Standard
S	Fireplace switch	Opening points 15...30 minutes	Option
LP1	Preheating radiator	VALLOX 1000, 1 kW	Option
G1	Filter (incl. in LP1)	For preheating radiator LP1	
TS6	Limiting thermostat (incl. in LP1)	Factory setting 17 °C	
TS7	Overheat protector (incl. in LP1)	90 °C, manually reset	
TS5	Regulating thermostat	Vallox thermostat 0...40 °C	Option

CONTROL DIAGRAM VALLOX 130 E VKL / post-heating – fluid radiator

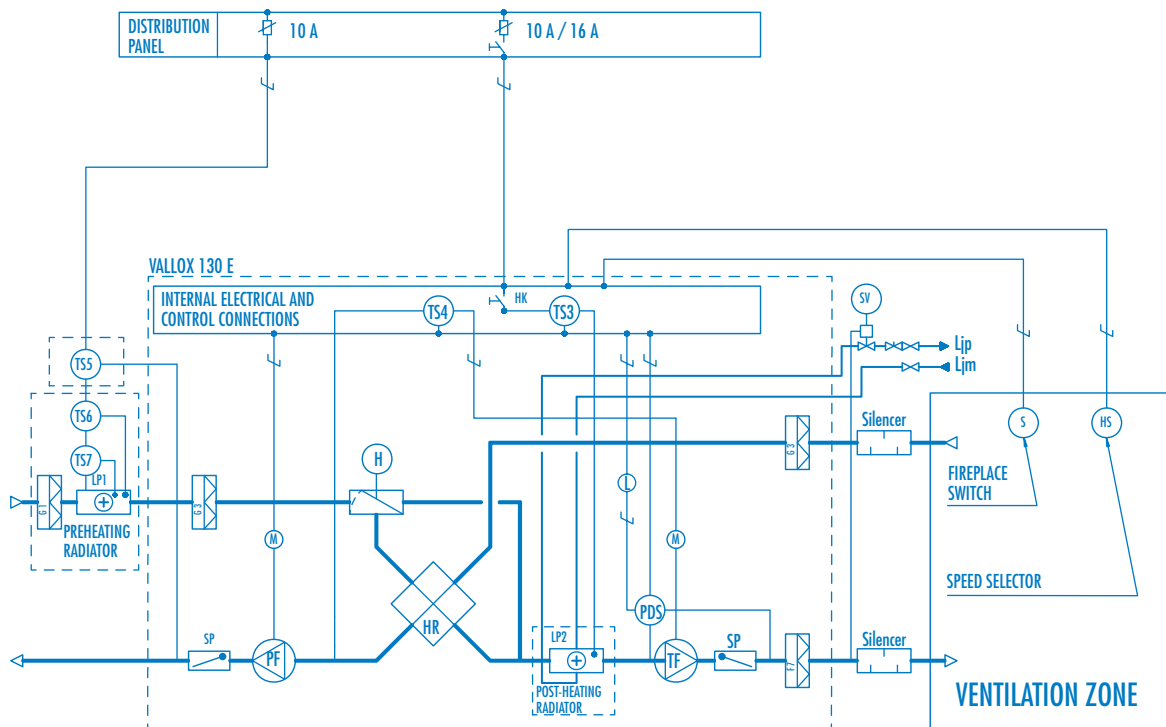

Control of operation

Power supply to the unit is controlled with the 0/1 switch in the distribution panel. There is also a maintenance switch **HK** inside the unit. It stops power supply when the maintenance door of the unit is opened.

Fan speed adjustment

The fans of the unit, **TF** and **PF**, are controlled depending on operating conditions with a separate 4-step (1, 2, 3 and 4) speed selector switch **HS** located in the ventilation zone.

Supply air temperature

Self-actuated control valve **SV** (optional) controls the operation of post-heating radiator **LP2**, maintaining the temperature of supply air going out from the unit at the setpoint value.

Preheating

Preheater **LP1** is an optional device, which can be mounted in the outdoor duct. The radiator can be used to preheat outdoor air and decrease the stopping of the fan. Thermostat **TS5** switches the radiator on before thermostat **TS4** stops the supply fan.

Preheating radiator overheat protector

Thermostat **TS6** controls the operation of electric radiator **LP1**, preventing radiator surface temperature from exceeding the threshold. As temperature exceeds the threshold, radiator overheat protector **TS7** is triggered and power supply to the radiator is stopped. The overheat protector is reset manually.

Heat recovery bypass

Summer-time bypass of heat recovery cell **HR** is done manually by turning **HR** damper **H** in the bypass position for the summer.

Heat recovery defrost

Thermostat **TS4** of the **HR** cell keeps stopping supply air fan **TF**, thereby preventing the risk of the freezing of the **HR** cell. The fan starts automatically as soon as the risk of freezing has passed. The threshold temperature of the risk of freezing can be set at thermostat **TS4**.

Water radiator anti-freeze

When the surface temperature of the water radiator goes below the setpoint, freezing protection thermostat **TS3** of post-heating radiator **LP2** stops the unit and the self-actuated dampers **SP** close, decreasing the freezing risk of the water radiator. The unit starts automatically as soon

as the risk of freezing has passed. The threshold temperature of the risk of freezing can be set at the thermostat **TS3**.

Alarms

Pressure difference switch **PDS** is an optional device for controlling pressure difference on the supply air side. If the pressure difference rises above the setup, because of dirty filters or clogged ducts, an indicator is lit on the front panel of the unit.

Fireplace switch function

The unit can be equipped with an optional fireplace switch **S**. It can be a timer equipped with opening points. Timing period can be 15...30 minutes.

Parts list VALLOX 130 E VKL

Code	Name	Technical data (factory settings in parentheses)	Standard / Option
G3	Filter, extract air and supply air	G3	Standard
F7	Fine filter, supply air	F7	Standard
H	HR bypass damper	Manual	Standard
HS	Speed selection switch	4-step	Standard
LP2	Post-heating radiator	1-row liquid radiator	Standard
HR	Heat recovery cell	1-step, efficiency 60 %	Standard
PDS	Pressure difference switch Pressure guard for the supply air side	Adjustment range 0...500 Pa Factory setting 250 Pa	Option
PF	Extract air fan	125 l/s (100 Pa)	Standard
SV	Thermostat valve with removable sensor	Self-actuated	Option
TF	Supply air fan	105 l/s (100 Pa)	Standard
HK	Maintenance switch	Door switch	Standard
TS3	Water radiator defrost thermostat	Factory setting +5 °C	Standard
TS4	HR defrost thermostat	Factory setting +4 °C	Standard
S	Fireplace switch	Opening points 15...30 minutes	Option
LP1	Preheating radiator	VALLOX 1000, 1 kW	Option
G1	Filter (incl. in) LP1	For preheating radiator LP1	
TS6	Limiting thermostat (incl. in LP1)	Factory setting 17 °C	
TS7	Overheat protector (incl. in LP1)	90 °C, manually reset	
TS5	Regulating thermostat	Vallox thermostat 0...40 °C	Option
SP	Damper 2 pcs	Air flow operated	Standard



VALLOX 130 E

LOCATION AND MOUNTING

130 E location

VALLOX 130 E is mounted in a place where temperature is not less than +10 °C. Without protective casing, the unit has to be located in a place with no acoustic disturbance: store-rooms, technical rooms etc.

VALLOX 130 E can also be located in a damp room.

Fixing

VALLOX 130 E is mounted on the wall with a fixing plate as shown in the adjacent figure. When needed, you can use a lock mounting at the lower part of the unit.

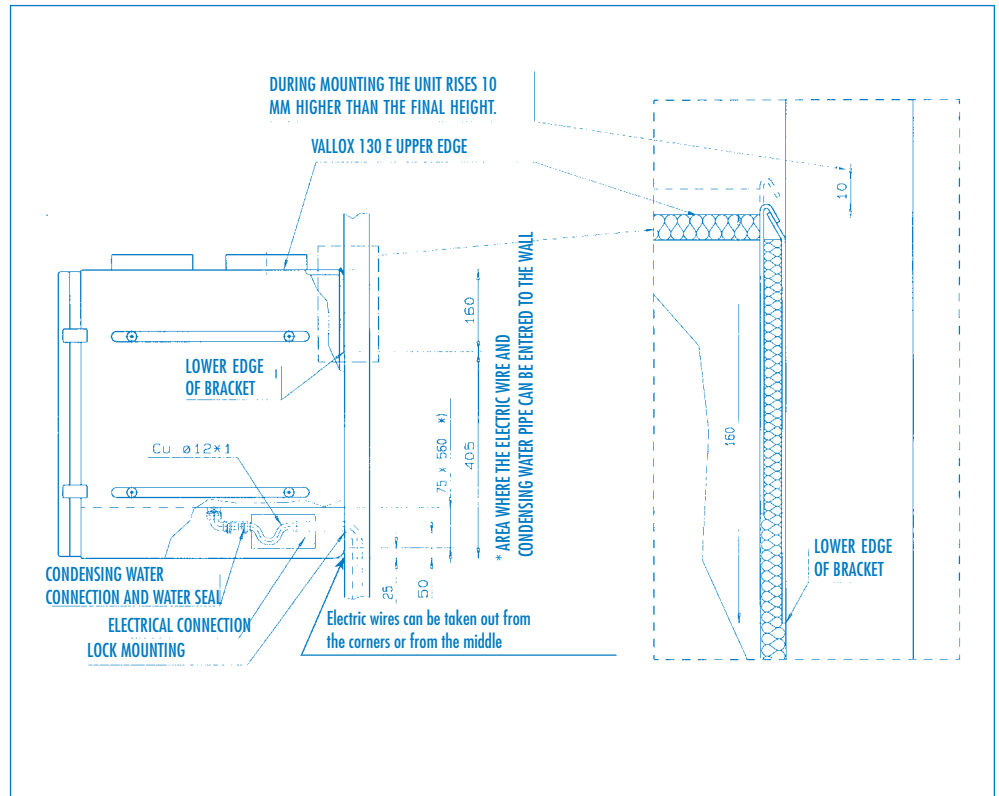

LOCATION AND MOUNTING

Ceiling mounting plate

VALLOX 130 E can be equipped with an optional ceiling mounting plate enabling the mounting of the unit unattached to the wall. The outlet collars in the ceiling mounting plate enable the mounting of the ductwork before mounting the unit.

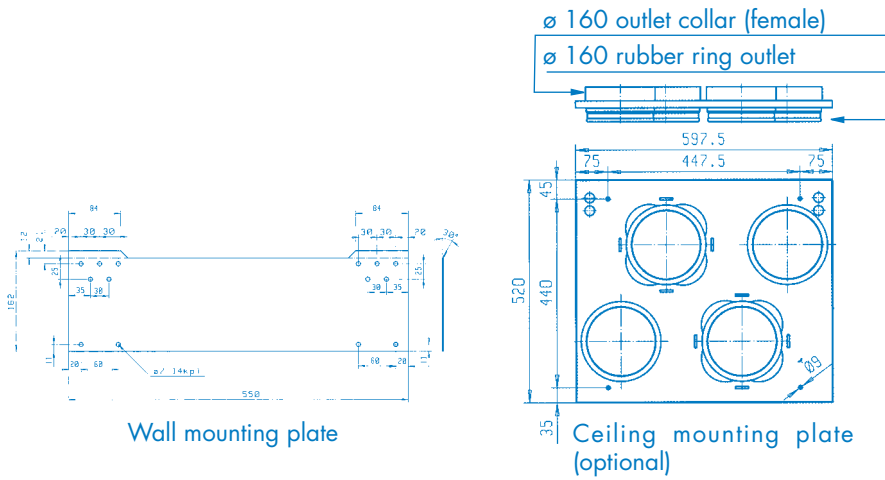

Wall mounting plate

Ceiling mounting plate (optional)

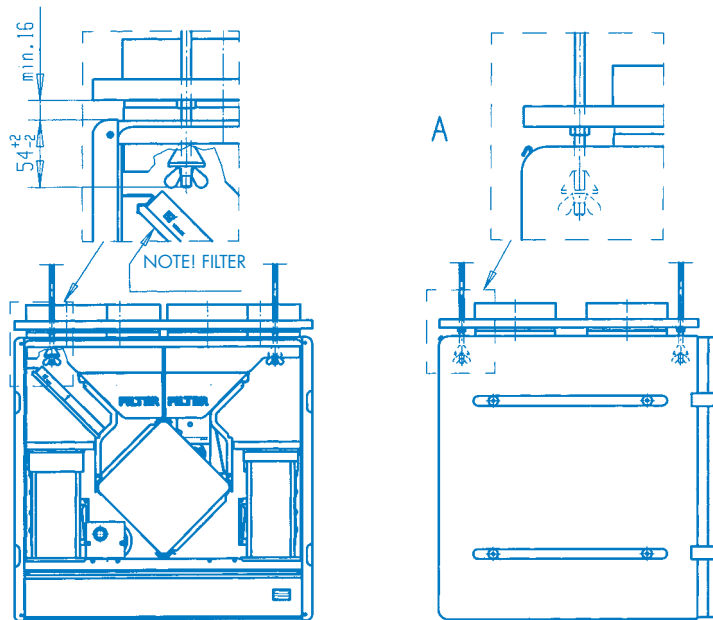

Attaching the ceiling mounting plate to the unit



VALLOX 130 E

LOCATION AND MOUNTING

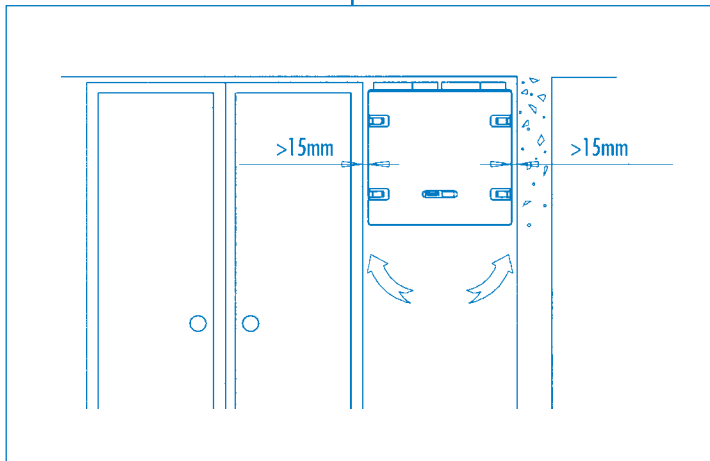

Wall construction

Pay attention to the wall construction when mounting the unit. Avoid mounting the unit on a hollow, echoing dividing wall and on a bedroom wall because of sound conduction, or prevent sound conduction.

Mounting beside a cupboard or wall

You have to leave an empty space of more than 15 mm on the sides of the unit (at least on one of the sides) so that the door latches can be opened and closed when doing maintenance activities. Also leave an empty space of at least 0.6 m in front of the unit.

Condensing water

The delivery includes a water seal. With a pipe connected to the water seal, water condensing from extract air can be led to a floor drain (not straight to the drain) The pipe must not rise after the water seal. The unit has to be mounted level with the horizontal in order to ensure that condensing water can get out of the unit.

NOTE!

If the unit is mounted e.g. above a hot-water accumulator, observe the mounting of the condensing water pipe and the performing of the external connections to the connection box of the unit before mounting.

Example:

The condensing water pipe may be mounted in advance and the connection box can be fixed beside the unit.

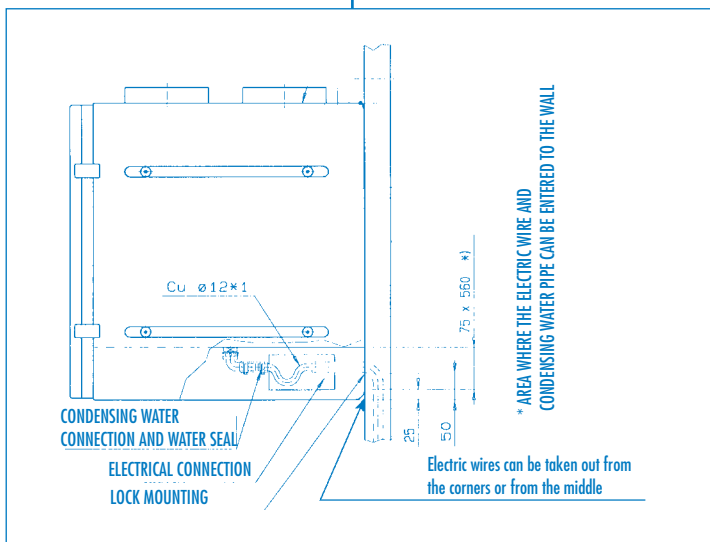

VALLOX

Vallox Oy FI-32200 Loimaa Finland Telephone +358 2 7636 300 Fax +358 2 7631 539
Internet: www.vallox.com.