



Ventilation unit

CONTENTS

INTRODUCTION	2
Safety	3
Installation	3
Warranty	3
Intended use	3
Disposal of the ventilation unit	3
Safety signs used in the instructions	4
Installation options	4
System description	4
Ventilation unit control	5
Ventilation unit control options	5
Filter reminder	5
Ventilation unit setup without a control panel	5
Connecting the ventilation unit to the cloud service	5
Main parts	6
INSTALLATION	7
Mounting on the wall	7
Mounting on the ceiling	7
Mounting the ceiling mounting plate	7
Installing the ventilation unit to the ceiling mounting plate	8
Attic floor penetration plate	8
Removal of condensing water	9
Dimensioning figures and space required for installation of the Vallox Silent Klick siphon	9
Space required by the alternative Vallox Silent Klick siphon installation method (elbow)	9
Measuring and adjusting the air flows of the ventilation unit	9
Dimensions and duct outlets	10
MAINTENANCE	11
Before beginning maintenance work	11
Replacing the filters	11
Cleaning the heat recovery cell	12
Condensing water	12
Cleaning the fans	13
TECHNICAL SPECIFICATIONS	14
Internal electrical connection	15
External electrical connection	16
External electrical connection for controlling the MLV duct radiator ..	17
Duct radiator operation	18
Duct radiator operation chart	19
In the outdoor air duct	19
In the supply air duct	19
Exploded view and spare parts list	20
Conformity certificates	21

**NOTE**

You can register your Vallox MV ventilation unit with the MyVallox Cloud service and sign in into your MyVallox Cloud account at www.myvallox.com.

SAFETY

Safe and appropriate handling requires knowledge of the basic safety regulations, and of the intended use of the ventilation system. Read this manual before operating the ventilation unit. Please keep the manual for later reference. If you lose the manual, it can be downloaded from our website.

This user manual contains all the information necessary for safe operation of the system. All persons who operate and maintain the ventilation system must follow the instructions provided in this manual. Furthermore, all local accident prevention regulations must be observed.

Installation

Installation and setup should only be carried out by a qualified specialist. Electrical installations and connections must be carried out only by an electrician and in compliance with local regulations.

WARRANTY

The guarantee and liability exclude damage resulting from:

- Inappropriate use of the ventilation system or the control unit
- Incorrect or inappropriate installation, setup or use
- Neglect of instructions concerning transportation, installation, use, or maintenance
- Structural or electronic modifications or changes made to the software

INTENDED USE

All Vallox ventilation units have been designed to provide appropriate and continuous ventilation so as to present no threat to health and to maintain structures in good condition.



IMPORTANT

In order to ensure that the indoor air presents no harm to health and remains optimal also for the structures of the building, ventilation must be kept on without disruptions. It is recommended that ventilation be left turned on during long holidays also. This keeps the indoor air fresh and prevents humidity from condensing in the ventilation ducts and structures. It also reduces the risk of moisture damage.

DISPOSAL OF THE VENTILATION UNIT

Do not dispose of electronic devices with household waste. Follow local laws and regulations on safe and ecological disposal of the product.



NOTE

For further information, go to www.vallox.com



WARNING

The unit is not intended for use by children under 8 or by persons with reduced sensory, physical or mental capabilities, or whose lack of knowledge and experience do not ensure safe operation of the unit.

Such persons can use the unit under supervision, or by following the instructions of someone who is responsible for their safety.

Children must be supervised and not be allowed to play with the device.

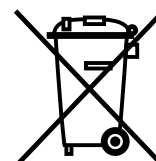

SAFETY SIGNS USED IN THE INSTRUCTIONS



DANGER

Indicates a hazard that will result in death or serious injury if not avoided.



WARNING

Indicates a hazard that can result in death or serious injury if not avoided.



CAUTION

Indicates a hazard that can result in minor or moderate injury if not avoided.



IMPORTANT

Indicates a hazard that can result in damage to property or loss of data if not avoided.



NOTE

Indicates essential information about the product.



TIP

Provides additional information about the use of the product and its benefits.

INSTALLATION OPTIONS

- Vallox 99 MV can be mounted either on the wall, or on the ceiling by using a mounting plate (optional).



NOTE

The standard equipment and available accessories vary from country to country.

SYSTEM DESCRIPTION

1. Internet
2. WLAN
3. Router
4. WLAN/LAN
5. Additional switch
6. Sensors

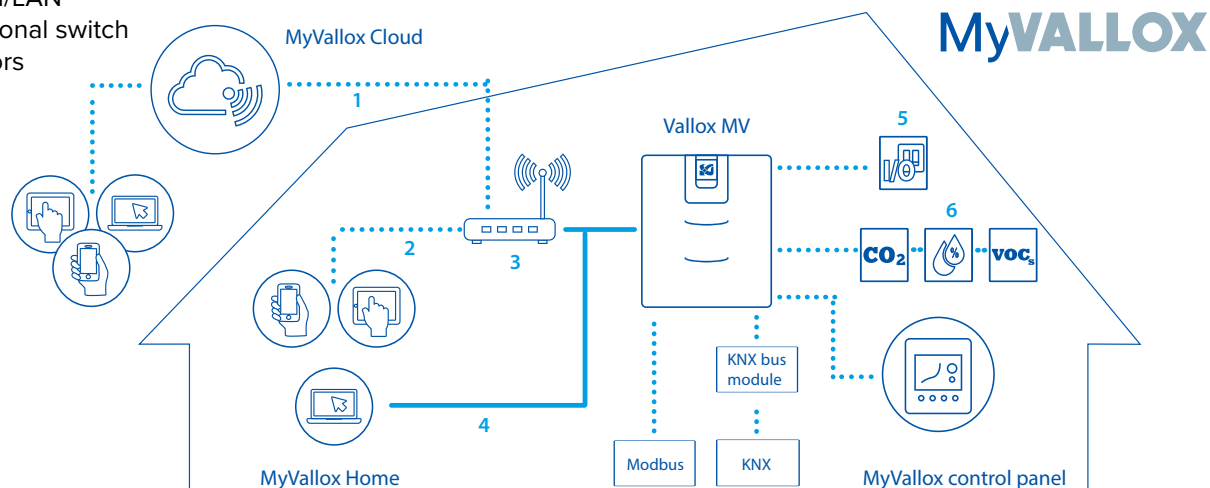

VENTILATION UNIT CONTROL

Ventilation unit control options

Operation of the Vallox ventilation unit can be controlled by the following means:

- Through a MyVallox control panel installed in the building.
- Through the MyVallox Home local area network connection and the MyVallox Home/Cloud user interface.
- Through the MyVallox Cloud service and the MyVallox Home/Cloud user interface.
- Through a remote monitoring service or building automation that uses voltage signals or Modbus messages.

In addition to the integrated humidity and carbon dioxide sensor, ventilation can also be adjusted automatically by using the optional carbon dioxide, humidity, or VOC (air quality) sensor. When these are used, ventilation remains optimal even when the dwelling is unoccupied. Each user can use the week clock to adjust the ventilation to fit their individual lifestyle.

The ventilation unit's integrated humidity and carbon dioxide sensors adjust ventilation automatically according to the need. In addition, ventilation can be automated by using optional carbon dioxide, humidity or air quality (VOC) sensors.

Filter reminder

The unit reminds of the need to change filters in the popup window of the compatible MyVallox control panel, in the MyVallox Home/Cloud user interface and by changing the relay status, provided that a signal light has been connected to the relay connectors and Maintenance reminder has been chosen as the relay setting.

The filter reminder can be acknowledged by the following means:

- **from the MyVallox control panel**
- **from the MyVallox Home/Cloud user interface**
- **with the Vallox Delico PTD EC and Vallox Capto PTC EC cooker hoods** — Push the **damper position** button four times at less than one second intervals, starting from the Damper closed position.

Ventilation unit setup without a control panel

The ventilation unit setup can also be completed without a control panel. For instructions, please go to <https://vallox.techmanuals.info/ValloxMV/ENG/help/webhelp>

See instructions provided in the section Connecting the ventilation unit to the computer.

Connecting the ventilation unit to the cloud service

The ventilation unit can be connected to the MyVallox Cloud service. The cloud service allows for controlling ventilation remotely also, using e.g. a smartphone or tablet. Also the unit software is updated automatically through the cloud service. To connect to the cloud service, the ventilation unit must be connected to the Internet via LAN and registered with the cloud service. At the same time you create a MyVallox Cloud account for yourself. Read more about the service at www.myvallox.com.



NOTE

For the MyVallox Cloud/Home instructions, please go to vallox.techmanuals.info/ValloxMV/ENG/help/webhelp



IMPORTANT

Prolonged overpressure can result in damage to the structures of the building.



IMPORTANT

Apartment-specific ventilation units allows residents to adjust the ventilation efficiency. Ventilation is controlled based on the need e.g. through the cooker hood, ventilation control panel, or a separate control centre. In order to ensure that the indoor air presents no harm to health and remains optimal also for the structures of the building, **ventilation must be kept on without disruptions**. It is recommended that ventilation be left turned on during long holidays also. This keeps the indoor air fresh and prevents humidity from condensing in the ventilation ducts and structures. It also reduces the risk of moisture damage.

MAIN PARTS

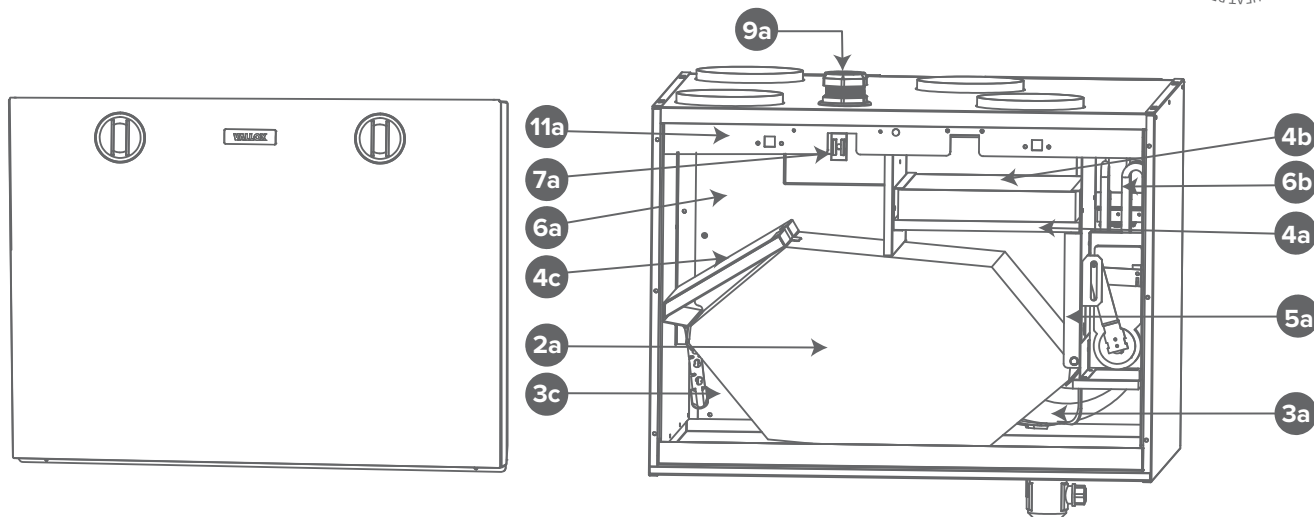

R model in the figure.
In the L model, the parts are mirrored

- | | | | | | |
|---|--|----|---|------------------------------------|------------|
|  | Heat recovery cell | 2a |  | Safety switch | 7a |
|  | Extract air fan | 3a |  | Ceiling bushing for electric wires | 9a |
|  | Supply air fan | 3c |  | Control panel | 10a
10b |
|  | Fine filter for supply air | 4a |  | Internal humidity sensor | 11a |
|  | Coarse filter for supply air | 4b |  | Internal carbon dioxide sensor | 11a |
|  | Coarse filter for extract air | 4c |  | Carbon dioxide sensor (optional) | 11c |
|  | Bypass damper of the HR cell | 5a |  | Humidity sensor (optional) | 11d |
|  | Post-heating resistor
(behind the extract air duct) | 6a |  | VOC sensor (Optional) | 11e |
|  | Additional heating resistor | 6b | | | |

MOUNTING ON THE WALL



NOTE

Avoid mounting the unit on a hollow, echoing partition wall or on a bedroom wall, or prevent the conduction of sound.

The minimum distance between the top of the unit and the finished ceiling surface is 30 mm. Note that during mounting the unit rises 10 mm higher than the final height.

Mount the ventilation unit onto the wall with a mounting plate (optional), as shown in the figures below. Make sure that the unit is horizontally level after mounting.

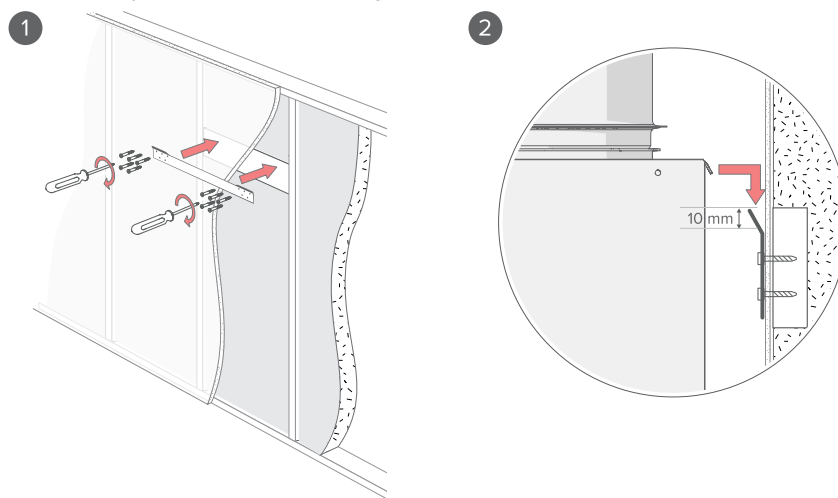

NOTE

When installing the unit, reserve a space of at least 500 mm in front of the unit for servicing purposes.



NOTE

Mount the ventilation unit in a place where the temperature does not fall below +10°C.

MOUNTING ON THE CEILING

Vallox 99 MV can be equipped with an optional ceiling mounting plate. To attach the ceiling mounting plate:

- On rafter frames or other frame structure with M8 thread bars so that they withstand the weight of the unit.
- Ensure that the installation plate is horizontally level, as this determines the position of the unit.
- The top edge of the white covering strip of the ceiling mounting plate can be installed against the ceiling. Alternatively, a concealed mounting method can be used, in which case the ceiling can be 30 mm below the top of the white covering strip.

Insulate the ducts against condensation also between the unit and the ceiling mounting plate.

Mounting the ceiling mounting plate

1. Fasten the thread bars on the rafter frames or other frame structure, and screw the nuts (E) onto the bars.
2. Lift the ceiling mounting plate in place.
3. Push a rubber damper (F) and a washer (G) to each thread bar.
4. Adjust the nuts so that the ceiling mounting plate is level.
5. Shorten the lower ends of the thread bars so that they are no more than 5 mm below the nuts.



CAUTION

The ventilation unit is very heavy. Do not perform this procedure alone.

Installing the ventilation unit to the ceiling mounting plate

1. Install the ceiling mounting plate with M8 thread bars so that it is horizontally level.



NOTE

The end of the thread bars must be 5 mm or less below the fastening nut. Do not fasten the ceiling mounting plate too tight to the ceiling. Ensure that the sliding bars move and restore to their original position by pulling from the operating levers (A).

The top edge of the white covering strip of the ceiling mounting plate can be installed against the ceiling. Alternatively, a concealed mounting method can be used, in which case the ceiling can be 30 mm below the top of the white covering strip.

2. Ensure that the insulation washers are in the outlet collars below the ceiling mounting plate.
3. Remove the door before installing the ventilation unit to the ceiling mounting plate.
4. Lift the ventilation unit close to the ceiling mounting plate and feed the cables and the connection box through the hole in the ceiling mounting plate on top of the ceiling.



NOTE

Remember to make a service door in the ceiling so that the cables and the connection box can be accessed. The distance between the service door and the ceiling mounting plate must be around 500 mm.

Alternatively, the cables can be fed to the rear wall between the ceiling mounting plate and the ventilation unit. When the ventilation unit is lifted against the ceiling mounting plate, the unit locks in place. Where needed, guide the mounting hooks on the ceiling mounting plate (B) to the grooves on the side panels of the ventilation unit.

There are operating levers (A) on the front bottom corners of the ceiling mounting plate. When the levers have been restored to the same level with the white covering strip of the ceiling mounting plate, the unit has been locked in place.

5. Where required, the unit can be detached from the ceiling mounting plate. Remove the door of the unit. Lift the unit slightly upwards and pull simultaneously from both operating levers (A) of the ceiling mounting plate to detach the unit from the ceiling mounting plate.

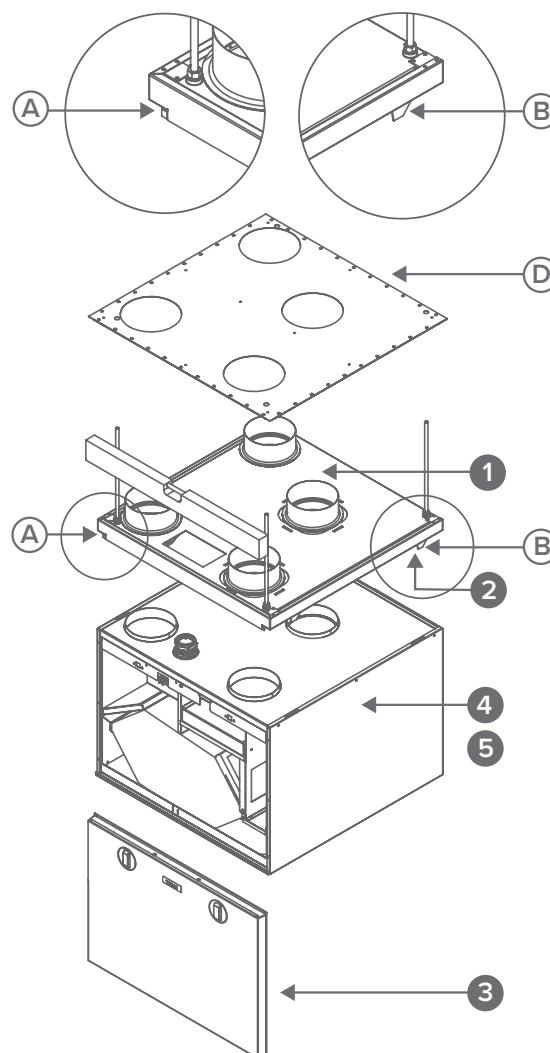

Attic floor penetration plate

The attic floor penetration plate (D) is optional. When an attic floor penetration plate is used, the tightness of the vapour barrier has to be ensured.

The attic floor penetration plate can be fastened on the finished rear wall. The minimum distance of the attic floor penetration plate from the finished side walls is 15 mm.

REMOVAL OF CONDENSING WATER

Dimensioning figures and space required for installation of the Vallox Silent Klick siphon

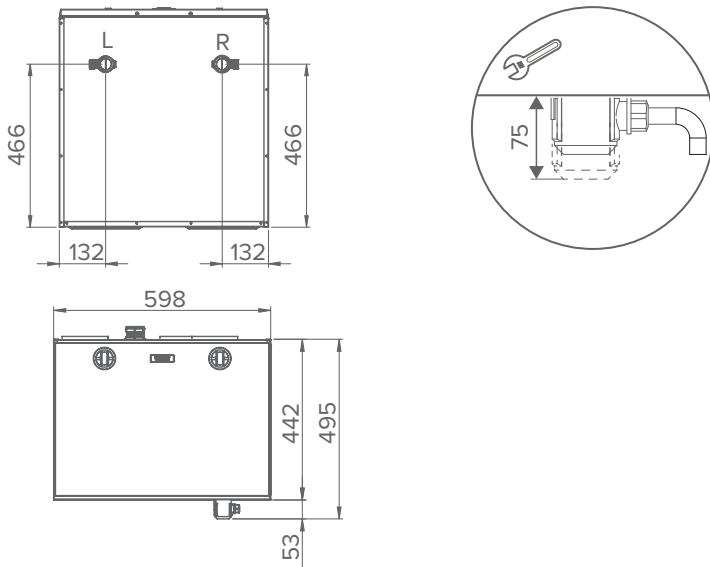

NOTE

The Vallox Silent Klick siphon package is delivered with the unit. Installation instructions for the siphon are enclosed with the packaging, and can also be found online at www.vallox.com. When the alternative siphon installation method is used, the ring seal and the locking part must be moved to the pipe connection part that is mounted on the wall.

Space required by the alternative Vallox Silent Klick siphon installation method (elbow)

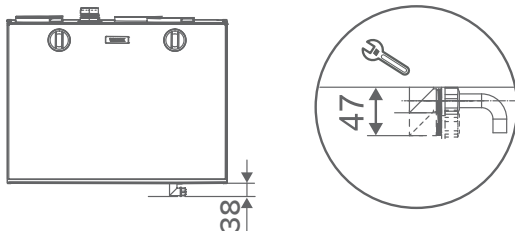

MEASURING AND ADJUSTING THE AIR FLOWS OF THE VENTILATION UNIT

The accessories delivered with the unit include four (4) air flow measuring tubes. These can be inserted in the ducts to allow for easier ventilation adjustment.

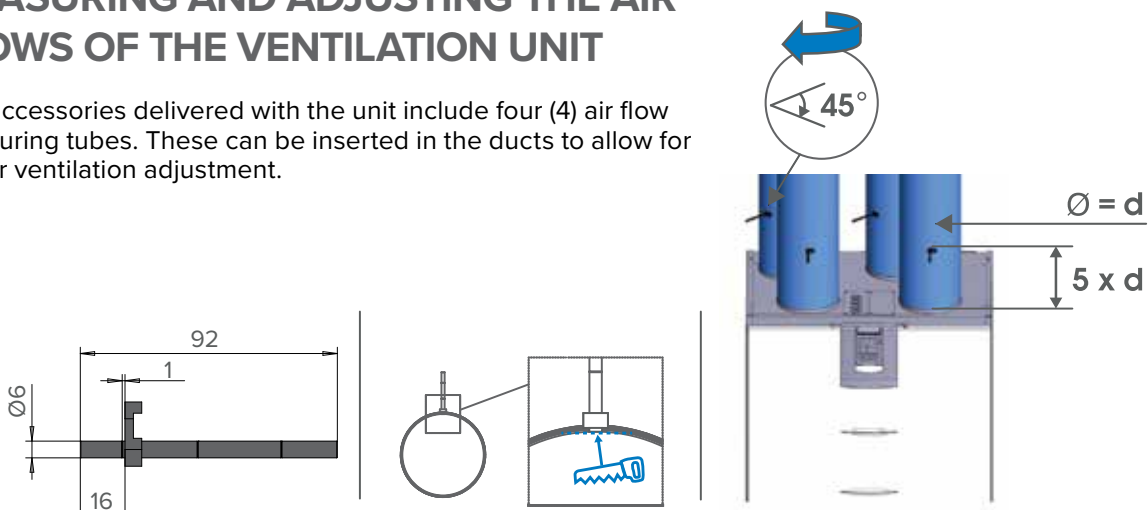

DIMENSIONS AND DUCT OUTLETS

Main parts

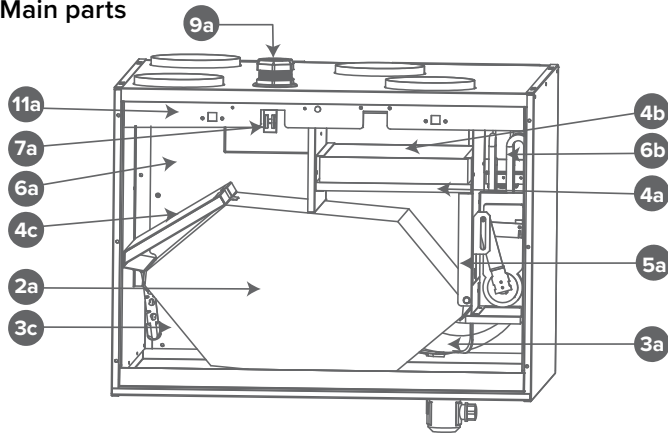

R model in the figure.
In the L model, the parts are mirrored

- 2a Heat recovery cell
- 3a Extract air fan
- 3c Supply air fan
- 4a Fine filter for supply air
- 4b Coarse filter for supply air
- 4c Coarse filter for extract air
- 5a Bypass damper of the HR cell
- 6a Post-heating resistor
- 6b Additional heating resistor
- 7a Safety switch
- 9a Ceiling bushing for electric wires
- 11a Internal humidity sensor
- 11a Internal carbon dioxide sensor

Air flow measurement points

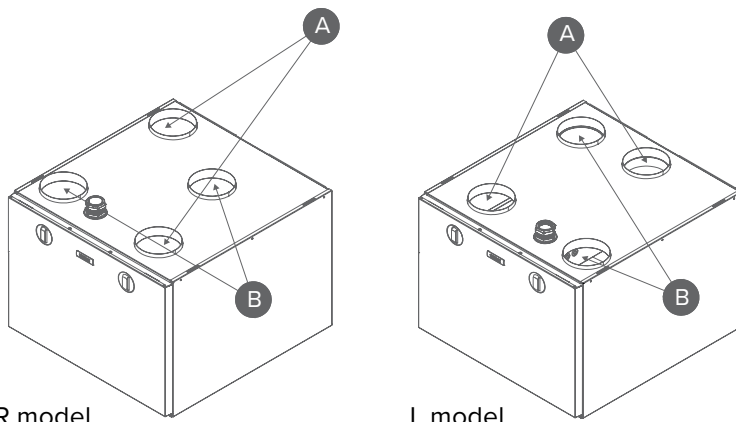

R model

L model

1. A Supply air
2. B Extract air

Measurement points after the outlet collar. The fan curves indicate the total pressure accounted for by duct losses.

Dimensions and duct outlets

Dimensions

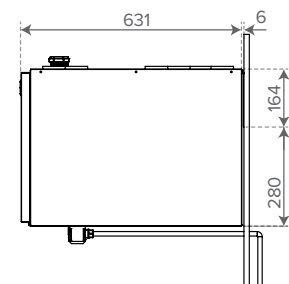
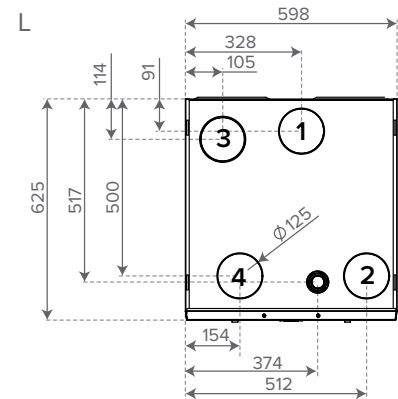
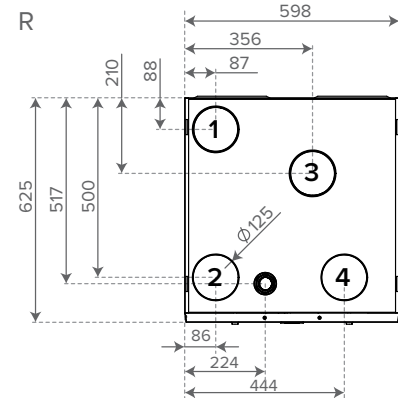
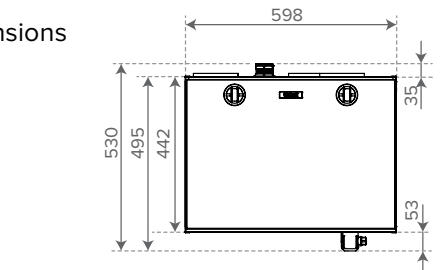

Duct outlets

Inner diameter of the female collar: 125mm

1. Supply air from the unit to the apartment
2. Extract air from the apartment to the unit
3. Exhaust air flowing outdoors from the unit
4. Outdoor air to the unit

BEFORE BEGINNING MAINTENANCE WORK

The safety switch (S) automatically turns off the power when the door of the unit is opened.

WARNING
Always disconnect the power plug before starting the ventilation unit maintenance.

There are two unit models, left- (L) and right-handed (R). The figure shows the right-handed model.



IMPORTANT

If the power cord is damaged, the manufacturer, its service representative or other person with similar qualifications must replace it to avoid danger.

REPLACING THE FILTERS

When the maintenance reminder becomes activated, check the cleanliness of the filters and replace them if required.

The Vallox ventilation unit has three air filters:

- Coarse filter for supply air filters insects, heavy pollen and other relatively large foreign objects out of the outdoor air.
- Fine filter for supply air filters microscopic pollen and dust particles out of the supply air.
- Coarse filter for extract air filters the extract air and keeps the heat recovery cell clean.

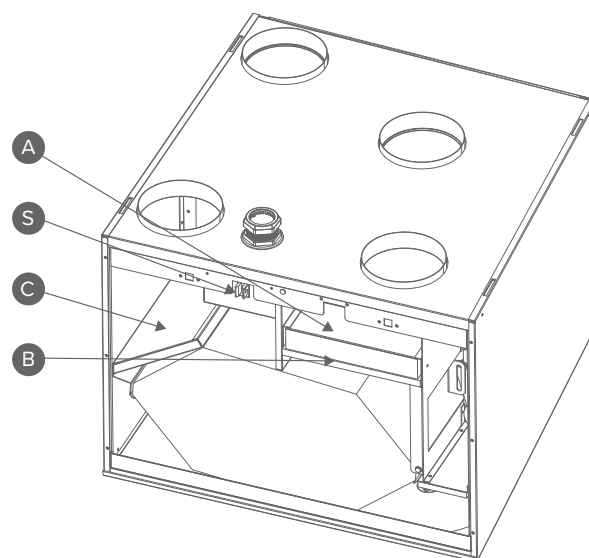

The filter replacement interval depends on the ambient particle concentration. It is recommended that the filters be replaced every spring and autumn, or, at the very least, once a year.

To replace the filters:

1. Disconnect the ventilation unit from the mains electricity supply.
2. Open the door of the Vallox ventilation unit by undoing the finger screws.
3. Lift the door off.
4. Remove the old filters (A, B, C) and discard them.

CAUTION
The door is heavy.

5. Install the new filters (A, B, C).
6. Close the door of the unit. Ensure that the safety switch catch of the door is touching the safety switch, allowing the unit to be turned on.
7. Plug the ventilation unit back into the mains.

The filters have now been successfully replaced.



NOTE

The service space in front of the ventilation unit must be at least 500 mm.



TIP

Using original Vallox filters ensures that the ventilation unit remains in top condition, giving the best results. To select and order filter packages, please go to: filters.vallox.com

CLEANING THE HEAT RECOVERY CELL

Check that the heat recovery cell is clean roughly once a year, or whenever the filters are being replaced. Clean by washing as required.

To check and clean the heat recovery cell:

1. Disconnect the ventilation unit from the mains electricity supply.
2. Open the door of the Vallox ventilation unit by undoing the finger screws.
3. Lift the door off.



CAUTION

The door is heavy.

4. Remove the supply air filter (A).
5. Turn the upper support of the HR cell (B) to the upper position (anti-clockwise).
6. Remove the extract air filter (C).
7. Lift and pull the HR cell (D) out of the unit.
8. If the cell is dirty, clean it by immersing it in warm water, to which a small amount of a mild detergent has been added.
9. Rinse the cell clean with a water spray. Do not use a high-pressure cleaner.
10. When all the water has drained from between the layers, reassemble the ventilation unit as follows:
11. Ensure that the lower support (E) is in place against the knobs at the bottom of the unit.
12. Lift the HR cell in place.
13. Turn the upper support against the cell. Ensure that the upper support is properly nestled against the cell (remains upright).
14. Install the extract air filter (C) and the supply air filters (A) in place.
15. Close the door. Ensure that the safety switch catch of the door is touching the safety switch.
16. Plug the ventilation unit back into the mains.

The heat recovery cell has now been checked and cleaned.



IMPORTANT

Handle the cell carefully! For example, do not lift the cell by the layers. The cell layers are very thin and easily damaged.

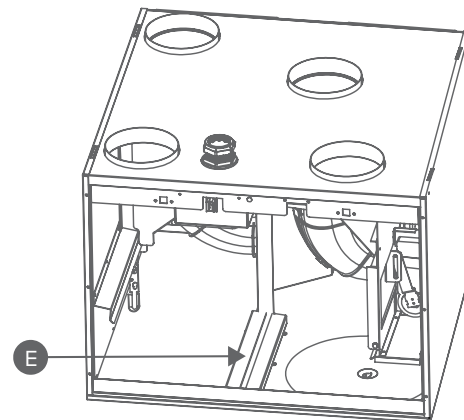
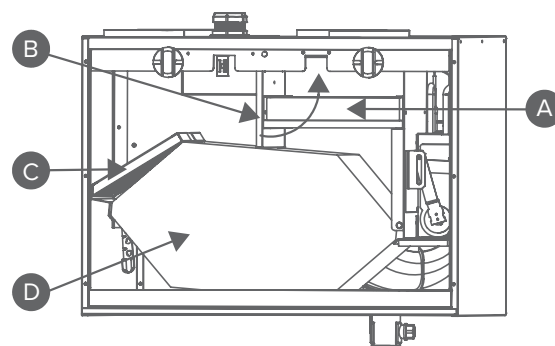

CONDENSING WATER

In the heating season, the extract air humidity condenses to water. In new buildings, the volume of condensing water can be high. Condensed water must be able to freely leave the unit.

At some time before the heating season begins (e.g. during autumn maintenance), check that the siphon or the condensing water outlet in the bottom pool are not clogged. To check this, pour some water into the pool. Clean as required.



NOTE

Some condensing water may have accumulated in the bottom pool of the unit; this is normal and requires no corrective action.



WARNING

Water must at all times be kept out of the electrical system.

CLEANING THE FANS

Check the cleanliness of the fans when servicing the filters and the heat recovery cell. Clean the fans as required.

You can clean the fan blades with compressed air (wear protective goggles) or by brushing them gently. Do not remove or move the fan blade balancing weights.

To clean the fan:

1. Disconnect the ventilation unit from the mains electricity supply.
2. Open the door of the Vallox ventilation unit by undoing the finger screws.
3. Lift the door off.



CAUTION
The door is heavy.

4. Remove the supply air filters (A) and the extract air filter and turn the upper support of the cell (B) anti-clockwise against the ceiling. See chapters “Replacing the filters” and “Cleaning the heat recovery cell”.
5. Remove the support plate (F) by undoing the screws (E).
6. Push the wires of the fan and the rubber feedthrough (K/L) through the intermediate floor and to the bottom part of the unit.
7. Remove the plastic screws used to fasten the fans (I) (2 per fan). Remove the wing screws (J) (2 pcs) of the post-heating resistor (only when changing the supply air fan) and remove the cable of the resistor (G) from the connector.
8. Remove the fan from the unit by lowering it before turning the fan anti-clockwise, whilst tilting it. Remove the control grille by undoing the screws (4 pcs).
9. You can now clean the fan. Put the control grille (S) back in place after cleaning.
10. Reassemble in reverse order after cleaning. Once the fan has been installed, ensure that the rubber feedthroughs (M, K, L) are in place.
11. Close the door. Ensure that the safety switch catch of the door is touching the safety switch.
12. Plug the ventilation unit back into the mains.

The fan has now been checked and cleaned.

If the power cord is damaged, it must be replaced by the manufacturer, its service agent, or a similarly qualified person in order to avoid a hazard.

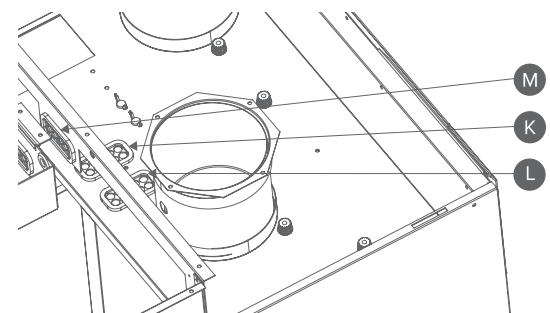
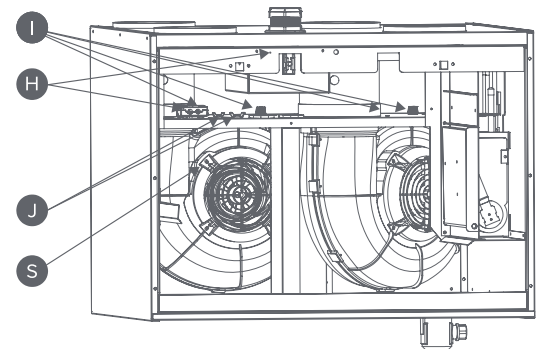
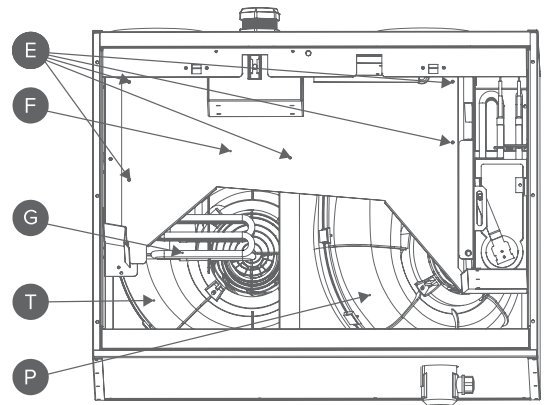
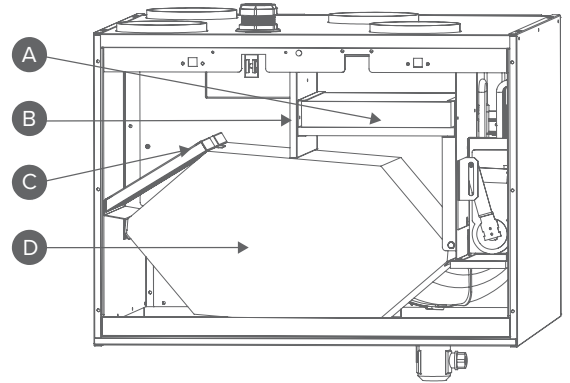

TECHNICAL SPECIFICATIONS

Product title	Vallox 99 MV R Vallox 99 MV L		
Air volumes Supply air Extract air	92 dm ³ /s, 100 Pa 99 dm ³ /s, 100 Pa	Fans Supply air Extract air	0.085 kW, 0.75 A EC 0.085 kW, 0.75 A EC
Post-heating	Electrical resistor, 900 W	Electrical connection	230 V, 50 Hz, 8.6 A power plug
Pre-heating	–	Enclosure protection class	IP 34
Additional heating	Electrical resistor, 900 W	Heat recovery bypass	Automatic
Filters Supply air Extract air	ISO Coarse > 75% + ISO ePM ₁ ≥ 50% ISO Coarse > 75%		
Specific energy consumption (SEC) in a cold climate in a temperate climate	A+ A	Operating efficiencies* Annual efficiency Supply air efficiency Specific Fan Power (SFP)	76% 81% 1.12 kW/m ³ /s (64 dm ³ /s)
Dimensions (w x h x d)	598 x 442 x 625 mm	Weight	62 kg

*Working point defined in the Ecodesign Directive (2009/125/EC), Southern Finland, Helsinki-Vantaa TRY year 2020.

FAN INPUT POWER

SUPPLY/EXTRACT AIR VOLUMES

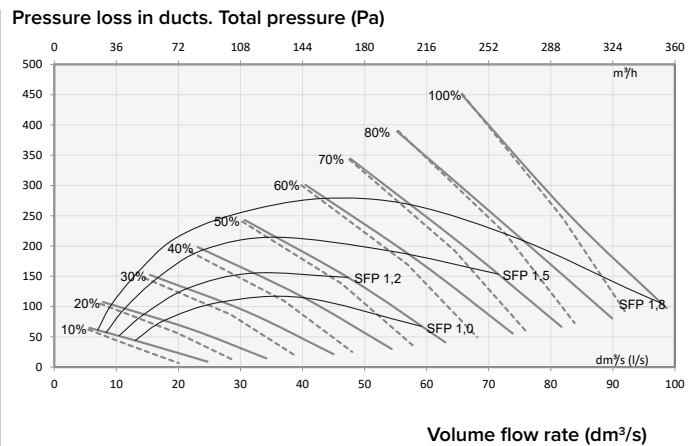
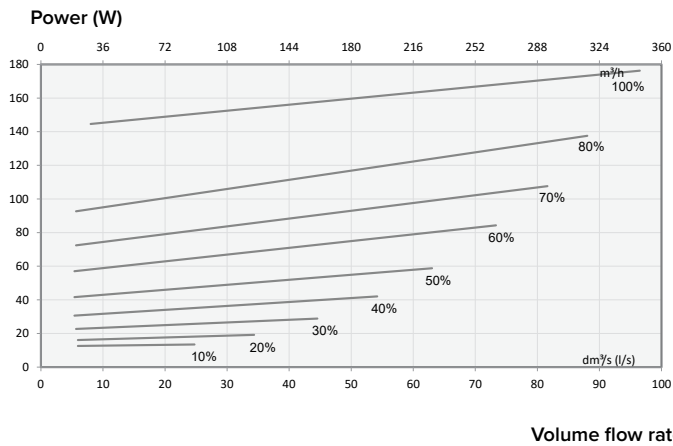

$$SFP = \frac{\text{Input power (total) (W)}}{\text{Air flow (max) (dm}^3\text{/s)}}$$

SFP rate (Specific Fan Power)
recommended value <1.8 (kW m³/s)

— — — — — extract air
- - - - - supply air

SOUND VALUES

		Sound power level in the supply air duct (one duct) by octave band L _w , dB Adjustment position									Sound power level in the extract air duct (one duct) by octave band L _w , dB Adjustment position										
Adjustment position (%)		10	20	30	40	50	60	70	80	90	100	10	20	30	40	50	60	70	80	90	100
Medium frequency of the octave band Hz	63	62	62	65	66	70	71	73	74	77	79	53	52	56	62	65	69	71	71	73	74
	125	52	55	57	59	62	63	65	66	68	68	43	46	49	52	55	59	62	65	66	67
	250	52	58	61	64	68	66	67	68	69	70	35	41	54	47	50	52	54	56	57	58
	500	47	52	56	60	63	79	72	81	76	75	24	30	35	39	43	48	50	52	57	53
	1000	39	45	50	54	58	61	63	64	66	67	20	26	31	35	38	41	44	46	48	49
	2000	27	36	43	48	52	55	57	59	62	62	13	15	20	24	27	31	33	36	38	38
	4000	19	26	35	41	45	50	52	54	56	57	17	17	17	18	20	23	26	28	30	31
8000	21	21	23	28	33	39	43	46	48	49	21	21	21	21	21	21	22	22	23	24	
L _w , dB		63	64	67	70	73	80	77	82	80	81	53	53	59	62	66	69	72	72	74	76
L _{WA} , dB(A)		48	53	57	61	64	76	71	78	75	74	33	36	46	43	47	50	52	55	57	57
Sound pressure level coming through the envelope of the unit in the room in which it is installed (10m ² sound absorption)																					
Adjustment position																					
Adjustment position (%)		10	20	30	40	50	60	70	80	90	100										
L _{pA} , dB (A)		22	25	28	32	34	36	38	43	41	41										

You can calculate the sound values for each operating point with the Vallox MySelecta software.

INTERNAL ELECTRICAL CONNECTION

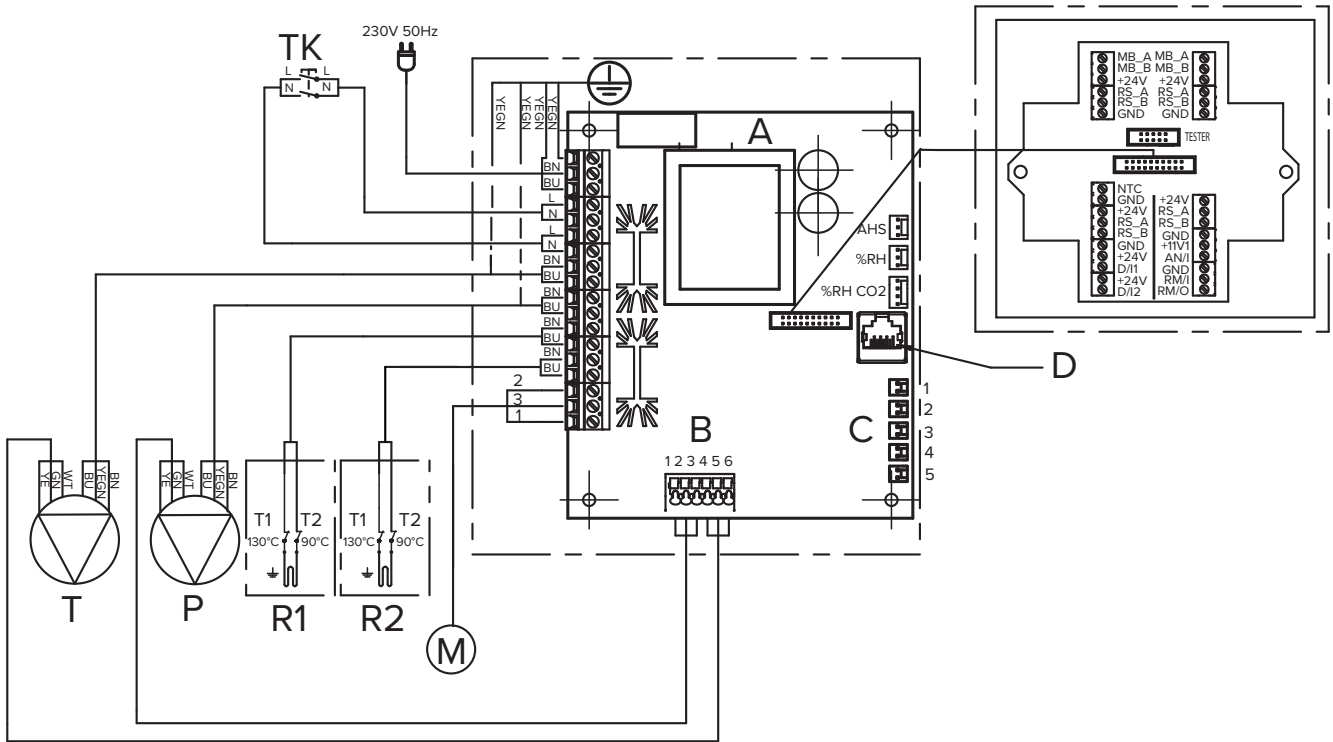

A	Motherboard	MB_A	External Modbus A signal	T	Supply air fan
B	1. Extract air fan tachometer (WT) 2. GND (GN) 3. Extract air fan PWM (YE)	MB_B	External Modbus B signal	P	Extract air fan
C	1. Extract air 2. Outdoor air 3. Supply air 4. Exhaust air 5. Supply air from the HR cell	+24V	+24V voltage (DC)	M	Damper motor
D	LAN	GND	Digital and analog ground potential	TK	Safety switch
		RS_A	Local hardware Modbus A signal	AHS	Post-heating control
		RS_B	Local hardware Modbus B signal	%RH	Internal humidity sensor
		NTC	External temperature sensor connector	%RH CO₂	Internal humidity and carbon dioxide sensor
		D/I1	Digital input 1	R1	Post-heating resistor with 90°C and 130°C overheating protection
		D/I2	Digital input 2	R2	Post-heating resistor with 90°C and 130°C overheating protection
		11V1	11.1 V operating voltage		
		AN/I	Analog input 0-10VDC		
		RM/I	24V relay input		
		RM/O	24V relay output		

CABLE COLOURS

BK	Black
BU	Blue
BN	Brown
WT	White
GY	Grey
YE	Yellow
YEGN	Yellow-green

EXTERNAL ELECTRICAL CONNECTION

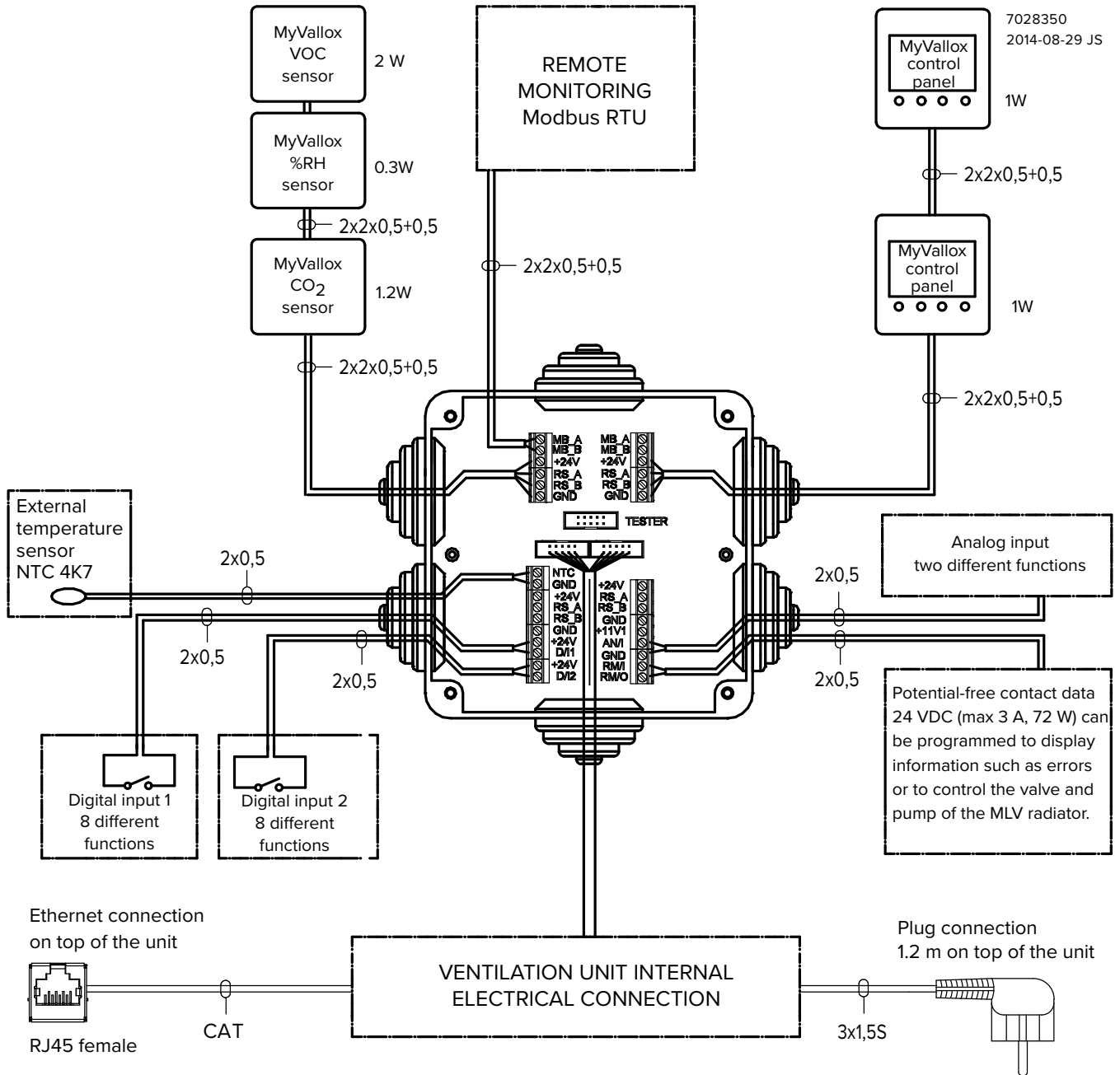

7028350
2014-08-29 JS

1W

1W

Potential-free contact data
24 VDC (max 3 A, 72 W) can
be programmed to display
information such as errors
or to control the valve and
pump of the MLV radiator.

POWER SUPPLY	
Maximum	≤6 W
MyVallox Control	1 W
MyVallox Touch	0.5 W
MyVallox %RH sensor	0.3 W
MyVallox CO ₂ sensor	1.2 W
MyVallox VOC sensor	2 W
External actuator or damper motor of the unit that receives feed from the relay	
Voltage	24 VDC

MB_A	External Modbus A signal
MB_B	External Modbus B signal
+24V	+24V voltage (DC)
GND	Digital and analog ground potential
RS_A	Local hardware Modbus A signal
RS_B	Local hardware Modbus B signal
NTC	External temperature sensor connector

D/I1	Digital input 1
D/I2	Digital input 2
11V1	11.1 V operating voltage
AN/I	Analog input 0-10 VDC
RM/I	24V relay input
RM/O	24V relay output

EXTERNAL ELECTRICAL CONNECTION FOR CONTROLLING THE MLV DUCT RADIATOR

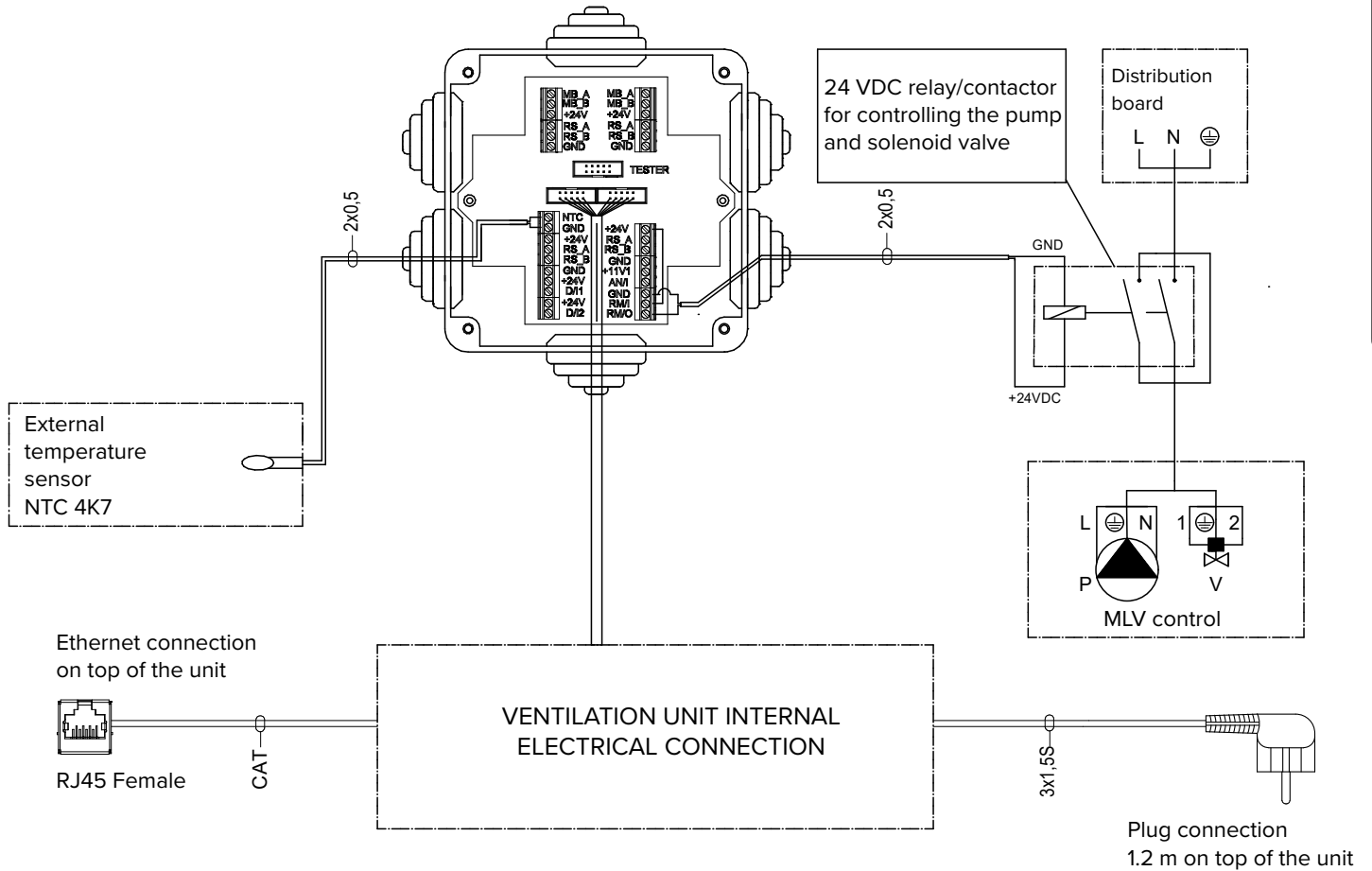

MB_A	External Modbus A signal
MB_B	External Modbus B signal
+24V	+24V voltage (DC)
GND	Digital and analog ground potential
RS_A	Local hardware Modbus A signal
RS_B	Local hardware Modbus B signal
NTC	External temperature sensor connector
D/I1	Digital input 1

D/I2	Digital input 2
11V1	11.1 V operating voltage
AN/I	Analog input 0-10VDC
RM/I	24V relay input
RM/O	24V relay output
P	Circulation pump
V	Solenoid valve

DUCT RADIATOR OPERATION

Always follow first and foremost the connection diagram provided by the HVAC designer or heat pump manufacturer. Also read the duct radiator manual.

The accompanying figure shows an example of the arrangement for connecting the heating/cooling radiator unit to the heat collection circuit.

Connect the radiator output pipe to the heat collection circuit return pipe. Direct the fluid returning from the radiator unit to the heat collection circuit return pipe. If you know that there is a large loss of internal pressure inside the heat pump, the heat pump should be bypassed. If this is done, the fluid circuit will come into operation when the heat pump comes to a halt. When this happens the pressure loss in the one-way bypass valve Y2 must be lower than the pressure loss in the heat pump.

Heating: The pump starts when the outdoor air temperature drops below the winter limit value set at the factory (-5 °C).

Cooling The supply air setpoint value for the active mode (for example, At home) controls the pump start-up. The pump starts when the supply air setting is below the temperature of the supply air that is blown into the apartment.

The duct radiator can be installed in both the supply air duct and the outdoor air duct. If the radiator is installed in the outdoor air duct, it can be used for both preheating and cooling. If the radiator is installed in the supply air duct, it can be used for heating or for cooling only.

The duct radiator can be set to function either automatically or manually.

- **Automatic** - In summer, the supply air temperature will be maintained at the level specified in the temperature setting. In winter, the duct radiator will turn on, when the outdoor temperature falls below the winter setting.
- **Manual** - In summer, the duct radiator will turn on, when the outdoor temperature rises above the summer setting. In winter, the duct radiator will turn on, when the outdoor temperature falls below the winter setting.

To prevent the risk of condensation in the supply air duct, you can set the adjustment of the supply air limit to automatic or manual.

- **Automatic** - The supply air limit is adjusted automatically based on the dew point of the extract air. When the supply air temperature falls too low, the duct radiator will turn off.
- **Manual** - The supply air limit can be set manually. When the supply air temperature falls down to the set value, the duct radiator will turn off.

If an external sensor is in use, it is selected from the settings of the external sensor whether it is used to control the outdoor air duct radiator or the supply air duct radiator. The temperature of the external sensor can be read from the service menu: **menu** > **service menu** > unit information page 5 "External sensor".



NOTE: If the duct radiator is used in the supply air duct, it can only be used for cooling.



NOTE: When used to control the outdoor air duct radiator, the external NTC sensor is installed in the outdoor air duct before the radiator. When used to control the supply air duct radiator, the external NTC sensor is installed after the radiator.



NOTE: When selecting the relay (C), take account of the maximum allowed combined power supply (6W) of the circuit board in the external MV electrical box, if the relay power supply comes from the circuit board's +24V connector.



NOTE: Due to the risk of humidity damage, in a duct that has not been insulated for condensation the supply air temperature must not fall below +16 ... 20 °C.

DUCT RADIATOR OPERATION CHART

In the outdoor air duct

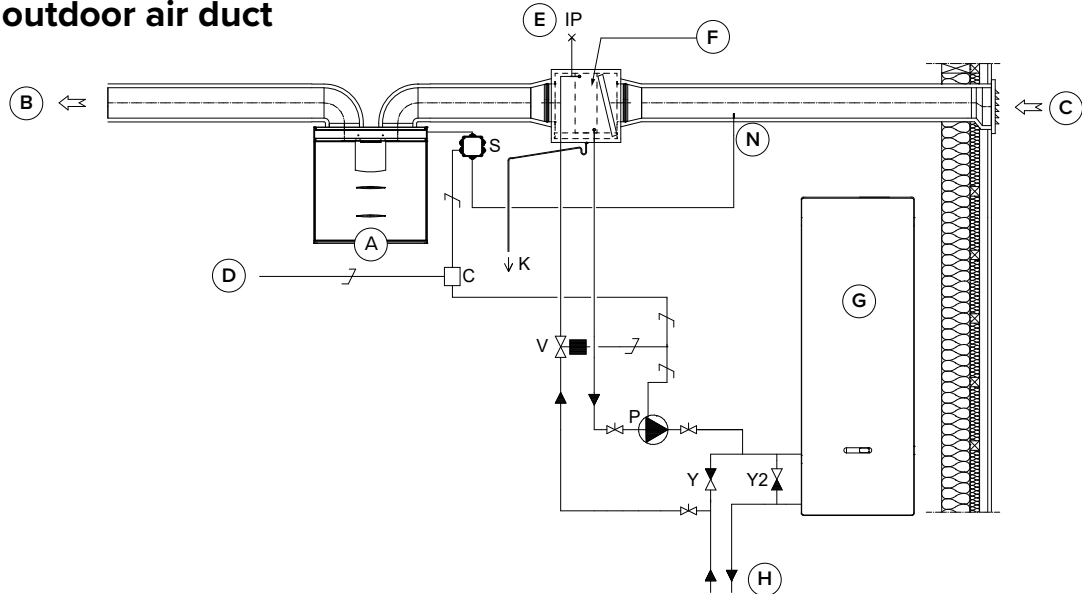

In the supply air duct

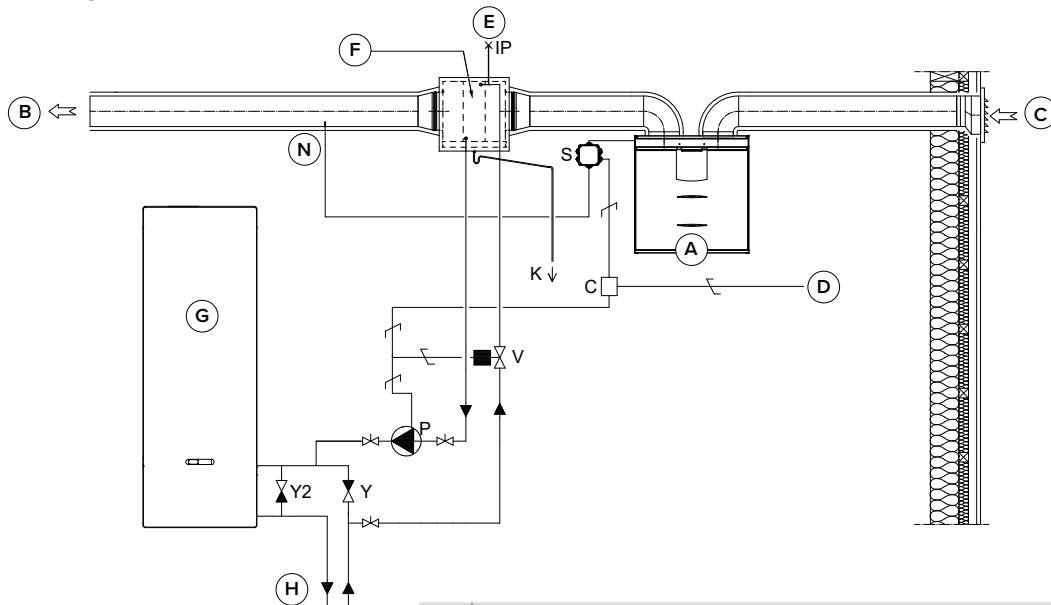

A	Ventilation unit
B	Supply air
C	Outdoor air
D	Feed from the distribution board
E	Air extraction
F	Duct radiator (reverse connection)
G	Heat pump
H	Heat collection circuit
N	External NTC sensor

P	Circulation pump. Not included in the delivery. The pump should be suited to pumping liquid colder than the surrounding air, due to risk of condensation (for example, Grundfos Magna 125-80).
V	Solenoid valve. Not included in the delivery. The valve that is chosen must be compatible with the heat collection circuit fluid (for example, Danfos 032U161431)
K	Condensing water tube. Not included in the delivery.
IP	De-aerator. Not included in the delivery.
S	External electrical junction box for the MV
N	External NTC sensor for Vallox MV ventilation units
C	24 VDC relay/contactors for controlling the pump and the solenoid valve. Not included in the delivery. (For example, ABB CR-P024DC2)
Y	One-way valve. Not included in the delivery.
Y2	One-way valve. Not included in the delivery. The pressure loss must be less than the pressure loss of the heat pump.

EXPLODED VIEW AND SPARE PARTS LIST

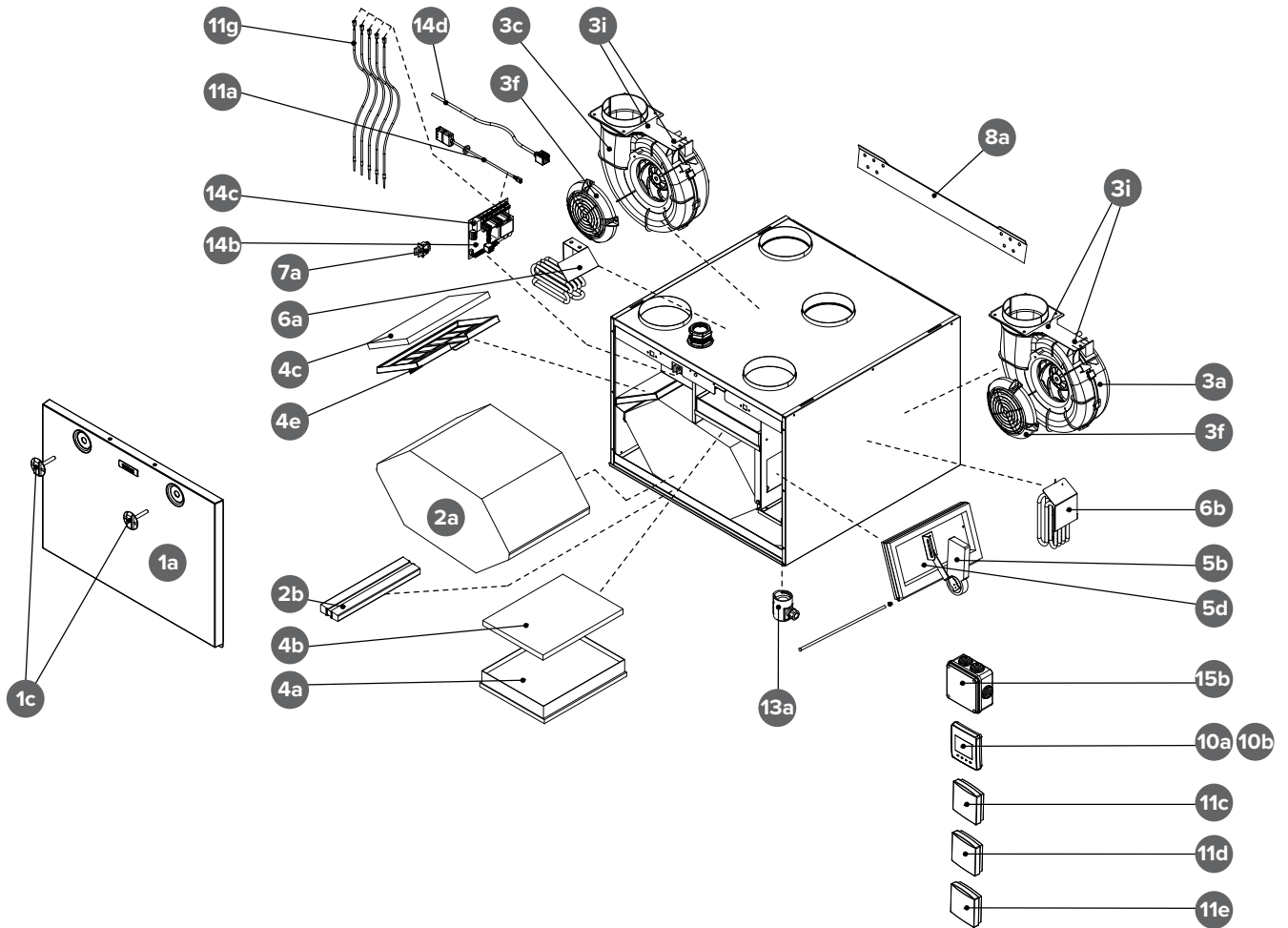

NO.	PART	PRODUCT NO.	NO.	PART	PRODUCT NO.	NO.	PART	PRODUCT NO.
1a	Door	4116174	4e	Extract air filter frame	4114315	11c	MyVallox carbon dioxide sensor (optional)	949111
1c	Mounting screw of the door	990712	5b	Bypass damper motor	930621	11d	MyVallox humidity sensor (optional)	946149
2a	HR cell	933220	5d	HR cell bypass damper assembly	4115315	11e	MyVallox VOC sensor (optional)	949112
2b	Lower support for HR cell	4114303	6a	Post-heating resistor	4115413	11g	NTC sensor kit	4115613
3a	Extract air fan with a hood	4114496	6b	Additional heating resistor	4115412	13a	Siphon Vallox Silent Klick	3494701
3c	Supply air fan with a hood	4114496	7a	Safety switch	948377	14b	Motherboard	949032-1
3f	Air flow control grille	4114497	8a	Wall mounting plate (optional)	3080700	14c	Glass tube fuse 63mA slow 5x20mm	952490
3i	Plastic screw Vallox 99	950308	8a	Wall mounting plate (optional)	3080700	14d	RJ45 extension cable	952196
4a	Fine filter for supply air	4114075	10a	MyVallox Control panel	949033	15b	Connection box	3526700
4b	Coarse filter for supply air	4114075	10b	MyVallox Touch control panel	949090			
4c	Coarse filter for extract air	4114459	11a	Internal humidity and carbon dioxide sensor	4107982			

DECLARATION OF CONFORMITY

Manufacturer Vallox Oy

Address Myllykyläntie 9-11, FIN-32200 LOIMAA, FINLAND

Telephone number +358 10 7732 200

Fax +358 10 7732 201

The person who compiles the technical file Petri Koivunen
Vallox Oy
Myllykyläntie 9-11, FIN-32200 LOIMAA, FINLAND
Tel. +358 10 7732 234
Fax +358 10 7732 201
Email petri.koivunen@vallox.com

Description of unit Ventilation unit with heat recovery

Model Vallox 121 SE,
Vallox 51/51K SC/MV,
Vallox 99/101/125/096/110/145/245/245 VKL MV,
Vallox TSK Multi 50/80 MV,
ValloPlus 180/180K/270/350/370/510/850 MV,
ValloPlus 180/270/350/510 SC,
ValloMulti 200/300 SC/MV

Declares that the ventilation unit for supply and extract air, equipped with heat recovery and operating as part of a ventilation system has been designed and manufactured to the following specifications:

1. Low Voltage Directive (2014/35/EU) – EN 60335-1:2012 + A11:2014, A13:2017 + A1:2919 + A14:2019 + A2:2019; EN 62233:2008
2. EMC Directive (2014/30/EU) – EN 61000-6-1:2007, EN 61000-3-2:2014 + A1:2009 + A2:2009, EN 61000-3-3:2013, EN 61000-6-3:2007 + A1:2011
3. Ecodesign Directive (2009/125/EY) – Commission regulation 1253/2014 – EN 13141-7 Annex B, EN 308, EN 13141-7, ISO 3741, ISO 5135

This is the original Declaration of Conformity

Loimaa, 7th August 2023



Jukka-Pekka Korja
Managing Director

VALLOX

www.vallox.com

Vallox Oy | Myllykyläntie 9-11 | 32200 LOIMAA | FINLAND

D10813/16.02.2024FIN/16.02.2024ENG/PDF