

**Model**

Vallox Pureo SR 550  
Vallox Pureo SR 1000  
Vallox Pureo SR 1500  
Vallox Pureo SR 2000  
Vallox Pureo SR 3000  
Vallox Pureo SR 4500

**Document**  
D12069**Valid from**  
01.01.2026**Updated**  
13.03.2026

## VALLOX Pureo SR

Manual

---



Air handling units

## CONTENTS

<b>INTRODUCTION</b> .....	<b>2</b>	<b>TECHNICAL SPECIFICATIONS</b> .....	<b>28</b>
Safety .....	3	Performance and technical specifications .....	28
Installation .....	3	Exploded view and parts lists .....	29
Warranty .....	3	Vallox Pureo SR .....	29
Intended purpose .....	3	Device connections .....	30
Disposal of the air handling unit .....	3	Declaration of conformity .....	34
Safety symbols .....	4		
Regulations – Instructions .....	4		
Scope of application – intended purpose .....	5		
Main parts .....	6		
Vallox Pureo SR 550–3000 .....	6		
Main parts .....	7		
Vallox Pureo SR 4500 .....	7		
Delivery contents .....	8		
Package dimensions and weight .....	8		
Storage .....	8		
Transport and moving .....	9		
Disassembly and reassembly .....	10		
<b>INSTALLATION</b> .....	<b>11</b>		
Mechanical assembly .....	11		
Assembly area .....	11		
Stabilisation .....	12		
Installation of door handles .....	12		
Changing the handedness of maintenance .....	13		
Switching the maintenance side of the rotary heat exchanger .....	13		
Switching the maintenance side of the post-heating radiator .....	13		
Changing the handedness of the outdoor air dampers .....	13		
Assembly of unit parts .....	14		
Flange connections and adapters .....	16		
Duct system .....	16		
Electrical connections .....	17		
Mains connections .....	18		
Controller connection .....	18		
Dimensions and duct outlets .....	19		
Vallox Pureo SR 550 .....	19		
Vallox Pureo SR 1000 .....	19		
Vallox Pureo SR 1500 .....	20		
Vallox Pureo SR 2000 .....	20		
Vallox Pureo SR 3000 .....	21		
Vallox Pureo SR 4500 .....	21		
<b>MAINTENANCE</b> .....	<b>22</b>		
Service and maintenance .....	22		
Maintenance plan .....	22		
Service and maintenance of the rotary heat exchanger .....	23		
Disassembly .....	23		
Cleaning .....	24		
Filter replacement .....	25		
Service and maintenance of fans .....	26		
Cleaning the unit .....	27		

## SAFETY

Safe and appropriate handling of the unit requires an understanding of the applicable basic safety regulations and the intended purpose of the ventilation system. Read this manual before using the air handling unit and keep it safe for later use. If you lose the manual, you can find and download it on our website.

This manual contains all the information needed for the safe use of the system. All persons using and maintaining the ventilation system shall follow the instructions in this manual. They must also comply with any local safety regulations to prevent accidents.

## Installation

The installation and setup of the unit shall be carried out by qualified professionals only. Electrical installations and electrical connections shall be done by an electrician in compliance with the local legislation.

## WARRANTY

The warranty and the manufacturer's responsibility do not cover damage caused by:

- Inappropriate use of the ventilation system or control unit
- Incorrect or inappropriate installation, setup or use of the unit
- Failure to comply with the instructions for transport, installation, use or maintenance
- Structural or electronic modifications, or changes made to the software

## INTENDED PURPOSE

All Vallox air handling units have been designed to provide continuous ventilation appropriate for the intended use without any health risks or risks of damage to the building structures.

## DISPOSAL OF THE AIR HANDLING UNIT

Do not dispose of electrical appliances with domestic waste. Follow the local laws and regulations on safe and ecological disposal.

Make sure that

- the components are separated and sorted according to the material type.



### NOTE

Visit [www.vallox.com](http://www.vallox.com) for more information



### DANGER

Electrical connections must be fully isolated from the main power source until the final assembly!



### WARNING

Children under the age of eight or persons with a sensory, physical or mental disability or with insufficient understanding and experience of the safe use of the unit shall not be allowed to use the unit unsupervised.

Such persons may use the unit under supervision or by following instructions given by a person responsible for their safety.

Keep an eye on children and do not let them play with the unit.

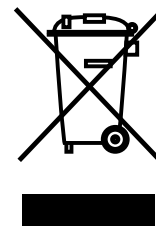

## SAFETY SYMBOLS

**DANGER**

A hazard that will result in death or serious injury, if not avoided.

**WARNING**

A hazard that could result in death or serious injury, if not avoided.

**CAUTION**

A hazard that could result in minor or moderate injury, if not avoided.

**IMPORTANT**

A hazard that could result in damage to property or loss of data, if not avoided.

**NOTE**

Important information about the product.

**TIP**

Additional information about the use of the product and its benefits.

## REGULATIONS – INSTRUCTIONS

If the product has been installed correctly and it is used according to the intended purpose, it is in compliance with all the applicable regulations and requirements for CE markings valid at the time of manufacture. Vallox Pureo SR air handling units are compliant with the Energy-related Products Directive (2018).

## SCOPE OF APPLICATION – INTENDED PURPOSE

Vallox Pureo SR air handling units are energy-efficient, fully automated, quiet and operational ventilation units equipped with heat recovery. Vallox Pureo SR is available in four models with a maximum volume flow demand of 4500 dm<sup>3</sup>/s. The units are equipped with an ePM<sub>1</sub> 60% filter for outdoor air and ePM<sub>10</sub> 60% for extract air.

Vallox Pureo SR units have energy-efficient and quiet fans that save energy. Running with an EC motor, these fans operate at three speeds and they can be controlled with an integrated smart controller based on data provided by air quality sensors. Vallox Pureo SR units are equipped with cross counterflow heat exchangers that recover heat from the extract air before it is blown out through the plates. The process keeps the air flows separate. Depending on the operating conditions, over 80% of the heat in extract air can be recovered before it is blown out.

Supply air is circulated into the priority areas (areas in need of supply air) through the duct system. Air is extracted from secondary areas (such as social premises, bathrooms and showers). The air circulates back to the ventilation unit through the ducts, where heat is recovered before the air is blown out through the extract air duct.

Vallox Pureo SR units have been designed for air handling and the following purposes only:

- Filtration of regular impure air
- Heating and/or cooling of air (with accessories)
- Heat recovery
- Combination of any of the above

The intended purpose includes compliance with the manual and any component-specific instructions provided by the manufacturer as well as inspection and maintenance according to Vallox's instructions.

Standard Vallox Pureo SR units have been designed for installation and use in non-freezing facilities (room temperature +5–45°C). The casing's corrosion class is C4 pursuant to ISO 12944. The unit may be used in the conditions specified below.

Operating conditions:

- Ambient temperature +5–45°C
- Humidity (max.) 90% RH



### IMPORTANT

Freezing could cause physical damage to the unit!







### NOTE

Any use other than the intended purpose of use is prohibited!

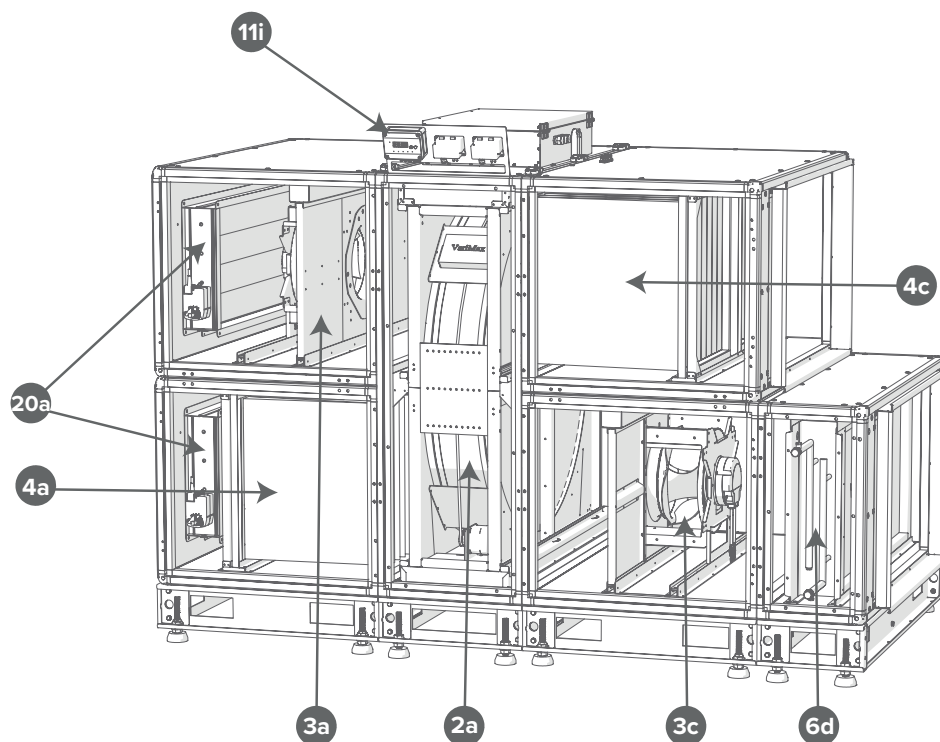
## MAIN PARTS

### Vallox Pureo SR 550–3000





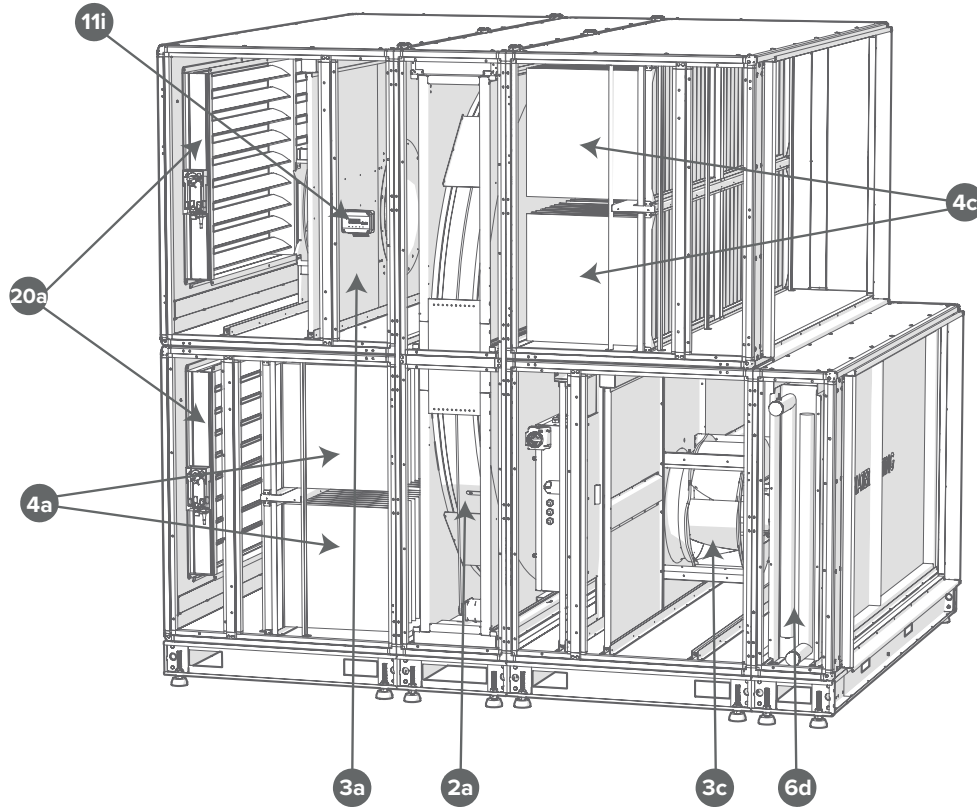

	Rotary heat exchanger	.....	2a		Extract air filter	.....	4c
	Extract air fan	.....	3a		Post-heater (liquid)	.....	6d
	Supply air fan	.....	3c		Pressure transmitter	.....	11i
	Supply air filter	.....	4a		Outdoor air dampers	.....	20a

## MAIN PARTS

### Vallox Pureo SR 4500



- |   |                       |       |    |   |                      |       |     |
|---|-----------------------|-------|----|---|----------------------|-------|-----|
|  | Rotary heat exchanger | ..... | 2a |  | Extract air filter   | ..... | 4c  |
|  | Extract air fan       | ..... | 3a |  | Post-heater (liquid) | ..... | 6d  |
|  | Supply air fan        | ..... | 3c |  | Pressure transmitter | ..... | 11i |
|  | Supply air filter     | ..... | 4a |  | Outdoor air dampers  | ..... | 20a |

## DELIVERY CONTENTS

The delivery includes one of the following units:

- Vallox Pureo SR 550
- Vallox Pureo SR 1000
- Vallox Pureo SR 1500
- Vallox Pureo SR 2000
- Vallox Pureo SR 3000
- Vallox Pureo SR 4500

The delivery also includes:



### NOTE

Inspect the delivery contents upon receipt and make sure everything is in order. If you detect any damage, file a complaint with the transport company immediately. If no complaint is filed within a reasonable time, any future claims for compensation may be invalid.

### SCOPE OF DELIVERY

	M6x20 screw DPT mounting	M8x30 screw Module assembly	M10x25 screw Base frame connection	DPT mounting sheet metal	Condensate drain pipe (set)	Main switch	Door handle	Panel handle
Vallox Pureo SR 550	2	24	12	1	0	1	16	4
Vallox Pureo SR 1000	2	24	12	1	0	1	16	4
Vallox Pureo SR 1500	2	26	12	1	0	1	16	4
Vallox Pureo SR 2000	2	26	12	1	0	1	16	4
Vallox Pureo SR 3000	2	26	12	1	0	1	16	4
Vallox Pureo SR 4000	2	36	12	0	0	1	16	8

The door handles and holders included in the delivery are inside the unit.

## PACKAGE DIMENSIONS AND WEIGHT

The dimensions and weight of each unit type are given in the table below. Vallox Pureo SR units are delivered in four modules.



### IMPORTANT

Before unloading the unit, make sure that the transport devices and hoists meet the weight capacity requirements.

### PACKAGE DIMENSIONS AND WEIGHTS

	No. of packages	Package 1		Package 2		Package 3		Package 4	
		Dimensions (mm) (w x h x d)	Weight (kg)	Dimensions (mm) (w x h x d)	Weight (kg)	Dimensions (mm) (w x h x d)	Weight (kg)	Dimensions (mm) (w x h x d)	Weight (kg)
Vallox Pureo SR 550	4	1055 x 845 x 1780	190	1055 x 541 x 1930	279	1055 x 845 x 1780	190	1220 x 405 x 1070	110
Vallox Pureo SR 1000	4	1360 x 845 x 1780	207	1360 x 541 x 1930	363	1360 x 845 x 1780	207	1505 x 405 x 1070	130
Vallox Pureo SR 1500	4	1665 x 995 x 2390	349	1665 x 541 x 2540	483	1665 x 995 x 2390	349	1815 x 405 x 1375	178
Vallox Pureo SR 2000	4	1970 x 1140 x 2390	424	1970 x 541 x 2540	585	1970 x 1140 x 2390	424	2120 x 405 x 1375	207
Vallox Pureo SR 3000	4	2275 x 1140 x 2390	482	2275 x 541 x 2540	646	2275 x 1140 x 2390	482	2425 x 405 x 1375	229
Vallox Pureo SR 4500	4	2590 x 1140 x 2935	653	2590 x 551 x 3085	832	2590 x 1140 x 2935	653	2745 x 405 x 1615	299

## STORAGE

When the unit is stored for a long period of time, the following measures must be taken to avoid damage: The unit must be packed in a dry, airtight and dust-proof packaging (a plastic bag with drying agent and moisture detectors). The unit must be stored in a watertight and vibrationless place of constant temperature (ambient environment: min. 0°C/max. +40°C). Evidence of damage due to incorrect transport, storage or setup must be provided and such damage shall not be covered by the warranty.

## TRANSPORT AND MOVING

The unit must be transported with utmost care. We recommend the unit be kept in the original packaging until installation to avoid damage or contamination. The unit shall be transported and moved by qualified and experienced personnel and necessary safety measures shall be taken to prevent the unit from falling over or slipping.

Due to its high centre of gravity, the unit could fall over and cause personal injury or damage to property. When transporting the unit, its movements must be followed closely and potentially dangerous areas must be avoided.

The unit can be moved with a forklift truck, pallet truck or crane. The unit must be kept stable when moving it around.



**DANGER**

A falling unit could cause personal injury and/or damage to property!

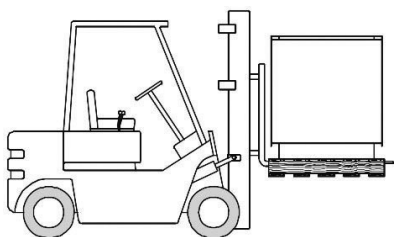

Before moving the unit with a forklift truck, check that the fork is longer than the width of the unit base. Lift the unit slowly.



**DANGER**

A falling unit could cause personal injury and/or damage to property!

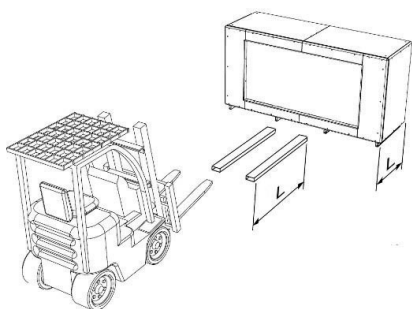

**DANGER**

Incorrect transport or moving practices could cause personal injury and/or damage to property!

Make sure the bearing capacity of the transport devices and hoists is sufficient. Make sure the unit is secured properly before lifting.



**DANGER**

Danger due to lifting!

The hoists, machines or cables could be defective or damaged. Never stand directly below a lifted load.

If the unit is moved by lifting with a crane, the unit must be secured by the holes in the unit base intended for this purpose.

1. Slip the bars of the transport rack through the holes in the unit base.
2. Secure the transport rack in place with screws.
3. Slip a chain or rope around the ends of the bars.
4. Use spacers to prevent the chains or ropes from damaging the unit.

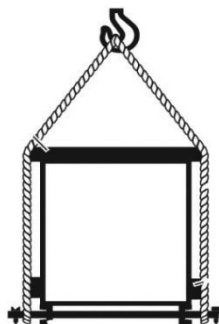
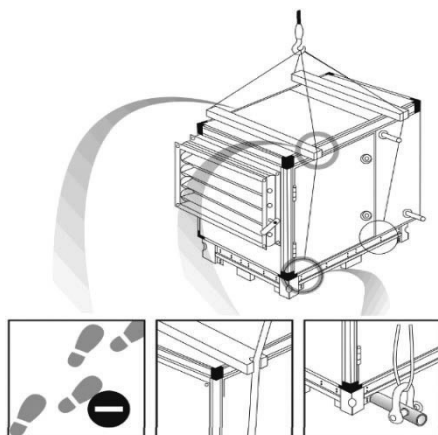

**DANGER**  
Danger due to lifting!  
The hoists, machines or cables could be defective or damaged. Never stand directly below a lifted load.

## DISASSEMBLY AND REASSEMBLY

Disassembly and reassembly are not considered to be normal maintenance measures. The unit shall be disassembled and reassembled by qualified professionals only. Make sure the unit is dead and disconnected from power before disassembly or reassembly. Earth and short-circuit the unit. Protect any adjacent live components.



**WARNING**  
Risk of personal injury or damage to property! An electric shock could result in death or serious injury.

Take the following steps when installing heating and cooling coils:

- Close all hydraulic stop valves.
- Insulate the connections and make sure no oil or refrigerant is leaking from the unit.
- The diameter of the heating and cooling pipes is small and water may remain in the coil even after draining. For safety reasons, blow compressed air into the system to remove any water remaining inside.



**IMPORTANT**  
Risk of damage to property in the installation of heating and cooling coils!

## MECHANICAL ASSEMBLY

The unit shall be installed and connected by experienced professionals only. The person carrying out electrical connection work must have an appropriate qualification and sufficient experience of the applicable safety regulations and other generally recognised safety and occupational health regulations. They must also be authorised to carry out work on the unit.

**⚠ DANGER**  
Mortal danger caused by an electric shock!

The Vallox Pureo SR unit must be installed in an upright position. The system's noise level depends on the level of pressure. This should be considered when choosing the installation location.

The ducts used must be as short as possible, and connecting the unit to the duct system should be effortless. Sharp angles worsen pressure losses and make flow induced noise louder. The maintenance side (handedness) of the unit can be switched.

Make sure that the unit is standing on an even surface before installation.

### Assembly area

Make sure to leave enough room around the unit for carrying out maintenance.

- A Minimum distance from walls
- B Unit width
- C Minimum distance for opening the service door
- D Unit height

ASSEMBLY DIMENSIONS					
	Dimensions (mm)				
	A*	B	C	D	E
Vallox Pureo SR 550	707	1015	1015	1767	430
Vallox Pureo SR 1000	719	1320	1320	1797	430
Vallox Pureo SR 1500	952	1625	1625	2379	430
Vallox Pureo SR 2000	952	1930	1930	2378	430
Vallox Pureo SR 3000	952	2234	2234	2377	430
Vallox Pureo SR 4500	1276	2540	2540	3189	0

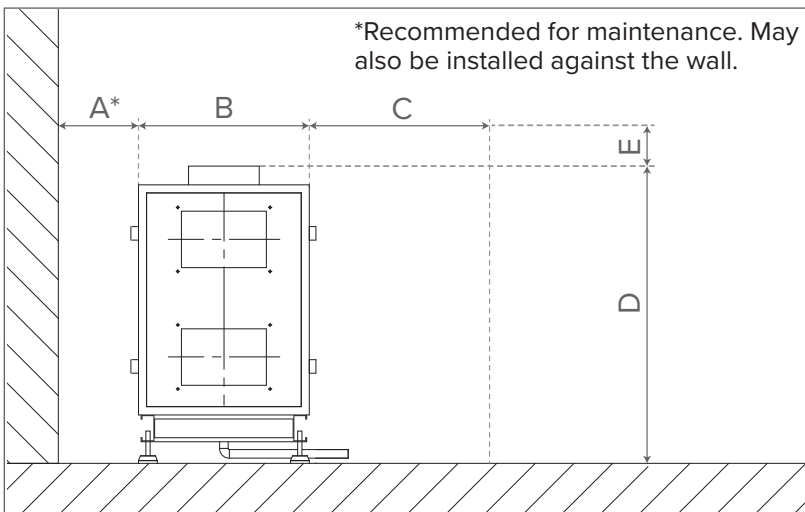

#### IMPORTANT

The ventilation ducts must not get twisted.

The connections must be strong and secure.

The flange connections must be leak-proof and strong.

If necessary, vibrodamping supports may be placed between the unit base and the floor.



#### NOTE

It may be easier to install the accessories before moving the unit to the final location and completing the installation, since there is more room around the unit.

## STABILISATION

Vallox Pureo SR units have adjustable feet. Make sure that the unit is standing on an even floor before installation. The unit is stabilised by adjusting the height of the feet. The maximum permitted height "H" is 125 mm.

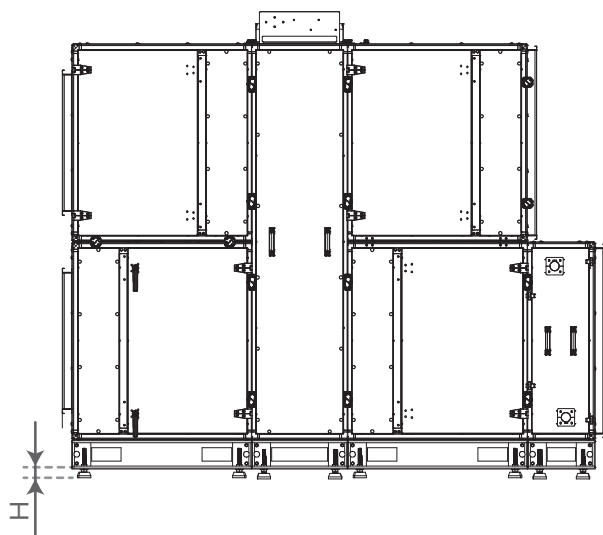

## INSTALLATION OF DOOR HANDLES

The door handles have been packed separately to avoid damage during transport. The door handles are installed once the unit has been installed and stabilised.

Place the handles on the desired maintenance side and secure in place with screws.



### IMPORTANT

Do not open the doors before the unit is standing on solid ground and it has been stabilised.

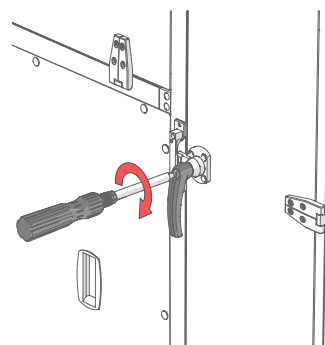
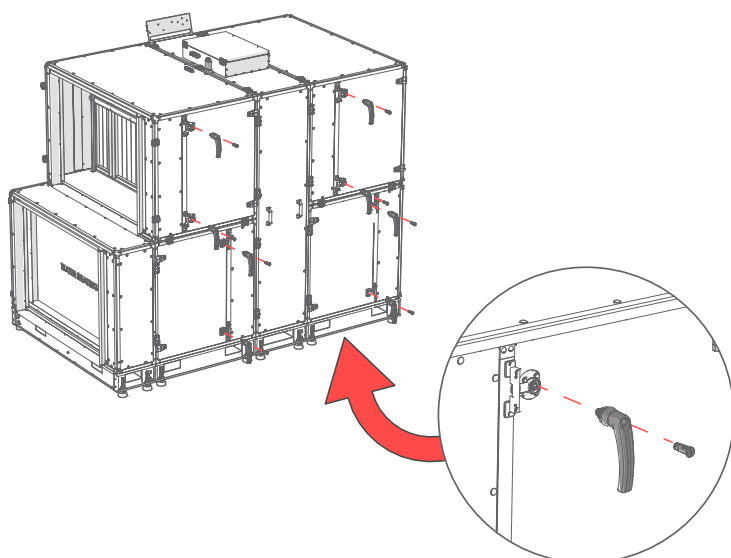

## CHANGING THE HANDEDNESS OF MAINTENANCE

### Switching the maintenance side of the rotary heat exchanger

The standard maintenance side of Vallox Pureo SR units is the right side. To change the maintenance side to the left side, move the stepping motor and the rotary heat exchanger controller (Varimax) to the left side.

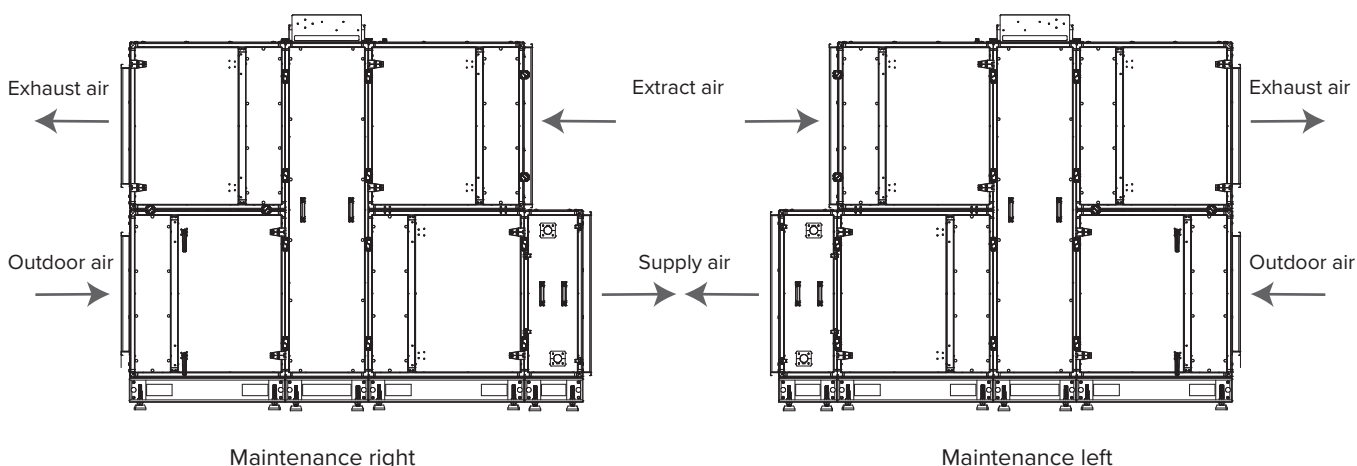

### Switching the maintenance side of the post-heating radiator

Open the maintenance hatch of the fan and disconnect the anti-freezing sensor's connector, remove the hatch on the backside of the post-heating module and release the retainers of the cover on the outlet side of the post-heating radiator. Pull the post-heating radiator and its hatch out of the module and push them back in from the other side of the module. Move the anti-freezing sensor to the fan-side through hole. Rewire the sensor wiring from the supply air fan towards the anti-freezing sensor and reconnect the connector. Attach the backside maintenance hatch and close the retainers of the hatch on the outlet side of the post-heating radiator.

### Changing the handedness of the outdoor air dampers

Open the maintenance hatches of the outdoor air and exhaust air modules on both sides. Disconnect the connectors of the damper actuators and move the module wires to the other side. Remove the dampers from the module whole and turn them around so that the actuators are situated on the new maintenance side. Connect the connectors and close the maintenance hatches.

## ASSEMBLY OF UNIT PARTS

Vallox Pureo SR units consist of four modules, delivered separately.



**DANGER**  
Mortal danger caused by an electric shock!  
An electric shock could result in death or serious injury. Make sure the unit is dead and disconnected from power. Earth and short-circuit the unit. Protect any adjacent live components.

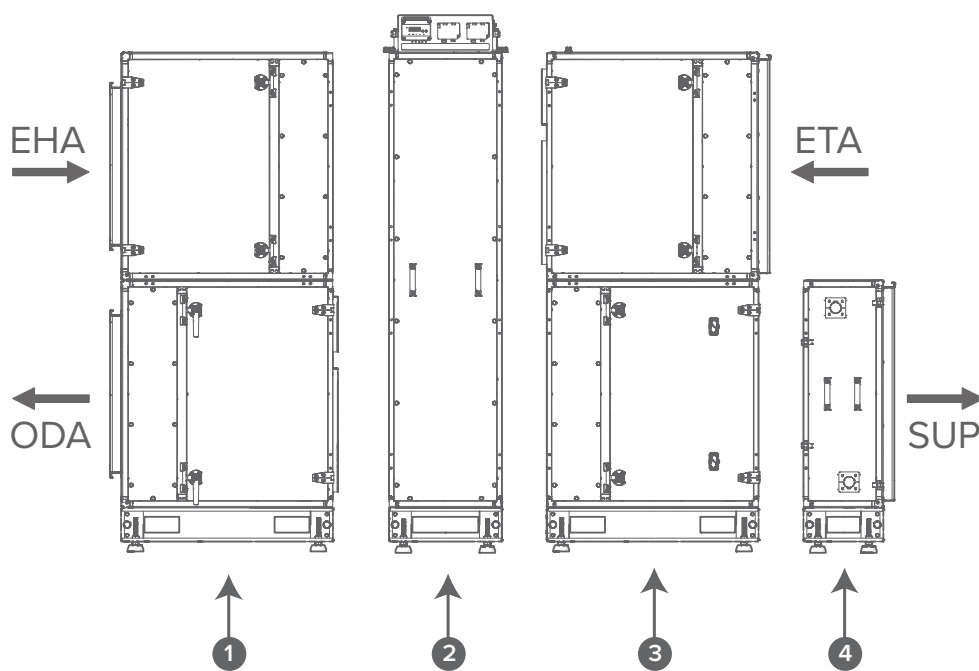

Before assembling the modules together at the final place of installation, place them as close to each other as possible. Use the base of each module to pull them together.

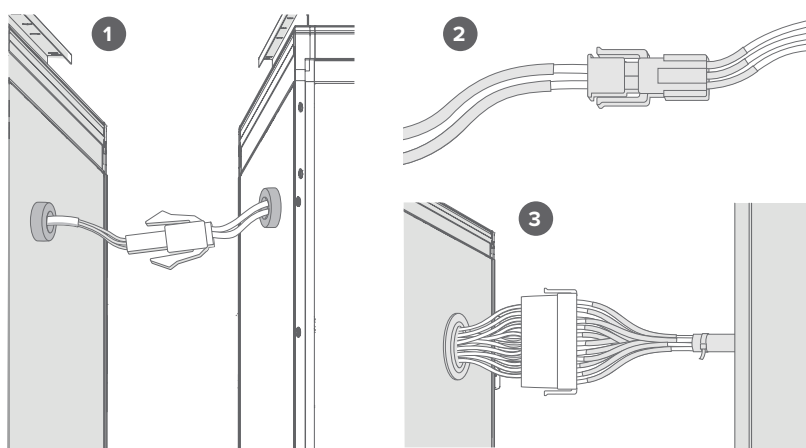

Make sure all the electrical connections have been done carefully.

Make sure the pressure hoses have been connected correctly according to their markings.

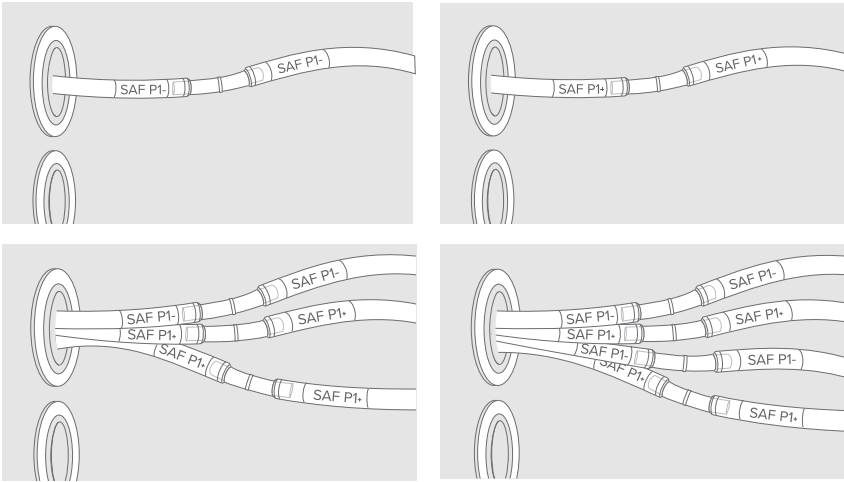

Before assembling the unit, place all the modules as close to each other as possible. Use the base of each module to pull them together. Pull the modules close to each other and tighten with screws.

1. Move the modules as close to each other as possible.
2. Push them from the base only.
3. Press the modules together and tighten with screws.
4. To finish, make sure all the modules have been securely connected.

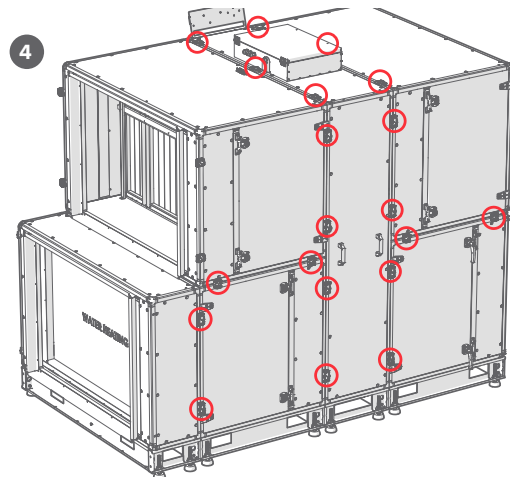
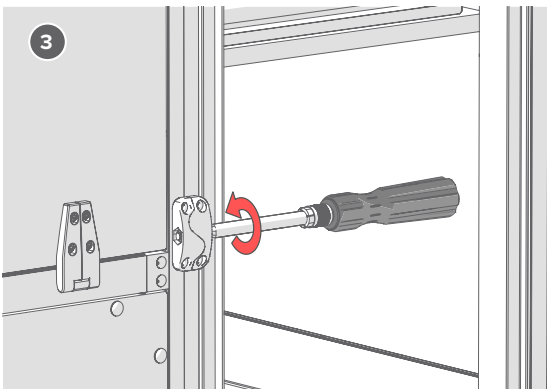
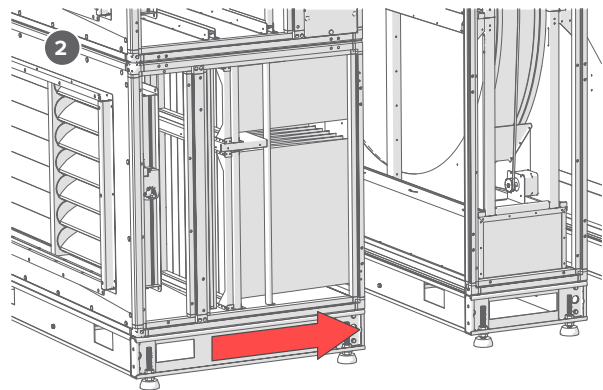
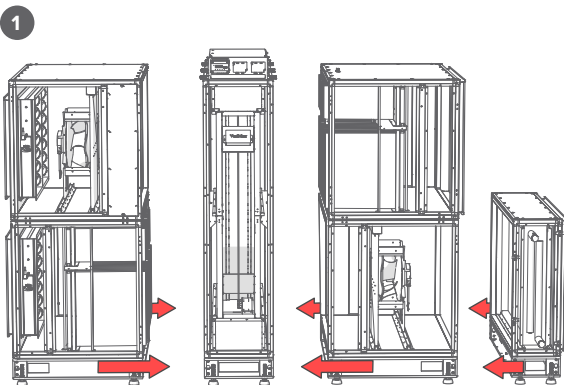

## Flange connections and adapters

The dimensions of the unit's flange connections have been listed in the table below.

### DIMENSIONS FOR THE UNIT FLANGE CONNECTIONS

	Outdoor air/exhaust air duct (mm)					Supply air/extract air duct (mm)				
	R	S	T	U	n	R	S	T	U	n
Vallox Pureo SR 550	672	423,4	650	401,4	4	681	667,6	661	646,4	4
Vallox Pureo SR 1000	977	424	955	402	4	986	667,6	966	646,4	4
Vallox Pureo SR 1500	1282	722,5	1260	700,5	4	1291	972,6	1271	951,4	4
Vallox Pureo SR 2000	1587	722,5	1565	700,5	4	1596	972,6	1576	951,4	4
Vallox Pureo SR 3000	1891	722,4	1869	700,4	4	1901	972,6	1881	951,4	4
Vallox Pureo SR 4500	2126	921	2104	899	4	2206	1277,6	2186	1256,4	4

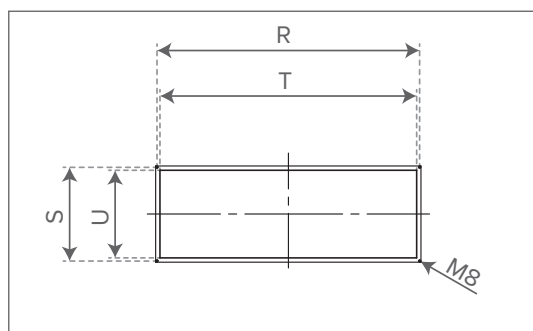

**NOTE**

The ducts must be secured tightly to the connection valves.

Connect the ducts, connector and flexible duct to the unit corners with M8x16 screws.

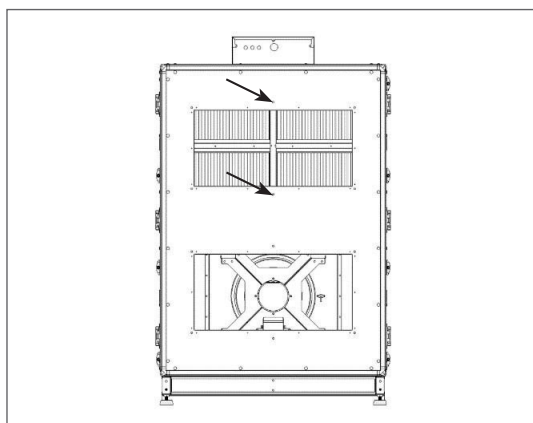

**NOTE**

After tightening the screws, the accessory must be secured with supports.

## DUCT SYSTEM

Follow the local regulations on fireproofing and air ducts.

## ELECTRICAL CONNECTIONS



### DANGER

Mortal danger caused by an electric shock!

The unit must be fully isolated from the mains before carrying out maintenance and installation work and before opening the connection box! Electrical connections shall be made by a qualified electrician only according to the wiring diagram used. Electrical connections must be fully isolated from the main power source until the final assembly!

The unit has a main switch and an insulator, which has been protected against unauthorised use with a D-lock. Applicable standards, safety regulations, and technical requirements set for the connection by the local electricity company shall be complied with. The unit is connected to the mains through the connection box or the main switch. The unit controller (not included in the standard delivery) is connected to the unit with a cable provided with the controller. The Vallox Pureo control panel is connected to the unit with a cable. The control cable should not be longer than 10 metres. The unit shall be classified as “professional equipment” according to the applicable standard. A low-voltage connection is allowed if discussed in advance with the electrical contractor.



### NOTE!

The following circuit breakers are recommended:

CIRCUIT BREAKERS			
	Phase	Type	Circuit breakers (A)
Vallox Pureo SR 550	~1	C	10
Vallox Pureo SR 1000	~1	C	10
Vallox Pureo SR 1500	~3	C	10
Vallox Pureo SR 2000	~3	C	10
Vallox Pureo SR 3000	~3	C	16
Vallox Pureo SR 4500	~3	C	16

For more information about the connection of optional components to the mains, please see the instructions for installation and use of said component.

## MAINS CONNECTION

1. Open the connection box cover.
2. Check the diameter of the cable used for the mains connection.
3. Loosen the marked grommet and slip the cables through it.

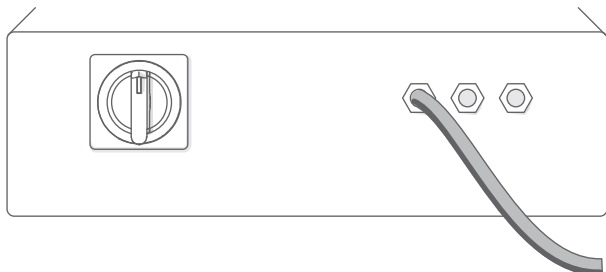

4. Connect the cables to the correct connectors.

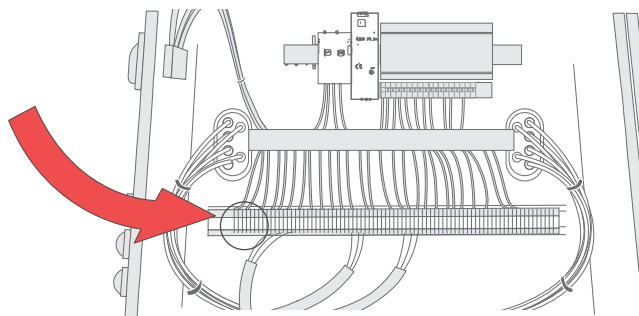

## CONTROLLER CONNECTION



### DANGER

Mortal danger caused by an electric shock!

An electric shock could result in death or serious injury. Make sure the unit is dead and disconnected from power. Earth and short-circuit the unit. Protect any adjacent live components.



### WARNING

Danger due to an electric shock, moving parts (fan) and hot surfaces!

1. Open the connection box cover.



2. Loosen the marked grommet and slip the cables through it.
3. Connect the control cable to the correct connectors on the connection box (see. Electrical connections).
4. Connect the other end of the HMI cable to the display(see. Electrical connections).

## DIMENSIONS AND DUCT OUTLETS

### Vallox Pureo SR 550

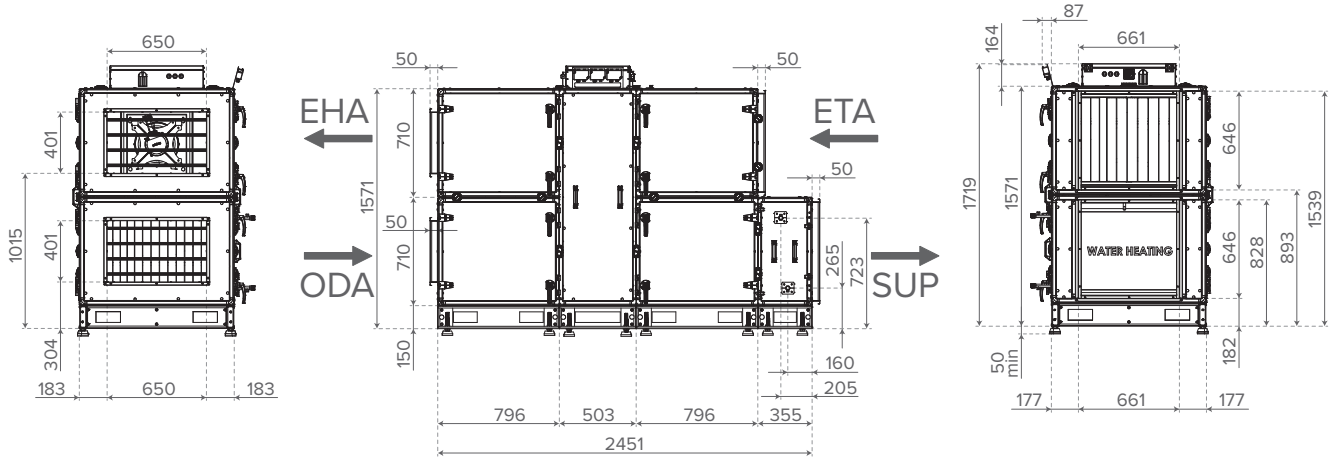

EHA - Exhaust air  
ODA - Outdoor air  
ETA - Extract air  
SUP - Supply air

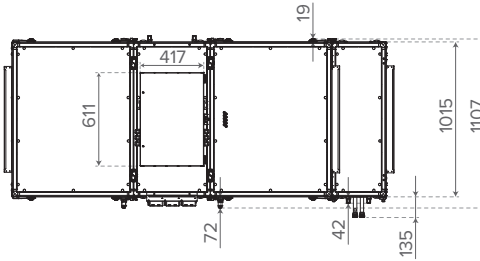

### Vallox Pureo SR 1000

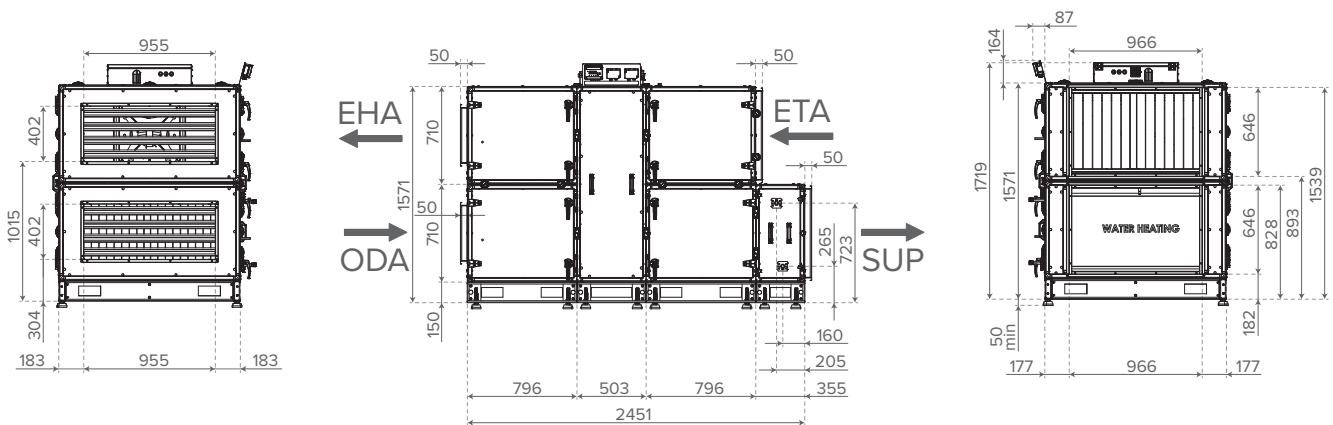

EHA - Exhaust air  
ODA - Outdoor air  
ETA - Extract air  
SUP - Supply air

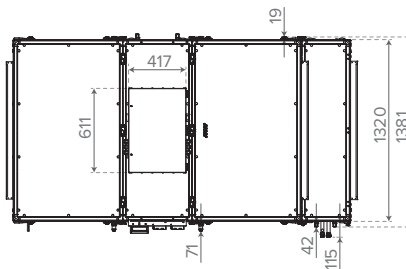

### Vallox Pureo SR 1500

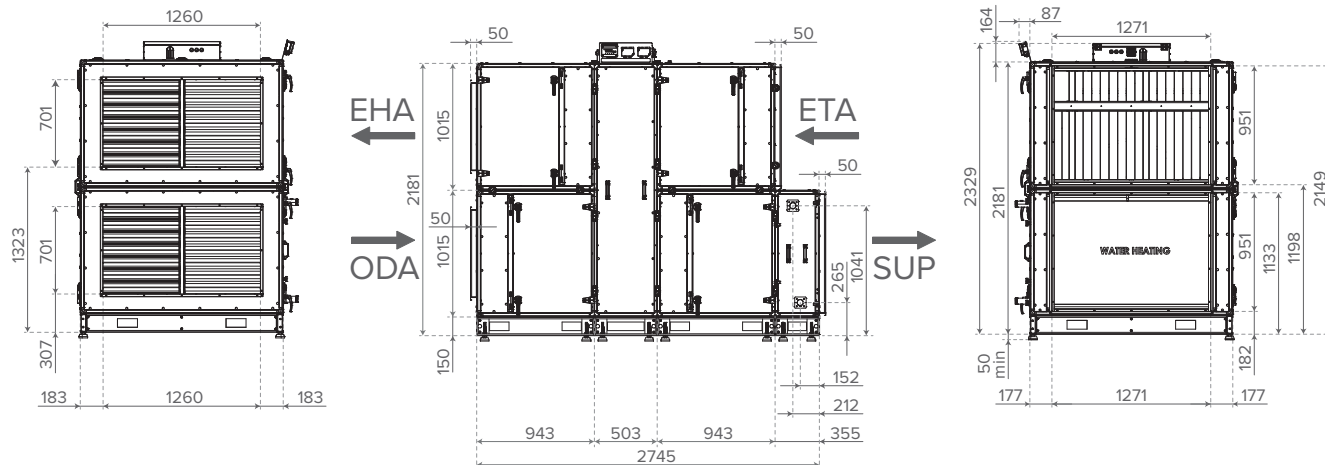

EHA - Exhaust air  
ODA - Outdoor air  
ETA - Extract air  
SUP - Supply air

### Vallox Pureo SR 2000

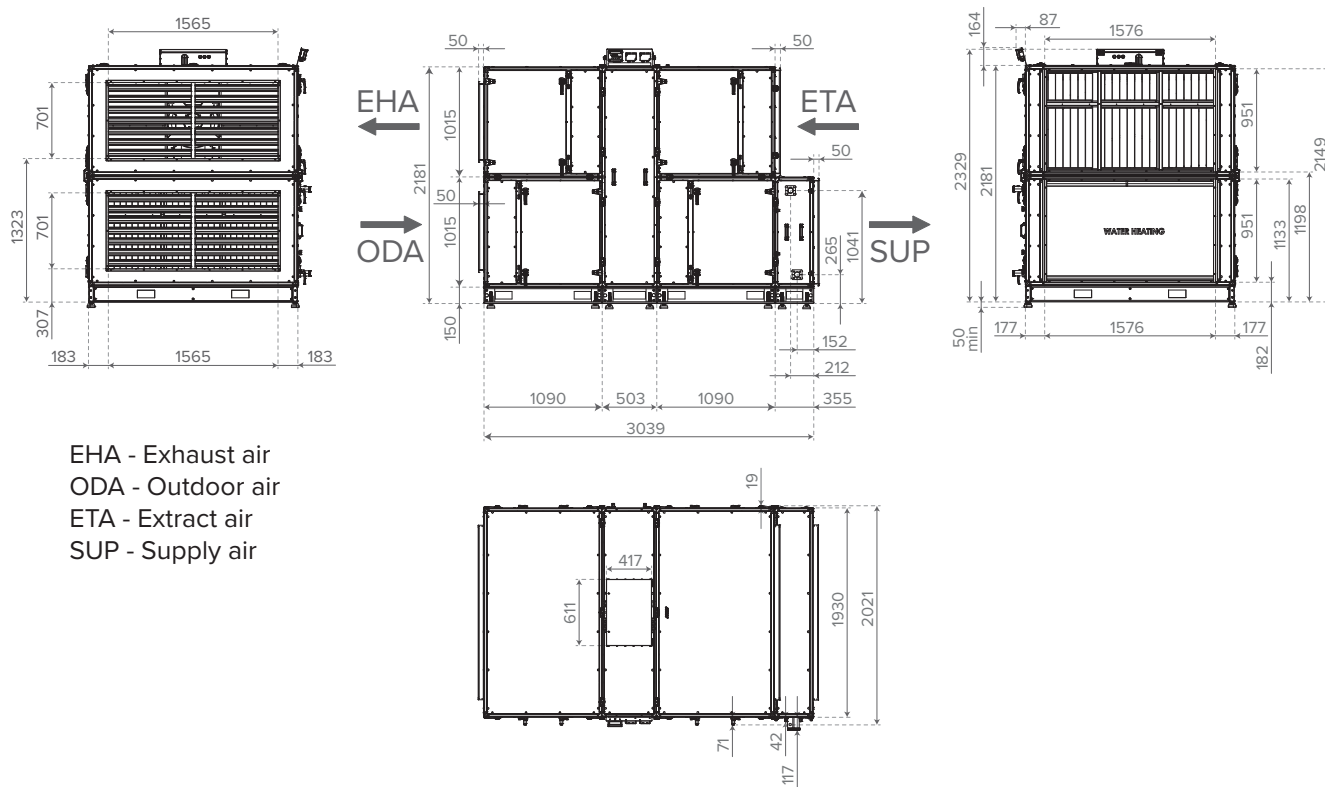

EHA - Exhaust air  
ODA - Outdoor air  
ETA - Extract air  
SUP - Supply air

### Vallox Pureo SR 3000

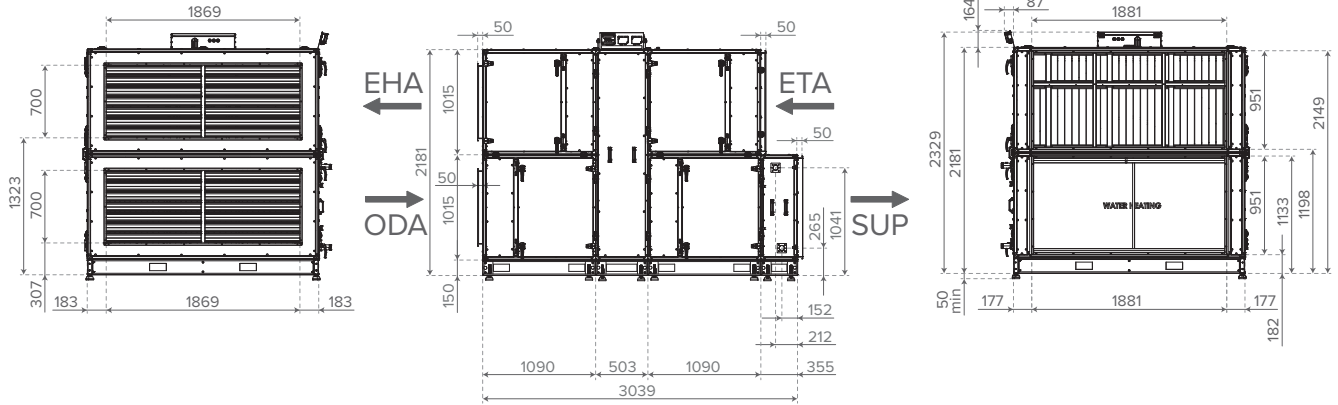

EHA - Exhaust air  
ODA - Outdoor air  
ETA - Extract air  
SUP - Supply air

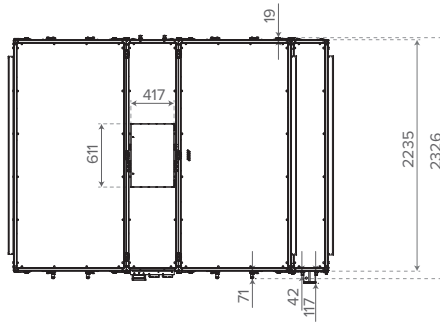

### Vallox Pureo SR 4500

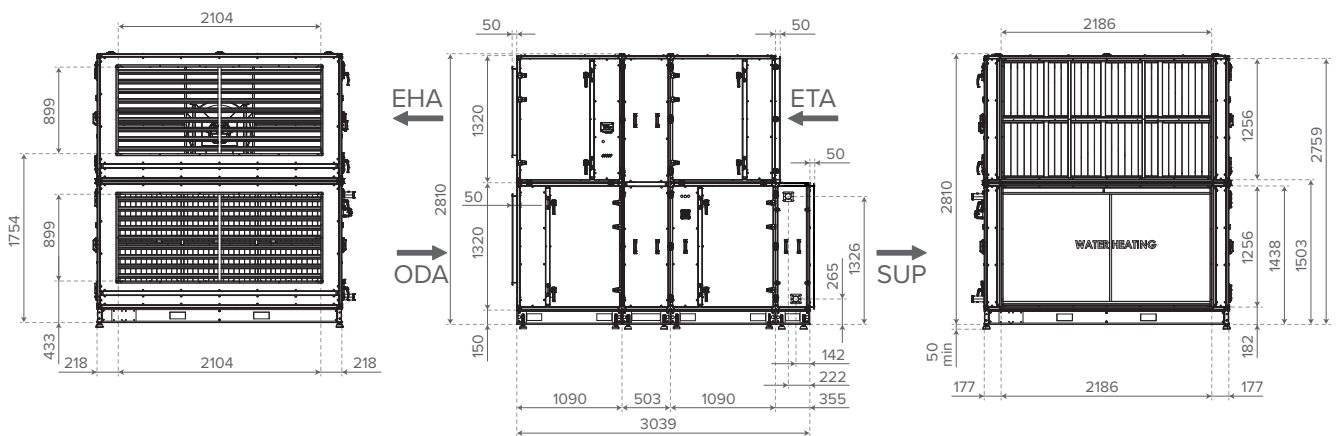

EHA - Exhaust air  
ODA - Outdoor air  
ETA - Extract air  
SUP - Supply air

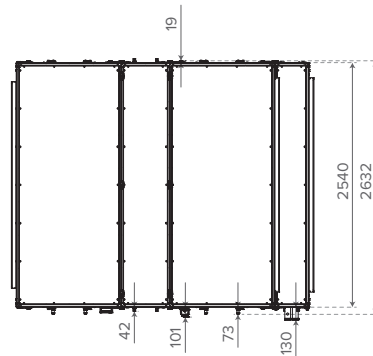

## SERVICE AND MAINTENANCE

The unit shall be cleaned and maintained by professionals only.

The unit must be fully isolated from the mains before carrying out maintenance and installation work and before opening the service door.

 **DANGER**  
Mortal danger caused by an electric shock!



**CAUTION**  
After cutting off the power, wait for five (5) minutes before starting maintenance work!

## MAINTENANCE PLAN

The unit must be fully isolated from the mains before carrying out maintenance and installation work and before opening the connection box! Electrical connections shall be made by a qualified electrician only according to the wiring diagram used. Electrical connections must be fully isolated from the main power source until the final assembly!

 **DANGER**  
Danger due to an electric shock, moving parts (fan) and hot surfaces!

The unit must be inspected regularly according to the maintenance plan:

MAINTENANCE PLAN					
Part	Measure (if necessary)	3 months	6 months	12 months	24 months
<b>1. Outdoor air and exhaust air duct outlets</b>					
Check for contamination, damage and corrosion	Clean and repair				X
<b>2. Filters</b>					
Check for harmful contamination and damage (leaks) and odours	Replace defective filters	X			
<b>3. Air ducts</b>					
Check the accessible areas for damage	Repair			X	
Check 2–3 typical locations for contamination, corrosion and condensation on the duct surface	Check the other duct areas for a need of cleaning (not only visible areas!)			X	
<b>4. Fan</b>					
Check for contamination, damage and corrosion	Clean and repair		X		
<b>5. Heat exchanger</b>					
Check the rotary heat exchanger visually for contamination, damage and corrosion	Clean and repair		X		
Heating coil: Check for contamination, damage and corrosion and make sure the seals are tight	Clean and repair, replace	X			
Cooling coil (optional): Check the coil, droplet separator and condensate tray for contamination, damage and corrosion and make sure the seals are tight	Clean and repair	X			
<b>6. Casing</b>					
Check for harmful contamination and damage (leaks) and odours	Clean and repair	X			

## SERVICE AND MAINTENANCE OF THE ROTARY HEAT EXCHANGER

The unit must be fully isolated from the mains before carrying out maintenance and installation work and before opening the connection box! Danger due to an electric shock, moving parts (fan) and hot surfaces!



### WARNING

The heat exchanger is extremely heavy! Maintenance work shall always be carried out by at least two people!



### DANGER

Mortal danger caused by an electric shock!

## DISASSEMBLY

1. Loosen the screws and remove the maintenance panels.
2. Remove the connectors of the sectional defrosting damper and bypass actuator.
3. Pull at the latches and release the heat exchanger.
4. Remove the rotary heat exchanger carefully and put it down safely.

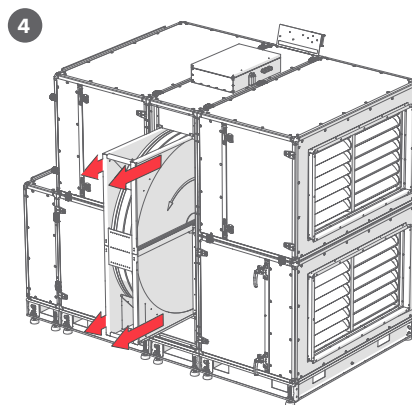
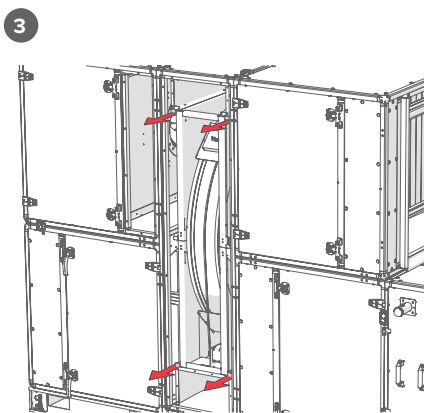
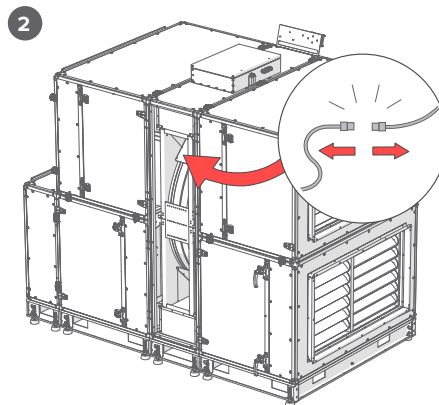
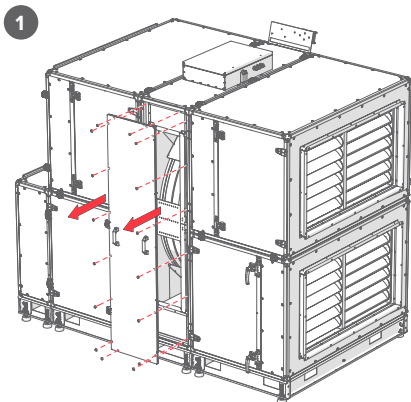

A forklift truck may be used to remove the heat exchanger. Make sure to leave enough room for the forklift truck to maintain the heat exchanger.

## CLEANING

The rotary heat exchanger must be inspected regularly for any dirt and dust. The heat exchanger must also be inspected for damage every six months. Check the following:

- Drive belt tightness
  - Condition of the bearings (bearing sounds)
  - Condition of the casing
1. Place the nozzle of the cleaning device approximately 300 mm from the heat exchanger.

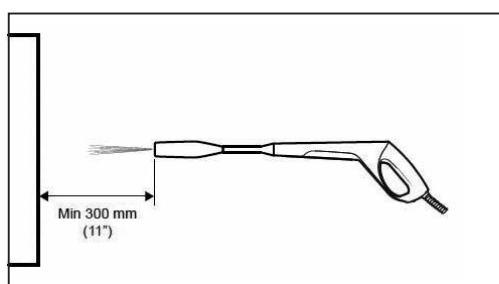

2. Set the nozzle to a simple jet.
3. Wash the heat exchanger at a 30° angle, at a distance of 300 mm.
4. Wash the entire rotor. Turn the rotor to wash the parts behind the

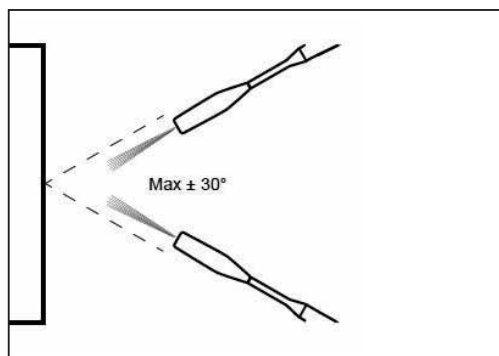

frame.

5. Allow the heat exchanger to air dry.
6. Spray the heat exchanger with a cleaning agent.
7. Repeat steps 1–5 and wash off the cleaning agent.



### IMPORTANT

Allow the heat exchanger to dry before installation!

## REPLACING THE FILTERS

The unit must be fully isolated from the mains before maintenance and cleaning.

The filters must be inspected for dirt, damage and odours every three months. If the filters are damp or mouldy, replace them immediately.

Vallox Pureo SR units are equipped with an ePM<sub>1</sub> 60% filter for outdoor air and ePM<sub>10</sub> 60% for extract air. If other types of filters are used, the settings of the unit controller must be changed.

 **DANGER**  
Mortal danger caused by an electric shock!

The technical specifications of a standard filter are listed in the table below:

1. Open the doors by releasing the retainer and turning the handles anticlockwise.
2. Open the filter's retainer rail by pulling at it and remove the filter.

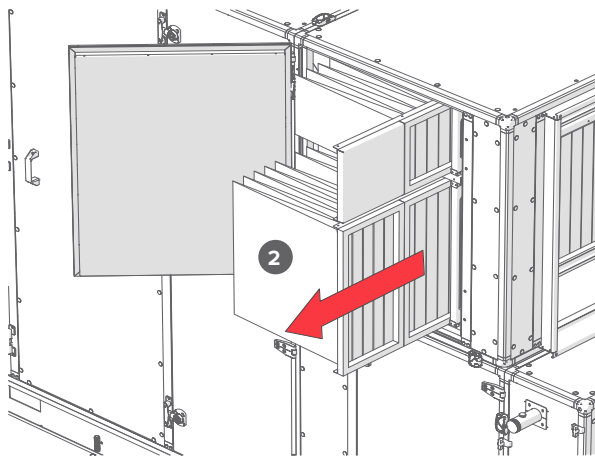
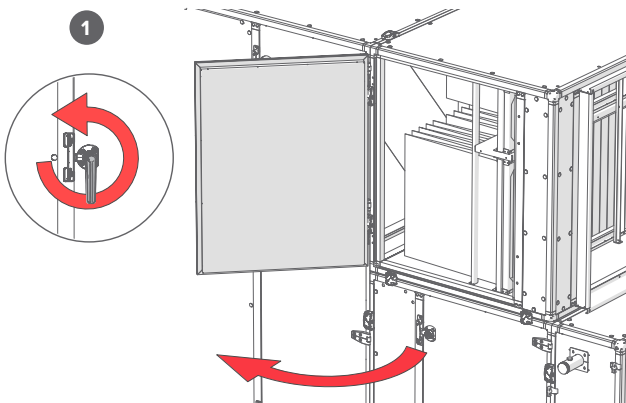

**IMPORTANT**  
Check the air flow direction when installing the filter.



**NOTE**  
Replacement filters are also available online at [filters.vallox.com](http://filters.vallox.com)

### TECHNICAL DATA FOR STANDARD FILTERS

	Filters	Nominal air volume flow (dm <sup>3</sup> /s)	Number of filters	Filter class	Dimensions (mm) (l x h x w)	Recommended final pressure differential (Pa)
Vallox Pureo SR 550	Extract air	550	1	ePM <sub>10</sub> 60 %	592 x 592 x 535	111
Vallox Pureo SR 550	Extract air	550	1	ePM <sub>10</sub> 60 %	592 x 287 x 535	111
Vallox Pureo SR 550	Outdoor air	550	1	ePM <sub>1</sub> 60 %	592 x 592 x 535	111
Vallox Pureo SR 550	Outdoor air	550	1	ePM <sub>1</sub> 60 %	592 x 287 x 535	111
Vallox Pureo SR 1000	Extract air	1000	2	ePM <sub>10</sub> 60 %	592 x 592 x 535	151
Vallox Pureo SR 1000	Outdoor air	1000	2	ePM <sub>1</sub> 60 %	592 x 592 x 535	151
Vallox Pureo SR 1500	Extract air	1500	2	ePM <sub>10</sub> 60 %	592 x 592 x 535	132
Vallox Pureo SR 1500	Extract air	1500	2	ePM <sub>10</sub> 60 %	592 x 287 x 535	132
Vallox Pureo SR 1500	Extract air	1500	1	ePM <sub>10</sub> 60 %	287 x 592 x 535	132
Vallox Pureo SR 1500	Outdoor air	1500	2	ePM <sub>1</sub> 60 %	592 x 592 x 535	132
Vallox Pureo SR 1500	Outdoor air	1500	2	ePM <sub>1</sub> 60 %	592 x 287 x 535	132
Vallox Pureo SR 1500	Outdoor air	1500	1	ePM <sub>1</sub> 60 %	287 x 592 x 535	132
Vallox Pureo SR 2000	Extract air	2000	3	ePM <sub>10</sub> 60 %	592 x 592 x 535	138
Vallox Pureo SR 2000	Extract air	2000	3	ePM <sub>10</sub> 60 %	592 x 287 x 535	138
Vallox Pureo SR 2000	Outdoor air	2000	3	ePM <sub>1</sub> 60 %	592 x 592 x 535	138
Vallox Pureo SR 2000	Outdoor air	2000	3	ePM <sub>1</sub> 60 %	592 x 287 x 535	138
Vallox Pureo SR 3000	Extract air	3000	3	ePM <sub>10</sub> 60 %	592 x 592 x 535	164
Vallox Pureo SR 3000	Extract air	3000	4	ePM <sub>10</sub> 60 %	592 x 287 x 535	164
Vallox Pureo SR 3000	Extract air	3000	1	ePM <sub>10</sub> 60 %	287 x 592 x 535	164
Vallox Pureo SR 3000	Outdoor air	3000	3	ePM <sub>1</sub> 60 %	592 x 592 x 535	164
Vallox Pureo SR 3000	Outdoor air	3000	4	ePM <sub>1</sub> 60 %	592 x 287 x 535	164
Vallox Pureo SR 3000	Outdoor air	3000	1	ePM <sub>1</sub> 60 %	287 x 592 x 535	164
Vallox Pureo SR 4500	Extract air	4500	8	ePM <sub>10</sub> 60 %	592 x 592 x 535	159
Vallox Pureo SR 4500	Outdoor air	4500	8	ePM <sub>1</sub> 60 %	592 x 592 x 535	159

## SERVICE AND MAINTENANCE OF FANS

The unit must be fully isolated from the mains before maintenance and cleaning. Risk of injury due to an electric shock, moving parts (fan) and hot surfaces!

 **WARNING**  
Mortal danger caused by an electric shock!

Be careful when carrying out maintenance work – the fans are very heavy. The fans must be inspected for dirt, damage and corrosion every six months or more frequently, depending on the dirtiness of the blades:

- Regular inspections and cleaning carried out whenever necessary help prevent imbalance caused by dirt.
- Clean the fan casing.
- Make sure the unit does not vibrate or move.
- Wipe the fan clean with a damp cloth. Do not use corrosive agents that could damage the paint. It is prohibited to use a pressure washer and a water jet to clean the fan.
- If water enters the motor: dry the fan carefully before restarting the unit.

 **WARNING**  
Risk of injury due to the weight of the unit!

### K FACTORS

Vallox Pureo SR 550	98
Vallox Pureo SR 1000	145
Vallox Pureo SR 1500	190
Vallox Pureo SR 2000	250
Vallox Pureo SR 3000	375
Vallox Pureo SR 4500	545

1. Open the doors by releasing the retainer and turning the handles anticlockwise.
2. Disconnect the fan connector.
3. Disconnect the pressure hoses from the fan.
4. Remove the fan carefully.

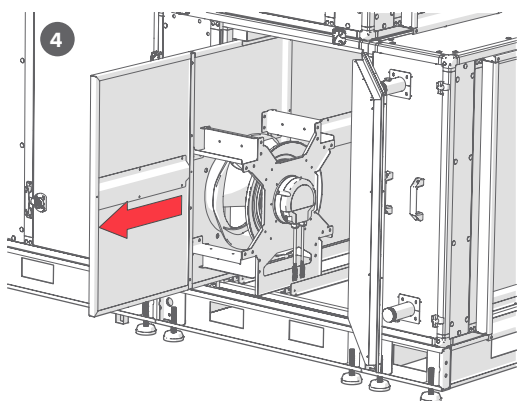
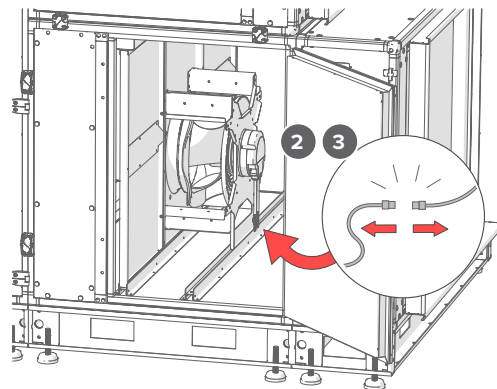
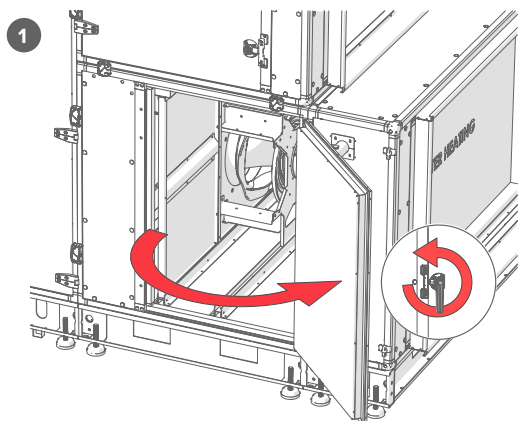

**NOTE**

When installing the fan, pay attention to the electrical connections and the correct connection of the pressure hoses.

## CLEANING THE UNIT

The unit must be fully isolated from the mains before maintenance and cleaning. Risk of injury due to an electric shock, moving parts (fan) and hot surfaces!

- The unit must be inspected for dirt, damage and corrosion once a year.
- Wipe the unit clean with a damp cloth.



**DANGER**

Mortal danger caused by an electric shock!

## PERFORMANCE AND TECHNICAL SPECIFICATIONS

Rating details and technical specifications are available in the selection software. Available online at [valloxselect.com](http://valloxselect.com).

The mechanical connections must be made correctly to achieve the best possible performance results. The unit's thermal efficiency, noise level and electrical performance could vary depending on the operating conditions. The operating conditions could impact the on-site values, which could differ from the values specified in the selection software.

## EXPLODED VIEW AND PARTS LISTS

### Vallox Pureo SR

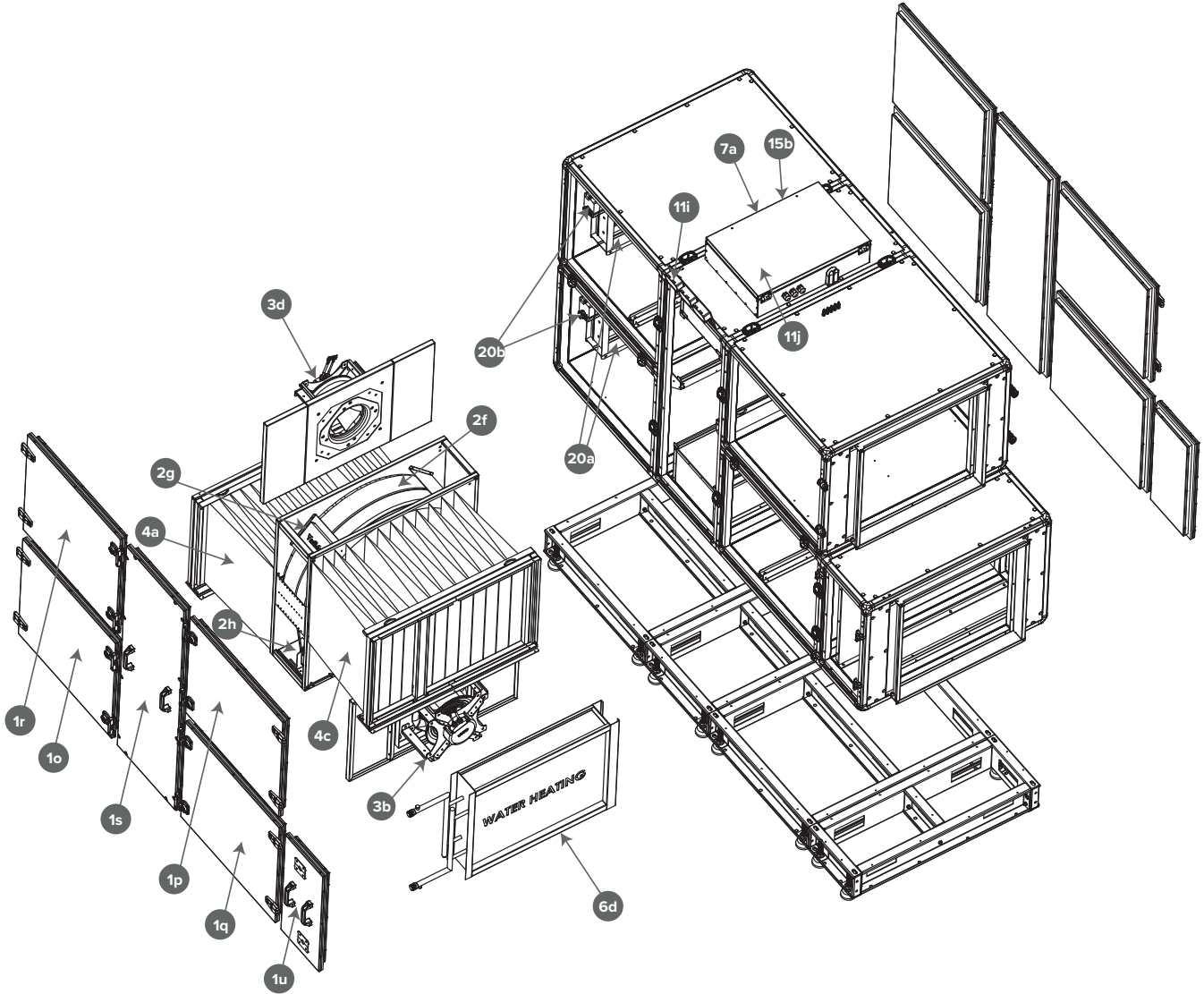

NO	PART	NO	PART	NO	PART
1o	Maintenance hatch of the supply air filter	2g	Rotary heat exchanger controller (Varimax)	7a	Main switch
1p	Maintenance hatch of the extract air filter	2h	Stepping motor	8b	Base frame
1q	Maintenance hatch of the supply air fan	3b	Supply air fan	11i	Pressure transmitter
1r	Maintenance hatch of the extract air fan	3d	Extract air fan	11j	Controller
1s	Maintenance hatch of the rotary heat exchanger	4a	Supply air filter	15b	Electrical box
1u	Maintenance hatch of the post-heating radiator	4c	Extract air filter	20a	Outdoor air dampers
2f	Rotary heat exchanger	6d	Post-heater (liquid)	20b	Actuator for outdoor air dampers

## DEVICE CONNECTIONS

Terminal block	Pureo 5ch differential pressure transmitter		Device
1	24V -	Blue	┌
2	24V +	Red	~
A	A	White	A
B	B	Yellow	B



Ouman 5-CDPT

Terminal block	Pureo controller		Device
1	24V -	Blue	1
2	24V +	Yellow	2
A	A	Red	A
B	B	White	B

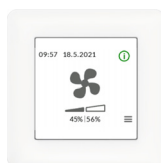

Ouman RU-23

Terminal block	Cooling coil actuator	Device
7	24V -	1
8	24V +	2
9	0-10V	3
10		



Belimo NRYD24-SR-HW

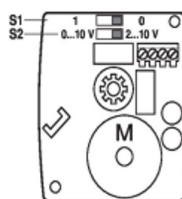

S1		
0*		Y = 0%
1		Y = 0%
S2		
2 ... 10 V*		
0 ... 10 V		

### Wiring diagrams

AC/DC 24V, voltage-controlled

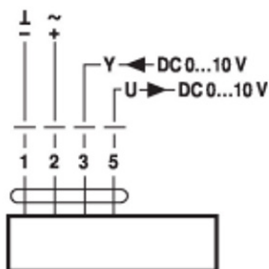

### Cable colours:

- 1 = black
- 2 = red
- 3 = white
- 5 = orange

Terminal block	Heating coil actuator	Device
7	24V -	5
8	24V +	6
11	0-10V	4
12		



ESBE Series ARA639

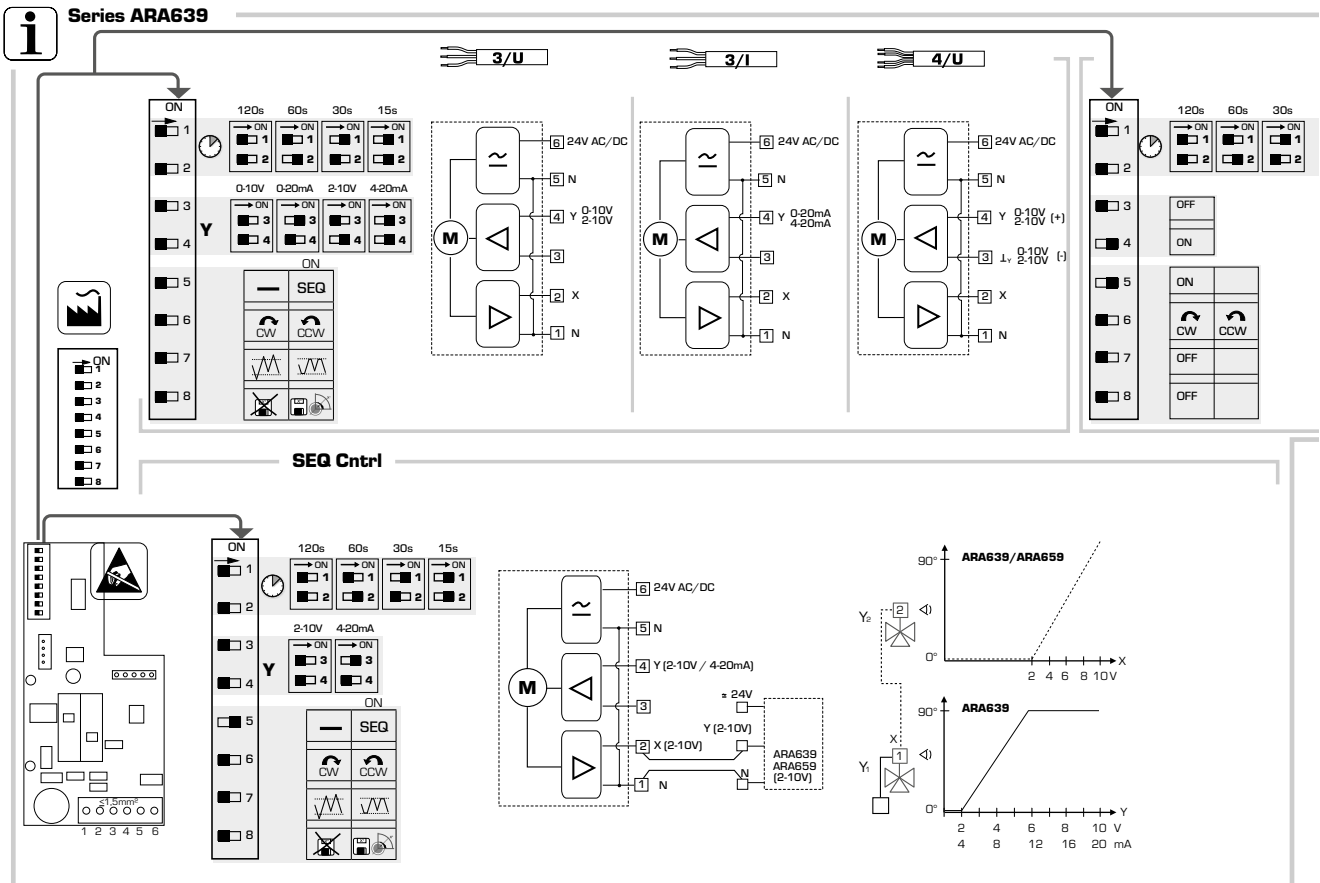

On-site cabling SU.

Terminal block	CO2 transmitter	Device
7	24V -	G0
8	24V +	G0
13	0-10V	Y1



Produl HDK-N

**CAUTION:** Device wiring and commissioning can only be carried out by qualified professionals. Always make the wirings while the power is switched off.

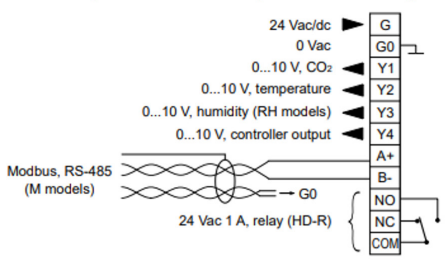

Terminal block	VOC transmitter	Device
7	24V -	G0
8	24V +	G0
15	0-10V	Y1



Produl ILK-N

**CAUTION:** Device wiring and commissioning can only be carried out by qualified professionals. Always make the wirings while the power is switched off.

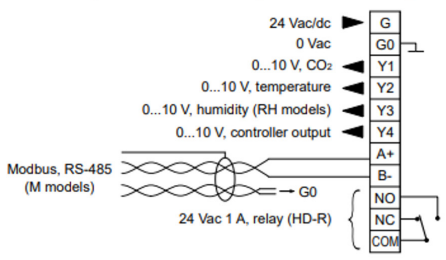

Terminal block	Outdoor air temperature in the duct	Device
19	NTC	1
20	GND	2



Ouman TMD

Terminal block	Supply air temperature in the duct	Device
21	NTC	1
22	GND	2



Ouman TMD

Terminal block	Pressure transmitter for the supply air duct	Device
7	24V -	GND
8	24V +	24VDC
23	0-10V	0-10V

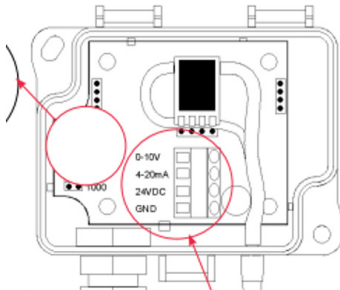

Pressure area selected 0-500 Pa



Ouman DPT-T

Terminal block	Pressure transmitter for the extract air duct	Device
7	24V -	GND
8	24V +	24VDC
25	0-10V	0-10V

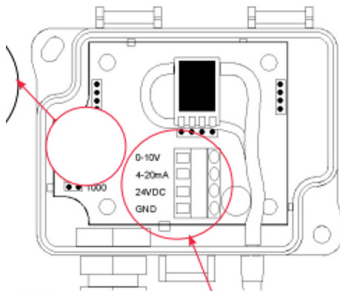

Pressure area selected 0-500 Pa



Ouman DPT-T

Terminal block	Additional timer
27	COM
28	NO

Connection

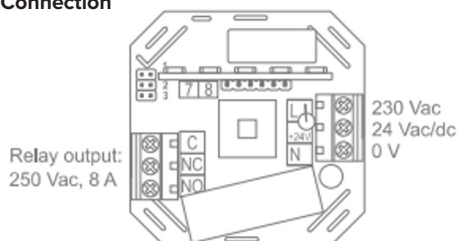

E.g. Proidual LxE

The LAP xE electronic timer is suitable for e.g. controlling boosted ventilation. Press the button to set the time. The indicators show the time set.

Terminal block	Emergency stop
29	COM
30	NC

Short circuit as a factory setting

### EC DECLARATION OF CONFORMITY

**Manufacturer** Vallox Oy  
Myllykyläntie 9-11, FIN-32200 LOIMAA, FINLAND  
Tel. +358 10 7732 200, Fax +358 10 7732 201

**Declares that:**

Description of unit Air handling unit  
Model Vallox Pureo SR 550, Vallox Pureo SR 1000, Vallox Pureo SR 1500, Vallox Pureo SR 2000, SR3000, SR4500 and accessories for each respective size that fall within the scope of these directives.

If the product is installed correctly and used to its intended purpose, it conforms to below standards and directives at its date of manufacture.

**Directives**

1. Machinery Directive 2006/42/EC
2. Low Voltage Directive 2014/35/EU
3. EMC Directive 2014/30/EU
4. Restriction of Hazardous Substances (RoHS) Directive 2011/65/EU
5. Eco-design (Commission regulation (EU) No. 1253/2014) 2009/125/EC

**Standards**

1. SFS-EN JSO 12100:2010 Safety of machinery. General principles for design. Risk assessment and risk reduction
2. EN60204-1 Safety of machinery. Electrical equipment of machines. General requirements
3. EN 61000-6-3 Electromagnetic compatibility (EMC). Generic standards. Emission standard for residential, commercial and light-industrial environments
4. EN13053:2019 Air handling units - Rating and performance for units, components and sections
5. EN1886:2007 Ventilation for buildings - Air handling units - Mechanical performance

**The person who compiles the technical file** Juho Mäki  
Vallox Oy  
Myllykyläntie 9-11, FIN-32200 LOIMAA, FINLAND  
Tel. +358 107 732 296  
Fax +358 10 7732 201  
Email [juho.maki@vallox.com](mailto:juho.maki@vallox.com)

This declaration relates exclusively to the machinery in the state in which it was placed on the market and installed according to Vallox Oy's instructions. This declaration does not include components which are added or changes done subsequently to the unit.

This is the original Declaration of Conformity

Loimaa, 16<sup>th</sup> December 2025



Jukka-Pekka Korja  
Managing Director



# VALLOX

[www.vallox.com](http://www.vallox.com)

Vallox Oy | Myllykyläntie 9-11 | FI-32200 LOIMAA | FINLAND

D12069/13.03.2026