

Model

Vallox Pureo TX 350
Vallox Pureo TX 500
Vallox Pureo TX 900
Vallox Pureo TX 1300
Vallox Pureo TX 1800

Document
D9674

Valid from
01.03.2026

Updated
13.03.2026

VALLOX Pureo TX

Manual



Air handling units

CONTENTS

INTRODUCTION	2	TECHNICAL SPECIFICATIONS	35
Safety	3	Performance and technical specifications	35
Installation	3	Exploded views and parts lists	36
Warranty	3	Vallox Pureo TX 350	36
Intended purpose	3	Vallox Pureo TX 500/900	37
Disposal of the air handling unit	3	Vallox Pureo TX 1300/1800	38
Safety symbols	4	Device connections	39
Regulations – Instructions	4	Declaration of conformity	43
Scope of application – intended purpose	5		
Main parts	6		
Vallox Pureo TX 350	6		
Vallox Pureo TX 500/900	7		
Vallox Pureo TX 1300/1800	8		
Delivery contents	9		
Package dimensions and weight	9		
Storage	9		
Transport and moving	10		
Disassembly and reassembly	11		
INSTALLATION	12		
Mechanical assembly	12		
Assembly area	12		
Stabilisation	13		
Installation of door handles	13		
Changing the handedness of maintenance	14		
Draining of condensate	14		
Assembly of unit parts Vallox Pureo TX 1300/1800	16		
Flange connections and adapters	19		
Duct system	19		
Electrical connections	20		
Mains connections	21		
Main switch installation	22		
Controller connection	22		
Dimensions and duct outlets	23		
Vallox Pureo TX 350	23		
Vallox Pureo TX 500	24		
Vallox Pureo TX 900	25		
Vallox Pureo TX 1300	26		
Vallox Pureo TX 1800	27		
Operating characteristics	27		
MAINTENANCE	28		
Service and maintenance	28		
Maintenance plan	28		
Service and maintenance of the cross counterflow heat exchanger	29		
Disassembly	29		
Cleaning	30		
Filter replacement	31		
Service and maintenance of fans	32		
Cleaning the condensate tray	34		
Cleaning the unit	34		

SAFETY

Safe and appropriate handling of the unit requires an understanding of the applicable basic safety regulations and the intended purpose of the ventilation system. Read this manual before using the air handling unit and keep it safe for later use. If you lose the manual, you can find and download it on our website.

This manual contains all the information needed for the safe use of the system. All persons using and maintaining the ventilation system shall follow the instructions in this manual. They must also comply with any local safety regulations to prevent accidents.

Installation

The installation and setup of the unit shall be carried out by qualified professionals only. Electrical installations and electrical connections shall be done by an electrician in compliance with the local legislation.

WARRANTY

The warranty and the manufacturer's responsibility do not cover damage caused by:

- Inappropriate use of the ventilation system or control unit
- Incorrect or inappropriate installation, setup or use of the unit
- Failure to comply with the instructions for transport, installation, use or maintenance
- Structural or electronic modifications, or changes made to the software

INTENDED PURPOSE

All Vallox air handling units have been designed to provide continuous ventilation appropriate for the intended use without any health risks or risks of damage to the building structures.

DISPOSAL OF THE AIR HANDLING UNIT

Do not dispose of electrical appliances with domestic waste. Follow the local laws and regulations on safe and ecological disposal.

Make sure that

- the components are separated and sorted according to the material type.



NOTE

Visit www.vallox.com for more information



DANGER

Electrical connections must be fully isolated from the main power source until the final assembly!



WARNING

Children under the age of eight or persons with a sensory, physical or mental disability or with insufficient understanding and experience of the safe use of the unit shall not be allowed to use the unit unsupervised.

Such persons may use the unit under supervision or by following instructions given by a person responsible for their safety.

Keep an eye on children and do not let them play with the unit.



SAFETY SYMBOLS

**DANGER**

A hazard that will result in death or serious injury, if not avoided.

**WARNING**

A hazard that could result in death or serious injury, if not avoided.

**CAUTION**

A hazard that could result in minor or moderate injury, if not avoided.

**IMPORTANT**

A hazard that could result in damage to property or loss of data, if not avoided.

**NOTE**

Important information about the product.

**TIP**

Additional information about the use of the product and its benefits.

REGULATIONS – INSTRUCTIONS

If the product has been installed correctly and it is used according to the intended purpose, it is in compliance with all the applicable regulations and requirements for CE markings valid at the time of manufacture. Vallox Pureo TX air handling units are compliant with the Energy-related Products Directive (2018).

SCOPE OF APPLICATION – INTENDED PURPOSE

Vallox Pureo TX air handling units are energy-efficient, fully automated, quiet and operational ventilation units equipped with heat recovery. Vallox Pureo TX is available in four models with a maximum volume flow demand of 1800 dm³/s. The units are equipped with an ePM₁ 60% filter for outdoor air and ePM₁₀ 60% for extract air.

Vallox Pureo TX units have energy-efficient and quiet fans that save energy. Running with an EC motor, these fans operate at three speeds and they can be controlled with an integrated smart controller based on data provided by air quality sensors. Vallox Pureo TX units are equipped with cross counterflow heat exchangers that recover heat from the extract air before it is blown out through the plates. The process keeps the air flows separate. Depending on the operating conditions, over 80% of the heat in extract air can be recovered before it is blown out.

Supply air is circulated into the priority areas (areas in need of supply air) through the duct system. Air is extracted from secondary areas (such as social premises, bathrooms and showers). The air circulates back to the ventilation unit through the ducts, where heat is recovered before the air is blown out through the extract air duct.

Vallox Pureo TX units have been designed for air handling and the following purposes only:

- Filtration of regular impure air
- Heating and/or cooling of air (with accessories)
- Heat recovery
- Combination of any of the above

The intended purpose includes compliance with the manual and any component-specific instructions provided by the manufacturer as well as inspection and maintenance according to Vallox's instructions.

Standard Vallox Pureo TX units have been designed for installation and use in non-freezing facilities (room temperature +5–45°C). Non-freezing draining of condensate must be ensured on site. The casing's corrosion class is C4 pursuant to ISO 12944. The unit may be used in the conditions specified below.

Operating conditions:

- Ambient temperature +5–45°C
- Humidity (max.) 90% RH



IMPORTANT

Freezing could cause physical damage to the unit!











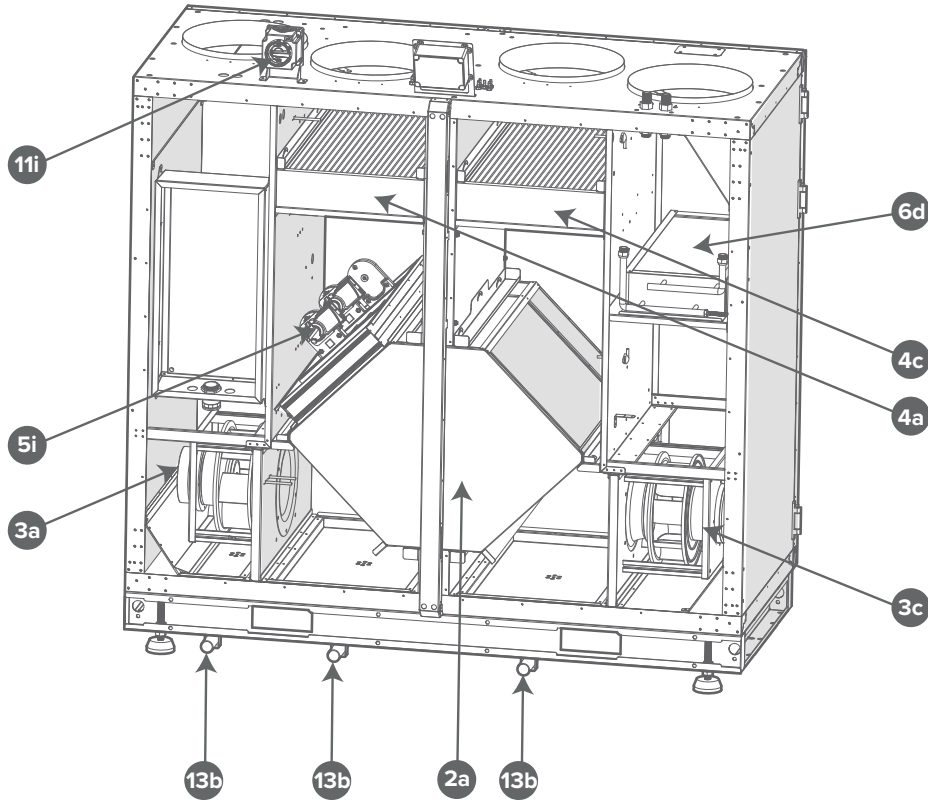

NOTE

Any use other than the intended purpose of use is prohibited!

MAIN PARTS







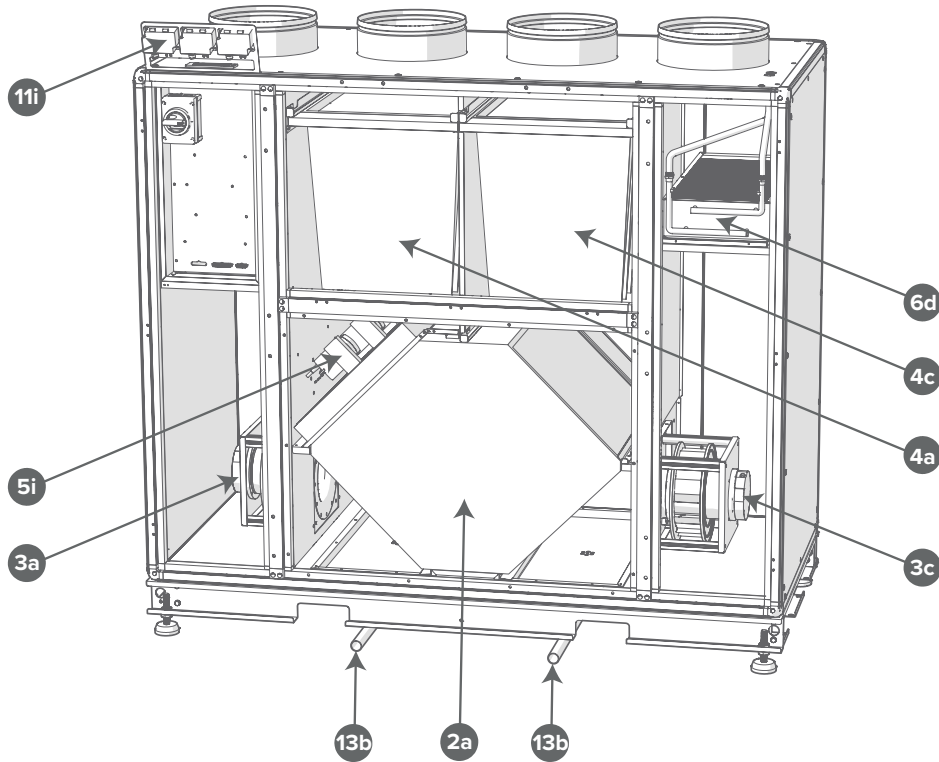

Vallox Pureo TX 350



- | | | | | | |
|---|----------------------------|----|---|-------------------------------------|-----|
|  | Counterflow heat exchanger | 2a |  | Bypass/sectional defrosting dampers | 5i |
|  | Extract air fan | 3a |  | Post-heater (liquid) | 6d |
|  | Supply air fan | 3c |  | Pressure transmitter | 11i |
|  | Supply air filter | 4a |  | Condensation outlet pipe | 13b |
|  | Extract air filter | 4c | | | |







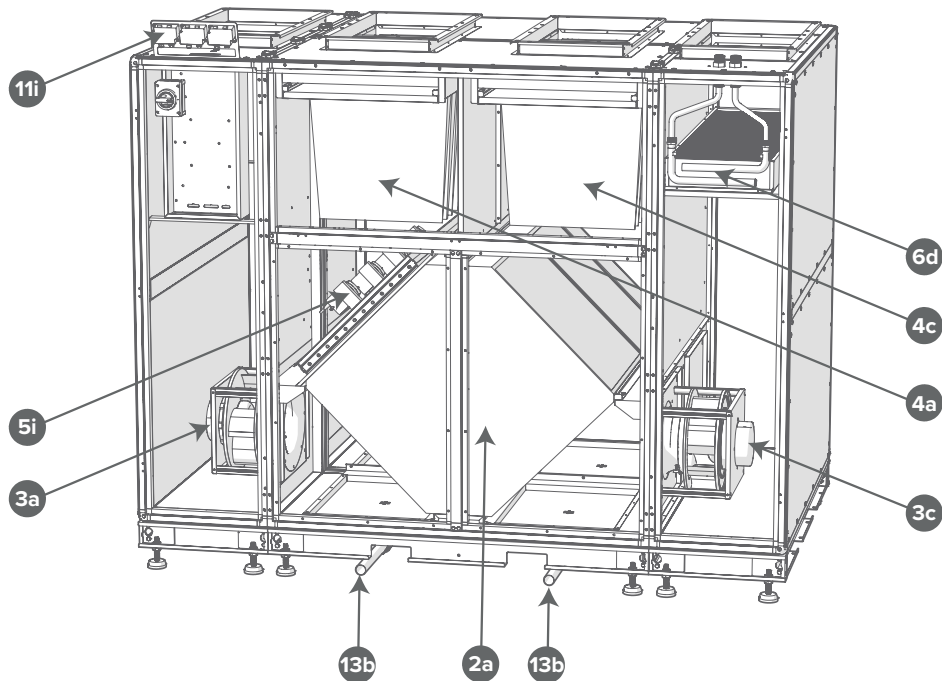

Vallox Pureo TX 500/900



- | | | | | | |
|---|----------------------------|----|---|-------------------------------------|-----|
|  | Counterflow heat exchanger | 2a |  | Bypass/sectional defrosting dampers | 5i |
|  | Extract air fan | 3a |  | Post-heater (liquid) | 6d |
|  | Supply air fan | 3c |  | Pressure transmitter | 11i |
|  | Supply air filter | 4a |  | Condensation outlet pipe | 13b |
|  | Extract air filter | 4c | | | |

Vallox Pureo TX 1300/1800



- | | | | | | |
|---|----------------------------|----|---|-------------------------------------|-----|
|  | Counterflow heat exchanger | 2a |  | Bypass/sectional defrosting dampers | 5i |
|  | Extract air fan | 3a |  | Post-heater (liquid) | 6d |
|  | Supply air fan | 3c |  | Pressure transmitter | 11i |
|  | Supply air filter | 4a |  | Condensation outlet pipe | 13b |
|  | Extract air filter | 4c | | | |

DELIVERY CONTENTS

The delivery includes one of the following units:

- Vallox Pureo TX 350
- Vallox Pureo TX 500
- Vallox Pureo TX 900
- Vallox Pureo TX 1300
- Vallox Pureo TX 1800

The delivery also includes:



NOTE

Inspect the delivery contents upon receipt and make sure everything is in order. If you detect any damage, file a complaint with the transport company immediately. If no complaint is filed within a reasonable time, any future claims for compensation may be invalid.

SCOPE OF DELIVERY

	M6x20 screw DPT mounting	M8x30 screw Module assembly	M10x25 screw Base frame connection	DPT mounting sheet metal	Condensate drain pipe (set)	Main switch with screws	Door handle	U type manometer
Vallox Pureo TX 350	2			1	3	1	1	
Vallox Pureo TX 500	2			1	2	1	16	2
Vallox Pureo TX 900	2			1	2	1	16	2
Vallox Pureo TX 1300	2	24	8	1	2	1	18	2
Vallox Pureo TX 1800	2	24	8	1	2	1	18	2

The condensation outlet pipes, door handles and holders included in the delivery are inside the unit.

PACKAGE DIMENSIONS AND WEIGHT

The dimensions and weight of each unit type are given in the table below. Vallox Pureo TX 1300 and 1800 units are delivered in three modules.



IMPORTANT

Before unloading the unit, make sure that the transport devices and hoists meet the weight capacity requirements.

PACKAGE DIMENSIONS AND WEIGHTS

	No. of packages	Package 1		Package 2		Package 3	
		Dimensions (mm) (w x h x d)	Weight (kg)	Dimensions (mm) (w x h x d)	Weight (kg)	Dimensions (mm) (w x h x d)	Weight (kg)
Vallox Pureo TX 350	1	1600 x 1784 x 756	295				
Vallox Pureo TX 500	1	1993 x 1992 x 960	403				
Vallox Pureo TX 900	1	2370 x 2332 x 980	532				
Vallox Pureo TX 1300	3	654 x 2260 x 1620	221	1612 x 2260 x 1620	488	654 x 2260 x 1620	207
Vallox Pureo TX 1800	3	654 x 2260 x 1880	240	1612 x 2260 x 1880	510	654 x 2260 x 1880	228

STORAGE

When the unit is stored for a long period of time, the following measures must be taken to avoid damage: The unit must be packed in a dry, airtight and dust-proof packaging (a plastic bag with drying agent and moisture detectors). The unit must be stored in a watertight and vibrationless place of constant temperature (ambient environment: min. 0°C/max. +40°C). Evidence of damage due to incorrect transport, storage or setup must be provided and such damage shall not be covered by the warranty.

TRANSPORT AND MOVING

The unit must be transported with utmost care. We recommend the unit be kept in the original packaging until installation to avoid damage or contamination. The unit shall be transported and moved by qualified and experienced personnel and necessary safety measures shall be taken to prevent the unit from falling over or slipping.

Due to its high centre of gravity, the unit could fall over and cause personal injury or damage to property. When transporting the unit, its movements must be followed closely and potentially dangerous areas must be avoided.

The unit can be moved with a forklift truck, pallet truck or crane. The unit must be kept stable when moving it around.

DANGER
A falling unit could cause personal injury and/or damage to property!

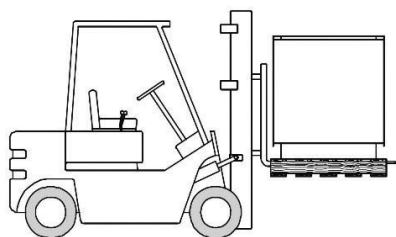

Before moving the unit with a forklift truck, check that the fork is longer than the width of the unit base. Lift the unit slowly.

DANGER
A falling unit could cause personal injury and/or damage to property!

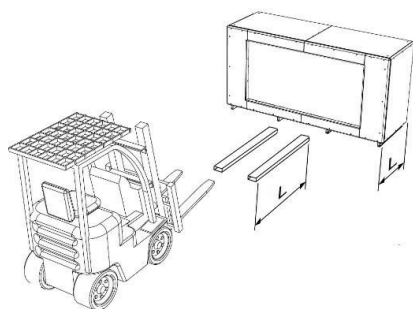

DANGER
Incorrect transport or moving practices could cause personal injury and/or damage to property!

Make sure the bearing capacity of the transport devices and hoists is sufficient. Make sure the unit is secured properly before lifting.



DANGER
Danger due to lifting!
The hoists, machines or cables could be defective or damaged. Never stand directly below a lifted load.

If the unit is moved by lifting with a crane, the unit must be secured by the holes in the unit base intended for this purpose.

1. Slip the bars of the transport rack through the holes in the unit base.
2. Secure the transport rack in place with screws.
3. Slip a chain or rope around the ends of the bars.
4. Use spacers to prevent the chains or ropes from damaging the unit.

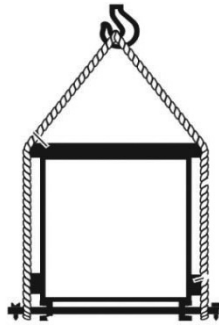
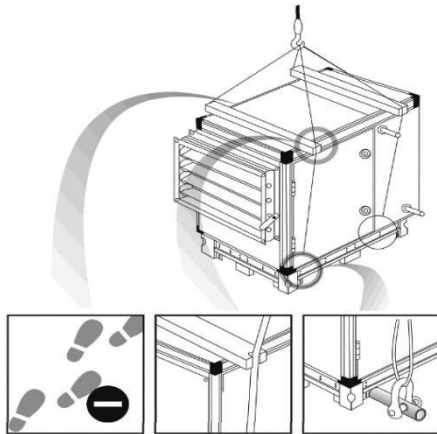

DANGER

Danger due to lifting!

The hoists, machines or cables could be defective or damaged. Never stand directly below a lifted load.

DISASSEMBLY AND REASSEMBLY

Disassembly and reassembly are not considered to be normal maintenance measures. The unit shall be disassembled and reassembled by qualified professionals only. Make sure the unit is dead and disconnected from power before disassembly or reassembly. Earth and short-circuit the unit. Protect any adjacent live components.



WARNING

Risk of personal injury or damage to property! An electric shock could result in death or serious injury.

Take the following steps when installing heating and cooling coils:

- Close all hydraulic stop valves.
- Insulate the connections and make sure no oil or refrigerant is leaking from the unit.
- The diameter of the heating and cooling pipes is small and water may remain in the coil even after draining. For safety reasons, blow compressed air into the system to remove any water remaining inside.



IMPORTANT

Risk of damage to property in the installation of heating and cooling coils!

MECHANICAL ASSEMBLY

The unit shall be installed and connected by experienced professionals only. The person carrying out electrical connection work must have an appropriate qualification and sufficient experience of the applicable safety regulations and other generally recognised safety and occupational health regulations. They must also be authorised to carry out work on the unit.

⚠ DANGER
Mortal danger caused by an electric shock!

The Vallox Pureo TX unit must be installed in an upright position. The system's noise level depends on the level of pressure. This should be considered when choosing the installation location. The room in which the unit is installed must have a wastewater connection. See Draining of condensate (pp. 14–15).

The ducts used must be as short as possible, and connecting the unit to the duct system should be effortless. Sharp angles worsen pressure losses and make flow induced noise louder. The unit may be turned 180° for installation.

Make sure that the unit is standing on an even surface before installation.

Assembly area

Make sure to leave enough room around the unit for carrying out maintenance.

- A Minimum distance from walls
- B Unit width
- C Minimum distance for opening the service door
- D Unit height

ASSEMBLY DIMENSIONS				
	Dimensions (mm)			
	A*	B	C	D
Vallox Pureo TX 350	615	1641	1641	1528
Vallox Pureo TX 500	665	870	870	1662
Vallox Pureo TX 900	795	890	890	1982
Vallox Pureo TX 1300	815	1520	1520	2030
Vallox Pureo TX 1800	815	1720	1720	2030

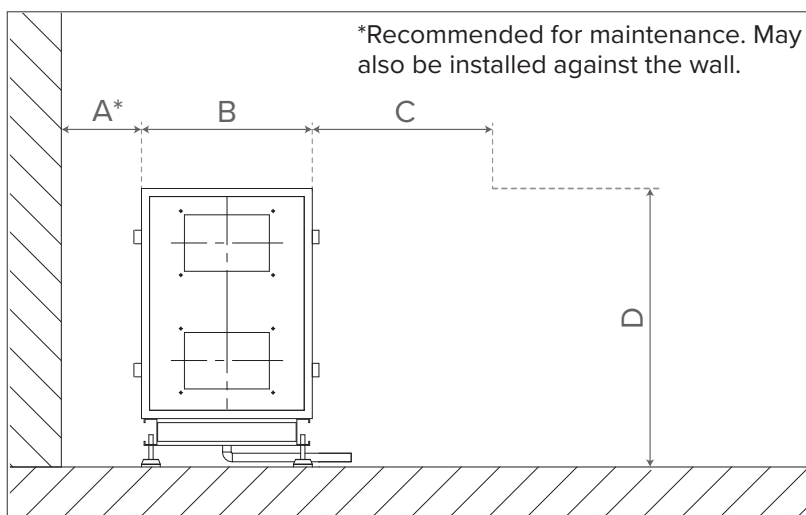

IMPORTANT

The ventilation ducts must not get twisted.

The connections must be strong and secure.

The flange connections must be leak-proof and strong.

If necessary, vibrodamping supports may be placed between the unit base and the floor.



NOTE

It may be easier to install the accessories before moving the unit to the final location and completing the installation, since there is more room around the unit.

STABILISATION

Vallox Pureo TX units have adjustable feet. Make sure that the unit is standing on an even floor before installation. The unit is stabilised by adjusting the height of the feet. The maximum permitted height "H" is 125 mm.

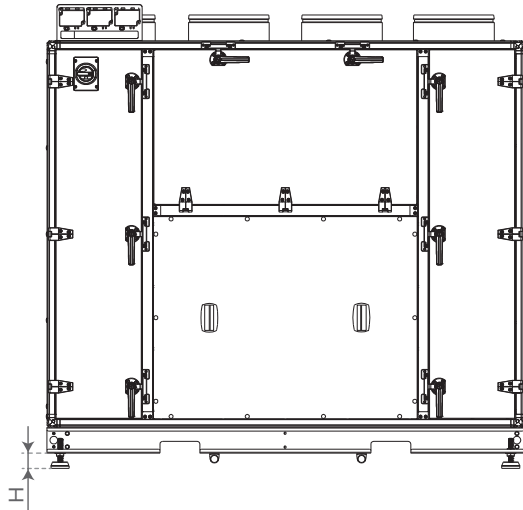

INSTALLATION OF DOOR HANDLES

The door handles have been packed separately to avoid damage during transport. The door handles are installed once the unit has been installed and stabilised.

Place the handles on the desired maintenance side and secure in place with screws.



IMPORTANT

Do not open the doors before the unit is standing on solid ground and it has been stabilised.

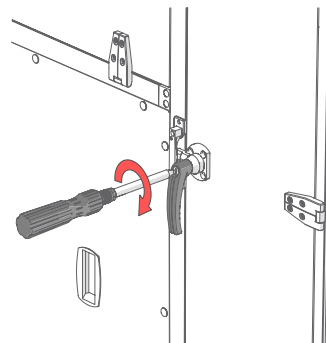
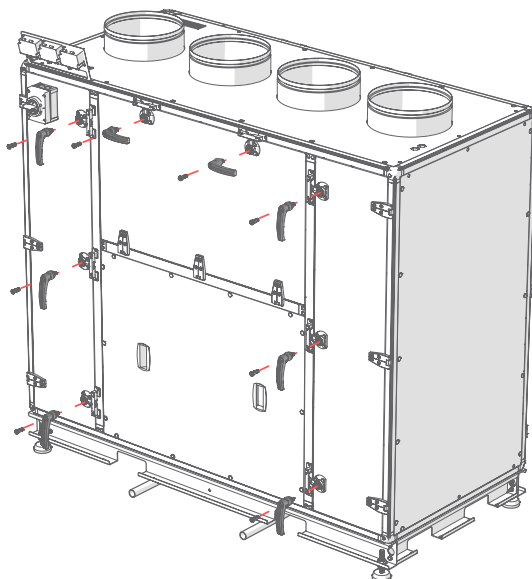

CHANGING THE HANDEDNESS OF MAINTENANCE

Switching the maintenance side of the switchboard

Switch the side before the final installation of the unit.

- Open the maintenance hatch of the extract air fan.
- Take the switchboard's internal cables from their holders.
- Remove the switchboard's fastening bolts.
- Move the switchboard to the other side and fasten it to the holders.
- Fasten the cables to the cable holders and connect the connectors.

DRAINING OF CONDENSATE

Moisture in extract air condenses into water during the heating season. In new buildings with many people present, large amounts of condensate can form in the system. Condensate collected in a stainless steel condensate tray is drained through a drain hole designed for this purpose.



IMPORTANT

The outlet pipe must not run above the siphon. Condensate must be able to drain out effortlessly. If condensate is not properly drained automatically, a condensate pump must be used.

The condensation outlet pipe must be frost-proof!

- Vallox Pureo TX 350 has three condensation outlet pipes: one on the supply air side, one on the exhaust air side and one optional condensation pipe fitting below the extract air fan.
- Vallox Pureo TX 500/900 units have two condensation drain holes – one on the supply side and one on the extract side.
- Vallox Pureo TX 1300/1800 units have two condensation drain holes on the supply side and the extract side (4 pcs in total). Connect the condensation outlet pipes to the maintenance-side drain holes on the supply and extract side.



NOTE

Ball siphon available as an accessory.

Make sure that the condensation outlet pipes have been connected separately.

The condensation outlet pipes must be connected to the wastewater system through a siphon.

Condensate should drain freely into the wastewater system beyond the siphon. Existing draining systems must not be connected directly to the wastewater system.

Make sure that the unused condensate drain holes have been plugged.



NOTE

The optional condensation pipe fitting below the extract air fan (Vallox Pureo TX 350) makes sure that, in situations with high moisture levels, any frost that forms in the exhaust duct does not leak out of the unit.

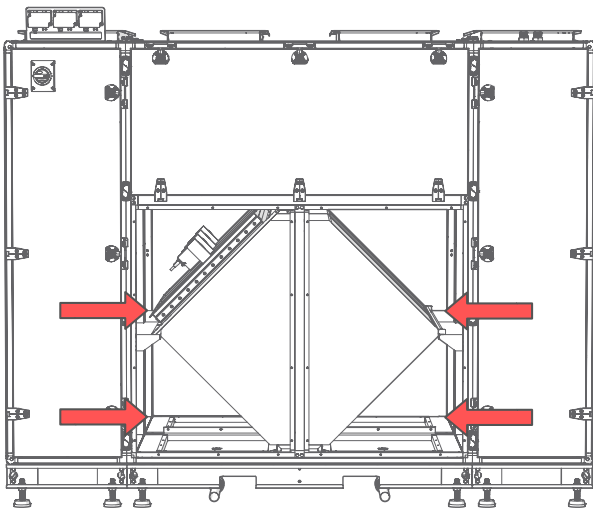

Install an elbow fitting to the condensate tray. Twist the fitting to check that the structure is watertight.

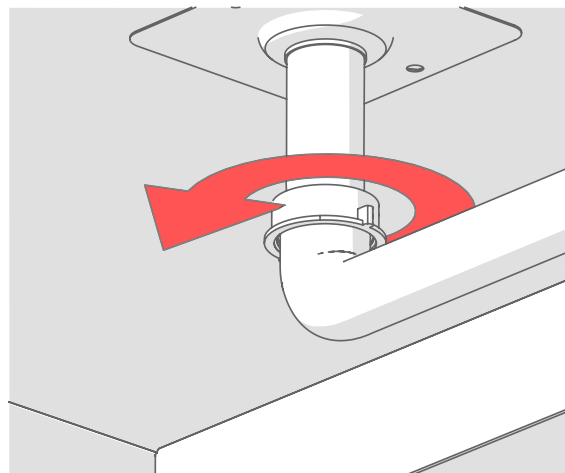
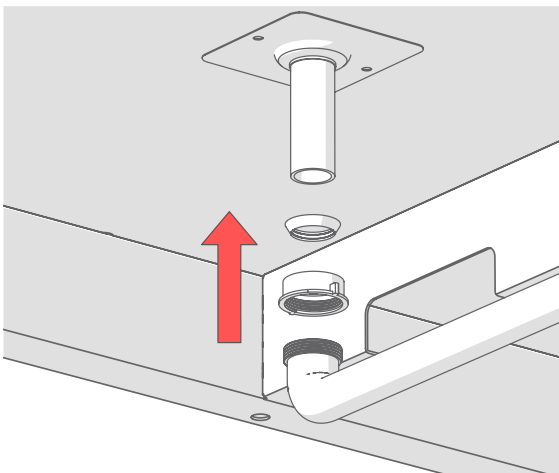

ASSEMBLY OF UNIT PARTS VALLOX PUREO TX 1300/1800

Start the assembly by sealing both heat exchanger module surfaces (Vallox Pureo TX 1300/1800).

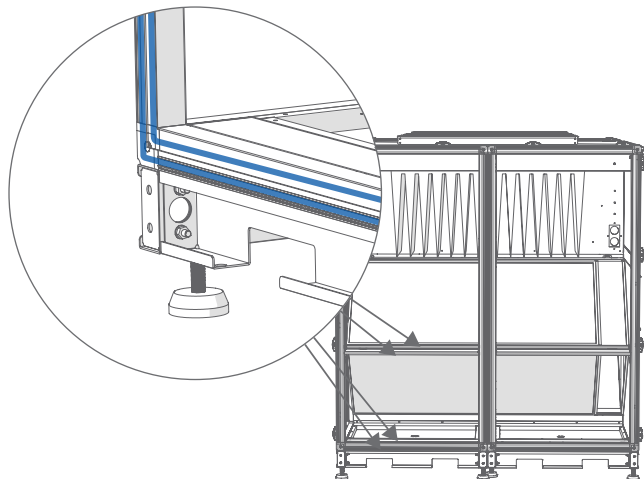

DANGER
Mortal danger caused by an electric shock!

An electric shock could result in death or serious injury. Make sure the unit is dead and disconnected from power. Earth and short-circuit the unit. Protect any adjacent live components.

Vallox Pureo TX 1300 and 1800 consist of three modules, delivered separately.

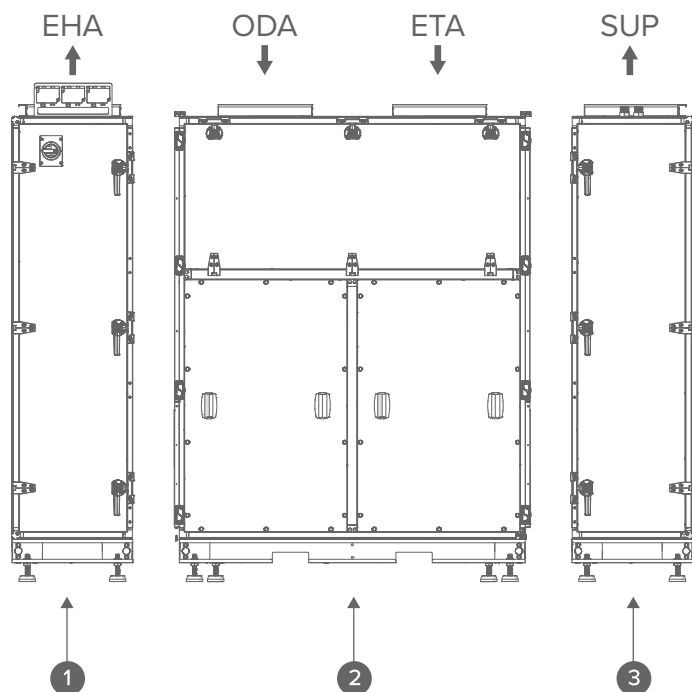

Before assembling the modules together at the final place of installation, place them as close to each other as possible. Use the base of each module to pull them together.

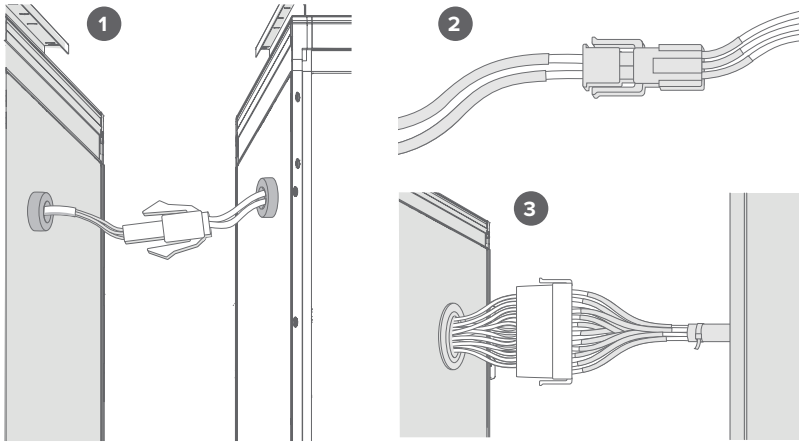

Make sure all the electrical connections have been done carefully:

1. ODA and ETA temperature sensor connections
2. Damper motor connections
3. Mains connection

Make sure the pressure hoses have been connected correctly according to their markings.

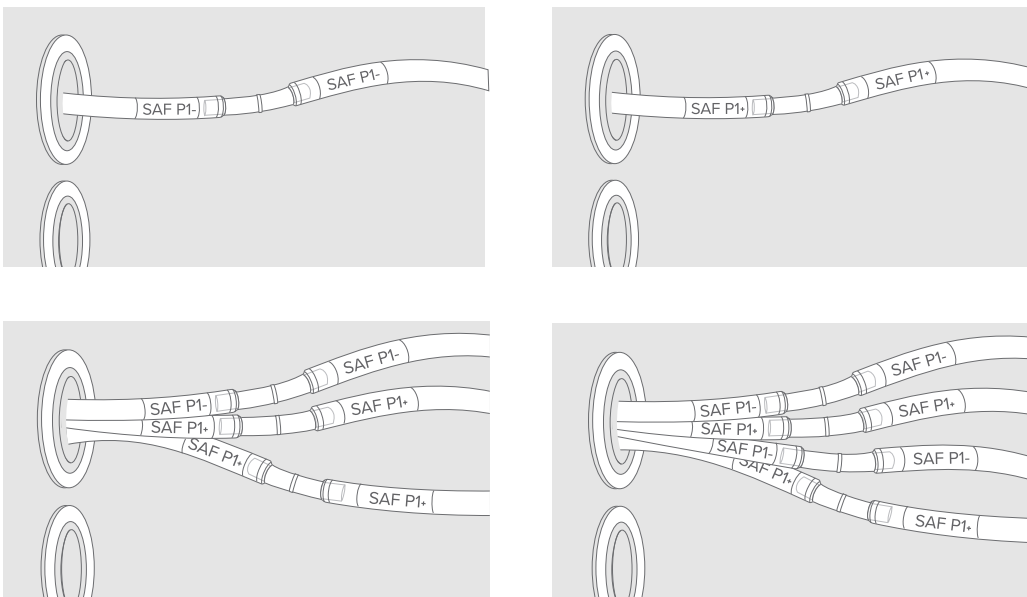

Before assembling the unit, place all the modules as close to each other as possible. Use the base of each module to pull them together. Pull the modules close to each other and tighten with screws.

1. Move the modules as close to each other as possible.
2. Push them from the base only.
3. Press the modules together and tighten with screws.
4. To finish, make sure all the modules have been connected. Tighten with screws.

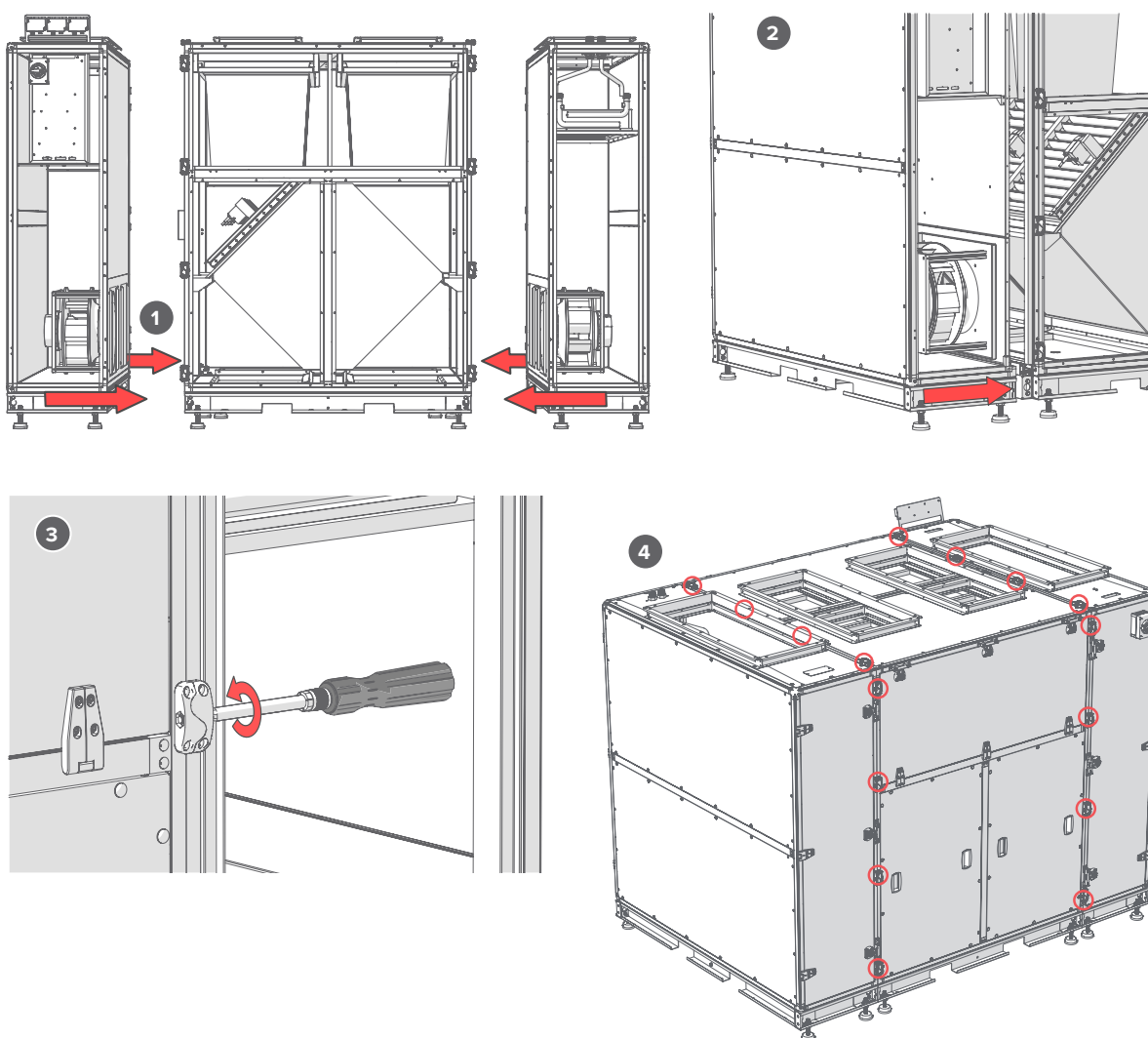

Flange connections and adapters

The dimensions of the unit's flange connections have been listed in the table below.

	Dimensions (mm)						
	R	S	T	U	V	W	n
Vallox Pureo TX 1300	832	432	804,4	400	422,2	256,3	8
Vallox Pureo TX 1800	1032	432	1004,4	400	422,2	323	8



NOTE
The ducts must be secured tightly to the connection valves.

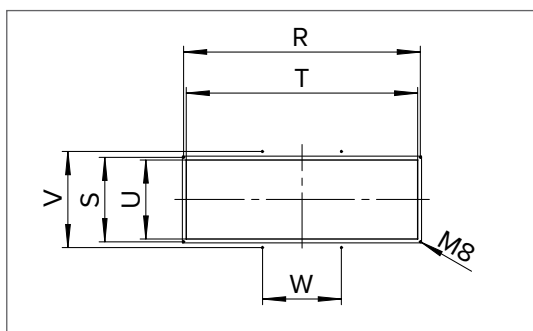

Connect the ducts, connector and flexible duct to the unit corners with M8x16 screws.

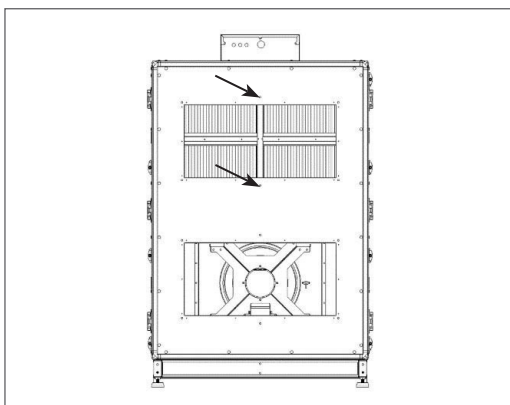

NOTE
After tightening the screws, the accessory must be secured with supports.

DUCT SYSTEM

Follow the local regulations on fireproofing and air ducts.

ELECTRICAL CONNECTIONS



DANGER

Mortal danger caused by an electric shock!

The unit must be fully isolated from the mains before carrying out maintenance and installation work and before opening the connection box! Electrical connections shall be made by a qualified electrician only according to the wiring diagram used. Electrical connections must be fully isolated from the main power source until the final assembly!

The unit has a main switch and an insulator, which has been protected against unauthorised use with a D-lock. Applicable standards, safety regulations, and technical requirements set for the connection by the local electricity company shall be complied with. The unit is connected to the mains through the connection box or the main switch. The unit controller (not included in the standard delivery) is connected to the unit with a cable provided with the controller. The Vallox Pureo control panel is connected to the unit with a cable. The control cable should not be longer than 10 metres. The unit shall be classified as “professional equipment” according to the applicable standard. A low-voltage connection is allowed if discussed in advance with the electrical contractor.



NOTE!

The following circuit breakers are recommended:

CIRCUIT BREAKERS			
	Phase	Type	Circuit breakers (A)
Vallox Pureo TX 350	~1	C	6
Vallox Pureo TX 500	~1	C	16
Vallox Pureo TX 900	~3	C	16
Vallox Pureo TX 1300	~3	C	16
Vallox Pureo TX 1800	~3	C	16

For more information about the connection of optional components to the mains, please see the instructions for installation and use of said component.

MAINS CONNECTION

1. Open the connection box cover.
2. Check the diameter of the cable used for the mains connection.
3. Loosen the cable gland and slip the cables through it.

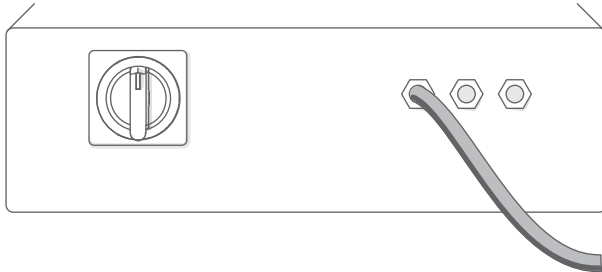

4. Connect the cables to the correct connectors.

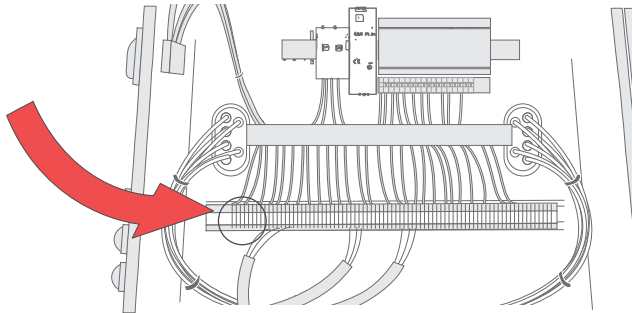

Vallox Pureo TX 1300 and 1800

1. See the instructions for main switch installation on the next page.
2. Check the diameter of the cable used for the mains connection.
3. Pull the cable to the correct main switch.
4. Connect the cables to the connectors. See the wiring diagram for the connection points.

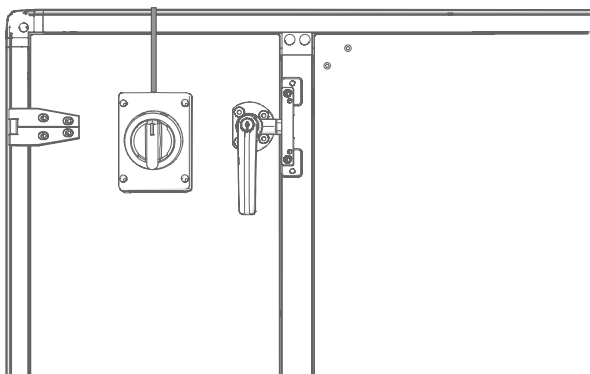

MAIN SWITCH INSTALLATION

Install the main switch by following these steps:

1. Determine the maintenance side of the unit.
2. Install the main switch to the unit's maintenance panel with a single M4x10 screw.

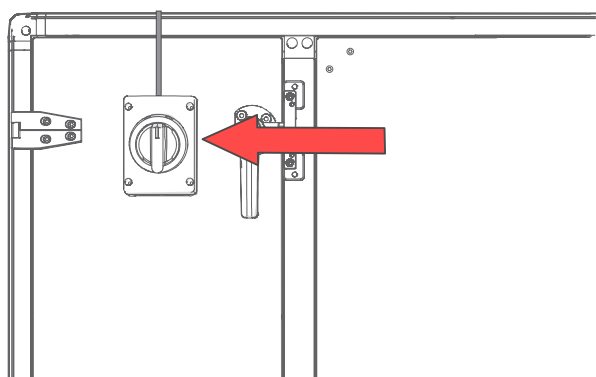

CONTROLLER CONNECTION

! DANGER
Mortal danger caused by an electric shock!

An electric shock could result in death or serious injury. Make sure the unit is dead and disconnected from power. Earth and short-circuit the unit. Protect any adjacent live components.

! WARNING
Danger due to an electric shock, moving parts (fan) and hot surfaces!

1. Open the connection box cover.



2. Loosen the cable gland and slip the cables through it.
3. Connect the control cable to the correct connectors on the connection box (see. Electrical connections).
4. Connect the other end of the HMI cable to the display(see. Electrical connections).

DIMENSIONS AND DUCT OUTLETS

Vallox Pureo TX 350

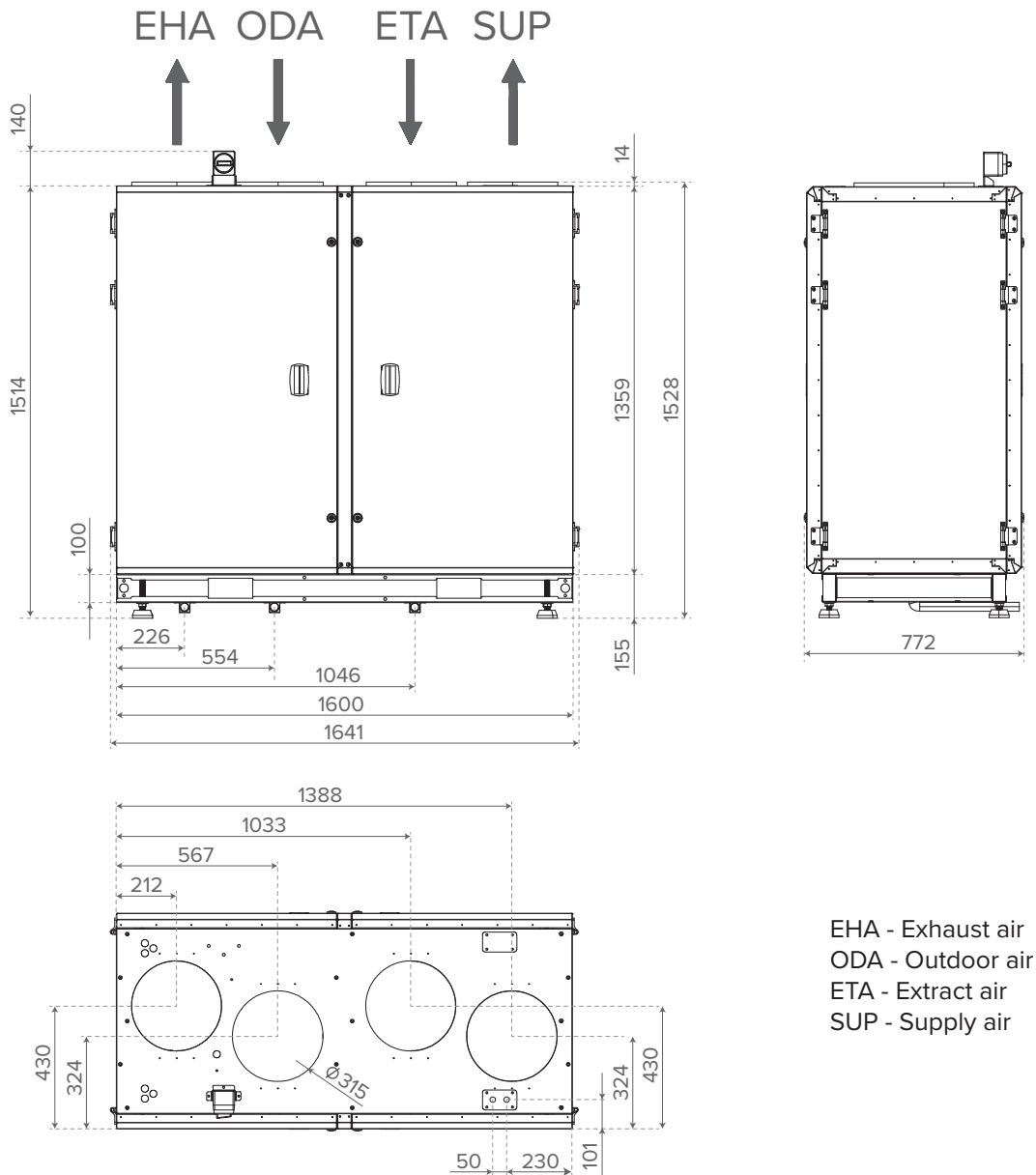

Vallox Pureo TX 500

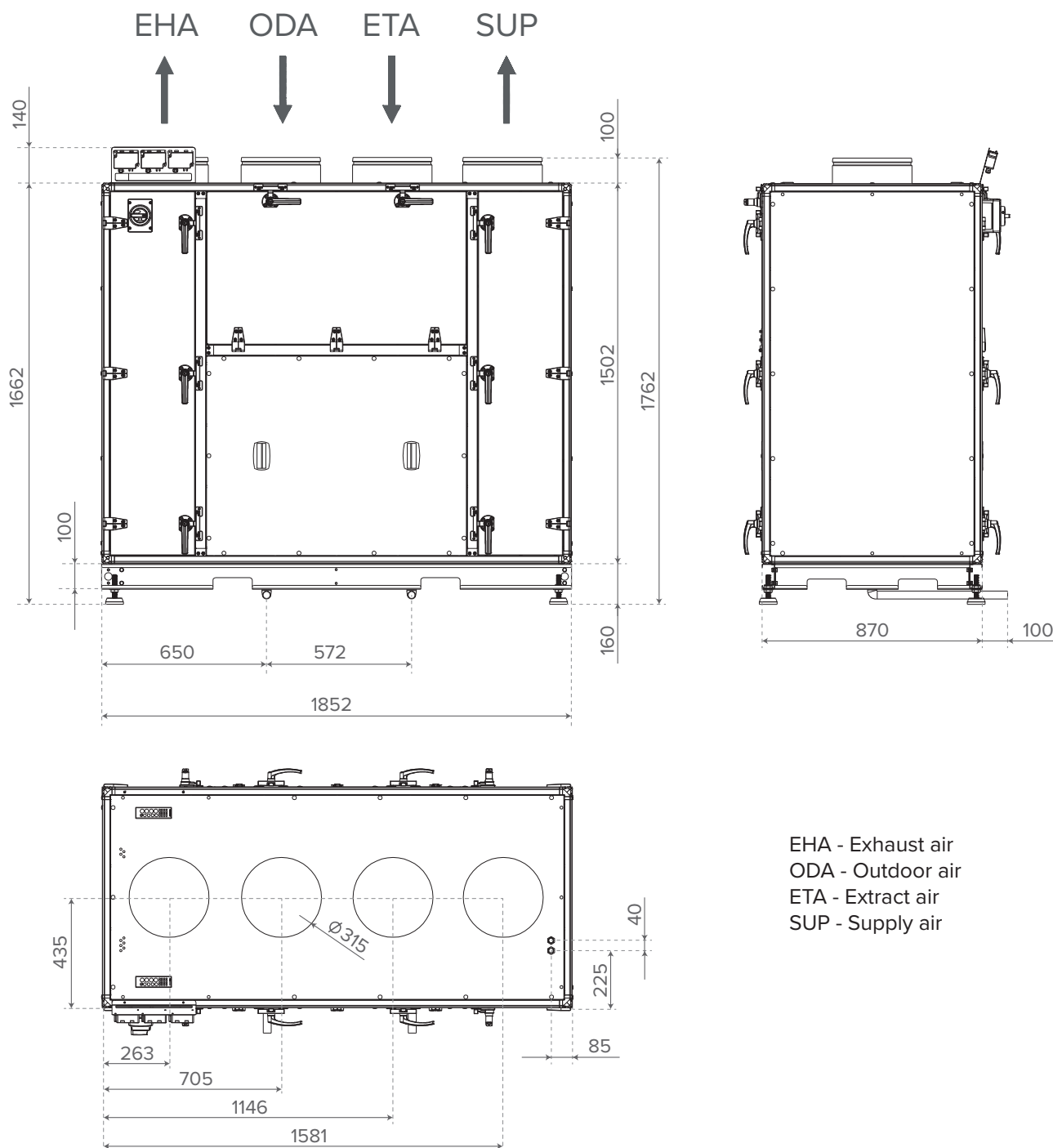

Vallox Pureo TX 900

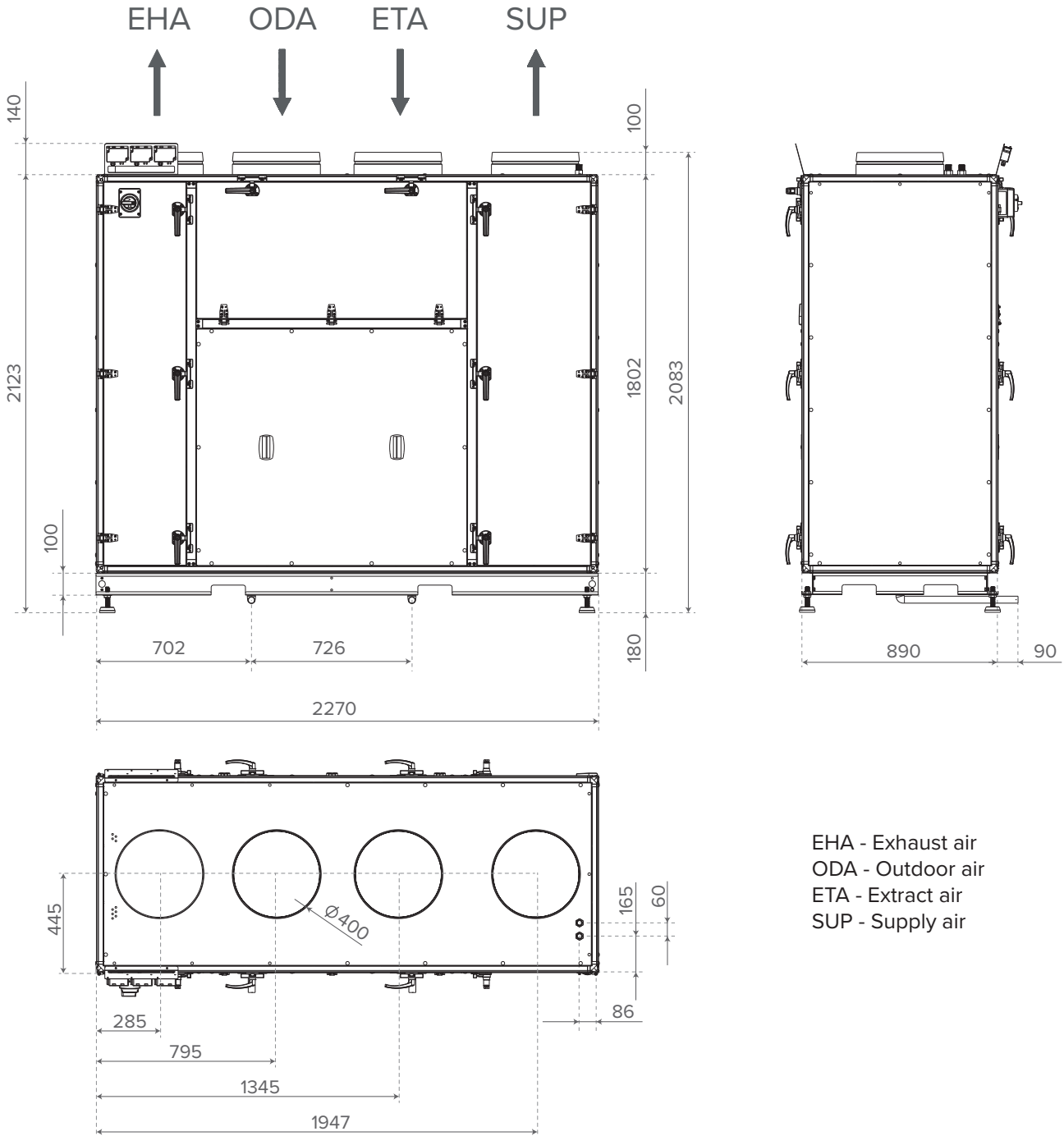

EHA - Exhaust air
ODA - Outdoor air
ETA - Extract air
SUP - Supply air

Vallox Pureo TX 1300

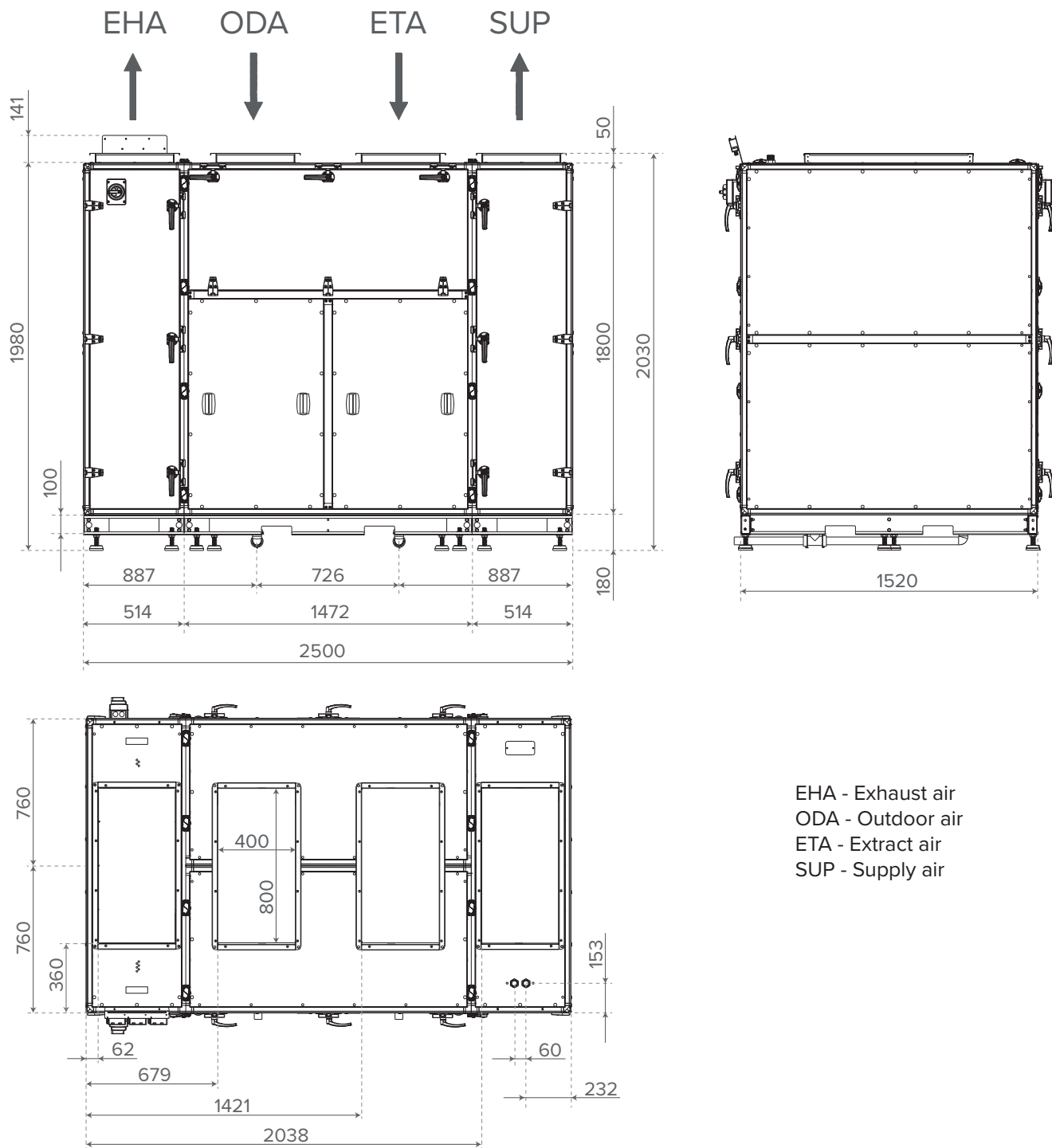

Vallox Pureo TX 1800

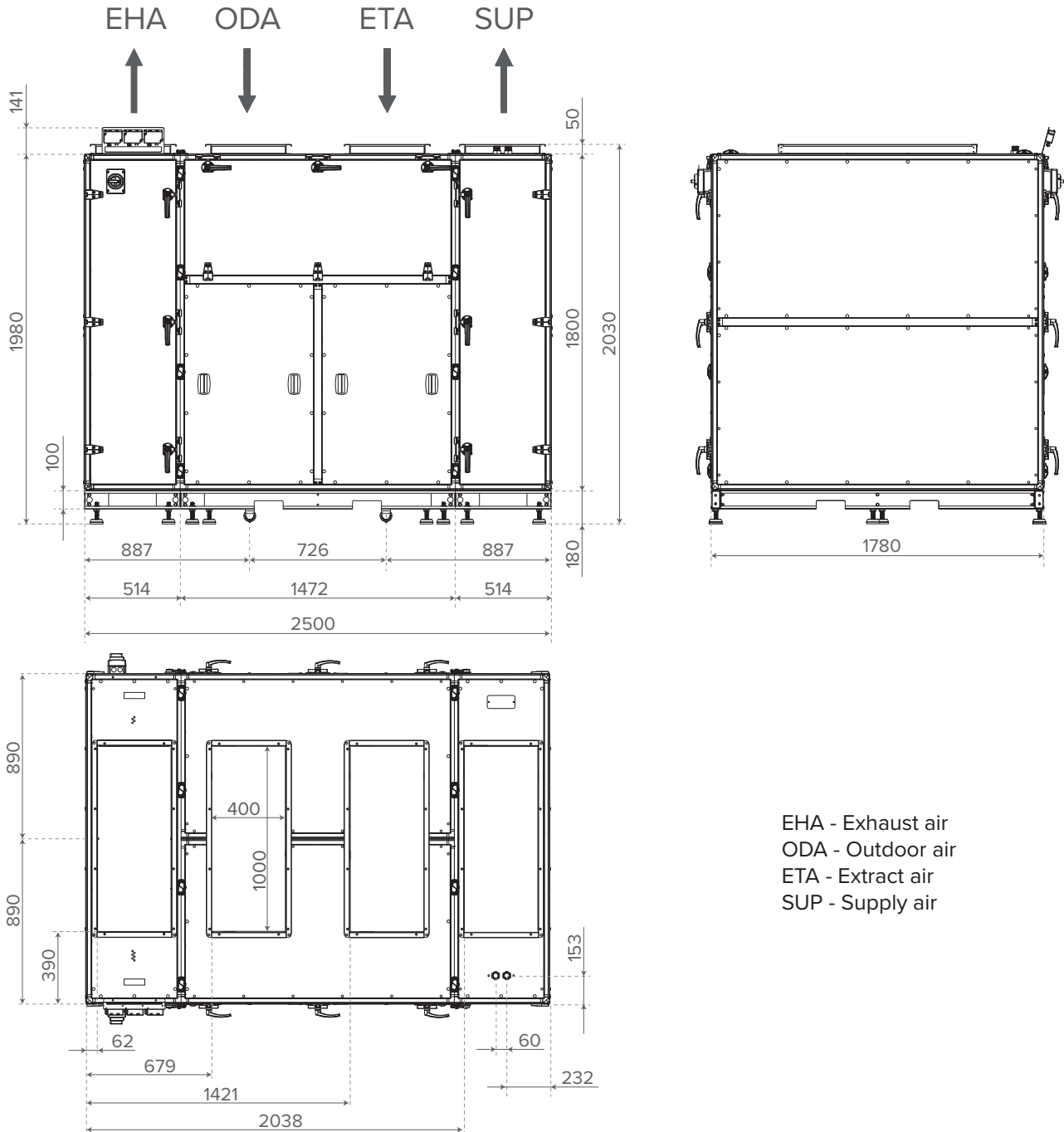

EHA - Exhaust air
ODA - Outdoor air
ETA - Extract air
SUP - Supply air

OPERATING CHARACTERISTICS

Available online at valloxselect.com.

SERVICE AND MAINTENANCE

The unit shall be cleaned and maintained by professionals only.

The unit must be fully isolated from the mains before carrying out maintenance and installation work and before opening the service door.



CAUTION
After cutting off the power, wait for five (5) minutes before starting maintenance work!



DANGER
Mortal danger caused by an electric shock!

MAINTENANCE PLAN

The unit must be fully isolated from the mains before carrying out maintenance and installation work and before opening the connection box! Electrical connections shall be made by a qualified electrician only according to the wiring diagram used. Electrical connections must be fully isolated from the main power source until the final assembly!



DANGER
Danger due to an electric shock, moving parts (fan) and hot surfaces!

The unit must be inspected regularly according to the maintenance plan:

MAINTENANCE PLAN					
Part	Measure (if necessary)	3 months	6 months	12 months	24 months
1. Outdoor air and exhaust air duct outlets					
Check for contamination, damage and corrosion	Clean and repair				X
2. Filters					
Check for harmful contamination and damage (leaks) and odours	Replace defective filters	X			
3. Air ducts					
Check the accessible areas for damage	Repair			X	
Check 2–3 typical locations for contamination, corrosion and condensation on the duct surface	Check the other duct areas for a need of cleaning (not only visible areas!)			X	
4. Fan					
Check for contamination, damage and corrosion	Clean and repair		X		
5. Heat exchanger					
Check the counterflow heat exchanger visually for contamination, damage and corrosion	Clean and repair		X		
Heating coil: Check for contamination, damage and corrosion and make sure the seals are tight	Clean and repair, replace	X			
Cooling coil (optional): Check the coil, droplet separator and condensate tray for contamination, damage and corrosion and make sure the seals are tight	Clean and repair	X			
Check the operation of the condensation outlet pipe and siphon	Clean and repair	X			
6. Casing					
Check for harmful contamination and damage (leaks) and odours	Clean and repair	X			

SERVICE AND MAINTENANCE OF THE CROSS COUNTERFLOW HEAT EXCHANGER

The unit must be fully isolated from the mains before carrying out maintenance and installation work and before opening the connection box! Danger due to an electric shock, moving parts (fan) and hot surfaces!



WARNING
The heat exchanger is very heavy and may contain condensate! Maintenance work shall always be carried out by at least two people!

DANGER
Mortal danger caused by an electric shock!

DISASSEMBLY

1. Loosen the screws and remove the maintenance panels.
2. Unplug the heat exchanger.
3. The profile must always be removed (Vallox Pureo TX 1300/1800) for heat exchanger maintenance. Remove the cover plates and loosen the screws.
4. Remove the profile carefully.

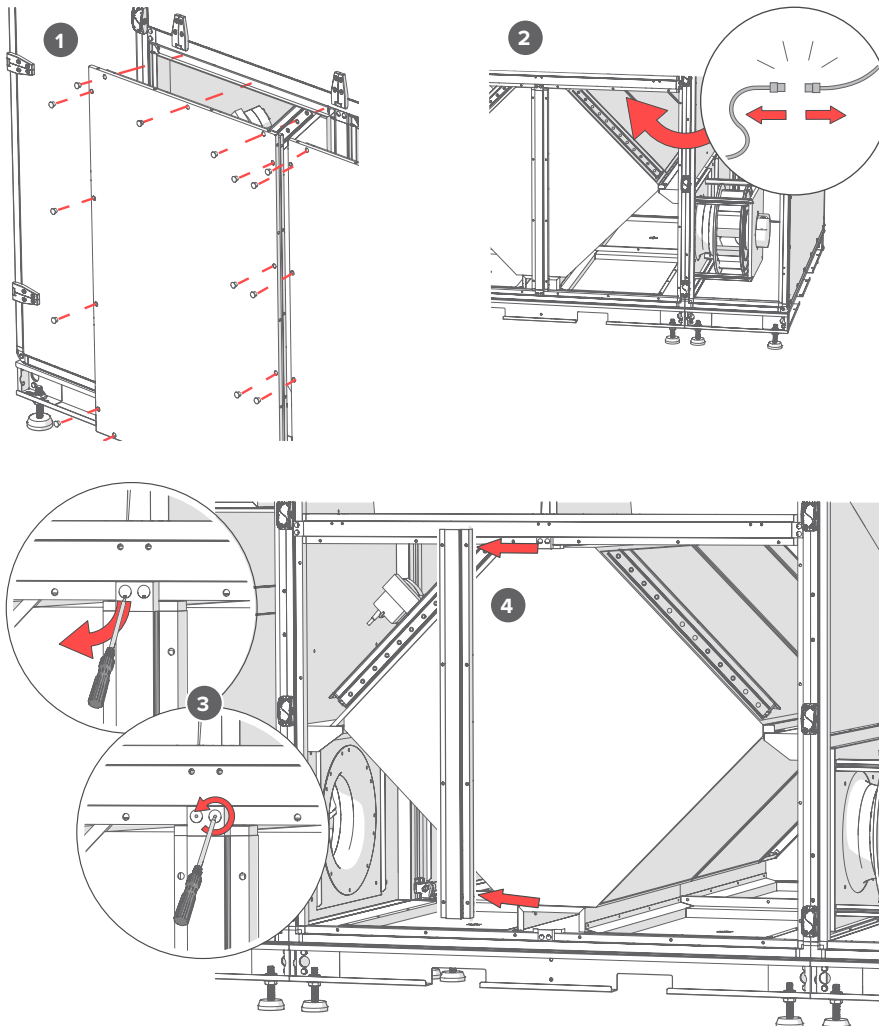

5. Pull the heat exchanger retainers forward and release them.
6. Remove the cross counterflow heat exchanger carefully and put it down safely.

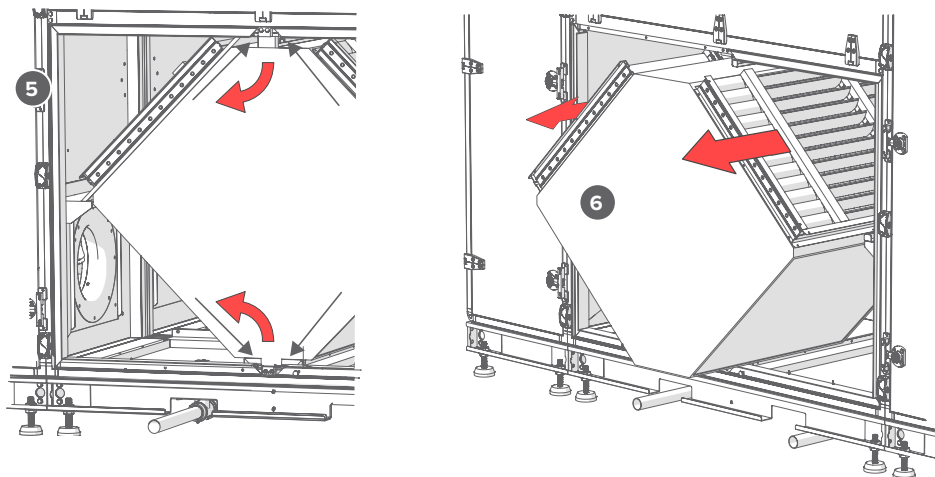

A forklift truck may be used to remove the cross counterflow heat exchanger from Vallox Pureo TX 1300 and 1800 units. Make sure to leave enough room for the forklift truck to maintain the heat exchanger.

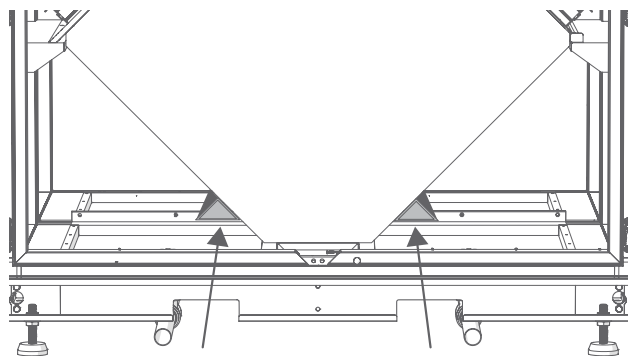

CLEANING

The cross counterflow heat exchanger must be inspected regularly for any dirt and dust. The cross counterflow heat exchanger must also be inspected for damage every six months. If the cross counterflow heat exchanger is dirty or dusty, follow these instructions to clean it:

- Aluminium cross counterflow heat exchangers may be cleaned with water (maximum permitted cleaning pressure 5 bar).
- You can use either cold or warm water (max. 70°C). A regular household cleaning agent may be used.
- Make sure to clean both sides of the heat exchanger!
- Do not bend the plates!
- When cleaning the heat exchanger, make sure to not damage it mechanically or chemically.



IMPORTANT
Allow the heat exchanger to dry before installation!

FILTER REPLACEMENT

The unit must be fully isolated from the mains before maintenance and cleaning.

The filters must be inspected for dirt, damage and odours every three months. If the filters are damp or mouldy, replace them immediately.

Vallox Pureo TX units are equipped with an ePM₁ 60% filter for outdoor air and ePM₁₀ 60% for extract air. If other types of filters are used, the settings of the unit controller must be changed.



DANGER

Mortal danger caused by an electric shock!

The technical specifications of a standard filter are listed in the table below:

1. Open the doors by releasing the retainer and turning the handles anticlockwise.
2. Release the filter by pulling at the retainer.
3. Remove the filter.

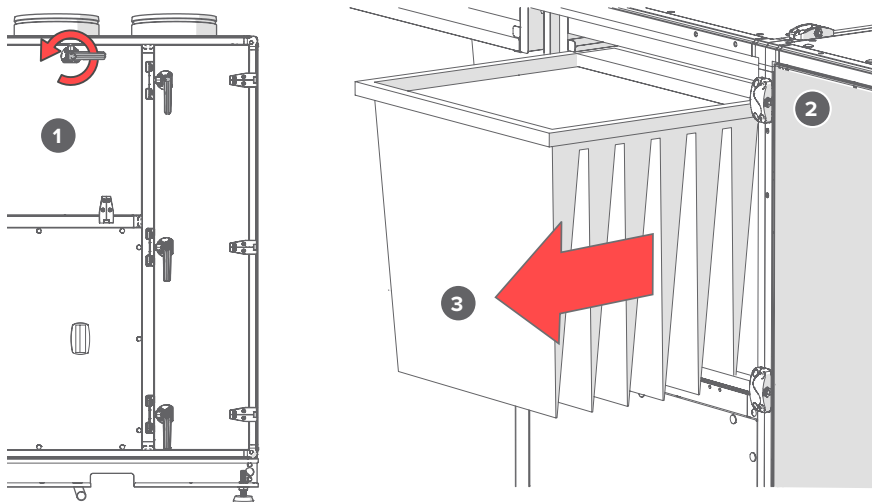

IMPORTANT

Check the air flow direction when installing the filter.



NOTE

Replacement filters are also available online at filters.vallox.com

TECHNICAL DATA FOR STANDARD FILTERS

	Filters	Nominal air volume flow (dm ³ /s)	Number of filters	Filter class	Dimensions (mm) (l x h x w)	Recommended final pressure differential (Pa)
Vallox Pureo TX 350	Extract air	350	1	ePM ₁₀ 60 %	648 x 96 x 382	94
Vallox Pureo TX 350	Outdoor air	350	1	ePM ₁ 60 %	648 x 96 x 382	147
Vallox Pureo TX 500	Extract air	500	1	ePM ₁₀ 60 %	490 x 592 x 535	120
Vallox Pureo TX 500	Outdoor air	500	1	ePM ₁ 60 %	490 x 592 x 535	174
Vallox Pureo TX 900	Extract air	900	1	ePM ₁₀ 60 %	592 x 592 x 535	120
Vallox Pureo TX 900	Outdoor air	900	1	ePM ₁ 60 %	592 x 592 x 535	174
Vallox Pureo TX 1300	Extract air	1300	1	ePM ₁₀ 60 %	592 x 592 x 535	120
Vallox Pureo TX 1300	Extract air	1300	1	ePM ₁₀ 60 %	287 x 592 x 535	120
Vallox Pureo TX 1300	Outdoor air	1300	1	ePM ₁ 60 %	592 x 592 x 535	174
Vallox Pureo TX 1300	Outdoor air	1300	1	ePM ₁ 60 %	287 x 592 x 535	174
Vallox Pureo TX 1800	Extract air	1800	2	ePM ₁₀ 60 %	592 x 592 x 535	120
Vallox Pureo TX 1800	Outdoor air	1800	2	ePM ₁ 60 %	287 x 592 x 535	174

SERVICE AND MAINTENANCE OF FANS

The unit must be fully isolated from the mains before maintenance and cleaning. Risk of injury due to an electric shock, moving parts (fan) and hot surfaces!



WARNING

Mortal danger caused by an electric shock!

Be careful when carrying out maintenance work – the fans are very heavy. The fans must be inspected for dirt, damage and corrosion every six months or more frequently, depending on the dirtiness of the blades:

- Regular inspections and cleaning carried out whenever necessary help prevent imbalance caused by dirt.
- Clean the fan casing.
- Make sure the unit does not vibrate or move.
- Wipe the fan clean with a damp cloth. Do not use corrosive agents that could damage the paint. It is prohibited to use a pressure washer and a water jet to clean the fan.
- If water enters the motor: dry the fan carefully before restarting the unit.



WARNING

Risk of injury due to the weight of the unit!

K FACTORS

Vallox Pureo TX 350	60
Vallox Pureo TX 500	60
Vallox Pureo TX 900	121
Vallox Pureo TX 1300	154
Vallox Pureo TX 1800	197

1. Open the doors by releasing the retainer and turning the handles anticlockwise.
2. Disconnect the fan connector.
3. Disconnect the pressure hoses from the fan.
4. Remove the fan slowly with care.

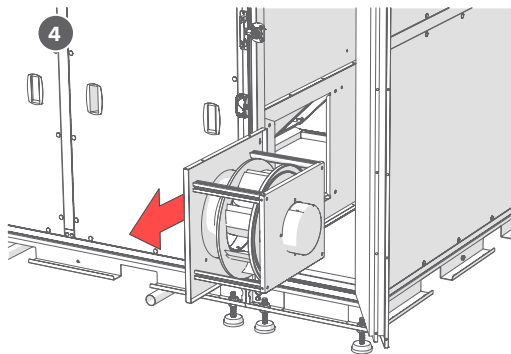
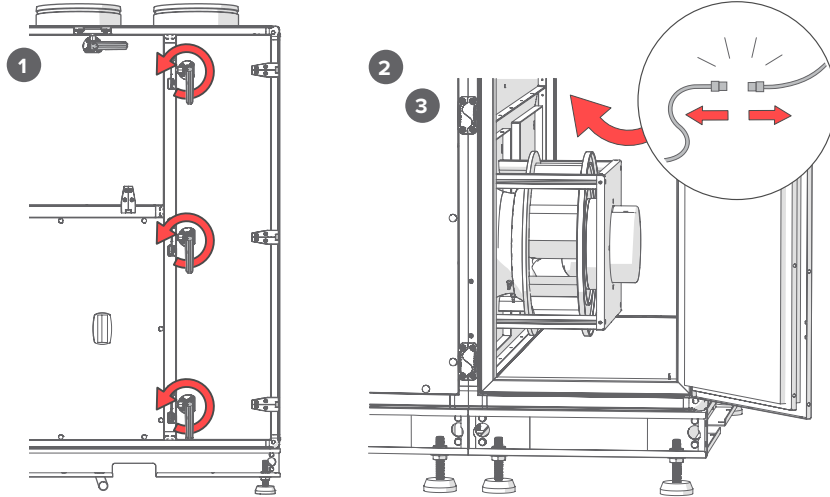

NOTE
When installing the fan, pay attention to the electrical connections and the correct connection of the pressure hoses.

CLEANING THE CONDENSATE TRAY

The unit must be fully isolated from the mains before maintenance and cleaning. Risk of injury due to an electric shock, moving parts (fan) and hot surfaces! If a condensate pump is installed, remove the pump connections before removing the service door. The condensate tray must be inspected for dirt and damage every six months.

 **DANGER**
Mortal danger caused by an electric shock!

1. Loosen the screws and remove the maintenance panels.
2. Wipe the condensate tray clean with a cloth.

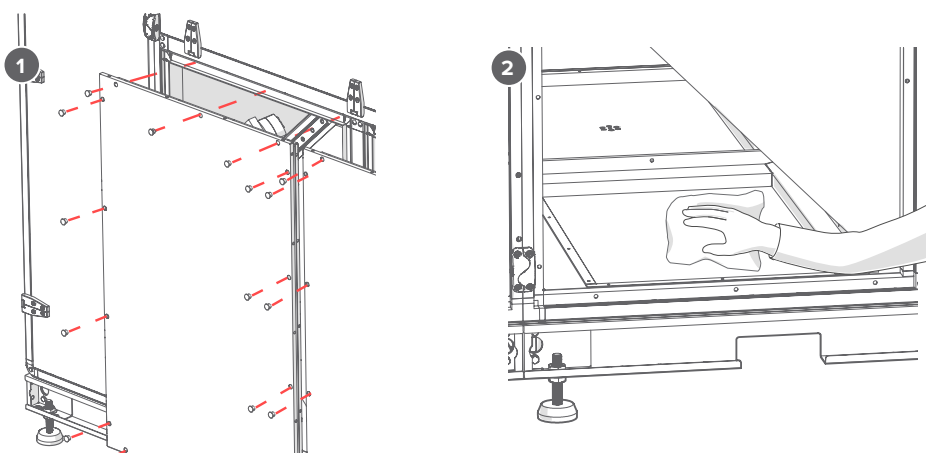

 **NOTE!**
Clean the condensate tray behind the maintenance hatch of the extract air fan of the Vallox Pureo TX 350 unit, if it is in use.

CLEANING THE UNIT

The unit must be fully isolated from the mains before maintenance and cleaning. Risk of injury due to an electric shock, moving parts (fan) and hot surfaces!

- The unit must be inspected for dirt, damage and corrosion once a year.
- Wipe the unit clean with a damp cloth.

 **DANGER**
Mortal danger caused by an electric shock!

PERFORMANCE AND TECHNICAL SPECIFICATIONS

Rating details and technical specifications are available in the selection software. Available online at valloxselect.com.

The mechanical connections must be made correctly to achieve the best possible performance results. The unit's thermal efficiency, noise level and electrical performance could vary depending on the operating conditions. The operating conditions could impact the on-site values, which could differ from the values specified in the selection software.

EXPLODED VIEWS AND PARTS LISTS

Vallox Pureo TX 350

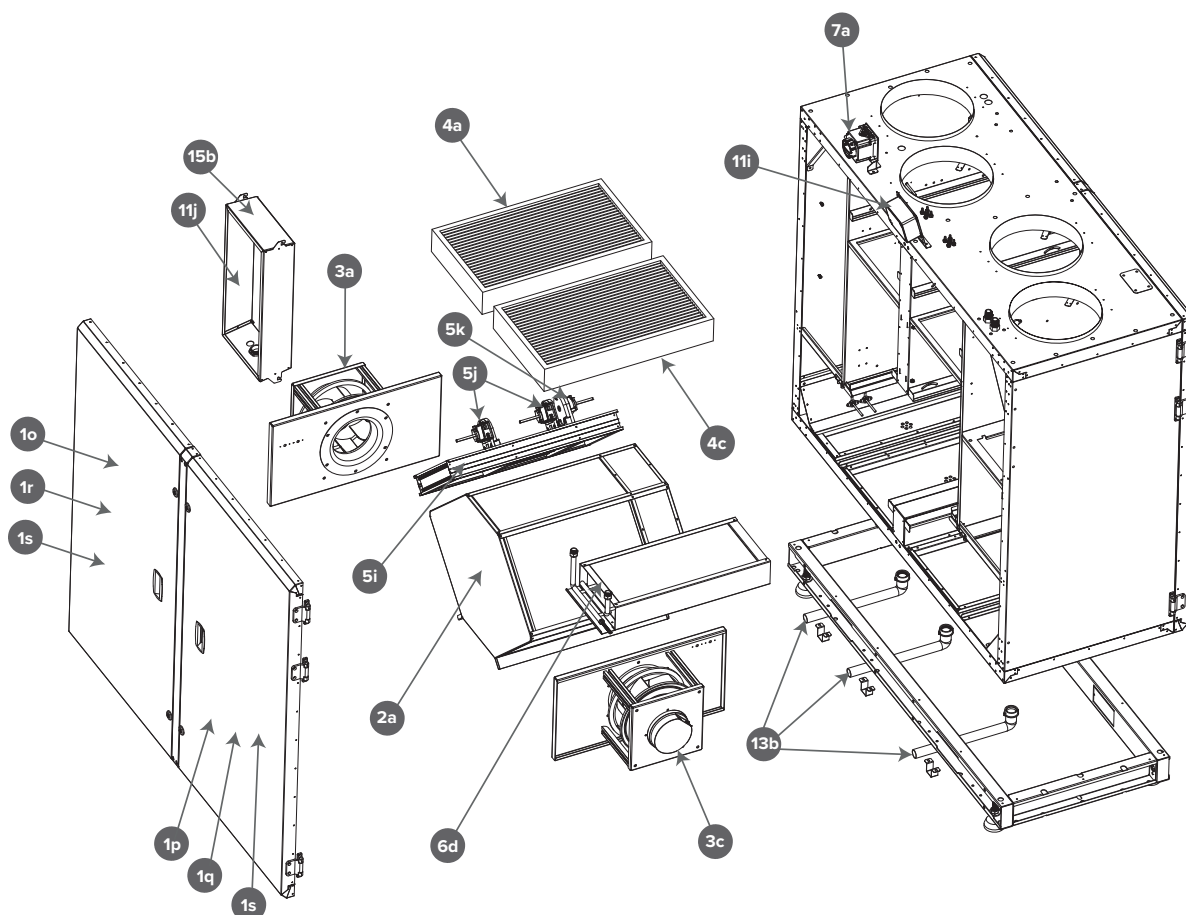

NO	PART	NO	PART	NO	PART
1o	Maintenance hatch of the supply air filter	3c	Extract air fan	7a	Main switch
1p	Maintenance hatch of the extract air filter	4a	Supply air filter	11i	Pressure transmitter
1q	Maintenance hatch of the supply air fan	4c	Extract air filter	11j	Controller
1r	Maintenance hatch of the extract air fan	5i	Bypass/sectional defrosting dampers	13b	Condensation outlet pipe
1s	Maintenance hatch of the counterflow heat exchanger	5j	Actuator of the sectional defrosting dampers	15b	Electrical box
2a	Counterflow heat exchanger with bypass	5k	Bypass actuator		
3a	Supply air fan	6d	Post-heater (liquid)		

Vallox Pureo TX 500/900

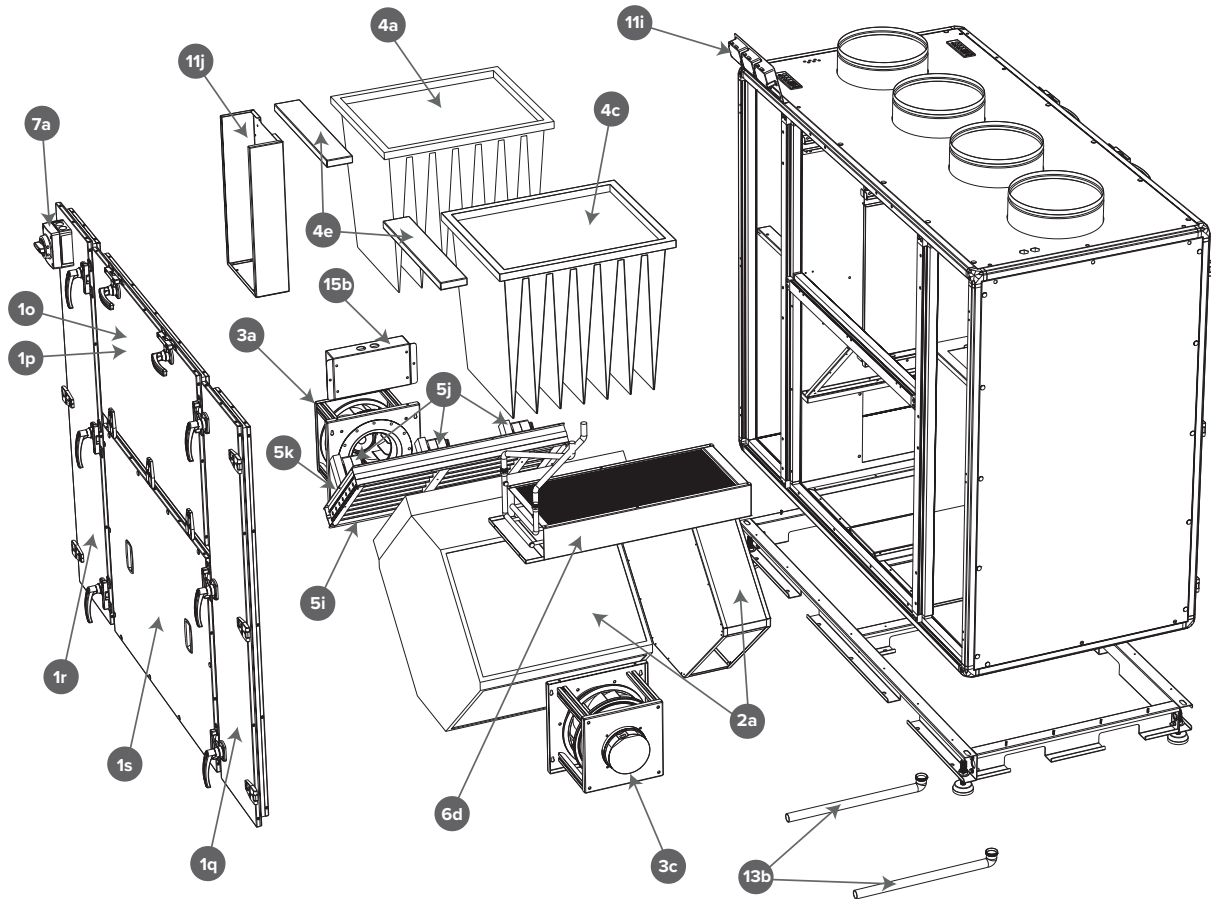

NO	PART	NO	PART	NO	PART
1o	Maintenance hatch of the supply air filter	3c	Extract air fan	7a	Main switch
1p	Maintenance hatch of the extract air filter	4a	Supply air filter	11i	Pressure transmitter
1q	Maintenance hatch of the supply air fan	4c	Extract air filter	11j	Controller
1r	Maintenance hatch of the extract air fan	5i	Bypass/sectional defrosting dampers	13b	Condensation outlet pipe
1s	Maintenance hatch of the counterflow heat exchanger	5j	Actuator of the sectional defrosting dampers	15b	Electrical box
2a	Counterflow heat exchanger with bypass	5k	Bypass actuator		
3a	Supply air fan	6d	Post-heater (liquid)		

Vallox Pureo TX 1300/1800

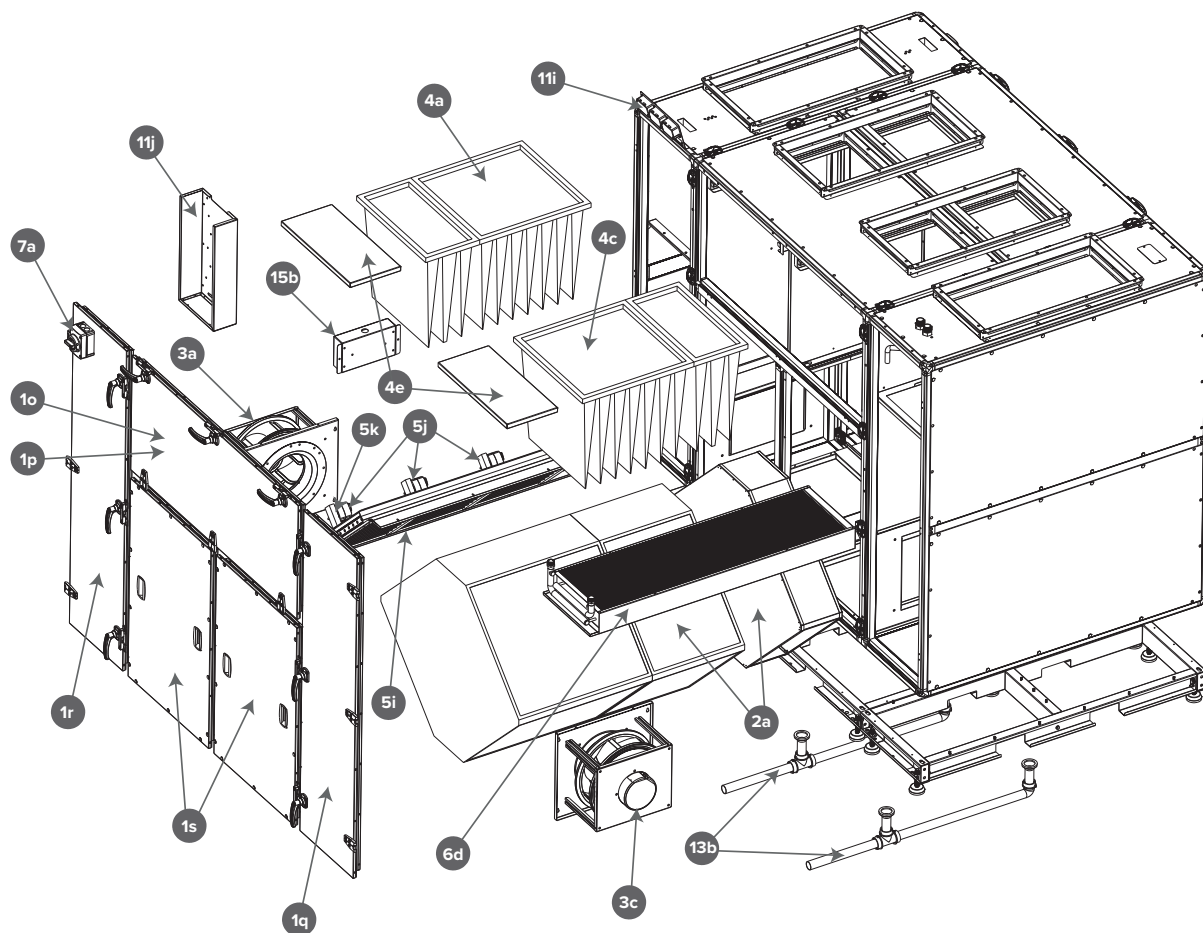

NO	PART	NO	PART	NO	PART
1o	Maintenance hatch of the supply air filter	3c	Extract air fan	7a	Main switch
1p	Maintenance hatch of the extract air filter	4a	Supply air filter	11i	Pressure transmitter
1q	Maintenance hatch of the supply air fan	4c	Extract air filter	11j	Controller
1r	Maintenance hatch of the extract air fan	5i	Bypass/sectional defrosting dampers	13b	Condensation outlet pipe
1s	Maintenance hatch of the counterflow heat exchanger	5j	Actuator of the sectional defrosting dampers	15b	Electrical box
2a	Counterflow heat exchanger with bypass	5k	Bypass actuator		
3a	Supply air fan	6d	Post-heater (liquid)		

DEVICE CONNECTIONS

Terminal block TX 350	Terminal block TX 500-1800	Pureo 5ch differential pressure transmitter		Device
1	1	24V -	Blue	1
2	2	24V +	Red	~
A	A	A	White	A
B	B	B	Yellow	B

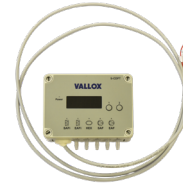

Ouman 5-CDPT

Terminal block TX 350	Terminal block TX 500-1800	Pureo controller		Device
1	1	24V -	Blue	1
2	2	24V +	Yellow	2
A	A	A	Red	A
B	B	B	White	B

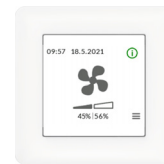

Ouman RU-23

Terminal block TX 350	Terminal block TX 500-1800	Duct damper actuators		Device
3	3	24V -	Black	1
4	4	24V +	Red	2



Belimo LF24

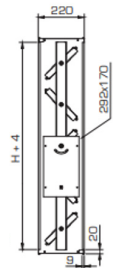

Terminal block TX 350	Terminal block TX 500-1800	Electrical post-heater control		Device
11	14	0-10V		10
12	15	GND		9

CV ...-3MQXL / CV ...-3MQYL / CV ...-3MQCL **400V 3N~**

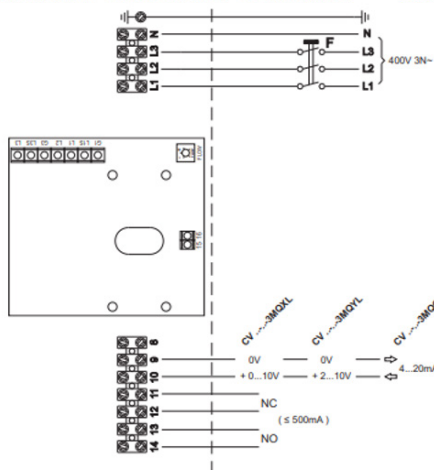

VEAB CV/VFL - MQXL

On-site cabling SU.

NOTE! Supply voltage directly from the electrical cabinet. Separate safety switch.

Terminal block TX 350	Terminal block TX 500-1800	Electrical intake air heater control		Device
5	8	0-10V		10
6	9	GND		9

On-site cabling SU.

NOTE! Supply voltage directly from the electrical cabinet. Separate safety switch.

Terminal block TX 350	Terminal block TX 500-1800	Cooling coil actuator	Device
7	10	24V -	1
8	11	24V +	2
9	12	0-10V	3
10	13		



Belimo NRYD24-SR-HW

Wiring diagrams

AC/DC 24V, voltage-controlled

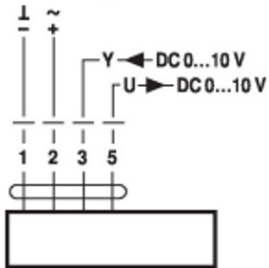

Cable colours:
1 = black
2 = red
3 = white
5 = orange

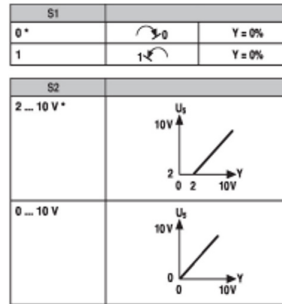
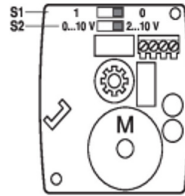

Terminal block TX 350	Terminal block TX 500-1800	Heating coil actuator	Device
7	10	24V -	5
8	11	24V +	6
11	14	0-10V	4
12	15		



ESBE Series ARA639

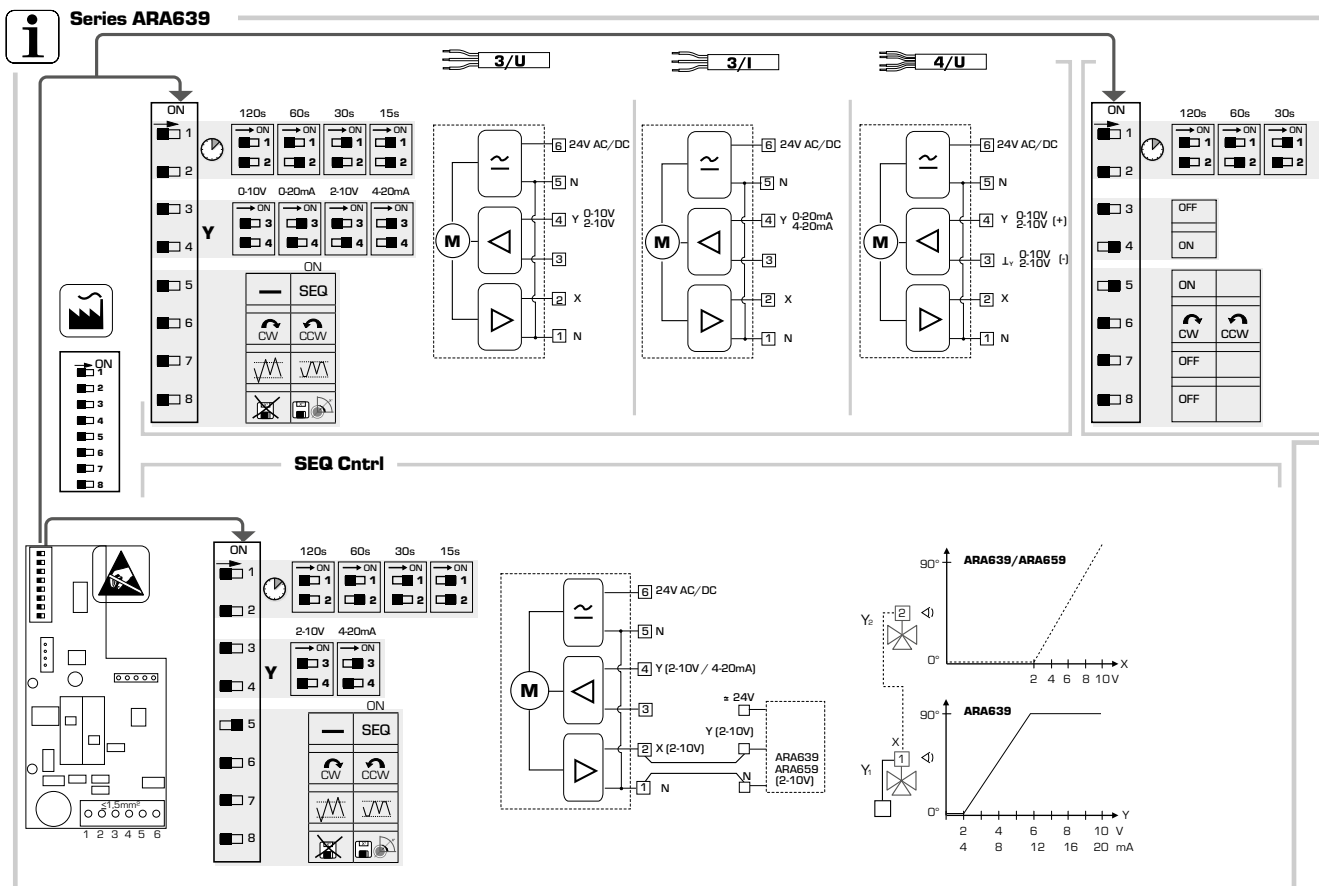

On-site cabling SU.

NOTE! Supply voltage for the circulation pump directly from the electrical cabinet. Separate safety switch.

Terminal block TX 350	Terminal block TX 500-1800	CO2 transmitter	Device
7	10	24V -	G0
8	11	24V +	G
13	16	0-10V	Y1
14	17		



Produl HDK-N

CAUTION: Device wiring and commissioning can only be carried out by qualified professionals. Always make the wirings while the power is switched off.

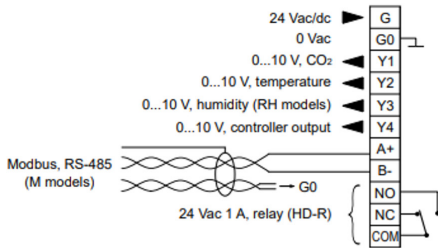

Terminal block TX 350	Terminal block TX 500-1800	VOC transmitter	Device
7	10	24V -	G0
8	11	24V +	G
15	18	0-10V	Y1
16	19		



Produl ILK-N

CAUTION: Device wiring and commissioning can only be carried out by qualified professionals. Always make the wirings while the power is switched off.

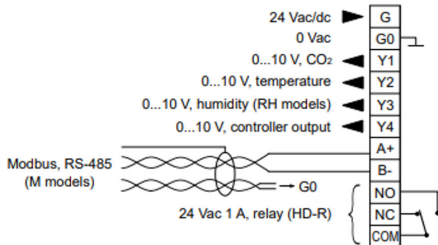

Terminal block TX 350	Terminal block TX 500-1800	Outdoor air temperature in the duct	Device
19	22	0-10V	1
20	23	GND	2



Ouman TMD

Terminal block TX 350	Terminal block TX 500-1800	Supply air temperature in the duct	Device
21	24	0-10V	1
22	25	GND	2



Ouman TMD

Terminal block TX 350	Terminal block TX 500-1800	Pressure transmitter for the supply air duct	Device
7	10	24V -	GND
8	11	24V +	24VDC
23	26	0-10V	0-10V
24	27		

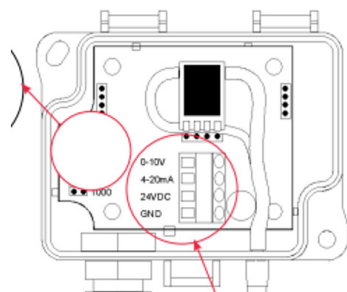

Pressure area selected 0-500 Pa



Ouman DPT-T

Terminal block TX 350	Terminal block TX 500-1800	Pressure transmitter for the extract air duct	Device
7	10	24V -	GND
8	11	24V +	24VDC
25	28	0-10V	0-10V
26	29		

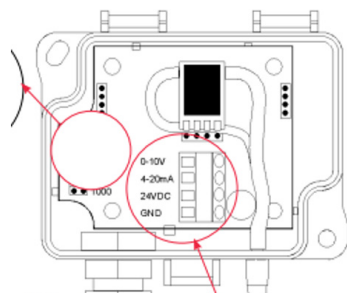

Pressure area selected 0-500 Pa



Ouman DPT-T

Terminal block TX 350	Terminal block TX 500-1800	Additional timer
7	10	
8	11	
27	30	
28	31	



E.g. Produl LxE

The LAP xE electronic timer is suitable for e.g. controlling boosted ventilation. Press the button to set the time. The indicators show the time set.

Connection

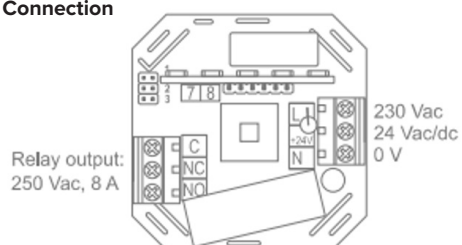

Terminal block TX 350	Terminal block TX 500-1800	Emergency stop
29	32	
30	33	

Short circuit as a factory setting

EC DECLARATION OF CONFORMITY

Manufacturer Vallox Oy
Myllykyläntie 9-11, FIN-32200 LOIMAA, FINLAND
Tel. +358 10 7732 200, Fax +358 10 7732 201

Declares that:

Description of unit Air handling unit
Model Vallox Pureo TX 350, Vallox Pureo TX 500, Vallox Pureo TX 900, Vallox Pureo TX 1300, Vallox Pureo TX 1800 and accessories for each respective size that fall within the scope of these directives.

If the product is installed correctly and used to its intended purpose, it conforms to below standards and directives at its date of manufacture.

Directives

1. Machinery Directive 2006/42/EC
2. Low Voltage Directive 2014/35/EU
3. EMC Directive 2014/30/EU
4. Restriction of Hazardous Substances (RoHS) Directive 2011/65/EU
5. Eco-design (Commission regulation (EU) No. 1253/2014) 2009/125/EC

Standards

1. SFS-EN JSO 12100:2010 Safety of machinery. General principles for design. Risk assessment and risk reduction
2. EN60204-1 Safety of machinery. Electrical equipment of machines. General requirements
3. EN 61000-6-3 Electromagnetic compatibility (EMC). Generic standards. Emission standard for residential, commercial and light-industrial environments
4. EN13053:2019 Air handling units - Rating and performance for units, components and sections
5. EN1886:2007 Ventilation for buildings - Air handling units - Mechanical performance

The person who compiles the technical file Juho Mäki
Vallox Oy
Myllykyläntie 9-11, FIN-32200 LOIMAA, FINLAND
Tel. +358 107 732 296
Fax +358 10 7732 201
Email juho.maki@vallox.com

This declaration relates exclusively to the machinery in the state in which it was placed on the market and installed according to Vallox Oy's instructions. This declaration does not include components which are added or changes done subsequently to the unit.

This is the original Declaration of Conformity

Loimaa, 16th December 2025



Jukka-Pekka Korja
Managing Director

VALLOX

www.vallox.com

Vallox Oy | Myllykyläntie 9-11 | FI-32200 LOIMAA | FINLAND

D10660/13.03.2026