

Firmly at the top. Helios roof fans.



**GERMAN
DESIGN
AWARD
WINNER
2021**



- EC roof fans, diagonal outlet, DV EC



10ff

Over 150 types in horizontal and vertical outlet designs with AC and efficient EC technology, in explosion-proof, T120 and smoke extraction versions and with volume flows from 540 to 70 000 m³/h – individual solutions are offered for every construction project.

- EC roof fans, horizontal and vertical outlet, RD and VD



504ff

- AC roof fans, horizontal and vertical outlet, also in T120 and explosion-proof versions, RD and VD



526ff

- Smoke extraction roof fans B VDD



See TGA catalogue
Ref. no. 86979



- Accessories

For roof fans.

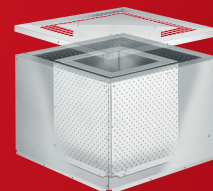

522ff



DV EC



This information supplements the "General technical information" and the information on the product page.

Series DV EC

Diagonal outlet centrifugal fans for exhaust air operation. With EC drive technology for energy-saving application and the lowest operating costs.

■ Design

Extremely weather-resistant EC roof fan in plastic design for an extensive area of application. Aerodynamically designed plastic casing made of grey polypropylene with diagonal air outlet direction. Air flow temperatures from -30 to +60 °C.

■ Drive

Energy-efficient EC external rotor motor in protection category IP54. Optimised efficiency, even with speed control for the lowest operating costs. Continuously variable speed control. Maintenance-free and radio interference-free, ball bearing mounted.

■ Impellers

Diagonal impeller made of aluminium, the motor-impeller unit is dynamically balanced for low-noise operation.

■ Contact protection

All units are delivered with an air outlet side protection grille according to DIN EN ISO 13857 as standard. If the system does not provide protection against touching rotating parts on the inlet side, a protection grille should also be attached here (Accessories).

■ Air flow temperatures

Air flow temperatures from -30 to +60 °C.

Power control
DV EC Pro

■ Ideal as a central exhaust air fan for multi-floor residential construction according to DIN 18017-3.

■ A complete central ventilation system according to DIN 18017-3 with demand-controlled ventilation can be constructed in combination with additional components (Accessories).

■ Integrated pressure control for volume flow stabilisation in the connected rooms through automatic speed adjustment with consistently good efficiency.

■ Integrated pressure sensor 0-300 Pa.

■ Short amortisation period due to high energy savings.

■ Operating data adjustment on the 4 potentiometers integrated in the control system for adjusting the desired operating point on site.

■ Integrated serial bus interface (RS 485) for connection to a PC/laptop in conjunction with the interface (Accessories).

Power control
DV EC Eco

■ All EC types have continuously variable speed control via potentiometer, universal control system or electronic differential pressure/temperature controller (in combination with the mains adapter NG 24, Accessories). Performance levels are shown on the performance curve as examples. Suitable control units can be found in the type table. Further information can be found in the "General technical information".

■ Electrical connection

Standard operating switch (protection category IP65) mounted on the outside of the casing. Connection voltage 1~, 230 V, 50 Hz.

■ Motor protection

Integrated electronic temperature monitoring system for EC motor and electronics.

■ Base formation, installation, delivery

The units are delivered ready for installation in individual shipping boxes or crates. The fans are quick and easy to install; they are equally suitable for mounting on flat, pitched, single pitch, saw-tooth, sloping, trapezoidal or arched roofs. In general, the roof bases must always be designed so that the fan base plate lies flat and horizontal.

We recommend the use of the flat roof base, sloping roof base or corrugated roof base offered in the accessories range. These bases reduce the costs for planning, design and installation to a minimum.

The bases can also be created on site e.g. from concrete, wood, bricks or the like. A horizontal and flat surface is just as indispensable as a proper seal with the roof edge. Once positioned, the base plate is fastened to the base with 4 screws.

Helios flat roof bases and base silencers NS 180-450 mm have a hinge mechanism which is beneficial when it comes to cleaning and inspection. With regard to on-site bases, spacers should be used to compensate for any unevenness.

A gap between the base plate and base should be sealed with elastic tape or similar material. Once the screws have been evenly tightened, check the

■ Noise

Further information can be found on the product pages and the "General technical information".

Reference	Page
Planning information, acoustics, explos. protection	14 ff.
General techn. information, power control	19 ff.

RD EC



VD EC



Series RD EC

Horizontal outlet EC centrifugal fans for exhaust air operation with efficiency-optimised aluminium casing and newly developed high-performance centrifugal impeller.

Series VD EC

Vertical outlet EC roof fan with efficiency-optimised aluminium casing and newly developed high-performance centrifugal impeller.

Common features RD EC and VD EC

■ Design

Robust and weather-resistant design. Motor support plate and base plate with inlet nozzle made of galvanised steel. Casing made of sea water-resistant aluminium with integrated tamper protection.

Base plate made of galvanised steel sheet with inlet nozzle made of aluminium for all explosion-proof types. Smooth running due to vibration-damping motor suspension. Flat design.

■ Drive

External rotor motors in protection category IP44, IP54, IP4X and insulation class F according to DIN EN 60034 / VDE 0530 and DIN EN 60335-1 / VDE 0700-1 are used for the EC types. The winding is also protected against moisture. The maintenance-free ball bearings have a lubricant supply for a period of approx. 30000 operating hours. Motor and impeller dynamically balanced as a unit according to DIN ISO 21940-11, quality grade 6.3 for low-vibration operation.

■ Impellers

High-performance centrifugal impellers with backward curved blades made of plastic, steel sheet or aluminium. Dynamically balanced according to DIN ISO 21940-11 – quality grade 6.3.

■ Contact protection

All units are delivered with an air outlet side protection grille according to DIN EN ISO 13857 as standard. If the system does not provide protection against touching rotating parts on the inlet side, a protection grille should also be attached here (Accessories).

■ Air flow temperatures

The range of application for EC types is up to +60 °C.

■ Power control

All EC types have continuously variable speed control via internal (delivery) or external potentiometer, universal control system or electronic differential pressure/temperature controller (in combination with the mains adapter NG24, Accessories). Performance levels are shown on the performance curve as examples. Suitable control units can be found in the type table. Further information can be found in the "General technical information".

■ Electrical connection

ND 180 – 250 to external terminal box in protection category IP65. ND 315 – 630 to external terminal box and isolator switch in protection category IP65.

■ Motor protection

Integrated electronic temperature monitoring system for EC motor and electronics.

■ Installation

The installation should be carried out horizontally with a maximum inclination of 5° (no inclination possible with Ex models). In the case of sloping roofs, this must be achieved by means of an appropriate base construction in order to prevent water ingress.

■ Delivery

Units are ready-for-connection, fully pre-assembled in the shipping box / wooden crate. Simple positioning with standard crane hook from ND 450 upwards.

■ Noise

Further information can be found on the product pages and the "General technical information".

Reference	Page
Planning information, acoustics, explos. protection	14 ff.
General techn. information, power control	19 ff.

RD



Also available
in version:



VD



Also available
in version:



Common features RD, VD and VD T120

■ Design

Robust and weather-resistant design. Motor support plate and base plate with inlet nozzle made of galvanised steel. Casing made of sea water-resistant aluminium with integrated tamper protection. Base plate made of galvanised steel sheet with inlet nozzle made of aluminium for all explosion-proof types. Smooth running due to vibration-damping motor suspension. Flat design.

■ Drive

Speed-controllable external rotor motors located inside the air flow in closed design and protection category IP44 or IP54 and insulation class F according to DIN EN 60034 / VDE 0530 and DIN EN 60335-1 / VDE 0700-1 are used for the AC types. The winding is also protected against moisture. The maintenance-free ball bearings have a lubricant supply for a period of approx. 30000 operating hours. Motor and impeller dynamically balanced as a unit according to DIN ISO 21940-11, quality grade 6.3 for low-vibration operation.

■ Impellers

High-performance centrifugal impellers with backward curved blades made of galvanised steel sheet, plastic or aluminium. Dynamically balanced according to DIN ISO 21940-11 – quality grade 6.3.

■ Contact protection

All units are delivered with an air outlet side protection grille according to DIN EN ISO 13857 as standard. If the system does not provide protection against touching rotating parts on the inlet side, a protection grille should also be attached here (Accessories).

■ Air flow temperatures

The units can be used in the range from -20 °C to $+70\text{ °C}$. The upper limit value is type-specific and can be found in the table on the product page. If the fan is speed-controllable, this value should be reduced by approx. 10 °C . Explosion-proof types are approved up to max. $+40\text{ °C}$. VD T120: The units can be used in the range from -30 °C up to max. $+120\text{ °C}$. Compliant with VDI 2052.

■ Power control

Further information can be found on the product pages and the “General technical information”. The voltage-controllable types can be identified by a value in the column “Current consumption with control”.

■ Electrical connection

The supply line can be connected from below via a cable opening in the base plate or from above (via the roof). The connection to the external terminal box or isolator switch must be carried out without dismantling other parts in accordance with the provided wiring diagram.

■ Motor protection

Further information can be found on the product pages and the “General technical information”.

■ Incorrect direction of rotation

The units are only suitable for exhaust air operation. Operation in the incorrect direction of rotation overloads the motor and causes the thermal contacts or PTC thermistor to respond. Typical concomitant features include virtually non-existent flow rate, vibration and abnormal noise.

■ Installation

The installation should be carried out horizontally with a maximum inclination of 5° (no inclination possible with Ex models). In the case of sloping roofs, this must be achieved by means of an appropriate base construction in order to prevent water ingress. See series DV EC for delivery and base formation.

■ Explosion protection

The explosion-proof types correspond to unit group II, category 3 G for use in zone 2 in accordance with Directive 2014/34/EU.

The explosion-proof types $\varnothing 315$ to $\varnothing 560$ correspond to unit group II, category 2G for use in zone 1 in accordance with Directive 2014/34/EU.

The EU declaration of conformity provided with each fan certifies the design according to DIN EN 60079-0 / VDE 0170-1 and DIN EN 60079-7 / VDE 0170-6. The protection category corresponds to Ex e 2G.

The temperature class is noted on the type page. The external terminal box also corresponds to Ex e 2G.

See “Planning information Explosion protection” and “General technical information” for further information.

In accordance with EU Directive 2014/34/EU, larger air gaps are required, which can lead to a performance reduction of up to 10 %.

■ Noise

Further information can be found on the product pages and the “General technical information”.

Reference	Page
Planning information, acoustics, explos. protection	14 ff.
General techn. information, power control	19 ff.

By combining the parameters of static pressure increase Δp_{fa} , speed min^{-1} and inlet side air noise as sound pressure at

4 m (free field conditions), the following table facilitates the selection of EC roof fans.

	Speed	Sound press. inlet side	Flow rate \dot{V} m ³ /h depending on static pressure = N / m^2 = freely available pressure														
	min^{-1}	L_{PA} dB(A)	(Δp_{fa}) in Pa														
		at 4 m dist.	0	50	100	150	200	250	300	350	400	450					
Type DV EC																	
DV EC 200	1810	50	2010	1830	1660	1480	1270	1030	720	350							
DV EC 250	1640	55	3700	3480	3210	2930	2700	2420	2090	1690	1240	240					
DV EC 400 A	1020	48	4070	3660	3220	2720	2200	1610	980								
DV EC 400 B	1425	60	5650	5470	5100	4760	4480	4150	3800	3440	3000	1870					

	Speed	Sound press. inlet side	Flow rate \dot{V} m ³ /h depending on static pressure = N / m^2 = freely available pressure														
	min^{-1}	L_{PA} dB(A)	(Δp_{fa}) in Pa														
		at 4 m dist.	0	50	100	150	200	300	400	500	600	700	800	1000			
Type RD EC																	
RDW EC 180	3360	57	670	650	620	600	570	500	410	260							
RDW EC 200	2650	57	1180	1120	1040	950	870	670	500	310							
RDW EC 225 A	2550	52	1310	1250	1160	1080	1000	810	600	370	160						
RDW EC 225 B	3020	60	1500	1440	1380	1330	1270	1150	1010	850	550						
RDW EC 250	2705	61	1890	1840	1790	1730	1660	1510	1330	1140	920	600					
RDW EC 315	1650	55	3460	3330	3190	3030	2840	2440	1730	80							
RDD EC 315	1700	55	3450	3320	3190	3060	2910	2540	2000	910							
RDW EC 355	1700	59	5370	5190	5030	4870	4690	4280	3850	3260	2260						
RDD EC 355	1750	60	5310	5160	5000	4820	4650	4300	3870	3350	2610	280					
RDW EC 400	1500	60	6710	6520	6310	6100	5850	5350	4730	3980	2470						
RDD EC 400	1500	60	6420	6250	6080	5870	5660	5180	4600	3800	2360						
RDW EC 450	1300	60	8020	7760	7480	7180	6870	6260	5490	4390	840						
RDD EC 450 A	1425	63	8740	8520	8280	8030	7770	7240	6570	5800	4780	2300					
RDD EC 450 B	1800	69	10730	10540	10360	10160	9970	9560	9120	8690	8230	7680	7100	5380			
RDD EC 500 A	1400	65	12680	12370	12070	11770	11470	10750	10010	9160	8130	6820	4350				
RDD EC 500 B	1550	68	13550	13280	13000	12720	12420	11820	11220	10540	9740	8920	7960	3940			
RDD EC 560	1100	63	14020	13660	13280	12880	12460	11490	10450	9010	6900	380					
RDD EC 630	940	67	17680	17240	16750	16180	15590	14380	12860	10560	5580						

	Speed	Sound press. inlet side	Flow rate \dot{V} m ³ /h depending on static pressure = N / m^2 = freely available pressure														
	min^{-1}	L_{PA} dB(A)	(Δp_{fa}) in Pa														
		at 4 m dist.	0	50	100	150	200	300	400	500	600	700	800	1000			
Type VD EC																	
VDW EC 180	3330	54	670	640	610	570	540	460	370	210							
VDW EC 200	2670	55	1150	1070	1000	920	850	680	500	320	0						
VDW EC 225 A	2500	53	1260	1200	1120	1050	960	780	580	350	150						
VDW EC 225 B	3015	58	1430	1380	1320	1270	1200	1080	930	730	380						
VDW EC 250	2740	59	1820	1770	1720	1670	1600	1450	1280	1080	860	530					
VDW EC 315	1650	55	3440	3310	3170	3020	2860	2400	1630	180							
VDD EC 315	1700	55	3420	3290	3170	3040	2880	2480	1900	720							
VDW EC 355	1700	58	5070	4920	4780	4630	4470	4090	3570	2940	1870						
VDD EC 355	1750	59	5020	4890	4750	4610	4460	4120	3700	3100	2200	790					
VDW EC 400	1500	60	6180	6010	5820	5620	5400	4880	4230	3380	1630						
VDD EC 400	1500	59	6040	5870	5680	5450	5220	4770	4130	3300	1590						
VDW EC 450	1300	59	7350	7110	6870	6630	6330	5580	4640	3090	570						
VDD EC 450 A	1425	62	7990	7780	7560	7340	7090	6490	5810	4840	3360	1030					
VDD EC 450 B	1800	68	9940	9780	9620	9450	9270	8850	8420	7950	7390	6720	5850	3400			
VDD EC 500 A	1400	65	11100	10860	10620	10370	10100	9490	8760	7900	6730	5070	2620				
VDD EC 500 B	1550	68	11890	11690	11490	11270	11020	10480	9960	9310	8530	7630	6390	2100			
VDD EC 560	1100	62	12380	12050	11730	11380	10990	10050	9000	7390	4560	410					
VDD EC 630	940	67	15910	15500	15070	14570	14000	12710	11070	8370	2510						

Roof fans RD and VD

Selection table



By combining the parameters of static pressure increase Δp_{ra} , speed min^{-1} and inlet side air noise as sound pressure at

4 m (free field conditions), the following table facilitates the selection of AC roof fans.

Type RD	Speed	Sound press. inlet side	Flow rate V m ³ /h depending on static pressure = N / m ² = freely available pressure																
	min ⁻¹	L _{PA} dB(A)	(Δp_{ra}) in Pa																
		at 4 m dist.	0	50	100	150	200	250	300	400	500	600	800	1000	1200				
RDW 180/2	2295	41	550	490	440	360	290	200	120										
RDW 200/2	2430	48	1060	990	930	840	770	670	580	310									
RDW 200/4	1375	36	550	430	290														
RDW 225/2	2635	52	1310	1250	1200	1130	1060	990	930	760	520	90							
RDW 225/4	1340	36	650	550	410	30													
RDW 250/4	1340	38	920	800	630	440													
RDW 315/4	1385	46	2900	2720	2550	2330	2090	1830	1380										
RDD 315/4	1385	46	2890	2700	2510	2280	2060	1760	1290										
RDW 355/4	1400	46	4450	4260	4030	3790	3560	3280	2890	1870									
RDD 355/4	1350	46	4470	4230	4000	3700	3410	3120	2740	1650									
RDW 400/4	1405	51	6150	5920	5690	5450	5180	4910	4640	3970	2910	650							
RDD 400/4	1375	50	5950	5690	5430	5130	4850	4580	4230	3340	2050	310							
RDD 400/6	905	41	4030	3600	3180	2650	1910	420											
RDW 450/4	1385	54	8630	8340	8060	7770	7500	7200	6880	6220	5360	4240							
RDD 450/4	1400	54	8630	8380	8120	7840	7550	7270	6990	6280	5540	4400							
RDD 450/6	905	45	5830	5430	4910	4410	3780	2910	1530										
RDD 500/4	1340	56	12060	11710	11360	11000	10660	10310	9920	9140	8150	6980	3810						
RDD 500/6	885	47	8300	7750	7200	6670	5970	4990	3930	870									
RDD 560/4	1380	61	15660	15360	15040	14690	14320	13940	13570	12780	11960	11040	8810	5350	1220				
RDD 560/6	920	52	9820	9390	8960	8520	8100	7650	7130	5860	270								
RDD 630/6	930	59	15770	15200	14520	13870	13280	12580	11990	10460	8520	830							
RDD 710/6	968	63	26070	25460	24830	24150	23460	22790	22100	20390	18330	15660	6860						
Type VD																			
VDW 180/2	2315	40	540	500	430	360	290	200	110										
VDW 200/2	2430	48	1000	940	870	790	700	610	500	240									
VDW 200/4	1375	32	530	420	250														
VDW 225/2	2635	51	1290	1240	1170	1100	1030	950	880	680	410	70							
VDW 225/4	1340	37	640	540	370	30													
VDW 250/4	1340	38	900	780	610	380													
VDW 315/4	1385	46	2850	2670	2480	2290	2050	1720	1200	150									
VDD 315/4	1385	45	2870	2680	2500	2270	2020	1660	1130										
VDW 355/4	1400	46	4290	4100	3880	3660	3390	3090	2710	1690	230								
VDD 355/4	1350	46	4280	4050	3830	3600	3300	2990	2550	1470	120								
VDW 400/4	1405	51	5820	5610	5370	5110	4850	4600	4290	3480	2300	760							
VDD 400/4	1375	49	5590	5340	5100	4830	4530	4190	3820	2940	1600	390							
VDD 400/6	905	41	3760	3440	2970	2380	1590	590											
VDW 450/4	1385	53	7740	7520	7290	7030	6760	6450	6110	5390	4360	3000							
VDD 450/4	1400	53	7870	7640	7400	7140	6890	6630	6280	5560	4400	3170							
VDD 450/6	905	44	5210	4860	4390	3840	3150	2200	1100										
VDD 500/4	1340	56	10550	10280	10000	9690	9380	9080	8740	7940	7040	5880	2780						
VDD 500/6	885	47	7240	6760	6290	5710	5090	4310	3220	760									
VDD 560/4	1380	62	14060	13760	13450	13100	12720	12370	12050	11270	10440	9530	7400	4730	1480				
VDD 560/6	920	52	9240	8760	8350	7950	7500	7010	6450	4860	970								
VDD 630/6	930	58	14430	13780	13240	12670	12020	11390	10780	9110	6440	1100							
VDD 710/6	968	62	23760	23210	22630	21980	21260	20470	19700	17940	15800	13000	5000						

By combining the parameters of static pressure increase Δp_{ra} , speed min^{-1} and inlet side air noise as sound pressure at

4 m (free field conditions), the following table facilitates the selection of Ex and T120 roof fans.

	Speed	Sound press. inlet side	Flow rate $V \text{ m}^3/\text{h}$ depending on static pressure = N / m^2 = freely available pressure															
	min^{-1}	$L_{PA} \text{ dB(A)}$	(Δp_{ra}) in Pa															
		at 4 m dist.	0	50	100	150	200	250	300	400	500	600	700	800	900			
Type RD Ex																		
RDD 200/4 Ex	1465	41	600	510	380	60												
RDD 225/4 Ex	1445	43	850	760	620	400	0											
RDD 250/4 Ex	1400	46	1350	1230	1070	850	500											
RDD 315/4 Ex	1390	52	2890	2740	2590	2380	2180	1880	1450									
RDD 355/4 Ex	1345	58	4350	4120	3890	3660	3430	3130	2750	1600								
RDD 400/4 Ex	1395	63	6030	5860	5670	5440	5220	4980	4700	3970	2860	630						
RDD 400/6 Ex	930	52	3840	3500	3170	2760	2330	200										
RDD 450/4 Ex	1405	65	8580	8360	8120	7880	7620	7370	7120	6520	5780	4840	2710					
RDD 450/6 Ex	870	55	5640	5140	4650	4150	3560	2670	890									
RDD 500/4 Ex	1420	69	10310	9920	9560	9230	8920	8620	8320	7720	7060	6250	5170	1090				
RDD 500/6 Ex	840	58	6540	5850	5290	4580	3950	3300	690									
RDD 560/6 Ex	865	62	9420	8820	8330	7830	7320	6690	6080	3470								
RDD 630/6 Ex	905	68	16480	15930	15400	14850	14260	13600	12840	11110	8670	4340						
Type VD Ex			0	50	100	150	200	250	300	400	500	600	700	800	900			
VDD 200/4 Ex	1465	39	580	480	360	90												
VDD 225/4 Ex	1450	41	810	700	600	340												
VDD 250/4 Ex	1400	45	1280	1150	980	740	400											
VDD 315/4 Ex	1390	51	2760	2620	2470	2280	2030	1740	1310	70								
VDD 355/4 Ex	1350	57	4310	4120	3910	3630	3400	3060	2720	1590	230							
VDD 400/4 Ex	1375	62	5640	5460	5260	5050	4840	4580	4280	3560	2380	750						
VDD 400/6 Ex	930	52	3620	3300	2960	2480	1910	380										
VDD 450/4 Ex	1405	65	7920	7720	7500	7240	6980	6720	6390	5670	4720	3460	1870	240				
VDD 450/6 Ex	875	54	5170	4810	4350	3810	2990	1900	820									
VDD 500/4 Ex	1405	67	9360	9090	8810	8500	8190	7880	7580	6900	6170	5330	4130	990	0			
VDD 500/6 Ex	840	56	5850	5330	4830	4200	3530	2610	1230									
VDD 560/6 Ex	860	60	8460	7920	7480	7040	6580	5950	5210	1780								
VDD 630/6 Ex	910	67	14690	14220	13700	13140	12610	11920	11140	9280	6180	2670	180					

	Speed	Sound press. inlet side	Flow rate $V \text{ m}^3/\text{h}$ depending on static pressure = N / m^2 = freely available pressure															
	min^{-1}	$L_{PA} \text{ dB(A)}$	(Δp_{ra}) in Pa															
		at 4 m dist.	0	50	100	150	200	250	300	400	500	600	800	1000	1200			
Type VD T120																		
VDD 315/4 T120	1450	53	3362	3215	3053	2871	2664	2419	2116	887								
VDD 355/4 T120	1400	55	4540	4385	4217	4035	3834	3610	3352	2657								
VDD 400/4 T120	1400	54	6747	6557	6352	6129	5884	5614	5310	4568	3528	1698						
VDD 400/6 T120	967	46	4531	4232	3887	3475	2947	2155										
VDD 450/4 T120	1355	60	9479	9292	9093	8877	8643	8387	8103	7423	6501	5098						
VDD 450/6 T120	940	53	6398	6105	5762	5348	4824	4111	3038									
VDD 500/4 T120	1465	61	14001	13762	13514	13256	12987	12704	12406	11748	10971	9994	6202					
VDD 500/6 T120	945	52	9405	9038	8621	8131	7527	6719	5461	796								
VDD 560/4 T120	1480	63	16172	15942	15697	15435	15154	14853	14530	13809	12985	12061	9961	7462	2671			
VDD 560/6 T120	965	52	12200	11821	11403	10937	10408	9792	9049	6780	1699							
VDD 630/6 T120	985	63	19467	19039	18588	18110	17598	17043	16435	14976	12873	8159						
VDD 710/6 T120	985	62	24470	23974	23442	22870	22251	21580	20848	19169	17125	14600	6879					

Helios roof fans – versatile all-rounders.

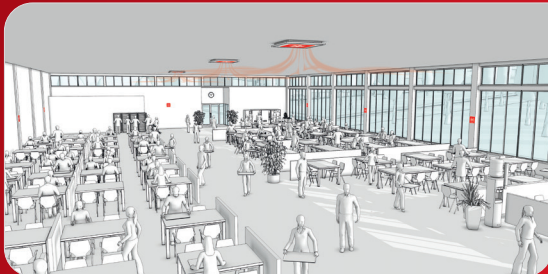

Cafeterias and recreation rooms

Series VD:

The vertical discharge series VD is the perfect partner for various applications in residential, commercial and public buildings. Especially in highly frequented areas, VD demonstrates its advantages and it can be ideally integrated in a comprehensive Helios ventilation system.

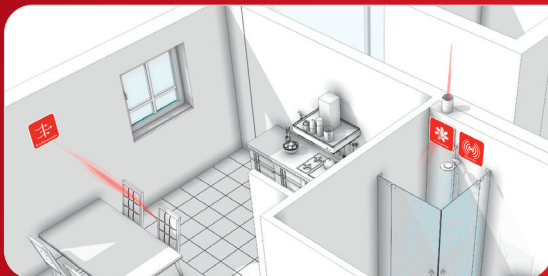

Apartment buildings

Series RD:

The roof fans in series RD discharge horizontally and they are also characterised by extremely flexible applications. Ideal for residential buildings, workplaces or public buildings.

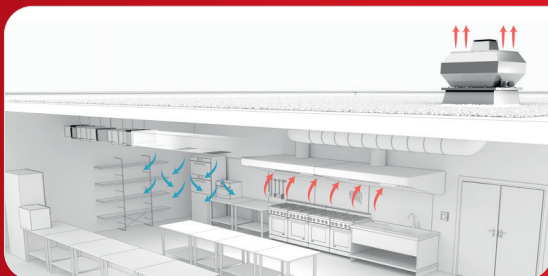

Commercial kitchens and production halls

Series VD T120:

Specialising in increased temperatures, the series VD T120 is predestined for areas with high levels of waste heat and for air flow temperatures of up to 120 °C. The exhaust air is extracted directly at its source, safely and hygienically due to the motor located outside of the air flow.

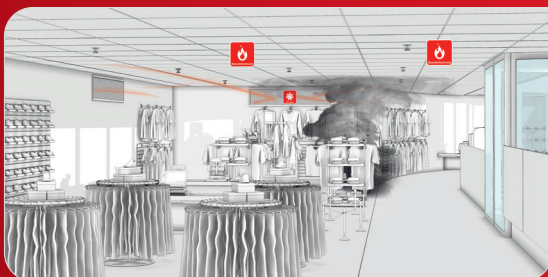

Shopping centres

Series B VD F400/F600:

Developed to withstand the most extreme conditions, the series B VD F400/F600 are invaluable lifesavers in case of fire. Thanks to their dual functionality, they can be used for everyday ventilation, e.g. in assembly areas and sales outlets, in addition to smoke extraction.



Fuel depots

Series RD / VD Ex:

Whether it is fuel depots, battery production or other potentially explosive atmospheres: The RD / VD Ex roof fans are reliable solutions thanks to the explosion protection – even in highly sensitive fuel depots.

Centrifugal roof fan RD, horizontal outlet.

Favourable price/performance ratio. Horizontal outlet roof fan with efficiency-optimised aluminium casing and newly developed high-performance centrifugal impeller.

EC roof fans DV, diagonal outlet.

With energy-saving EC drive technology for the lowest operating costs. Extremely weather-resistant in plastic design. Optionally available in Pro version with integrated pressure control for volume flow stabilisation (no Figure).

Centrifugal roof fans VD, vertical outlet.

Favourable price/performance ratio. Vertical outlet roof fan with efficiency-optimised aluminium casing or casing made of galvanised steel sheet and newly developed high-performance centrifugal impeller.

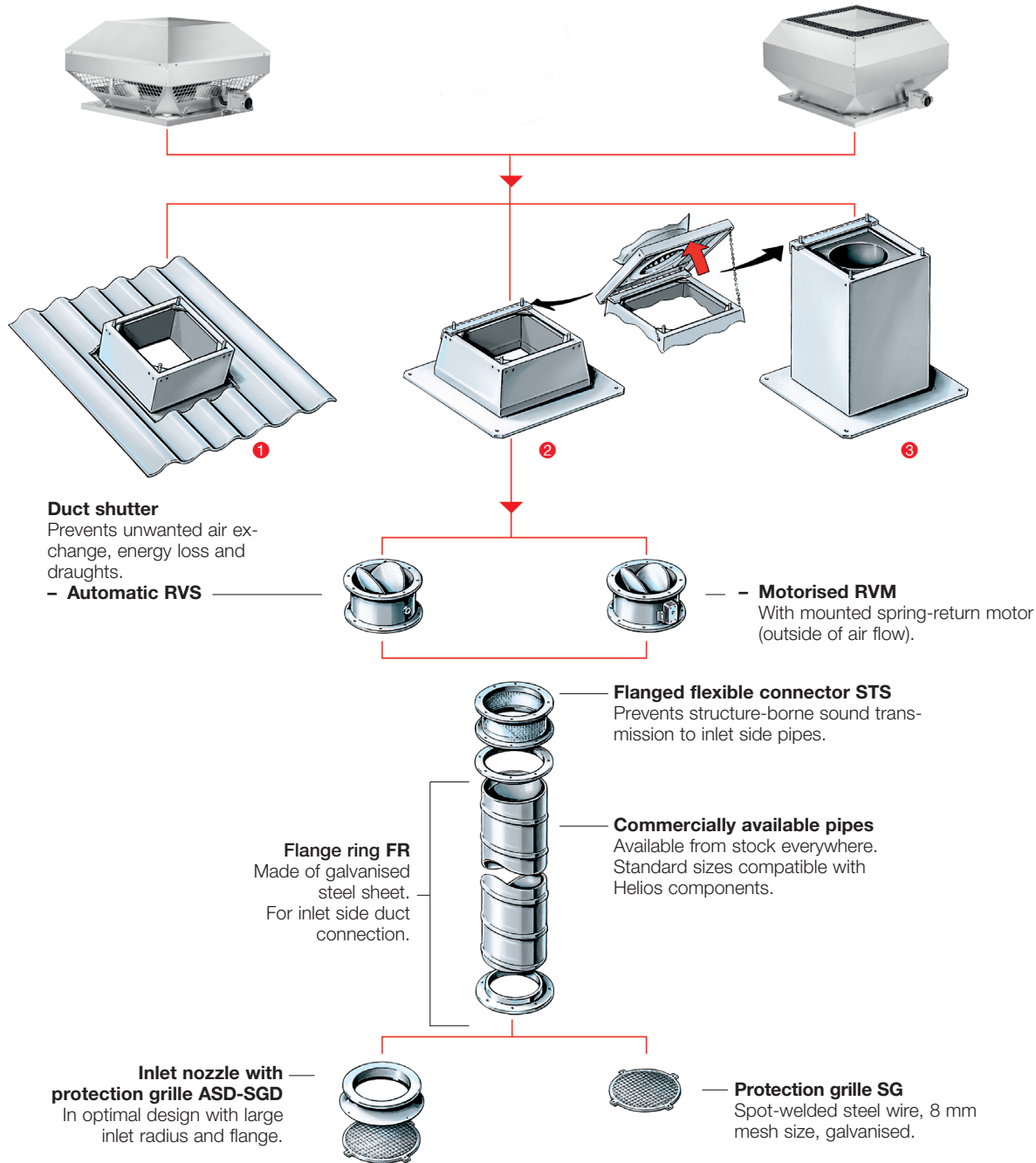

Duct shutter

Prevents unwanted air exchange, energy loss and draughts.

– Automatic RVS

– Motorised RVM

With mounted spring-return motor (outside of air flow).

Flanged flexible connector STS

Prevents structure-borne sound transmission to inlet side pipes.

Commercially available pipes

Available from stock everywhere. Standard sizes compatible with Helios components.

Flange ring FR
Made of galvanised steel sheet.
For inlet side duct connection.

Inlet nozzle with protection grille ASD-SGD

In optimal design with large inlet radius and flange.

Protection grille SG

Spot-welded steel wire, 8 mm mesh size, galvanised.

1 Corrugated roof base WDS

For the installation of roof fans and ventilation hoods on corrugated roofs. Weather-resistant and non-corrosive made of glass fibre reinforced polyester.

Pitched roof base SDS

For the installation of roof fans/ventilation hoods on pitched or trapezoidal roofs. Sound and heat insulated lining on the inside.

2 Flat roof base FDS

For the cost-effective and efficient installation of roof fans and ventilation hoods on flat roofs. In corrosion-resistant GFK version or made of galvanised steel sheet. NS 180 to 450 mm with hinged mechanism for easy inspection and cleaning.

3 Base silencer SSD

For inlet side noise reduction. All metal parts made of galvanised steel sheet. Incl. fixing screws, rubber profile and seal between the base and base plate. NS 180 to 450 mm with hinged mechanism and foam core with free cross-section. Allows access to the duct/shaft system.



Impeller
 High-performance centrifugal impeller with backward curved blades made of plastic (T120 and explosion-proof version made of aluminium). Dynamically balanced according to DIN ISO 21940-11 – quality grade 6.3.

Drive
 Speed-controllable external rotor motor in closed design (IP54) (explosion-proof version in IP44). Flange motor with self-ventilation (T120 version) in IP54. Ball bearing mounted with moisture protection. Maintenance-free and radio interference-free.

Motor protection
 Through built-in thermal contacts or built-in PTC thermistors, which must be connected to a motor protection circuit breaker. Assignment see type table.

Electrical connection
 No dismantling of casing, to external isolator switch (explosion-proof version to terminal box) in protection category IP65.

Protection grille
 On the outlet side as standard according to DIN EN ISO 13857.

Power control

All 1~ types have continuously variable speed control in the range from 0 – 100 % through electronic speed controllers or five-step control units. All 3~ types have continuously variable speed control in the range 0 – 100 % with a frequency inverter with integrated, all-pole effective sine filter (except for explosion-proof version) or five-step control units. Assignment see type table.

Delivery
 Units are ready-for-connection, fully pre-assembled in the shipping box.

Noise
 The total level and range are specified above the performance diagram for:

- Inlet side sound power
 - Outlet side sound power.
- The horizontally case-radiated noise as sound pressure at 4 m (free field conditions) is also specified in the type table. Hood silencer see Accessories.

References	Page
Planning information	14 ff.
Technical description	500 f.
Selection table	502 f.
Accessories, details	522 f.
Speed controllers, controllers and switches	599 ff.

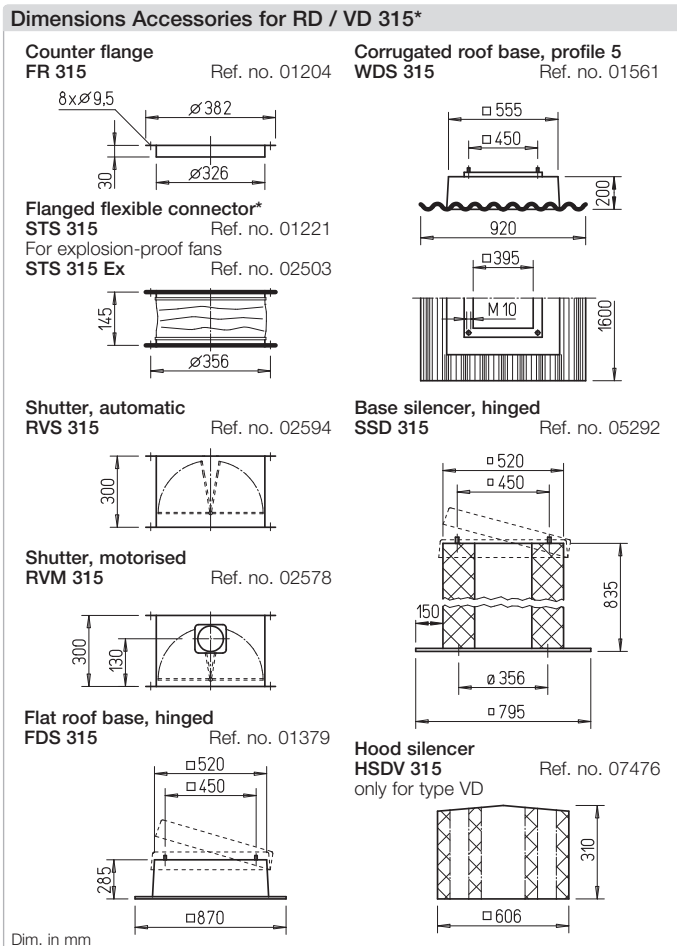
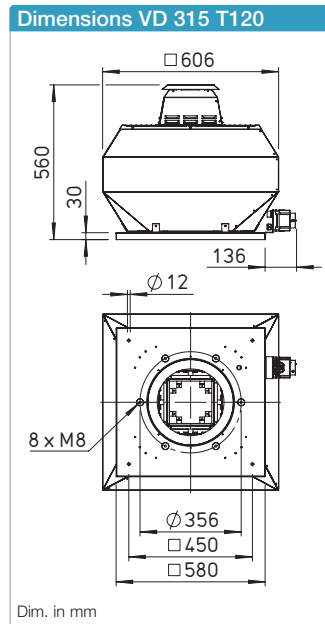
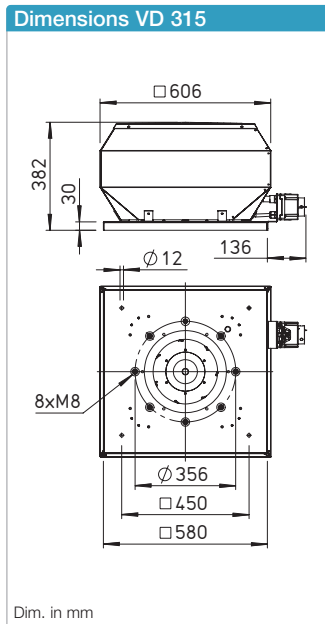
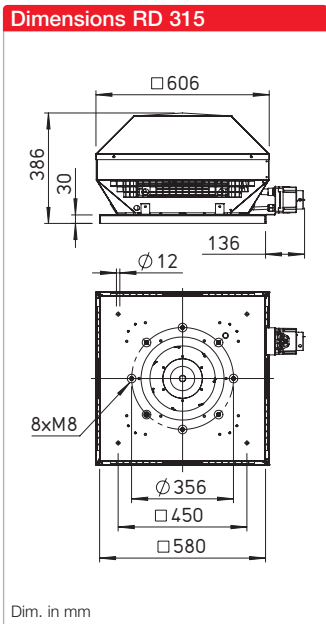

Description RD
 Horizontal outlet roof fan with efficiency-optimised aluminium casing and newly developed high-performance centrifugal impeller.

Description VD
 Vertical outlet roof fan with efficiency-optimised aluminium casing and newly developed high-performance centrifugal impeller.

Description VD T120
 Designed for the delivery of process air up to +120 °C. Enclosed motor located outside of the air flow. Compliant with VDI 2052.

Description of all series

Casing
 Casing made of sea water-resistant aluminium with integrated tamper protection. Motor support plate and base plate with inlet nozzle made of galvanised steel (explosion-proof version inlet nozzle made of aluminium). Base plate with threaded screws for attachment of inlet-side accessories (hole pattern according to DIN 24155).

* Accessories VD T120 see installation accessories p. 523 f. Other accessories upon request.

Performance curves RDW 315/4

Frequency	Hz	Tot.	125	250	500	1k	2k	4k	8k	
L _{WA} Inlet side		dB(A)	66	54	58	60	58	59	58	47
L _{WA} Outlet side		dB(A)	68	55	62	63	62	58	50	46

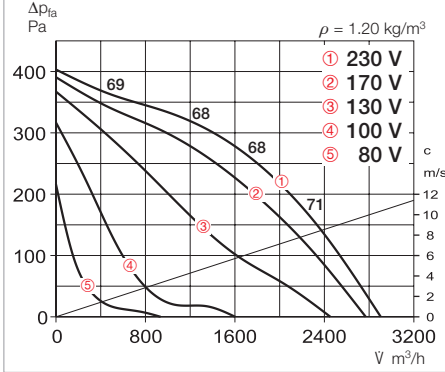

Performance curves RDD 315/4

Frequency	Hz	Tot.	125	250	500	1k	2k	4k	8k	
L _{WA} Inlet side		dB(A)	66	53	57	59	57	58	57	46
L _{WA} Outlet side		dB(A)	68	55	61	62	61	57	49	46

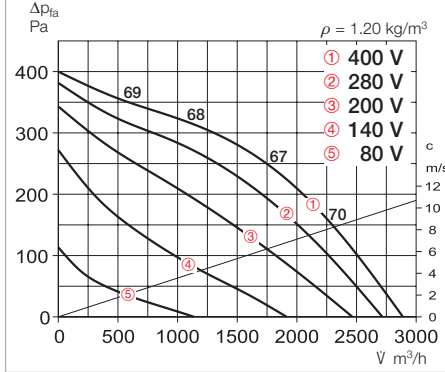

Type	Ref. no.	Speed	Flow rate Free blowing	Noise sound pressure	Power consump.	Current consump.		Wiring diagram	Max. air flow temp.		Weight net	Motor protection circuit breaker		Speed controller 5-step	
						at rated voltage	with control		at rated voltage	with control		Type	Ref. no.	Type	Ref. no.
Single phase alternating current, 1~, 230 V, 50 Hz, Capacitor motor, protection category IP54															
RDW 315/4	07287	1385	2900	51	300	1.47	2.0	1128	60	60	16.0	MW	01579	MWS 3 ²⁾	01948
Three phase current, 3~, 400 V, 50 Hz, Squirrel-cage rotor, Protection category IP54															
RDD 315/4	07288	1385	2890	51	290	0.67	0.67	1129	60	60	19.0	MD	05849	RDS 1 ²⁾	01314
Ex Explosion-proof, II 2G Ex h IIB + H ₂ T3 Gb, Motor Ex e, Three phase current, 3~, 400 V, 50 Hz, Protection category IP44															
RDD 315/4 Ex ¹⁾	07303	1390	2890	51.5	340	0.73	0.73	1157	40	40	19.0	MSA	01289	TSD 1.5	01501

1) Performance diagram at www.HeliosSelect.de.

2) Includes motor protection circuit breaker.

Performance curves VDW 315/4

Frequency	Hz	Tot.	125	250	500	1k	2k	4k	8k	
L _{WA} Inlet side		dB(A)	66	53	57	59	57	58	57	46
L _{WA} Outlet side		dB(A)	69	58	61	62	63	58	53	45

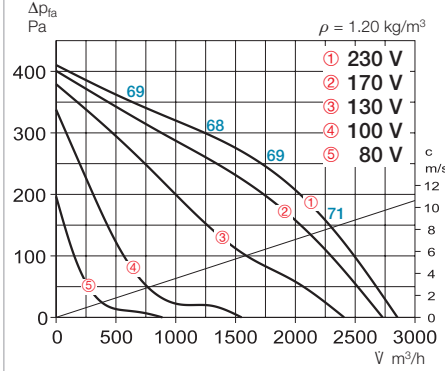

Performance curves VDD 315/4

Frequency	Hz	Tot.	125	250	500	1k	2k	4k	8k	
L _{WA} Inlet side		dB(A)	65	53	57	59	57	58	57	46
L _{WA} Outlet side		dB(A)	68	58	61	62	63	58	52	42

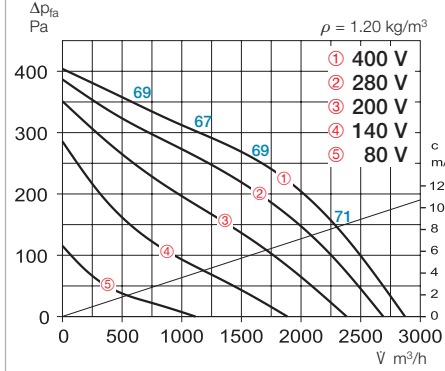

Type	Ref. no.	Speed	Flow rate Free blowing	Noise sound pressure	Power consump.	Current consump.		Wiring diagram	Max. air flow temp.		Weight net	Motor protection circuit breaker		Speed controller 5-step	
						at rated voltage	with control		at rated voltage	with control		Type	Ref. no.	Type	Ref. no.
Single phase alternating current, 1~, 230 V, 50 Hz, Capacitor motor, protection category IP54															
VDW 315/4	07279	1385	2860	52	300	1.47	2.0	1128	60	50	21.0	MW	01579	MWS 3 ²⁾	01948
Three phase current, 3~, 400 V, 50 Hz, Squirrel-cage rotor, Protection category IP54															
VDD 315/4	07282	1385	2880	51	290	0.67	0.67	1129	60	60	20.0	MD	05849	RDS 1 ²⁾	01314
Ex Explosion-proof, II 2G Ex h IIB + H ₂ T3 Gb, Motor Ex e, Three phase current, 3~, 400 V, 50 Hz, Protection category IP44															
VDD 315/4 Ex ¹⁾	07293	1390	2770	50.5	330	0.71	1.71	1157	40	40	19.5	MSA	01289	TSD 1.5	01501
T120 Three phase current, 3~, 400 V, 50 Hz, Squirrel-cage rotor, Protection category IP54															
VDD 315/4 T120 ¹⁾	07315	1450	3372	55	395	0.89	1.1	1264	120	100	25.0	MD	05849	RDS 2 ²⁾	01315

1) Performance diagram at www.HeliosSelect.de.

2) Includes motor protection circuit breaker.



Impeller
 High-performance centrifugal impeller with backward curved blades made of plastic (T120 and explosion-proof version made of aluminium). Dynamically balanced according to DIN ISO 21940-11 – quality grade 6.3.

Drive
 Speed-controllable external rotor motor in closed design (IP54) (explosion-proof version in IP44). Flange motor with self-ventilation (T120 version) in IP54. Ball bearing mounted with moisture protection. Maintenance-free and radio interference-free.

Motor protection
 Through built-in thermal contacts or built-in PTC thermistors, which must be connected to a motor protection circuit breaker. Assignment see type table.

Electrical connection
 No dismantling of casing, to external isolator switch (explosion-proof version to terminal box) in protection category IP65.

Protection grille
 On the outlet side as standard according to DIN EN ISO 13857.

Power control

All 1~ types have continuously variable speed control in the range from 0 – 100 % through electronic speed controllers or five-step control units. All 3~ types have continuously variable speed control in the range 0 – 100 % with a frequency inverter with integrated, all-pole effective sine filter (except for explosion-proof version) or five-step control units. Assignment see type table.

Delivery
 Units are ready-for-connection, fully pre-assembled in the shipping box.

Noise
 The total level and range are specified above the performance diagram for:

- Inlet side sound power
 - Outlet side sound power.
- The horizontally case-radiated noise as sound pressure at 4 m (free field conditions) is also specified in the type table. Hood silencer see Accessories.

References	Page
Planning information	14 ff.
Technical description	500 f.
Selection table	502 f.
Accessories, details	522 f.
Speed controllers, controllers and switches	599 ff.

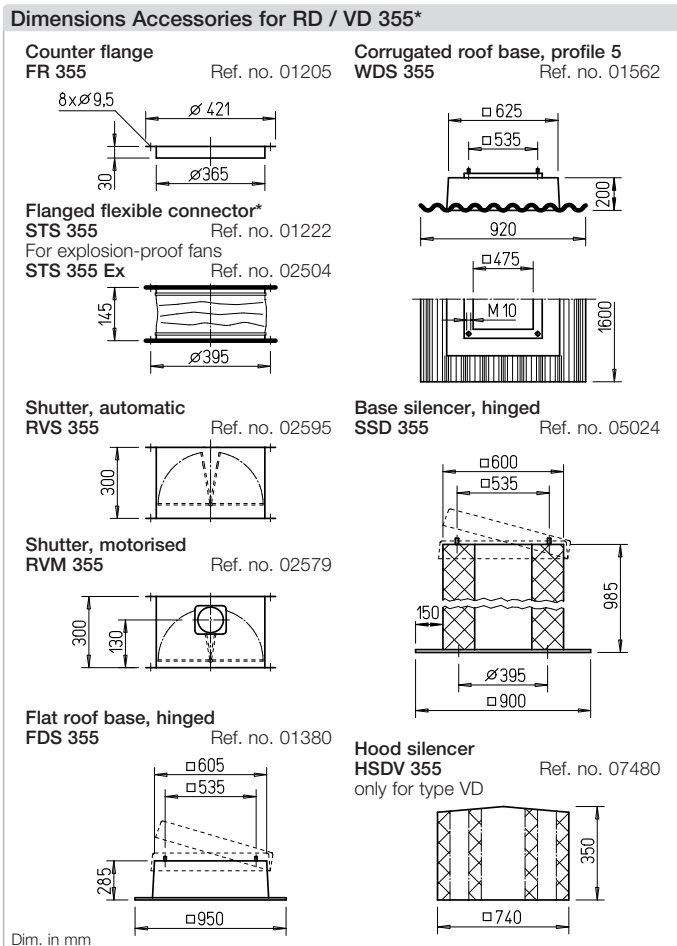
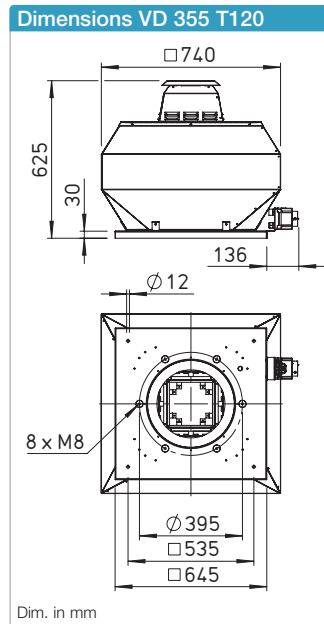
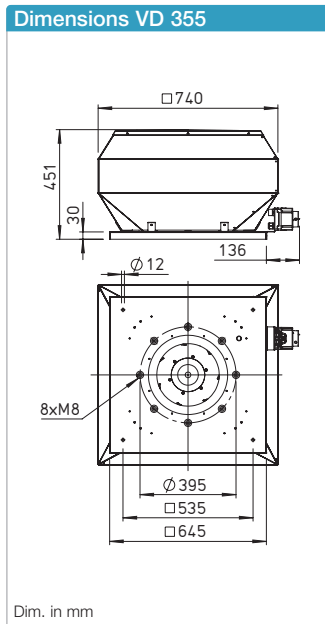
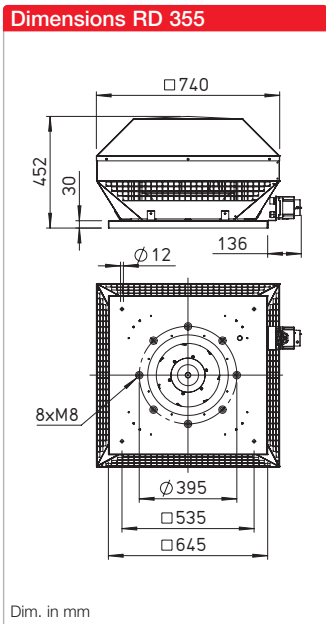

Description RD
 Horizontal outlet roof fan with efficiency-optimised aluminium casing and newly developed high-performance centrifugal impeller.

Description VD
 Vertical outlet roof fan with efficiency-optimised aluminium casing and newly developed high-performance centrifugal impeller.

Description VD T120
 Designed for the delivery of process air up to +120 °C. Enclosed motor located outside of the air flow. Compliant with VDI 2052.

Description of all series

Casing
 Casing made of sea water-resistant aluminium with integrated tamper protection. Motor support plate and base plate with inlet nozzle made of galvanised steel (explosion-proof version inlet nozzle made of aluminium). Base plate with threaded screws for attachment of inlet-side accessories (hole pattern according to DIN 24155).

* Accessories VD T120 see installation accessories p. 523 f. Other accessories upon request.

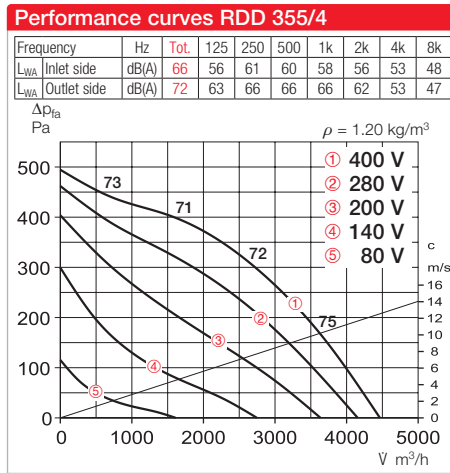
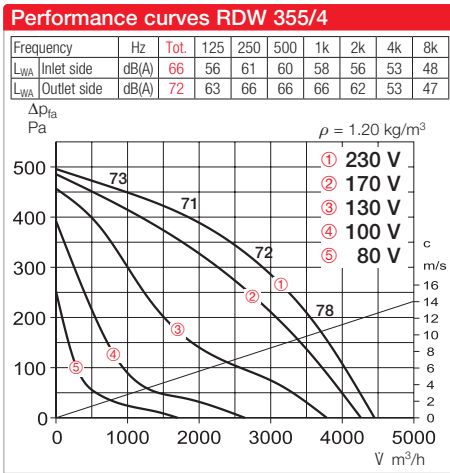

Type	Ref. no.	Speed	Flow rate Free blowing	Noise sound pressure	Power consump.	Current consump.		Wiring diagram	Max. air flow temp.		Weight net	Motor protection circuit breaker		Speed controller 5-step	
						at rated voltage	with control		at rated voltage	with control		Type	Ref. no.	Type	Ref. no.
Single phase alternating current, 1~, 230 V, 50 Hz, Capacitor motor, protection category IP54															
RDW 355/4	07323	1400	4480	55	520	2.55	3.4	1128	70	55	27.0	MW	01579	MWS 5 ²⁾	01949
Three phase current, 3~, 400 V, 50 Hz, Squirrel-cage rotor, Protection category IP54															
RDD 355/4	07326	1350	4470	55	460	0.92	1.0	1129	60	60	25.0	MD	05849	RDS 2 ²⁾	01315
Ex Explosion-proof, II 2G Ex h IIB + H ₂ T3 Gb, Motor Ex e, Three phase current, 3~, 400 V, 50 Hz, Protection category IP44															
RDD 355/4 Ex ¹⁾	07329	1345	4345	58	540	1.21	1.21	1157	40	40	25.0	MSA	01289	TSD 3	01502

1) Performance diagram at www.HeliosSelect.de.

2) Includes motor protection circuit breaker.

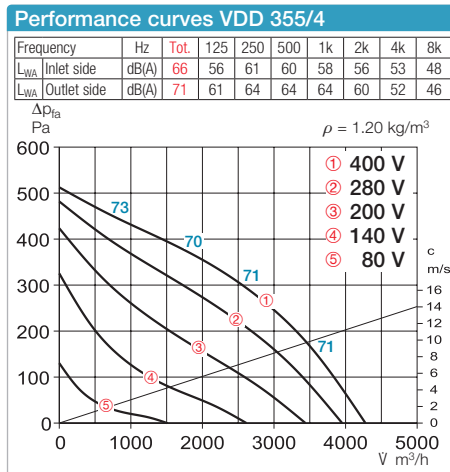
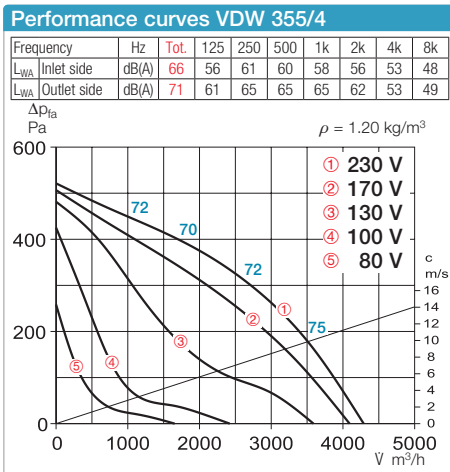

Type	Ref. no.	Speed	Flow rate Free blowing	Noise sound pressure	Power consump.	Current consump.		Wiring diagram	Max. air flow temp.		Weight net	Motor protection circuit breaker		Speed controller 5-step	
						at rated voltage	with control		at rated voltage	with control		Type	Ref. no.	Type	Ref. no.
Single phase alternating current, 1~, 230 V, 50 Hz, Capacitor motor, protection category IP54															
VDW 355/4	07317	1400	4300	54	520	2.55	3.4	1128	60	55	27.0	MW	01579	MWS 5 ²⁾	01949
Three phase current, 3~, 400 V, 50 Hz, Squirrel-cage rotor, Protection category IP54															
VDD 355/4	07318	1350	4290	54	460	0.92	1.0	1129	60	60	25.5	MD	05849	RDS 2 ²⁾	01315
Ex Explosion-proof, II 2G Ex h IIB + H ₂ T3 Gb, Motor Ex e, Three phase current, 3~, 400 V, 50 Hz, Protection category IP44															
VDD 355/4 Ex ¹⁾	07327	1350	4320	57	520	1.17	1.17	1157	40	40	25.5	MSA	01289	TSD 3	01502
T120 Three phase current, 3~, 400 V, 50 Hz, Squirrel-cage rotor, Protection category IP54															
VDD 355/4 T120 ¹⁾	07336	1400	4597	58	584	1.3	1.4	1264	120	100	34.0	MD	05849	RDS 4 ²⁾	01316

1) Performance diagram at www.HeliosSelect.de.

2) Includes motor protection circuit breaker.



Impeller
 High-performance centrifugal impeller with backward curved blades made of plastic (T120 and explosion-proof version made of aluminium). Dynamically balanced according to DIN ISO 21940-11 – quality grade 6.3.

Drive
 Speed-controllable external rotor motor in closed design (IP54) (explosion-proof version in IP44). Flange motor with self-ventilation (T120 version) in IP54. Ball bearing mounted with moisture protection. Maintenance-free and radio interference-free.

Motor protection
 Through built-in thermal contacts or built-in PTC thermistors, which must be connected to a motor protection circuit breaker. Assignment see type table.

Electrical connection
 No dismantling of casing, to external isolator switch (explosion-proof version to terminal box) in protection category IP65.

Protection grille
 On the outlet side as standard according to DIN EN ISO 13857.

Power control

All 1~ types have continuously variable speed control in the range from 0 – 100 % through electronic speed controllers or five-step control units. All 3~ types have continuously variable speed control in the range 0 – 100 % with a frequency inverter with integrated, all-pole effective sine filter (except for explosion-proof version) or five-step control units. Assignment see type table.

Delivery
 Units are ready-for-connection, fully pre-assembled in the shipping box.

Noise
 The total level and range are specified above the performance diagram for:

- Inlet side sound power
 - Outlet side sound power.
- The horizontally case-radiated noise as sound pressure at 4 m (free field conditions) is also specified in the type table. Hood silencer see Accessories.

References	Page
Planning information	14 ff.
Technical description	500 f.
Selection table	502 f.
Accessories, details	522 f.
Speed controllers, controllers and switches	599 ff.

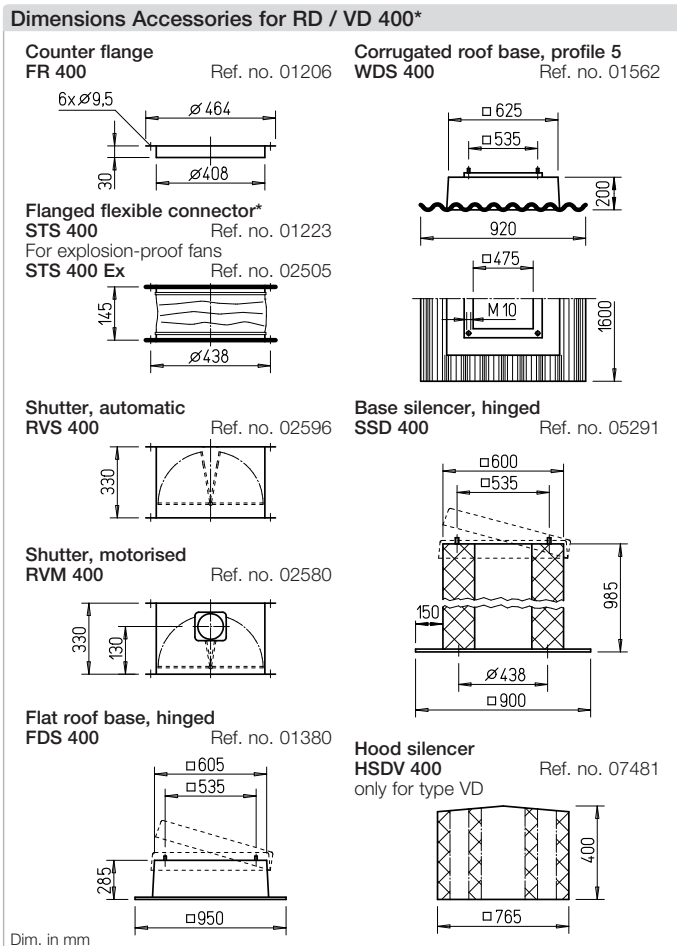
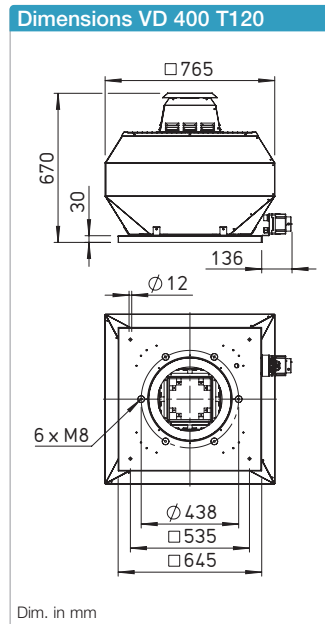
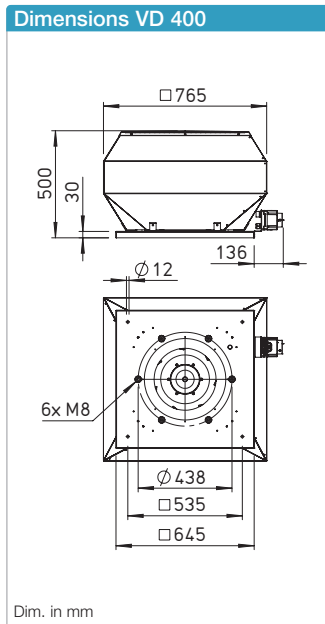
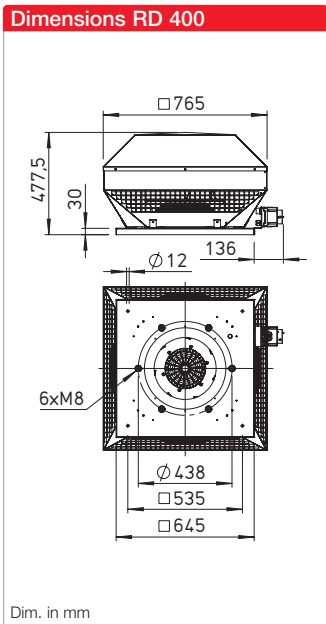

Description RD
 Horizontal outlet roof fan with efficiency-optimised aluminium casing and newly developed high-performance centrifugal impeller.

Description VD
 Vertical outlet roof fan with efficiency-optimised aluminium casing and newly developed high-performance centrifugal impeller.

Description VD T120
 Designed for the delivery of process air up to +120 °C. Enclosed motor located outside of the air flow. Compliant with VDI 2052.

Description of all series

Casing
 Casing made of sea water-resistant aluminium with integrated tamper protection. Motor support plate and base plate with inlet nozzle made of galvanised steel (explosion-proof version inlet nozzle made of aluminium). Base plate with threaded screws for attachment of inlet-side accessories (hole pattern according to DIN 24155).

* Accessories VD T120 see installation accessories p. 523 f. Other accessories upon request.

Performance curves RDW 400/4

Frequency	Hz	Tot.	125	250	500	1k	2k	4k	8k
L _{WA} Inlet side	dB(A)	71	61	65	66	63	62	56	52
L _{WA} Outlet side	dB(A)	76	55	62	62	60	60	50	39

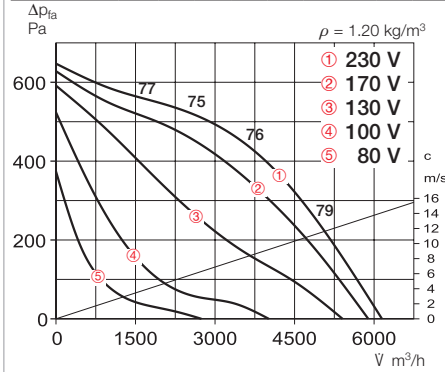

Performance curves RDD 400/4

Frequency	Hz	Tot.	125	250	500	1k	2k	4k	8k
L _{WA} Inlet side	dB(A)	70	60	64	65	62	61	55	51
L _{WA} Outlet side	dB(A)	75	55	62	62	62	59	50	39

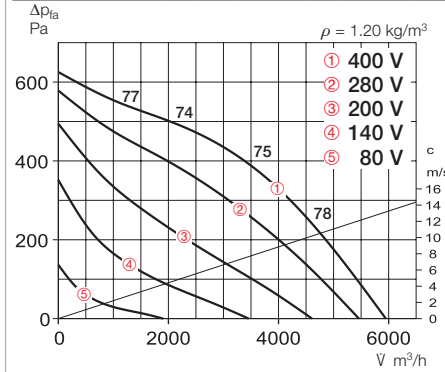

Performance curves RDD 400/6

Frequency	Hz	Tot.	125	250	500	1k	2k	4k	8k
L _{WA} Inlet side	dB(A)	61	51	55	56	53	52	46	42
L _{WA} Outlet side	dB(A)	66	55	62	62	62	59	50	39

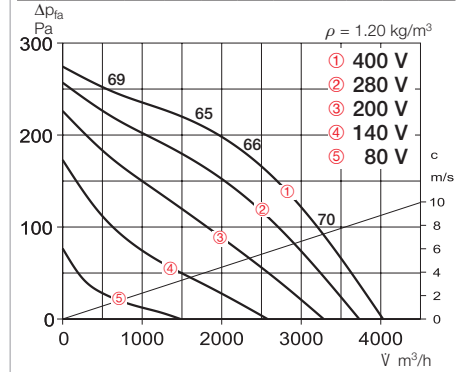

Type	Ref. no.	Speed	Flow rate Free blowing	Noise sound pressure	Power consump.	Current consump.		Wiring diagram	Max. air flow temp.		Weight net	Motor protection circuit breaker		Speed controller 5-step	
						at rated voltage	with control		at rated voltage	with control		Type	Ref. no.	Type	Ref. no.
Single phase alternating current, 1~, 230 V, 50 Hz, Capacitor motor, protection category IP54															
RDW 400/4	07350	1405	6150	59	875	4.3	6.0	1128	60	40	33.0	MW	01579	MWS 7.5 ²⁾	01950
Three phase current, 3~, 400 V, 50 Hz, Squirrel-cage rotor, Protection category IP54															
RDD 400/6	07352	905	4030	49	260	0.6	0.6	1129	60	60	27.0	MD	05849	RDS 1 ²⁾	01314
RDD 400/4	07351	1375	5970	58	765	1.55	1.6	1129	60	55	27.0	MD	05849	RDS 2 ²⁾	01315
Explosion-proof, II 2G Ex h IIB + H ₂ T3 Gb, Motor Ex e, Three phase current, 3~, 400 V, 50 Hz, Protection category IP44															
RDD 400/6 Ex ¹⁾	07363	930	3840	52	330	0.86	0.86	1157	40	40	24.0	MSA	01289	TSD 1.5	01501
RDD 400/4 Ex ¹⁾	07358	1395	6030	62.5	950	1.9	2.1	1157	40	40	33.0	MSA	01289	TSD 3.0	01502

1) Performance diagram at www.HeliosSelect.de.

2) Includes motor protection circuit breaker.

Performance curves VDW 400/4

Frequency	Hz	Tot.	125	250	500	1k	2k	4k	8k
L _{WA} Inlet side	dB(A)	71	61	65	66	63	62	56	52
L _{WA} Outlet side	dB(A)	76	63	71	70	70	66	60	54

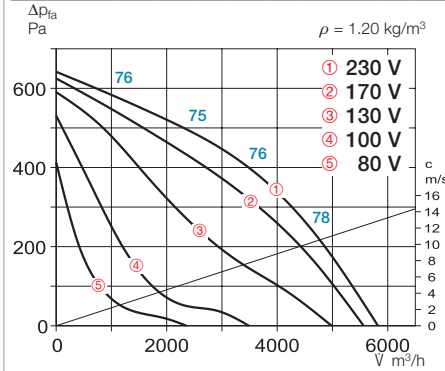

Performance curves VDD 400/4

Frequency	Hz	Tot.	125	250	500	1k	2k	4k	8k
L _{WA} Inlet side	dB(A)	69	59	63	64	61	60	54	50
L _{WA} Outlet side	dB(A)	74	61	69	68	68	64	58	52

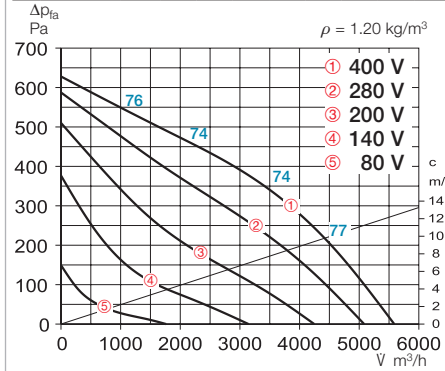

Performance curves VDD 400/6

Frequency	Hz	Tot.	125	250	500	1k	2k	4k	8k
L _{WA} Inlet side	dB(A)	61	51	55	56	53	52	46	42
L _{WA} Outlet side	dB(A)	66	53	61	60	60	56	50	44

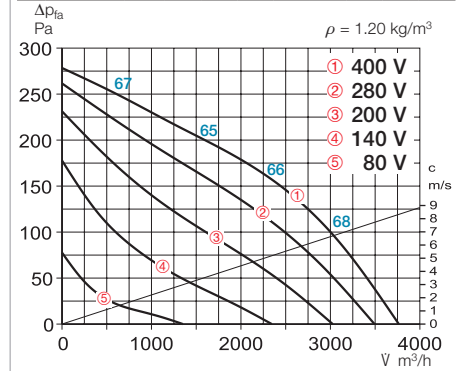

Type	Ref. no.	Speed	Flow rate Free blowing	Noise sound pressure	Power consump.	Current consump.		Wiring diagram	Max. air flow temp.		Weight net	Motor protection circuit breaker		Speed controller 5-step	
						at rated voltage	with control		at rated voltage	with control		Type	Ref. no.	Type	Ref. no.
Single phase alternating current, 1~, 230 V, 50 Hz, Capacitor motor, protection category IP54															
VDW 400/4	07338	1405	5830	59	875	4.3	6.0	1128	60	40	33.0	MW	01579	MWS 7.5 ²⁾	01950
Three phase current, 3~, 400 V, 50 Hz, Squirrel-cage rotor, Protection category IP54															
VDD 400/6	07343	905	3780	49	260	0.6	0.6	1129	60	60	28.0	MD	05849	RDS 1 ²⁾	01314
VDD 400/4	07342	1375	5590	57	765	1.55	1.6	1129	60	55	29.5	MD	05849	RDS 2 ²⁾	01315
Explosion-proof, II 2G Ex h IIB + H ₂ T3 Gb, Motor Ex e, Three phase current, 3~, 400 V, 50 Hz, Protection category IP44															
VDD 400/6 Ex ¹⁾	07359	930	3630	51.5	320	0.89	0.89	1157	40	40	25.0	MSA	01289	TSD 1.5	01501
VDD 400/4 Ex ¹⁾	07353	1375	5350	57	1000	2.1	2.2	1129	40	40	29.5	MSA	01289	TSD 3	01502
T120 Three phase current, 3~, 400 V, 50 Hz, Squirrel-cage rotor, Protection category IP54															
VDD 400/6 T120 ¹⁾	07366	967	4535	54	353	2.17	1.02	1264	120	100	36.0	MD	05849	TSD 1.5	01501
VDD 400/4 T120 ¹⁾	07370	1400	6824	62	1045	4.2	2.28	1264	120	100	36.0	MD	05849	TSD 5.5	01503

1) Performance diagram at www.HeliosSelect.de.

2) Includes motor protection circuit breaker.



Impeller
 High-performance centrifugal impeller with backward curved blades made of plastic (T120 and explosion-proof version made of aluminium). Dynamically balanced according to DIN ISO 21940-11 – quality grade 6.3.

Drive
 Speed-controllable external rotor motor in closed design (IP54) (explosion-proof version in IP44). Flange motor with self-ventilation (T120 version) in IP54. Ball bearing mounted with moisture protection. Maintenance-free and radio interference-free.

Motor protection
 Through built-in thermal contacts or built-in PTC thermistors, which must be connected to a motor protection circuit breaker. Assignment see type table.

Electrical connection
 No dismantling of casing, to external isolator switch (explosion-proof version to terminal box) in protection category IP65.

Protection grille
 On the outlet side as standard according to DIN EN ISO 13857.

Power control

All 1~ types have continuously variable speed control in the range from 0 – 100 % through electronic speed controllers or five-step control units. All 3~ types have continuously variable speed control in the range 0 – 100 % with a frequency inverter with integrated, all-pole effective sine filter (except for explosion-proof version) or five-step control units. Assignment see type table.

Delivery
 Units are ready-for-connection, fully pre-assembled in the shipping box. Easy positioning due to standard crane hook.

Noise
 The total level and range are specified above the performance diagram for:

- Inlet side sound power
- Outlet side sound power.

The horizontally case-radiated noise as sound pressure at 4 m (free field conditions) is also specified in the type table. Hood silencer see Accessories.

References	Page
Planning information	14 ff.
Technical description	500 f.
Selection table	502 f.
Accessories, details	522 f.
Speed controllers, controllers and switches	599 ff.

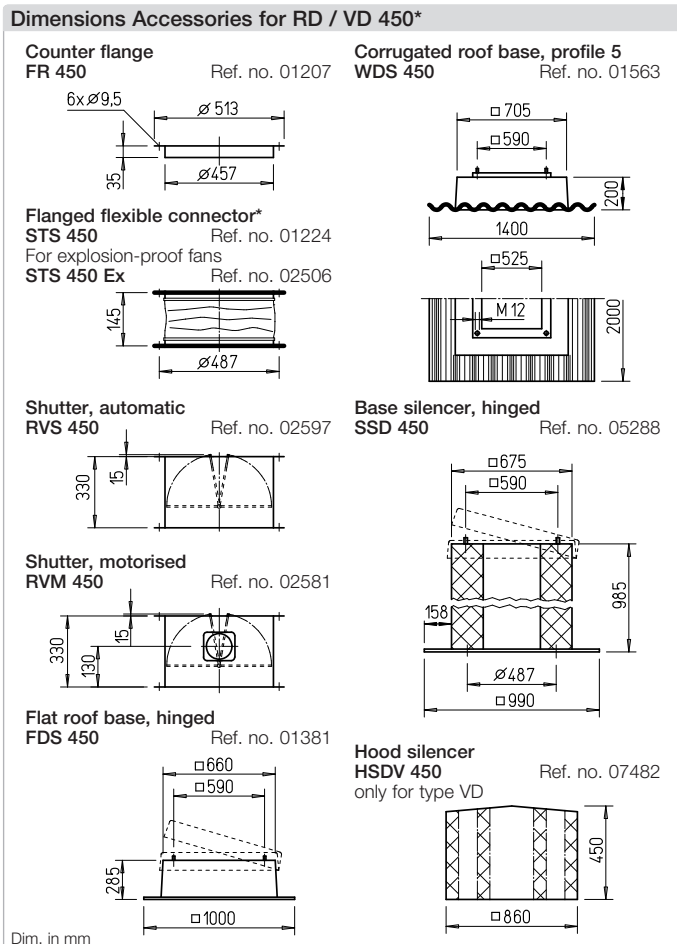
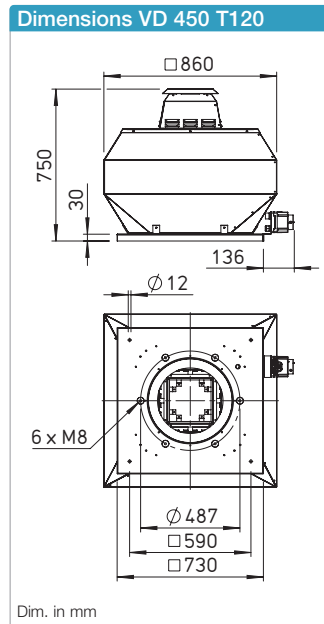
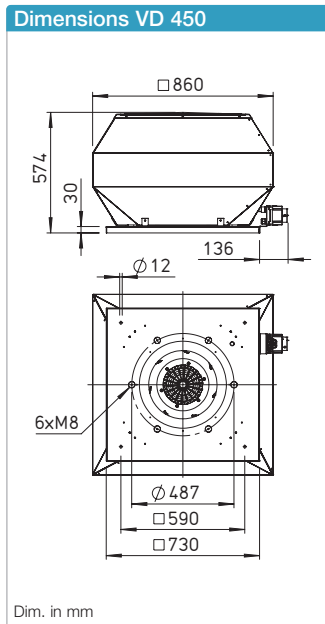
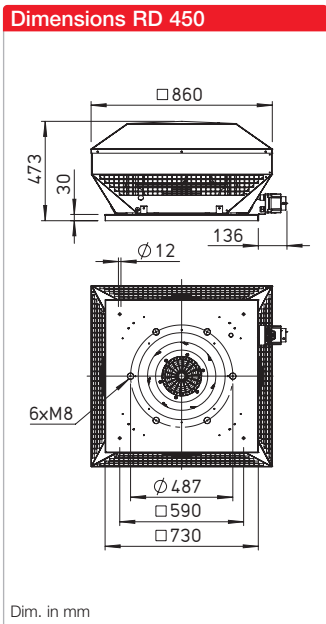

Description RD
 Horizontal outlet roof fan with efficiency-optimised aluminium casing and newly developed high-performance centrifugal impeller.

Description VD
 Vertical outlet roof fan with efficiency-optimised aluminium casing and newly developed high-performance centrifugal impeller.

Description VD T120
 Designed for the delivery of process air up to +120 °C. Enclosed motor located outside of the air flow. Compliant with VDI 2052.

Description of all series

Casing
 Casing made of sea water-resistant aluminium with integrated tamper protection. Motor support plate and base plate with inlet nozzle made of galvanised steel (explosion-proof version inlet nozzle made of aluminium). Base plate with threaded screws for attachment of inlet-side accessories (hole pattern according to DIN 24155).

* Accessories VD T120 see installation accessories p. 523 f. Other accessories upon request.

Performance curves RDW 450/4

Frequency	Hz	Tot.	125	250	500	1k	2k	4k	8k
L _{WA} Inlet side	dB(A)	74	63	68	68	67	66	61	55
L _{WA} Outlet side	dB(A)	79	69	70	70	74	69	62	55

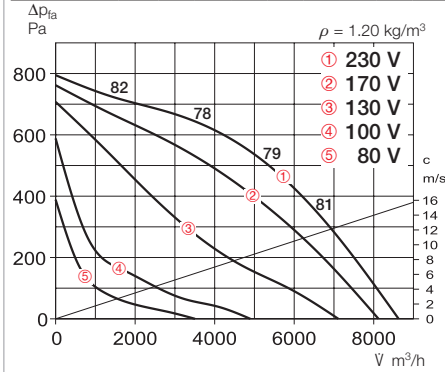

Performance curves RDD 450/4

Frequency	Hz	Tot.	125	250	500	1k	2k	4k	8k
L _{WA} Inlet side	dB(A)	74	63	68	68	67	66	61	55
L _{WA} Outlet side	dB(A)	79	69	70	70	74	69	62	55

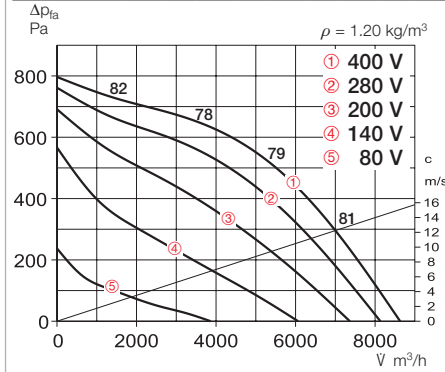

Performance curves RDD 450/6

Frequency	Hz	Tot.	125	250	500	1k	2k	4k	8k
L _{WA} Inlet side	dB(A)	65	54	59	59	58	57	52	46
L _{WA} Outlet side	dB(A)	70	60	61	61	65	60	53	46

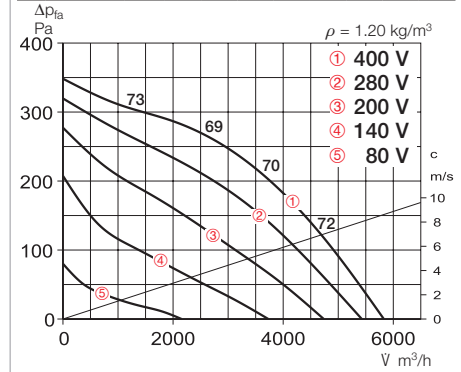

Type	Ref. no.	Speed	Flow rate Free blowing	Noise sound pressure	Power consump.	Current consump.		Wiring diagram	Max. air flow temp.		Weight net	Motor protection circuit breaker		Speed controller 5-step	
						at rated voltage	with control		at rated voltage	with control		Type	Ref. no.	Type	Ref. no.
Single phase alternating current, 1~, 230 V, 50 Hz, Capacitor motor, protection category IP54															
RDW 450/4	07377	1385	8650	62	1470	6.6	8.7	1128	60	40	46.0	MW	01579	MWS 10 ²⁾	01946
Three phase current, 3~, 400 V, 50 Hz, Squirrel-cage rotor, Protection category IP54															
RDD 450/6	07385	905	5850	53	425	1.1	1.1	1129	60	60	39.0	MD	05849	RDS 2 ²⁾	01315
RDD 450/4	07384	1400	8650	62	1350	2.9	2.9	1129	60	60	45.0	MD	05849	RDS 4 ²⁾	01316
Explosion-proof, II 2G Ex h IIB + H ₂ T3 Gb, Motor Ex e, Three phase current, 3~, 400 V, 50 Hz, Protection category IP44															
RDD 450/6 Ex ¹⁾	07391	870	5630	54.5	470	1.13	1.13	1129	60	60	39.0	MSA	01289	TSD 1.5	01501
RDD 450/4 Ex ¹⁾	07390	1405	8580	64.5	1620	3.3	3.66	1157	40	40	46.0	MSA	01289	TSD 5.5	01503

1) Performance diagram at www.HeliosSelect.de.

2) Includes motor protection circuit breaker.

Performance curves VDW 450/4

Frequency	Hz	Tot.	125	250	500	1k	2k	4k	8k
L _{WA} Inlet side	dB(A)	73	62	67	67	66	65	60	54
L _{WA} Outlet side	dB(A)	79	69	70	70	74	69	62	55

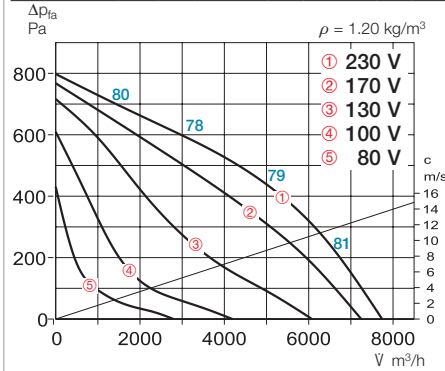

Performance curves VDD 450/4

Frequency	Hz	Tot.	125	250	500	1k	2k	4k	8k
L _{WA} Inlet side	dB(A)	73	62	67	67	66	65	60	54
L _{WA} Outlet side	dB(A)	79	70	71	71	75	70	63	56

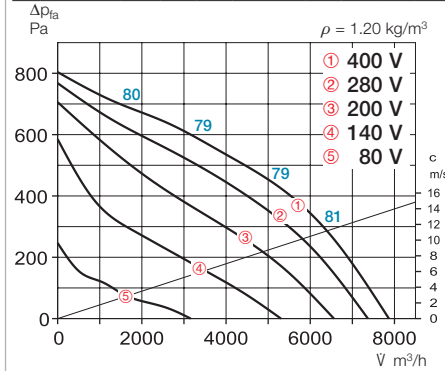

Performance curves VDD 450/6

Frequency	Hz	Tot.	125	250	500	1k	2k	4k	8k
L _{WA} Inlet side	dB(A)	64	53	58	58	57	56	51	45
L _{WA} Outlet side	dB(A)	70	60	61	61	65	60	53	46

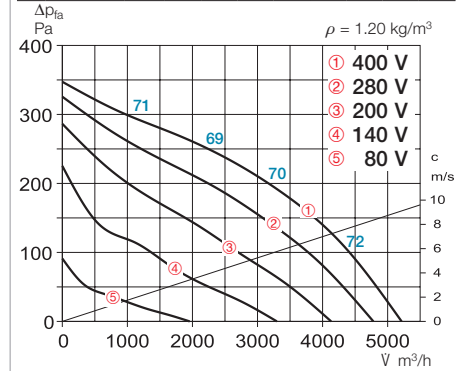

Type	Ref. no.	Speed	Flow rate Free blowing	Noise sound pressure	Power consump.	Current consump.		Wiring diagram	Max. air flow temp.		Weight net	Motor protection circuit breaker		Speed controller 5-step	
						at rated voltage	with control		at rated voltage	with control		Type	Ref. no.	Type	Ref. no.
Single phase alternating current, 1~, 230 V, 50 Hz, Capacitor motor, protection category IP54															
VDW 450/4	07372	1385	7750	62	1470	6.6	8.7	1128	60	40	47.0	MW	01579	MWS 10 ²⁾	01946
Three phase current, 3~, 400 V, 50 Hz, Squirrel-cage rotor, Protection category IP54															
VDD 450/6	07380	905	5200	53	425	1.06	1.06	1129	60	60	40.0	MD	05849	RDS 2 ²⁾	01315
VDD 450/4	07379	1400	7900	62	1350	2.9	2.9	1129	60	60	47.0	MD	05849	RDS 4 ²⁾	01316
Explosion-proof, II 2G Ex h IIB + H ₂ T3 Gb, Motor Ex e, Three phase current, 3~, 400 V, 50 Hz, Protection category IP44															
VDD 450/6 Ex ¹⁾	07387	875	5170	54	460	1.1	1.1	1157	40	40	40.0	MSA	01289	TSD 1.5	01501
VDD 450/4 Ex ¹⁾	07386	1405	7930	65	1570	3.3	3.66	1157	40	40	47.0	MSA	01289	TSD 5.5	01503
T120 Three phase current, 3~, 400 V, 50 Hz, Squirrel-cage rotor, Protection category IP54															
VDD 450/6 T120 ¹⁾	07399	940	6515	62	660	2.05	2.05	1264	90	—	54.0	MD	05849	RDS 4 ²⁾	01316
VDD 450/4 T120 ¹⁾	07398	1355	9792	69	1830	3.8	3.8	1264	80	—	60.0	MD	05849	RDS 7 ²⁾	01578

1) Performance diagram at www.HeliosSelect.de.

2) Includes motor protection circuit breaker.



Impeller
 High-performance centrifugal impeller with backward curved blades made of plastic (T120 and explosion-proof version made of aluminium). Dynamically balanced according to DIN ISO 21940-11 – quality grade 6.3.

Drive
 Speed-controllable external rotor motor in closed design (IP54) (explosion-proof version in IP44). Flange motor with self-ventilation (T120 version) in IP54/55. Ball bearing mounted with moisture protection. Maintenance-free and radio interference-free.

Motor protection
 Through built-in thermal contacts or built-in PTC thermistors, which must be connected to a motor protection circuit breaker. Assignment see type table.

Electrical connection
 No dismantling of casing, to external isolator switch (explosion-proof version to terminal box) in protection category IP65.

Protection grille
 On the outlet side as standard according to DIN EN ISO 13857.

Power control
 All types have continuously variable speed control in the range from 0 – 100 % with a frequency inverter with integrated, all-pole effective sine filter (except for explosion-proof version) or five-step control units (except for units with FU). Assignment see type table.

Delivery
 Units are ready-for-connection, fully pre-assembled in the shipping box. Easy positioning due to standard crane hook.

Noise
 The total level and range are specified above the performance diagram for:

- Inlet side sound power
- Outlet side sound power.

The horizontally case-radiated noise as sound pressure at 4 m (free field conditions) is also specified in the type table. Hood silencer see Accessories.

References	Page
Planning information	14 ff.
Technical description	500 f.
Selection table	502 f.
Accessories, details	522 f.
Speed controllers, controllers and switches	599 ff.

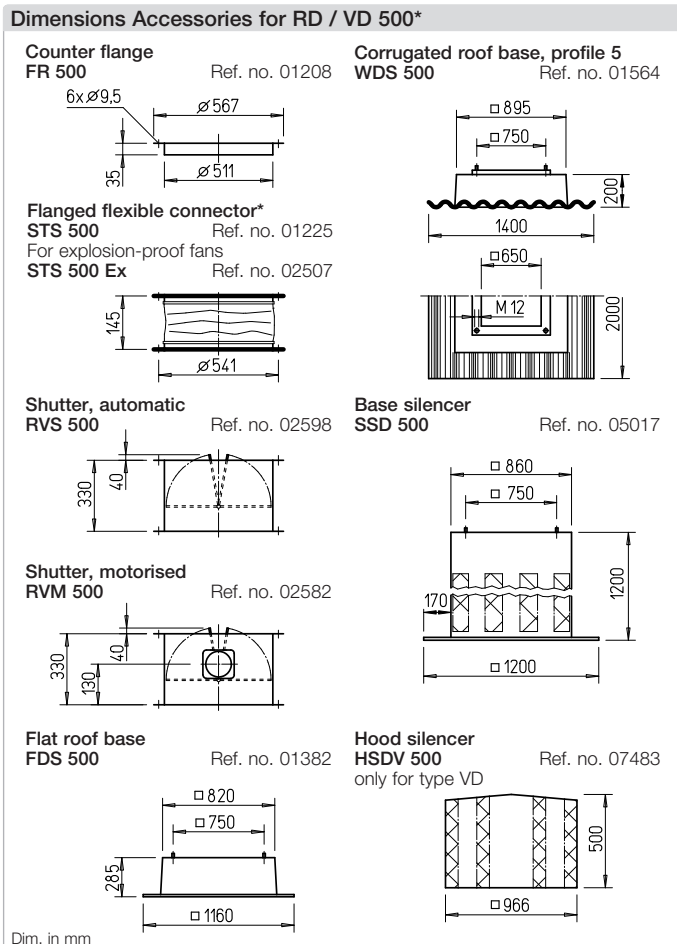
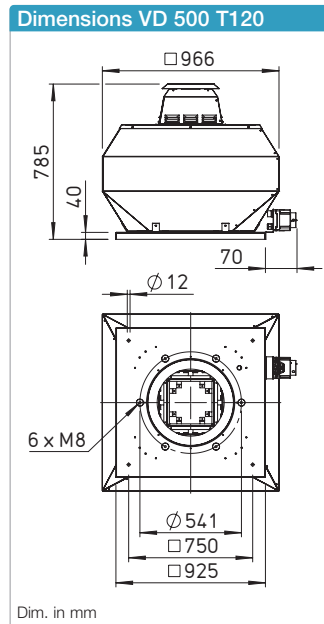
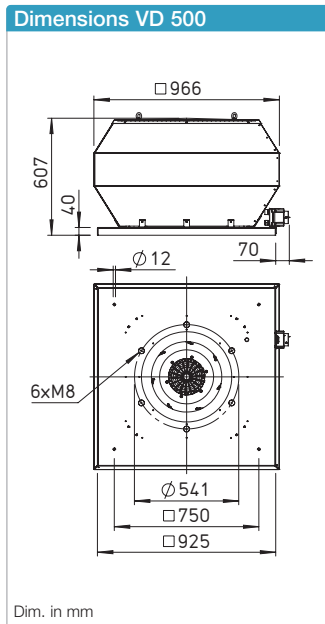
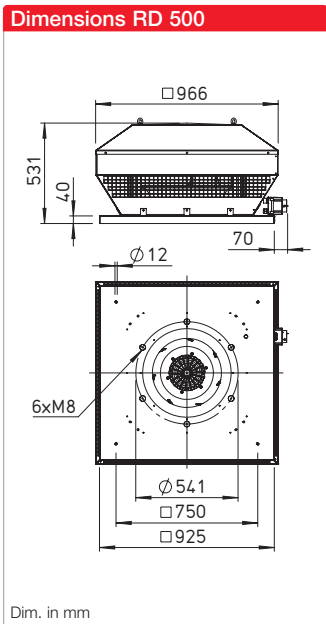

Description RD
 Horizontal outlet roof fan with efficiency-optimised aluminium casing and newly developed high-performance centrifugal impeller.

Description VD
 Vertical outlet roof fan with efficiency-optimised aluminium casing and newly developed high-performance centrifugal impeller.

Description VD T120
 Designed for the delivery of process air up to +120 °C. Enclosed motor located outside of the air flow. Compliant with VDI 2052.

Description of all series

Casing
 Casing made of sea water-resistant aluminium with integrated tamper protection. Motor support plate and base plate with inlet nozzle made of galvanised steel (explosion-proof version inlet nozzle made of aluminium). Base plate with threaded screws for attachment of inlet-side accessories (hole pattern according to DIN 24155).

* Accessories VD T120 see installation accessories p. 523 f. Other accessories upon request.

Performance curves RDD 500/4

Frequency	Hz	Tot.	125	250	500	1k	2k	4k	8k
L _{WA} Inlet side	dB(A)	76	67	71	69	69	66	62	58
L _{WA} Outlet side	dB(A)	81	72	74	75	76	70	65	58

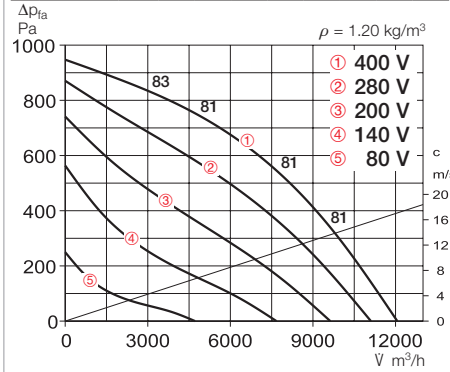

Performance curves RDD 500/6

Frequency	Hz	Tot.	125	250	500	1k	2k	4k	8k
L _{WA} Inlet side	dB(A)	67	58	62	60	60	57	53	49
L _{WA} Outlet side	dB(A)	72	63	65	66	67	61	56	49

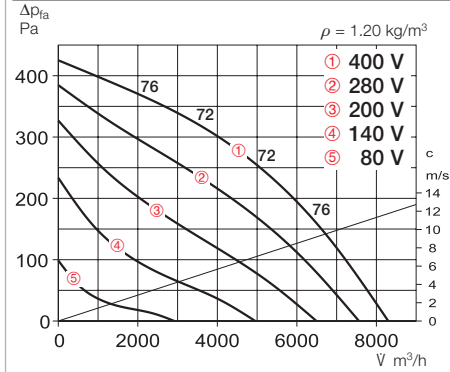

Type	Ref. no.	Speed	Flow rate Free blowing	Noise sound pressure	Power consump.	Current consump.		Wiring diagram	Max. air flow temp.		Weight net	Motor protection circuit breaker		Speed controller 5-step	
						at rated voltage	with control		at rated voltage	with control		Type	Ref. no.	Type	Ref. no.
Three phase current, 3~, 400 V, 50 Hz, Squirrel-cage rotor, Protection category IP54															
RDD 500/6	07410	885	8300	55	680	1.55	1.55	1129	50	50	55.0	MD	05849	RDS 2 ²⁾	01315
RDD 500/4	07409	1340	12100	64	2150	4.15	4.25	1129	55	50	58.0	MD	05849	RDS 7 ²⁾	01578
Ex Explosion-proof, II 2G Ex h IIB + H ₂ T3 Gb, Motor Ex e, Three phase current, 3~, 400 V, 50 Hz, Protection category IP44															
RDD 500/6 Ex ¹⁾	07414	840	6550	57.5	570	1.21	1.21	1157	40	40	51.0	MSA	01289	TSD 1.5	01501
RDD 500/4 Ex ¹⁾	07416	1420	13030	64	2250	4.5	5.8	—	40	40	58.0	MSA	01289	TSD 1.5	01501

1) Performance diagram at www.HeliosSelect.de.

2) Includes motor protection circuit breaker.

Performance curves VDD 500/4

Frequency	Hz	Tot.	125	250	500	1k	2k	4k	8k
L _{WA} Inlet side	dB(A)	76	67	71	69	69	66	62	58
L _{WA} Outlet side	dB(A)	82	71	75	76	76	74	69	61

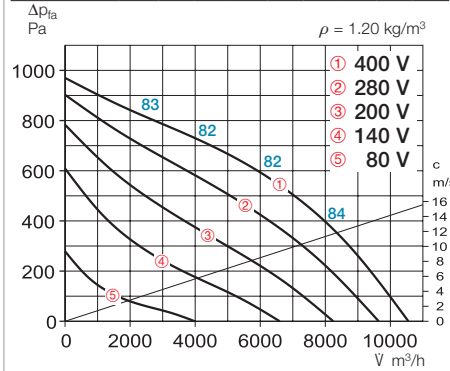

Performance curves VDD 500/6

Frequency	Hz	Tot.	125	250	500	1k	2k	4k	8k
L _{WA} Inlet side	dB(A)	67	58	62	60	60	57	53	49
L _{WA} Outlet side	dB(A)	73	62	66	67	67	65	60	52

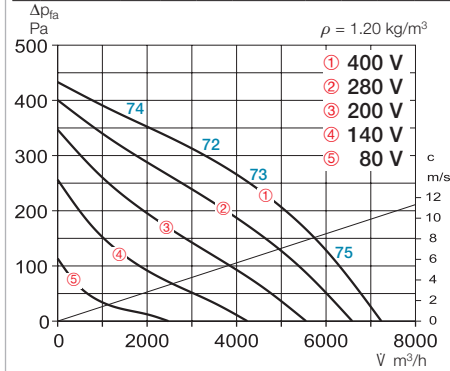

Type	Ref. no.	Speed	Flow rate Free blowing	Noise sound pressure	Power consump.	Current consump.		Wiring diagram	Max. air flow temp.		Weight net	Motor protection circuit breaker		Speed controller 5-step	
						at rated voltage	with control		at rated voltage	with control		Type	Ref. no.	Type	Ref. no.
Three phase current, 3~, 400 V, 50 Hz, Squirrel-cage rotor, Protection category IP54															
VDD 500/6	07402	885	7250	56	680	1.55	1.55	1129	50	50	56.0	MD	05849	RDS 2 ²⁾	01315
VDD 500/4	07401	1340	10550	65	2150	4.15	4.25	1129	55	50	65.0	MD	05849	RDS 7 ²⁾	01578
Ex Explosion-proof, II 2G Ex h IIB + H ₂ T3 Gb, Motor Ex e, Three phase current, 3~, 400 V, 50 Hz, Protection category IP44															
VDD 500/6 Ex ¹⁾	07412	840	5850	56	560	1.2	1.2	1157	40	40	53.0	MSA	01289	TSD 1.5	01501
VDD 500/4 Ex ¹⁾	07413	1405	9350	66.5	2250	4.3	5.1	1157	40	40	68.0	MSA	01289	TSD 7	01504
T120 Three phase current, 3~, 400 V, 50 Hz, Squirrel-cage rotor, Protection category IP54 or IP55*															
VDD 500/6 T120 ¹⁾	07419	945	9568	61	100	2.1	2.1	1264	100	—	62.0	MSA	01289	TSD 7	01504
VDD 500/4 T120 ¹⁾	07418	1465	14078	70	3060	5.8	5.8	1130	95	—	71.0	MSA	01289	—	—

1) Performance diagram at www.HeliosSelect.de.

2) Includes motor protection circuit breaker.



Impeller
 High-performance centrifugal impeller with backward curved blades made of aluminium. Dynamically balanced according to DIN ISO 21940-11 – quality grade 6.3.

Drive
 Speed-controllable external rotor motor in closed design (IP54) (explosion-proof version in IP44). Flange motor with self-ventilation (T120 version) in IP54/55. Ball bearing mounted with moisture-free and radio interference-free.

Motor protection
 Through built-in thermal contacts or built-in PTC thermistors, which must be connected to a motor protection circuit breaker. Assignment see type table.

Electrical connection
 No dismantling of casing, to external isolator switch (explosion-proof version to terminal box) in protection category IP65.

Protection grille
 On the outlet side as standard according to DIN EN ISO 13857.

Power control
 All types have continuously variable speed control in the range from 0 – 100 % with a frequency inverter with integrated, all-pole effective sine filter (except for explosion-proof version) or five-step control units (except for units with FU). Assignment see type table.

Delivery
 Units are ready-for-connection, fully pre-assembled in the shipping box. Easy positioning due to standard crane hook.

Noise
 The total level and range are specified above the performance diagram for:

- Inlet side sound power
 - Outlet side sound power.
- The horizontally case-radiated noise as sound pressure at 4 m (free field conditions) is also specified in the type table. Hood silencer see Accessories.

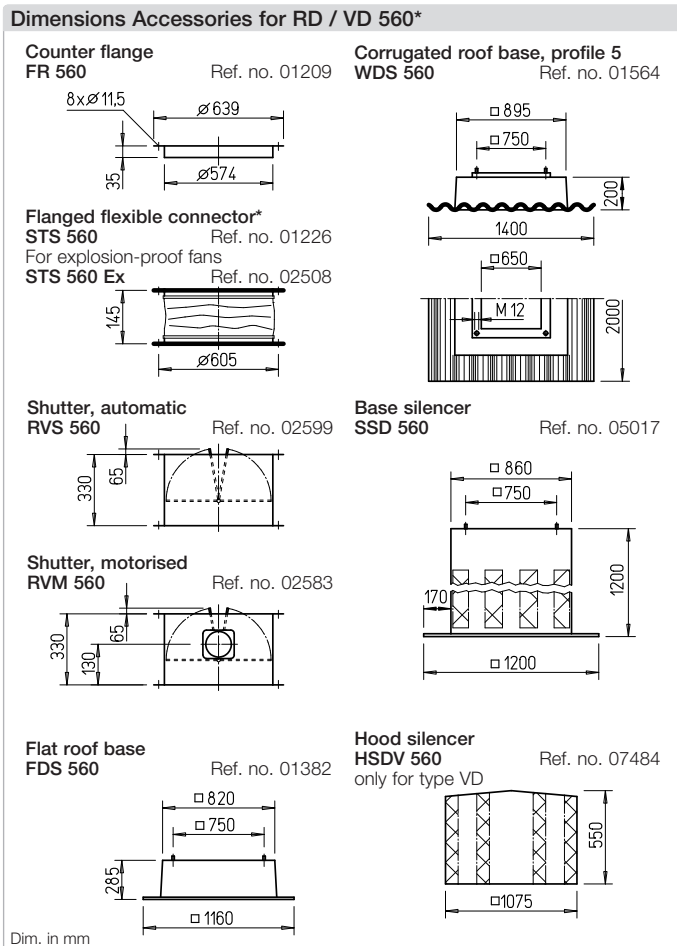
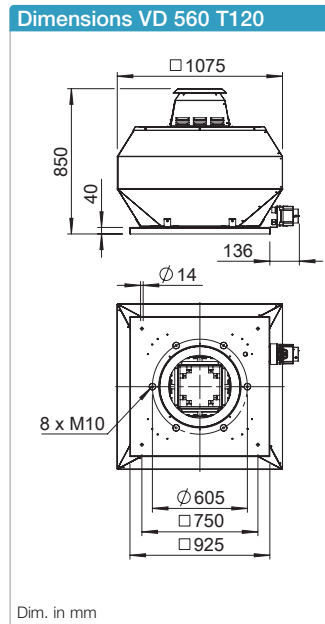
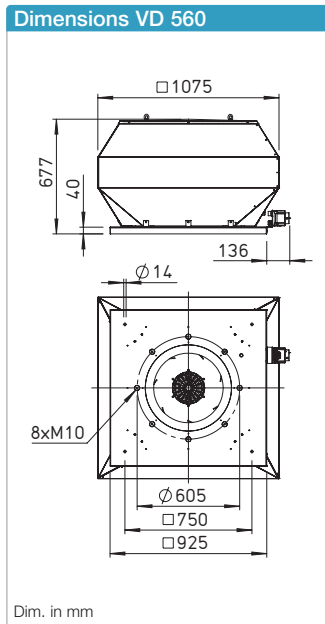
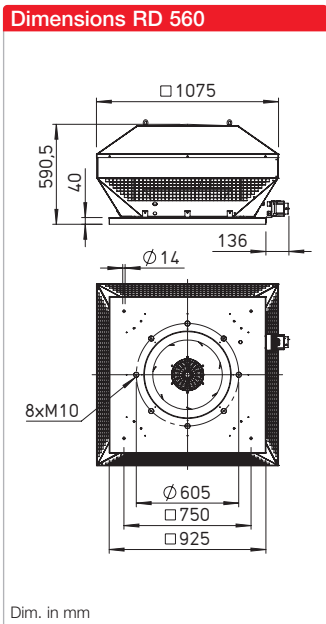

Description RD
 Horizontal outlet roof fan with efficiency-optimised aluminium casing and newly developed high-performance centrifugal impeller.

Description VD
 Vertical outlet roof fan with efficiency-optimised aluminium casing and newly developed high-performance centrifugal impeller.

Description VD T120
 Designed for the delivery of process air up to +120 °C. Enclosed motor located outside of the air flow. Compliant with VDI 2052.

Description of all series

Casing
 Casing made of sea water-resistant aluminium with integrated tamper protection. Motor support plate and base plate with inlet nozzle made of galvanised steel (explosion-proof version inlet nozzle made of aluminium). Base plate with threaded screws for attachment of inlet-side accessories (hole pattern according to DIN 24155).

References	Page
Planning information	14 ff.
Technical description	500 f.
Selection table	502 f.
Accessories, details	522 f.
Speed controllers, controllers and switches	599 ff.

* Accessories VD T120 see installation accessories p. 523 f. Other accessories upon request.

Performance curve RDD 560/4

Frequency	Hz	Tot.	125	250	500	1k	2k	4k	8k
L _{WA} Inlet side	dB(A)	81	70	72	73	74	73	69	62
L _{WA} Outlet side	dB(A)	86	74	77	79	80	77	70	61

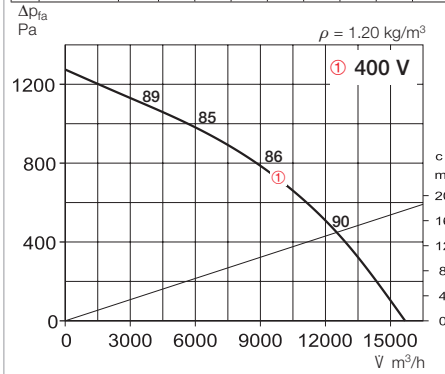

Performance curves RDD 560/6

Frequency	Hz	Tot.	125	250	500	1k	2k	4k	8k
L _{WA} Inlet side	dB(A)	72	62	64	65	66	65	61	54
L _{WA} Outlet side	dB(A)	77	66	69	71	72	69	62	53

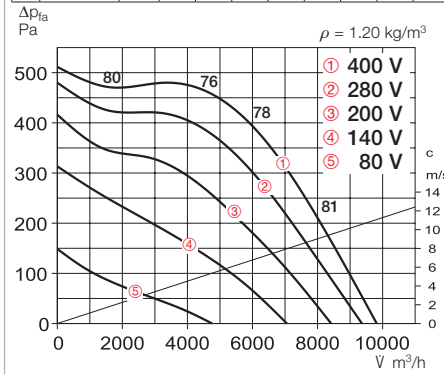

Type	Ref. no.	Speed	Flow rate Free blowing	Noise sound pressure	Power consump.	Current consump.		Wiring diagram	Max. air flow temp.		Weight net	Motor protection circuit breaker		Speed controller 5-step	
						at rated voltage	with control		at rated voltage	with control		Type	Ref. no.	Type	Ref. no.
Three phase current, 3~, 400 V, 50 Hz, Squirrel-cage rotor, Protection category IP54															
RDD 560/6	07429	920	9850	60	1180	3.2	3.2	1129	60	60	72.0	MD	05849	RDS 7 ²⁾	01578
RDD 560/4	07426	1380	15700	69	3610	6.4	7.8	1130	60	40	88.0	MD	05849	RDS 11 ²⁾	01332
Ex Explosion-proof, II 2G Ex h IIB + H ₂ T3 Gb, Motor Ex e, Three phase current, 3~, 400 V, 50 Hz, Protection category IP44															
RDD 560/6 Ex ¹⁾	07432	865	9410	61.5	1100	2.12	2.12	1157	40	40	67.0	MSA	01289	TSD 3	01502

1) Performance diagram at www.HeliosSelect.de.

2) Includes motor protection circuit breaker.

Performance curve VDD 560/4

Frequency	Hz	Tot.	125	250	500	1k	2k	4k	8k
L _{WA} Inlet side	dB(A)	82	71	73	74	75	74	70	63
L _{WA} Outlet side	dB(A)	86	75	79	81	80	76	72	65

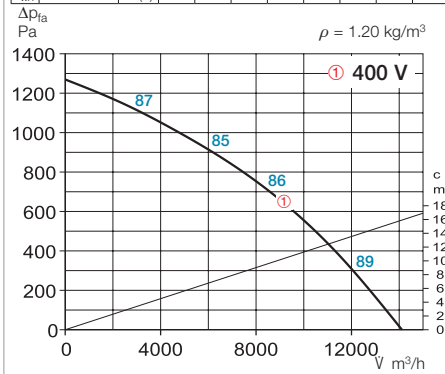

Performance curves VDD 560/6

Frequency	Hz	Tot.	125	250	500	1k	2k	4k	8k
L _{WA} Inlet side	dB(A)	72	61	63	64	65	64	60	53
L _{WA} Outlet side	dB(A)	77	66	70	72	71	67	63	56

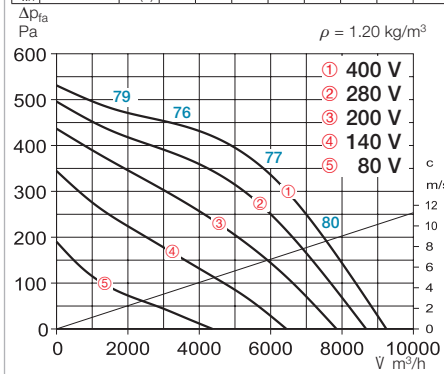

Type	Ref. no.	Speed	Flow rate Free blowing	Noise sound pressure	Power consump.	Current consump.		Wiring diagram	Max. air flow temp.		Weight net	Motor protection circuit breaker		Speed controller 5-step	
						at rated voltage	with control		at rated voltage	with control		Type	Ref. no.	Type	Ref. no.
Three phase current, 3~, 400 V, 50 Hz, Squirrel-cage rotor, Protection category IP54															
VDD 560/6	07422	920	9250	60	1180	3.2	3.2	1129	60	60	75.0	MD	05849	RDS 7 ²⁾	01578
VDD 560/4	07420	1385	14100	69	4430	6.4	—	1130	55	55	77.0	MD	05849	FU-BS 8.0	05461
Ex Explosion-proof, II 2G Ex h IIB + H ₂ T3 Gb, Motor Ex e, Three phase current, 3~, 400 V, 50 Hz, Protection category IP44															
VDD 560/6 Ex ¹⁾	07430	860	8455	60	1090	2.1	2.1	1157	40	40	70.0	MSA	01289	TSD 3	01502
T120 Three phase current, 3~, 400 V, 50 Hz, Squirrel-cage rotor, Protection category IP54 or IP55*															
VDD 560/6 T120 ¹⁾	07439	965	12323	60	1640	3.6	3.5	1264	120	100	92.0	MD	05849	RDS 7 ²⁾	01578
VDD 560/4 T120 ¹⁾	07436	1460	16224	69	5500	11.5	—	1130	120	100	102.0	MSA	01289	FU-BS 10	05462

1) Performance diagram at www.HeliosSelect.de.

2) Includes motor protection circuit breaker.



Impeller
 High-performance centrifugal impeller with backward curved blades made of aluminium. Dynamically balanced according to DIN ISO 21940-11 – quality grade 6.3.

Drive
 Speed-controllable external rotor motor in closed design (IP54) (explosion-proof version in IP44). Flange motor with self-ventilation (T120 version) in IP55. Ball bearing mounted with moisture protection. Maintenance-free and radio interference-free.

Motor protection
 Through built-in thermal contacts or built-in PTC thermistors, which must be connected to a motor protection circuit breaker. Assignment see type table.

Electrical connection
 No dismantling of casing, to external isolator switch (explosion-proof version to terminal box) in protection category IP65.

Protection grille
 On the outlet side as standard according to DIN EN ISO 13857.

Power control
 All types have continuously variable speed control in the range from 0 – 100 % with a frequency inverter with integrated, all-pole effective sine filter (except for explosion-proof version) or five-step control units (except for units with FU). Assignment see type table.

Delivery
 Units are ready-for-connection, fully pre-assembled in the shipping box. Easy positioning due to standard crane hook.

Noise
 The total level and range are specified above the performance diagram for:

- Inlet side sound power
- Outlet side sound power.

The horizontally case-radiated noise as sound pressure at 4 m (free field conditions) is also specified in the type table. Hood silencer see Accessories.

References	Page
Planning information	14 ff.
Technical description	500 f.
Selection table	502 f.
Accessories, details	522 f.
Speed controllers, controllers and switches	599 ff.

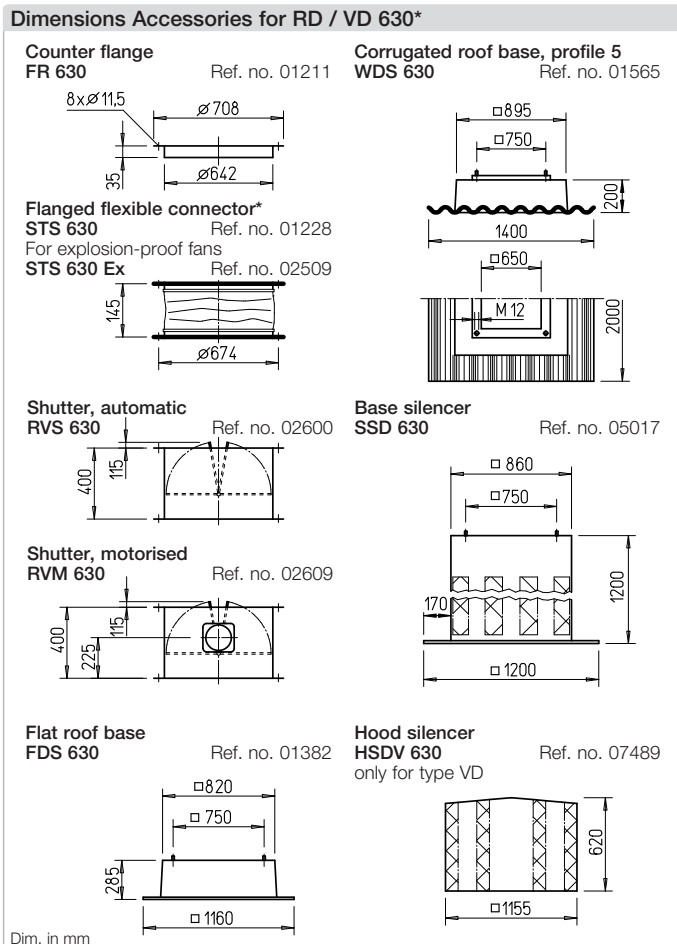
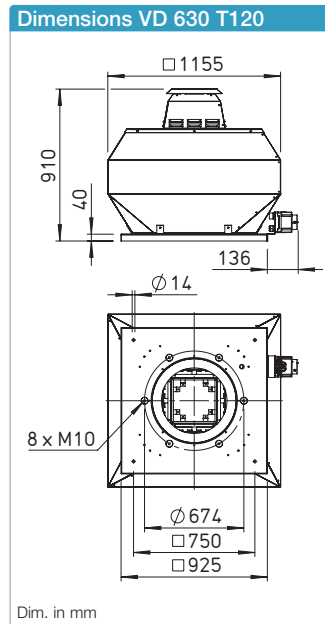
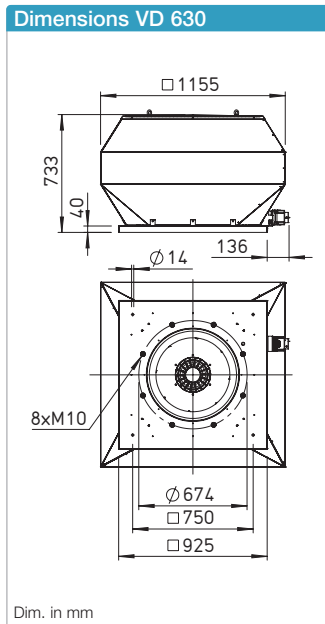
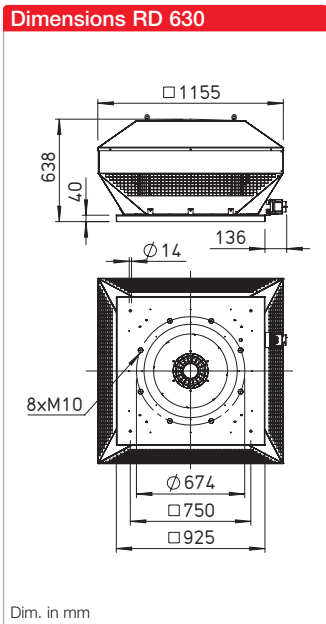

Description RD
 Horizontal outlet roof fan with efficiency-optimised aluminium casing and newly developed high-performance centrifugal impeller.

Description VD
 Vertical outlet roof fan with efficiency-optimised aluminium casing and newly developed high-performance centrifugal impeller.

Description VD T120
 Designed for the delivery of process air up to +120 °C. Enclosed motor located outside of the air flow. Compliant with VDI 2052.

Description of all series

Casing
 Casing made of sea water-resistant aluminium with integrated tamper protection. Motor support plate and base plate with inlet nozzle made of galvanised steel (explosion-proof version inlet nozzle made of aluminium). Base plate with threaded screws for attachment of inlet-side accessories (hole pattern according to DIN 24155).

* Accessories VD T120 see installation accessories p. 523 f. Other accessories upon request.

Performance curves RDD 630/6

Frequency	Hz	Tot.	125	250	500	1k	2k	4k	8k
L _{WA} Inlet side		dB(A)	79	62	69	73	74	72	70
L _{WA} Outlet side		dB(A)	83	67	73	79	78	74	67

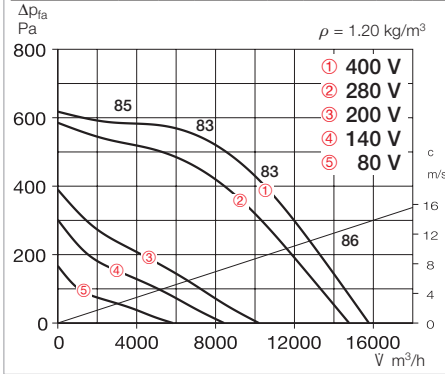

Type	Ref. no.	Speed	Flow rate Free blowing	Noise sound pressure	Power consump.	Current consump.		Wiring diagram	Max. air flow temp.		Weight net	Motor protection circuit breaker		Speed controller 5-step	
						at rated voltage	with control		at rated voltage	with control		Type	Ref. no.	Type	Ref. no.
Three phase current, 3~, 400 V, 50 Hz, Squirrel-cage rotor, Protection category IP54															
RDD 630/6	07447	875	16650	66	2380	4.7	5.2	1129	55	45	92.0	MD	05849	RDS 7²⁾	01578
Explosion-proof, II 3G Ex h IIB + H ₂ T3 Gc, Motor Ex nA, Three phase current, 3~, 400 V, 50 Hz, Protection category IP44															
RDD 630/6 Ex¹⁾	07450	905	16500	67.5	2690	5.4	5.6	1157	40	40	97.0	MSA	01289	TSD 7	01504

1) Performance diagram at www.HeliosSelect.de.

2) Includes motor protection circuit breaker.

Performance curves VDD 630/6

Frequency	Hz	Tot.	125	250	500	1k	2k	4k	8k
L _{WA} Inlet side		dB(A)	78	65	71	72	71	64	57
L _{WA} Outlet side		dB(A)	83	67	76	77	76	71	63

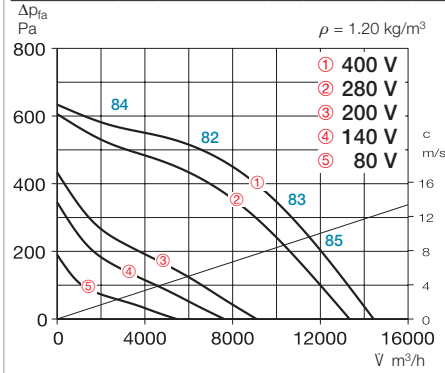

Type	Ref. no.	Speed	Flow rate Free blowing	Noise sound pressure	Power consump.	Current consump.		Wiring diagram	Max. air flow temp.		Weight net	Motor protection circuit breaker		Speed controller 5-step	
						at rated voltage	with control		at rated voltage	with control		Type	Ref. no.	Type	Ref. no.
Three phase current, 3~, 400 V, 50 Hz, Squirrel-cage rotor, Protection category IP54															
VDD 630/6	07441	930	14430	66	2130	4.6	4.95	1129	60	60	96.0	—	—	RDS 7²⁾	01578
Explosion-proof, II 3G Ex h IIB + H ₂ T3 Gc, Motor Ex nA, Three phase current, 3~, 400 V, 50 Hz, Protection category IP44															
VDD 630/6 Ex¹⁾	07448	910	14700	67	2660	5.3	5.5	1157	40	40	101.0	MSA	01289	TSD 7	01504
T120 Three phase current, 3~, 400 V, 50 Hz, Squirrel-cage rotor, Protection category IP55															
VDD 630/6 T120¹⁾	07456	985	19540	69	3160	7.5	7.5	1130	105	—	105.0	MSA	01289	FU-BS 10	05462

1) Performance diagram at www.HeliosSelect.de.

2) Includes motor protection circuit breaker.

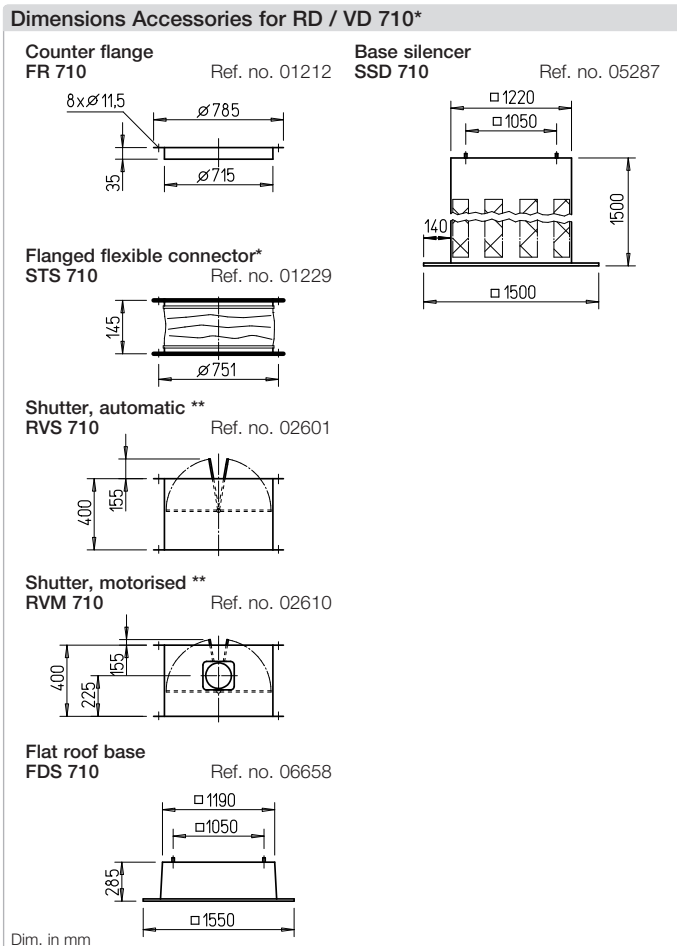
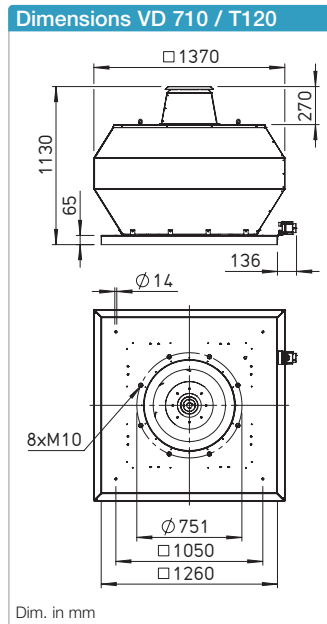
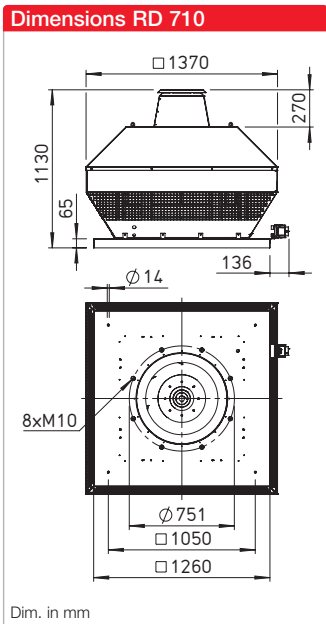

Description RD

Horizontal outlet roof fan with efficiency-optimised aluminium casing and newly developed high-performance centrifugal impeller.

Description VD

Vertical outlet roof fan with efficiency-optimised aluminium casing and newly developed high-performance centrifugal impeller.

Description VD T120

Designed for the delivery of process air up to +120 °C. Enclosed motor located outside of the air flow. Compliant with VDI 2052.

Description of all series

- Protection grille**
 On the outlet side as standard according to DIN EN ISO 13857.
- Power control**
 All types have continuously variable speed control in the range from 0 – 100 % with a frequency inverter with integrated, all-pole effective sine filter.
- Delivery**
 Units are ready-for-connection, fully pre-assembled in the shipping box. Easy positioning due to standard crane hook.
- Noise**
 The total level and range are specified above the performance diagram for:

 - Inlet side sound power
 - Outlet side sound power.

The horizontally case-radiated noise as sound pressure at 4 m (free field conditions) is also specified in the type table.
- Casing**
 Casing made of sea water-resistant aluminium with integrated tamper protection. Motor support plate and base plate with inlet nozzle made of galvanised steel. Base plate with threaded screws for attachment of inlet-side accessories (hole pattern according to DIN 24155).
- Impeller**
 High-performance centrifugal impeller with backward curved blades made of aluminium. Dynamically balanced according to DIN ISO 21940-11 – quality grade 6.3.
- Drive**
 Speed-controllable IEC standard motor with self-ventilation in closed design IP55. Ball bearing mounted with moisture protection. Maintenance-free and radio interference-free.
- Motor protection**
 Through built-in thermal contacts or built-in PTC thermistors, which must be connected to a motor protection circuit breaker. Assignment see type table.
- Electrical connection**
 No dismantling of casing, to external isolator switch in protection category IP65.

References	Page
Planning information	14 ff.
Technical description	500 f.
Selection table	502 f.
Accessories, details	522 f.
Speed controllers, controllers and switches	599 ff.

* Accessories VD T120 see installation accessories p. 523 f. Other accessories upon request.
 ** When used directly under FDS or SSD, an intermediate piece is required (VR 710 K Ref. no. 01429).

Performance curve RDD 710/6

Frequency	Hz	Tot.	125	250	500	1k	2k	4k	8k
L _{WA} Inlet side	dB(A)	83	72	75	75	76	78	72	63
L _{WA} Outlet side	dB(A)	87	72	75	75	76	78	72	63

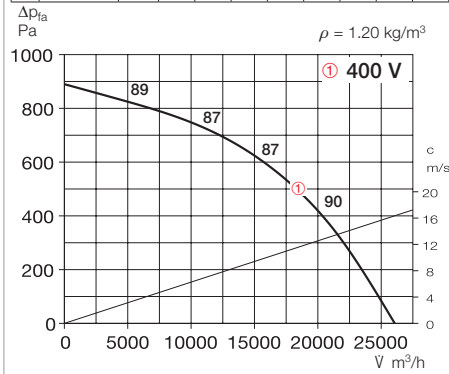

Type	Ref. no.	Speed	Flow rate Free blowing	Noise sound pressure	Power consump.	Current consump.		Wiring diagram	Max. air flow temp.		Weight net	Motor protection circuit breaker		Speed controller 5-step / Frequency inverter	
						at rated voltage	with control		at rated voltage	with control		Type	Ref. no.	Type	Ref. no.
Three phase current, 3~, 400 V, 50 Hz, Squirrel-cage rotor, Protection category IP54															
RDD 710/6	07460	980	26066	70	4300	9.4	—	1130	50	40	187.0	MSA	01289	FU-BS 16	05463

Performance curve VDD 710/6

Frequency	Hz	Tot.	125	250	500	1k	2k	4k	8k
L _{WA} Inlet side	dB(A)	82	71	74	74	75	77	71	62
L _{WA} Outlet side	dB(A)	86	74	76	79	80	81	73	65

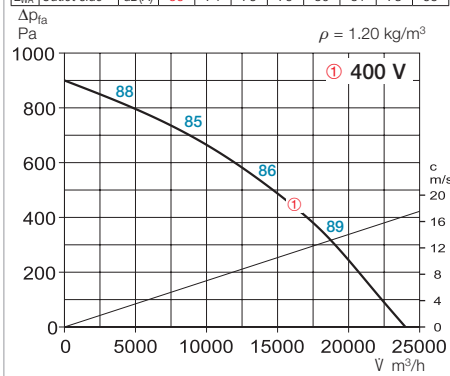

Type	Ref. no.	Speed	Flow rate Free blowing	Noise sound pressure	Power consump.	Current consump.		Wiring diagram	Max. air flow temp.		Weight net	Motor protection circuit breaker		Speed controller 5-step / Frequency inverter	
						at rated voltage	with control		at rated voltage	with control		Type	Ref. no.	Type	Ref. no.
Three phase current, 3~, 400 V, 50 Hz, Squirrel-cage rotor, Protection category IP54															
VDD 710/6	07458	985	23800	69	4270	9.4	—	1130	60	—	185.0	MSA	01289	FU-BS 16	05463
T120 Three phase current, 3~, 400 V, 50 Hz, Squirrel-cage rotor, Protection category IP55															
VDD 710/6 T120 ¹⁾	07466	985	24536	69	4270	9.4	9.4	1130	106	—	185.0	MSA	01289	FU-BS 16	05463

¹⁾ Performance diagram at www.HeliosSelect.de.

HDH



■ **Roof ventilation hoods HDH**
For covering convection vents and supply air openings in the roof. Same design as horizontal outlet roof fans RD.
With regard to mechanical ventilation, the resulting flow losses must be taken into account (see diagrams).
Accessories same as roof fans.

Dimensions HDH

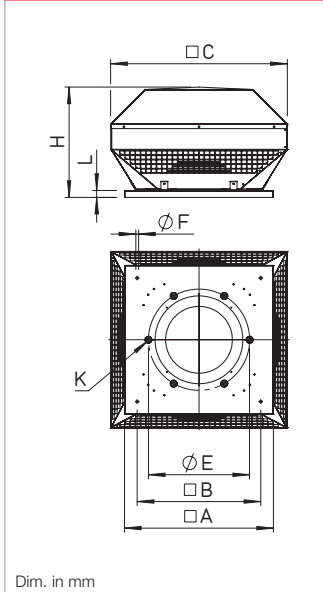

Supply air HDH 180 – 400

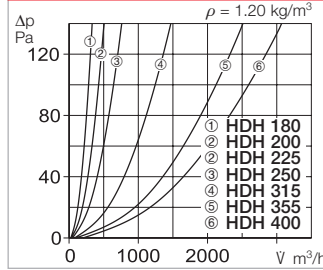

Supply air HDH 450 – 710

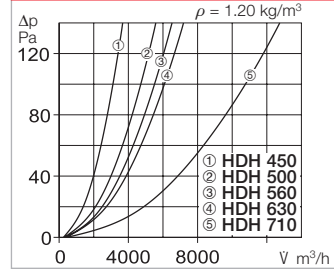

Exhaust air HDH 180 – 355

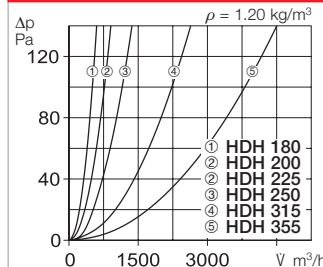

Exhaust air HDH 400 – 710

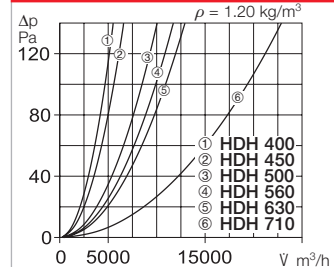

Type	Ref. no.	Nominal size	A	B	C	Ø E	Ø F	H	K	L	Weight net
		mm	mm	mm	mm	mm	mm	mm	mm	mm	approx. kg
HDH 180	07492	180	320	245	309	213	10	155	6 x M6	30	3.5
HDH 200	07493	200	425	330	405	259	10	198	6 x M6	30	5.0
HDH 225	07495	225	425	330	405	259	10	198	6 x M6	30	5.0
HDH 250	07496	250	580	450	450	286	10	255	6 x M6	30	8.0
HDH 315	07497	315	580	450	606	356	12	386	8 x M8	30	12.5
HDH 355	07498	355	645	535	740	395	12	452	8 x M8	30	17.5
HDH 400	07499	400	645	535	765	438	12	478	6 x M8	30	17.5
HDH 450	07491	450	730	590	860	487	12	473	6 x M8	30	26.0
HDH 500	07513	500	925	750	966	541	12	531	6 x M8	40	30.0
HDH 560	07517	560	925	750	1075	605	14	591	8 x M10	40	44.0
HDH 630	07518	630	925	750	1155	674	14	633	8 x M10	40	47.0
HDH 710	07519	710	1260	1050	1370	751	14	860	8 x M10	65	52.0

HSDV

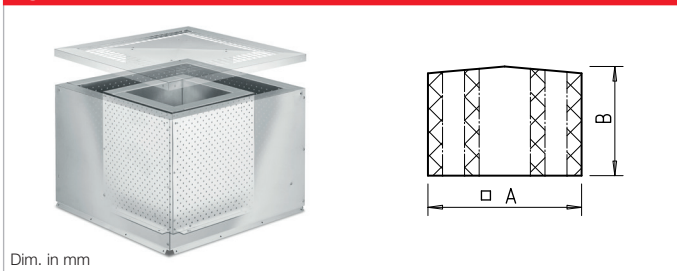

■ **Hood silencer HSDV for outlet side noise reduction**
Average insulation vale 8 dB. Available for series VD, nominal sizes 315 – 630.
The construction is placed on the

roof fan and it can also be retro-fitted without structural alteration. Can only be installed on series VD.

Type	Ref. no.	A	B
HSDV 315	07476	606	310
HSDV 355	07480	740	350
HSDV 400	07481	765	400
HSDV 450	07482	860	450
HSDV 500	07483	966	500
HSDV 560	07484	1075	550
HSDV 630	07489	1155	620

RS



■ **Isolator switch RS RS 3+1+2** Ref. no. 07536
– 3 main contacts
– 1 auxiliary contact
– 2 contacts for TB/TP

For fans with direct start-up. Plastic casing for surface-mounting. Locking options in "0 OFF" position.

■ **Technical data**
Voltage 400 V, 3~, 50/60 Hz
Operating current 20 A
Load capacity AC-23 B, 7.5 kW
Protection category IP 65
Protection class II
Operation Rotary drive
Temp. range –25 to +60 °C
Weight approx. 0.3 kg
Dim. mm W 90.5 x H 90.5 x D 102
Casing UV and weather-resistant
Wiring diagram no. 1131

FR / DFR

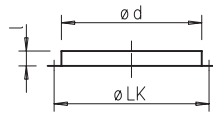

Dim. in mm

Also suitable for:

■ Flange ring FR

Made of galvanised steel sheet, for inlet side duct connection. Directly screwed to the fan base plate.

Dimensions according to DIN 24155, p. 2.

Type	Ref. no.	Ø LK	l	Ø d	Weight approx. kg
FR 180	01200	213	25	186	0.4
DFR 200	01201	259	30	233	0.5
FR 225	01201	259	30	233	0.5
FR 250	01203	286	25	256	0.6
FR 315	01204	356	30	326	0.9
FR 355	01205	395	30	365	1.1
FR 400	01206	438	30	408	1.2
FR 450	01207	487	35	457	1.8
FR 500	01208	541	35	511	1.8
FR 560	01209	605	35	574	2.0
FR 630	01211	674	35	642	2.2
FR 710	01212	751	35	715	3.3

STS / DSTS

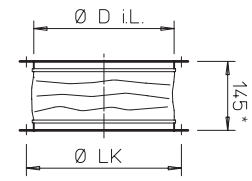

Dim. in mm

Also suitable for:

■ Flanged flexible connector STS

For the prevention of structure-borne sound transmission to inlet side pipes. Flange made of galvanised steel sheet. Elastic sleeve

made of PVC fabric. Use type STS Ex for explosion-proof fans. Directly screwed to the fan base plate. Flange dimensions according to DIN 24155, p. 2. Ambient temperature -30 °C to +80 °C.

Type	Ref. no.	Type*	Ref. no.	Ø D i.L.	Ø LK	Wgt approx. kg
STS 180	01217	—	—	183	213	0.9
DSTS 200	01218	DSTS 200 Ex	02500	229	259	1.1
STS 225	01218	STS 225 Ex	02500	229	259	1.1
STS 250	01220	STS 250 Ex	02501	252	286	1.3
STS 315	01221	STS 315 Ex	02503	322	356	1.8
STS 355	01222	STS 355 Ex	02504	358	395	2.1
STS 400	01223	STS 400 Ex	02505	404	438	2.5
STS 450	01224	STS 450 Ex	02506	453	487	3.8
STS 500	01225	STS 500 Ex	02507	507	541	3.4
STS 560	01226	STS 560 Ex	02508	570	605	4.5
STS 630	01228	STS 630 Ex	02509	638	674	4.6
STS 710	01229	—	—	711	751	7.0

* For explosion-proof fans.

RVS / DVS

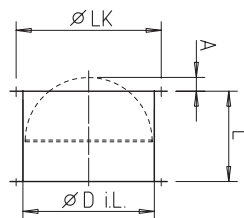

Dim. in mm

Also suitable for:

■ Automatic duct shutter with spring-return RVS¹⁾

For the prevention of cold draughts when the fan is at a standstill. For vertical throughflow from bottom to top (otherwise use type RVM). Automatic function through fan operation. Spring mechanism outside of the air flow. Locking force corresponds to fan power

and the installation position can be adjusted. Shutter and casing made of galvanised steel sheet, shutter made of aluminium for NS 225 – 560 mm. Directly screwed to the fan base plate. Double-sided flange. Holes pursuant to DIN 24155, p. 2.

Ambient temp. -30 to +100 °C

Type	Ref. no.	Ø D i.L.	L	A	Ø LK	Weight approx. kg
DVS 180	01247	180	110	15	213	1.2
DRVS 200	02591	225	300	—	259	3.0
RVS 225	02591	225	300	—	259	3.0
RVS 250	02592	250	300	—	286	3.4
RVS 315	02594	315	300	—	356	4.3
RVS 355	02595	355	300	—	395	5.8
RVS 400	02596	400	330	—	438	7.2
RVS 450	02597	454	330	15	487	10.4
RVS 500	02598	504	330	40	541	11.7
RVS 560	02599	560	330	65	605	16.1
RVS 630	02600	630	400	115	674	19.5
RVS 710	02601	710	400	155	751	26.5

¹⁾ Pressure loss diagram see Page 564.

RVM / DRVM

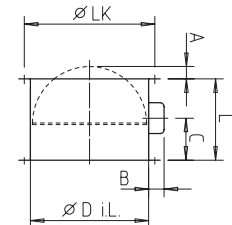

Dim. in mm

■ Motorised shutter RVM^{1) 2)}

Like RVS, but for vertical throughflow in any direction and with a mounted spring return motor (outside of air flow). Allows static ventilation when fan is at a standstill. Supply air control in combination with a roof ventilation hood. Elec. control parallel with fan; cable length 0.9 m, normally closed.

Ambient temp. -30 to +60 °C
Protection category IP54
Volt./Frequency 230 V AC, 50/60 Hz
Power consumption - up to Ø560/from Ø630 14 W/6.5 W
Shutter opening time, aprx. 75 sec.
Wiring diagram no. 380.1

Type	Ref. no.	Ø D i.L.	B	C	L	A	Ø LK	Wgt approx. kg
DRVM 200	02575	225	95	130	300	—	259	3.3
RVM 225	02575	225	95	130	300	—	259	3.3
RVM 250	02576	250	95	130	300	—	286	3.7
RVM 315	02578	315	95	130	300	—	356	4.6
RVM 355	02579	355	95	130	300	—	395	6.1
RVM 400	02580	400	95	130	330	—	438	7.5
RVM 450	02581	454	95	130	330	15	487	10.7
RVM 500	02582	504	95	130	330	40	541	12.0
RVM 560	02583	560	95	130	330	65	605	16.4
RVM 630	02609	630	150	225	400	115	674	21.0
RVM 710	02610	710	150	225	400	155	751	28.0

²⁾ Types DRVM/RVM not suitable for use in potentially explosive atmospheres.

FDS

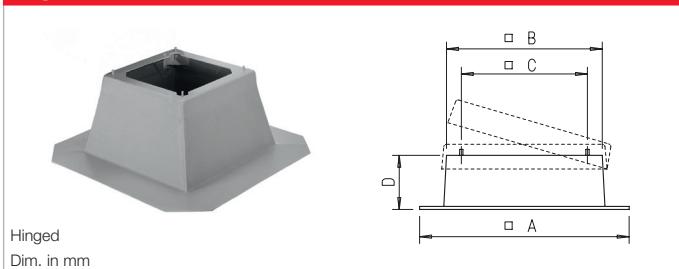

Hinged
Dim. in mm

Flat roof base FDS

For the placement of roof fans and ventilation hoods on flat roofs. Horizontal installation. Use of this base reduces costs and installation expenses to a minimum in comparison to handcrafted designs. Corrosion-resistant GFK version (NS 710 made of galvanised steel sheet) with abrasion-resistant, sound and heat insulation. Snow-safe base height.

Installation

Attach base above the roof opening (roof). Full roof coating over adhesive edge of the base and seal with bitumen fibre filler. Fixing screws, rubber profile and seal between base and base plate included in delivery.

Type	Ref. no.	A	B	C	D
FDS 180*	01377	645	285	245	285
FDS 200*	01378	750	392	330	285
FDS 225*	01378	750	392	330	285
FDS 250*	01379	870	520	450	285
FDS 315*	01379	870	520	450	285
FDS 355*	01380	950	605	535	285
FDS 400*	01380	950	605	535	285
FDS 450*	01381	1000	660	590	285
FDS 500	01381	1160	820	750	285
FDS 560	01382	1160	820	750	285
FDS 630	01382	1160	820	750	285
FDS 710	06658	1550	1190	1050	285

* With hinge mechanism for easy inspection and cleaning.

SSD

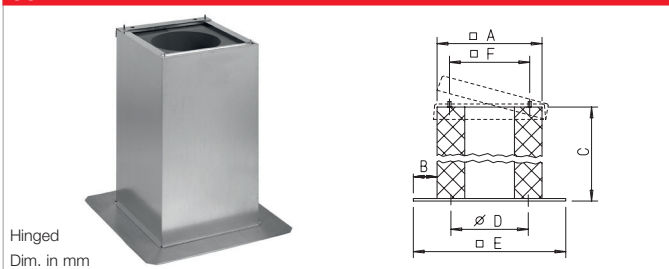

Hinged
Dim. in mm

Base silencer SSD for inlet-side sound insulation

Average insulation value 15 dB. All metal parts made of galvanised steel sheet. For installation on flat roofs in the same way as the flat roof base. Fixing screws, rubber profile and seal between base and base plate included in delivery. For NS 500–710: Sound insulation baffles with insulation board made

of non-combustible material, class A2, wrapped in glass fibre mat on both sides. NS 180–450: With hinge for folding the fan down for inspection purposes. Foam core with free cross-section allows access to the duct/shaft system. Base plate is equipped with threaded bushes (according to DIN 24155, p. 2) for the connection of inlet side accessories.

Type	Ref. no.	A	B	C	D	E	F
SSD 180*	05289	280	160	750	213	600	245
SSD 200*	05290	400	133	735	259	666	330
SSD 225*	05290	400	133	735	259	666	330
SSD 250*	05292	520	150	835	286	795	450
SSD 315*	05292	520	150	835	356	795	450
SSD 355*	05024	600	150	985	395	900	535
SSD 400*	05291	600	150	985	438	900	535
SSD 450*	05288	675	158	985	487	990	590
SSD 500	05017	860	170	1200	–	1200	750
SSD 560	05017	860	170	1200	–	1200	750
SSD 630	05017	860	170	1200	–	1200	750
SSD 710	05287	1220	140	1500	–	1500	1050

* With hinge mechanism for easy inspection and cleaning.

WDS

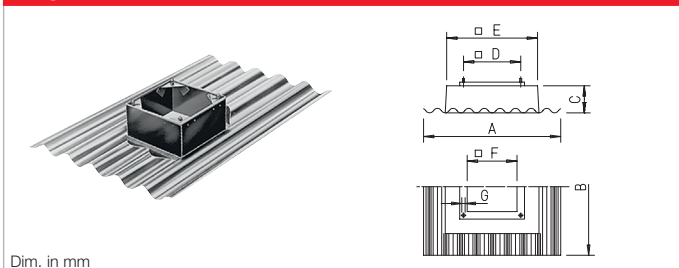

Dim. in mm

Corrugated roof base WDS

For the placement of roof fans and ventilation hoods on corrugated roofs. Weather-resistant and non-corrosive design made of glass-fibre reinforced polyester with a low deadweight. No risk of breakage during shipping and on the construction site. Low thermal transmittance value. Corrugation spacing 177 mm (profile no. 5). Use of this base costs for

planning, design and installation to a minimum. Rain drains on the front and back grooves between the square base and the corrugated plate allow installation of the corrugated roof plate regardless of the assembly direction. Screws, washers and rubber profile for attaching and sealing the fan-base plate included in the delivery.

Type	Ref. no.	A	B	C	D	E	F	G
WDS 180	01559	920	1600	200	245	295	Ø 256	M 6
WDS 200/225	01560	920	1600	200	330	395	290	M 10
WDS 250/315	01561	920	1600	200	450	555	395	M 10
WDS 355/400	01562	920	1600	200	535	625	475	M 10
WDS 450	01563	1400	2000	200	590	705	525	M 12
WDS 500/560	01564	1400	2000	200	750	895	650	M 12
WDS 630	01564	1400	2000	200	750	895	650	M 12

SDS

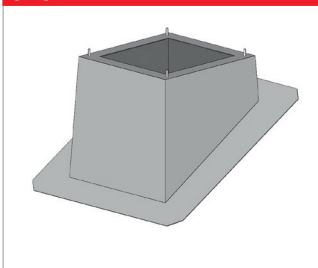

Pitched roof base SDS

For the placement of roof fans and ventilation hoods on pitched roofs with up to 45° inclination. Made of galvanised steel sheet, with sound and heat insulated 50 mm thick lining on the inside.

All SDS types are available upon request. Please specify the fan type or nominal size of the ventilation hood, roof inclination angle, brick type or, if applicable, the profile shape and height (for profile roofs) when ordering.

Installation

Attach base to roof construction. Seal against roofing with surrounding lead collar. Screws, washers and seal between base and fan/hood base plate included in the delivery.

References Page

All centrifugal roof fans do not have protection grilles on the inlet side. If the installation does not ensure protection against unintentional contact, the corresponding contact protection (grille type ASD-SGD or SG) must be attached. 277

Other accessories Page

Speed controllers, controllers and switches 599 ff.