

Competence in aerodynamics. Axial fans without limits.



As a leading European fan manufacturer, Helios offers an exceptional, finely tuned series range of high performance and medium pressure axial fans and RADAX® VAR high pressure round duct fans in all performance ranges.

The series range of high performance axial fans with aerodynamically and acoustically optimised impellers and innovative motor concepts (Ø 250 to 500 mm) is presented on the following pages.

The especially **energy-saving EC models** with speed control achieve energy savings of more than 55% in comparison to conventional AC types.

Voltage controllable high performance axial AC fans in Ø 250 to 500 mm are characterised by their proven robust design and a 25% increase in efficiency with 50% noise reduction.

The series range with Ø up to 1000 mm is complemented by technical building equipment (TGA) solutions.

■ Fire gas and smoke extraction types according to DIN 12101-3 in temperature classes F300 (60 min.), F400 (120 min.) and F600 (120 min.).
See TGA catalogue, Ref. no. 86979.

■ Special technical building equipment (TGA) solutions and large axial fans from Ø 1000 to 7100 mm, V up to 2.2 million m³/h, are manufactured according to customer-specific requirements.

Renowned users rely on the application of Helios axial fans in ventilation, heating, cooling, air conditioning and drying systems around the world.

The large fans have been used successfully for decades, e.g. in cooling towers and air coolers.

■ High performance axial fans

Energy-efficient EC version.

Ø 250 – 710 mm
 V = 1970 – 19 400 m³/h



182^f

■ High performance axial fans

Standard AC version.

Ø 200 – 1000 mm
 V = 520 – 63 420 m³/h



Also available in version:



200^f

■ High performance axial fans

Product-specific information, selection table.

180^f

Axial and VAR fans

■ Medium pressure axial fans

Product-specific information, selection table.

Ø 225 – 630 mm
 V = 950 – 32 000 m³/h



226^f

■ RADAX® VAR high pressure fans

Product-specific information, selection table.

Ø 225 – 630 mm
 V = 900 – 22 310 m³/h

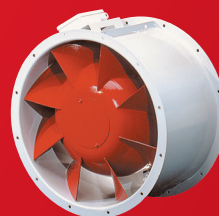

Also available in version:



252^f

■ Installation accessories

For axial fans and VAR fans.

276^f

This information supplements the "General technical information".

■ Designs

- Standard and high performance fans in industrial design are manufactured in series with more than 20 nominal sizes and more than 1000 types.
- A closely graduated range up to impeller Ø 7100 mm in various designs is available for higher volume and pressure rates. Four different versions are available as standard.
- Types HQ, HW and HRF up to nominal size 500 mm with highly efficient EC drive technology are optionally available for especially energy-efficient applications and minimal operating costs.

■ Versions in this catalogue

1. Wall fan HQ

Square plate with intake nozzle

Casing made of galvanised steel sheet. Motor with terminal box and protection grille on inlet side.

2. Built-in fans

HW, AVD DK

Wall ring with intake nozzle

Casing made of galvanised steel sheet. Motor with terminal box and protection grille on inlet side.

3. Built-in wall fan HS

Pipe sleeve, cylindrical with smooth ends

For flush-mounted wall or duct installation. Casing made of galvanised steel sheet with circumferential reinforcing beads.

4. Round duct fans

HRF, AVD RK

Pipe sleeve, with double-sided flanges

For direct intermediate flanges in pipeline. Flange in accordance with DIN 24155, p. 3. Casing made of galvanised steel sheet, with additional terminal box (IP55) on outside of duct.

■ Drive

AC types

Robust 1~ or 3~ internal rotor motors with thermal contacts in the winding. Ball bearings with lifetime lubrication.

EC types

Highly efficient, speed-controllable external rotor motors in protection category IP54. Ball bearings with lifetime lubrication.

■ Impellers

- Depending on requirements, the impellers are made of different materials; see information on the product pages. The standard versions are made of plastic, but other materials e.g. aluminium or steel are possible according to requirements.

- Common features:**
 - Low operating noise level.
 - High level of efficiency.
 - Vibration-free running due to dynamic balancing in accordance with DIN ISO 21940-11 – quality grade 6.3.
- Impellers made of other materials are possible upon request.
- Impellers made of metal are available at an extra charge for higher temperatures. The information on the product pages is decisive.

■ Angle of attack

- The series products up to 630 mm Ø are equipped with fixed impellers.
- The blades can be delivered with order-based angles of attack from nominal size 710 mm upwards (except for type HQW 710/6).
- The sizes Ø 800/4, 900/4 and/6 as well as Ø 1000 mm have blades which can be adjusted at standstill. This allows optimal coverage of the operating point. The angle of attack is adjusted (according to the order) and fixed in the factory. The motor is assigned using the maximum power (see table). The specified angle of attack must not be exceeded, otherwise the motor can be overloaded.

■ Contact protection

With regard to installation and operation, The applicable occupational safety and accident protection guidelines as well as contact protection according to VDE 0700 or DIN EN ISO 13857 must be observed. Contact with rotating parts must be prevented. It must be ensured that there are no loose substances in the intake area. Fans which are protected by their installation type (e.g. installation in ventilation duct or closed aggregates) do not require a protection grille if the system provides sufficient safety. Please note that the installer can be held liable for accidents as the result of the lack of protection devices. Suitable protection grilles are available as accessories. The installer and operator shall be responsible for observing safety regulations.

Air flow direction

All fans (except for HRF and AVD RK) are designed with air flow direction
A = inlet over motor
B = outlet over motor
 can be delivered for most types upon request (at an extra charge).
 HRF and AVD RK are delivered with air flow direction B as standard.

- The subsequent conversion of air flow direction is possible for most high performance axial AC fans. This requires the following:
 1. Change of direction of motor rotation by reversing the polarity on the terminal board.
 2. Removal of the impeller and reattachment the other way round (possible up to Ø 500). A performance reduction of approx. 1/3 should be expected for series HQ and HW.
- EC types can only be operated in the standard direction of rotation.

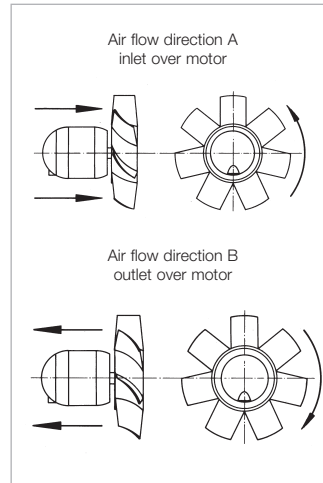

■ Installation position, installation, condensate outlets

- Axial fans can be installed and operated in any position in compliance with the permissible protection category (see product page). In case of equipment with condensate drain holes, please be aware of their position.
- In case of outdoor installation, installation in permanently humid or wet environments or in case of installation with a vertical shaft, this must be indicated when placing the order, because a special design may be required. The installation site and mounting should be such that the fan can be mounted securely and without warping.

■ Reverse operation

Most high performance axial AC fans (see product pages) are reversible. Either supply or extract ventilation can take place using a suitable reverser switch. There is a performance reduction of approx. 1/3 in an abnormal flow direction.

- The EC types are non-reversible as standard.

■ Air flow temperatures

Temporarily higher air flow temperatures are also possible with the exception of explosion-proof versions. Versions designed for higher continuous temperatures

are possible in the area of custom production.

■ Motor protection

- Through built-in thermal contacts in the winding for AC types
 - standard for 1~ motors,
 - mostly standard for 3~ motors (see product page).
- Integrated electronic temperature monitoring system for EC types.
- The regulations DIN EN 60079-10 shall apply for explosion-proof types. According to this, overload protection must be provided for each fan by a motor protection circuit breaker, which must be triggered within the heating time specified in the test certificate in case of a short circuit. Fans must be protected by a protection grille or shutter against foreign bodies larger than 12 mm getting sucked in or falling in. Approved operating mode according to DIN EN 60034-1/VDE 0530 = S1 (continuous operation). Speed control is not permitted.

■ Explosion protection

The explosion-proof types correspond to unit group II, category 2G for operation in zone 1 and 2. Larger air gaps which result in a performance reduction of approx. 10% are stipulated in accordance with Directive 2014/34/EU (ATEX).

■ Special equipment, Additional costs upon request

- Impeller made of die-cast aluminium**
- Deviating voltage**
- Deviating frequency**
- Two-component lacquer coating (RAL 6011)** to protect the external unit parts against weak acids and alkaline solutions
- Deviating air flow direction**
- Special equipment for higher air flow temperatures**
- Pressure-resistant encapsulated motors (standard for 1~ explosion-proof types)**

■ Vibration insulation

The use of vibration dampers (accessories SDD, SDZ) is recommended to prevent vibration transmission. Larger motors may protrude from the back and cause uneven distribution due to their high weight. An extension duct VR (accessories) should be provided to adjust the centre of gravity.

By combining the parameters of static pressure increase Δp_{ia} , flow rate V , speed min^{-1} , sound pressure level dB(A) and impeller diameter DN mm, the following table facilitates the selection of high performance

axial EC fans \varnothing 250 to 710 mm and high performance axial fans \varnothing 200 to 1000 mm.

	Speed	Sound pressure inlet side L_{PA} dB(A) at 4 m distance	Flow rate V m ³ /h depending on static pressure																
			(Δp_{ia}) in Pa																
			0	10	20	30	40	50	60	80	100	120	140	160	200	250	300	350	400
\varnothing in mm	min^{-1}	at 4 m distance	0	10	20	30	40	50	60	80	100	120	140	160	200	250	300	350	400
EC 250 A	2710	58	1970	1940	1900	1820	1790	1750	1680	1540	1330	1120	760						
EC 315 A	1920	52	2780	2740	2690	2600	2510	2420	2330	2160	1800								
EC 355 A	1460	49	2990	2910	2660	2490	2410	2240	2070										
EC 355 B	1975	59	4200	4150	4090	4020	3960	3890	3820	3690	3540	3360	3100	2790					
EC 400 A	1800	59	4790	4690	4610	4540	4460	4390	4310	4140	3920	3640	3240						
EC 400 B	2150	65	5850	5800	5760	5700	5640	5560	5490	5360	5210	5080	4870	4730	4030				
EC 450 A	1325	55	5460	5350	5250	5140	5030	4910	4790	4520	4200	3730							
EC 450 B	1835	64	7640	7580	7510	7450	7390	7330	7260	7070	6880	6680	6490	6200	5530				
EC 500 A	1025	54	6320	6190	6050	5900	5750	5590	5420	5010	4460								
EC 500 B	1450	62	8300	8230	8150	8070	7970	7880	7790	7490	7300	6910	6530	6140					
EC 560	1200	55	9740	9550	9360	9160	8780	8590	8400	8020	7440	6480							
EC 630	960	54	10330	10100	9860	9630	9400	8930	8700	7770	6370								
EC 710	1100	61	19400	18920	18440	18210	17970	17490	17240	16530	15570	14610	13650	11260					

\varnothing in mm	Speed	Sound pressure inlet side L_{PA} dB(A) at 4 m distance	Flow rate V m ³ /h depending on static pressure																
			(Δp_{ia}) in Pa																
			0	10	20	30	40	50	60	80	100	120	140	160	200	250	300	350	400
200	2300	55	910	860	810	760	710	490	420	330	220								
200	1360	42	520	410	210	170													
250	2800	53	2070	2040	2010	1970	1940	1910	1870	1800	1710	1610	1480						
250	1450	44	930	840	730														
250	950	31	660	570															
315	2800	69	4090	4050	4020	3990	3950	3920	3880	3790	3700	3610	3500	3380	3090				
315	1450	51	2090	2010	1930	1840	1740	1620	1410										
315	950	38	1330	1220	1070														
315	725	30	980	780															
355	2800	71	5710	5670	5620	5580	5530	5480	5430	5330	5220	5110	4990	4860	4550	4020			
355	1450	51	2850	2770	2670	2570	2450	2320	2160										
355	950	42	1940	1830	1690	1500	1060												
355	725	34	1430	1240	880														
400	2800	71	8410	8360	8310	8270	8220	8170	8130	8030	7940	7840	7750	7650	7440	7160	6840	6440	5820
400	1450	56	4010	3920	3810	3700	3580	3440	3300	2970									
400	950	45	2570	2410	2230	2020													
400	725	37	2010	1810	1530														
450	2800	78	11050	10960	10870	10770	10680	10590	10500	10310	10130	9950	9770	9580	9210	8690	8050	6930	4520
450	1450	58	5770	5680	5590	5500	5390	5280	5160	4870	4510	4010							
450	950	47	3890	3720	3550	3360	3150	2890											
450	725	51	2860	2680	2450	2120													
500	2800	81	13150	13040	12930	12820	12720	12610	12500	12290	12070	11860	11660	11440	11010	10380	9600	8620	5390
500	1450	65	8320	8220	8110	8000	7880	7760	7630	7370	7080	6760	6400	5970					
500	950	51	5500	5330	5140	4950	4740	4510	4240	3450									
500	725	44	3890	3690	3440	3150	2750												
560	1450	62	12910	12680	12550	12360	12140	11950	11770	11320	10900	10550	10000	9500	8270				
560	950	52	8100	7680	7370	7080	6680	6280	5830	4570									
560	725	46	6450	6070	5640	5230	4750	4140											
630	1450	65	17870	17650	17420	17200	16970	16750	16520	16010	15500	15000	14500	14000	13000	11300			
630	950	55	10520	10150	9780	9410	9040	8670	8220	7260									
630	725	49	8000	7580	7010	6530	5910	5300											
710	1450	71	23740	23490	23240	22980	22730	22470	22200	21660	21090	20500	19900	19290	18010	16240	14000	11060	
710	935	61	15250	14860	14450	14040	13590	13140	12600	11690	10610	9280	7440						
710	700	54	11350	10810	10250	9630	8990	8300	7500	5340									
800	1435	73	32350	32040	31720	31400	31090	30770	30490	29860	29230	28610	27990	27330	25940	24020	22080		
800	945	62	20720	20280	19830	19350	18850	18290	17710	16530	15330	13840	10740						
800	705	55	15380	14780	14120	13380	12580	11790	10900										
900	1435	76	46060	45700	45390	45030	44670	44310	44000	43280	42600	41880	41170	40800	39060	37110	34940	32800	30340
900	950	66	30500	30100	29500	29100	28500	27900	27400	26300	25100	23910	22710	21310					
900	725	59	21160	20410	19640	18850	18010	17120	16130	15000									
1000	1440	80	63420	63030	62650	62260	61870	61490	61110	60330	59560	58790	58010	57240	55700	53710	51590	49260	46830
1000	950	69	41740	41150	40570	39990	39400	38810	38230	37060	35870	34610	33260	31810	28880				
1000	725	62	31760	30990	30220	29460	28690	27930	27130	25410	23500	21540							

Axial and VAR fans

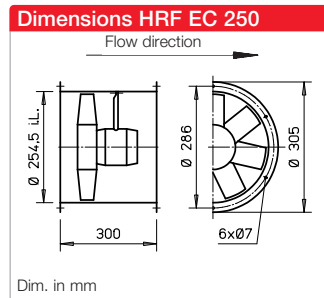
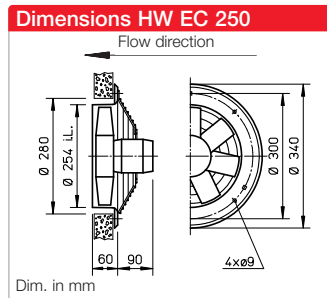
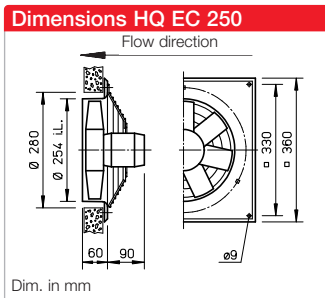

Description for all types

- **Casing**
 Made of galvanised steel sheet, types HQ and HW have additional two layer lacquer coating in papyrus white.
- **Impeller**
 High performance characteristics with profiled blades made of plastic, aerodynamically optimised for application, dynamically balanced.
- **Drive**
 Energy-saving, speed-controlable external rotor EC motor in protection category IP54 with the highest level of efficiency. Maintenance-free and radio interference-free, excellent electromagnetic compatibility (EMC), ball bearing mounted.
- **Motor protection**
 Integrated electronic temperature monitoring system for EC motor and electronics.

- **Electrical connection**
 Standard terminal box (protection category IP54) mounted to external cable, or on outside of duct for HRF.
- **Protection grille**
 Made of powder-coated steel for HQ and HW in accordance with DIN EN ISO 13857.
- **Power control**
 All types are continuously controllable via internal (delivery) or external speed potentiometer. Control is also possible via three level switch or continuously variable via universal control system or electronic differential pressure/temperature controller. See type table. Performance levels are shown on the performance curve as examples.

- **Installation**
 Installation possible in any position.
- **Noise levels**
 The total level and range for the sound power level and sound pressure level at 4 m free field conditions are specified above the performance diagram for the average operating point on the inlet/outlet side. The total sound pressure level at 4 m (free field conditions) is also specified in the table below the performance diagram for various voltages. See page 14 f for noise emissions and room acoustics.

Speed	Flow rate-free-blowing	Power consump.	Current consum.	Sound pressure	Wiring diagram	Max. air flow temperature	Wgt net	Design type						
								HQ EC incl. protection grille	Ref. no.	HW EC incl. protection grille	Ref. no.	HRF EC	Ref. no.	
min ⁻¹	V m ³ /h	kW	A	dB(A) at 4m	No.	+°C	ca. kg							
Alternating current, 1~, 230 Volt, 50/60 Hz, EC motor, protection category IP54														
2710	1970	0.13	1.03	58	1252	40	6.0	HQW EC 250 A	04822	HWW EC 250 A	04823	HRFW EC 250 A	04824	

Performance curves HQ EC / HW EC / HRF EC 250 A

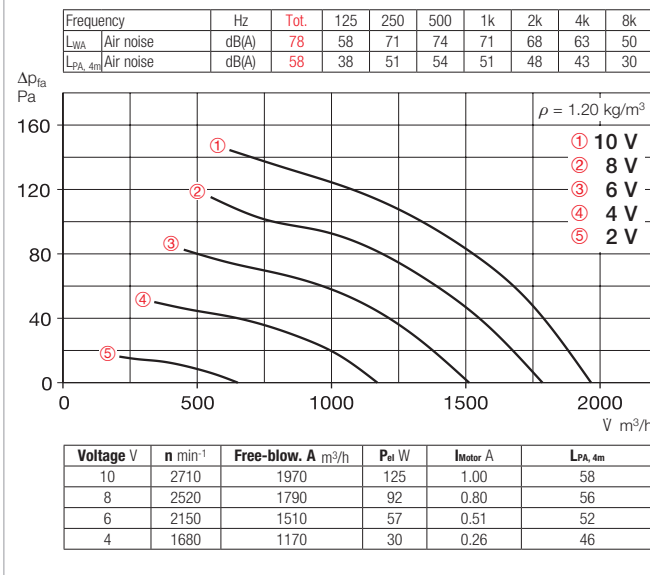

Accessories for HRF EC 250 Description see page 276 ff.

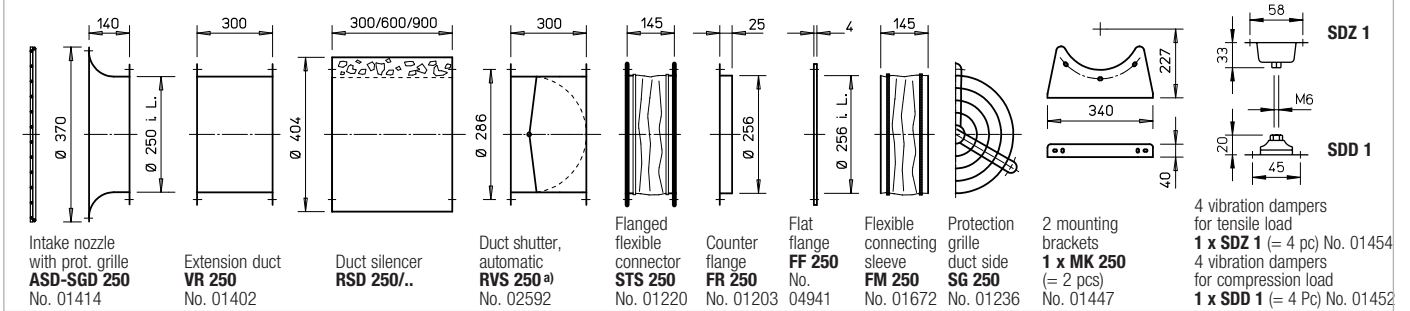

^{a)} Shutter, motorised see Accessories product pages.

References	Page
Techn. description	180
Selection table	181
Planning information	14 ff.

Special design
Different voltage, air flow direction, higher air flow temperature, acid protection upon request.

The technical information on p.19 ff. must be observed.

Other accessories	Page
Filters and silencers	481 ff.
Shutters and ventilation grilles	561 ff.
Universal control system, electronic controller, Speed potentiometer	613 ff.

Universal control system		Speed potentiometer		Three level speed switch		Electronic pressure difference controller/ actuator		Electronic temperature controller/actuator					
Type	Ref. no.	Type	Ref. no.	Type	Ref. no.	Type	Ref. no.	Type	Ref. no.				
EUR EC ¹⁾	01347	PU 10 ¹⁾	01734	PA 10 ¹⁾	01735	SU-3 10 ¹⁾	04266	SA-3 10 ¹⁾	04267	EDR ¹⁾	01437	ETR ¹⁾	01438

¹⁾ Multiple EC fans can normally be connected, see Accessories.

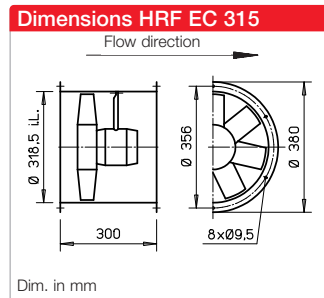
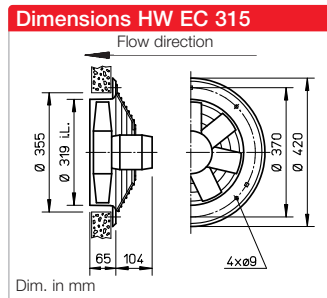
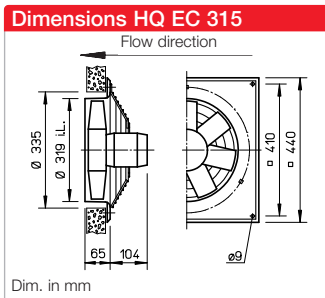

Description for all types

■ **Casing**
 Made of galvanised steel sheet, types HQ and HW have additional two layer lacquer coating in papyrus white.

■ **Impeller**
 High performance characteristics with profiled blades made of plastic, aerodynamically optimised for application, dynamically balanced.

■ **Drive**
 Energy-saving, speed-controllable external rotor EC motor in protection category IP54 with the highest level of efficiency. Maintenance-free and radio interference-free, excellent electromagnetic compatibility (EMC), ball bearing mounted.

■ **Motor protection**
 Integrated electronic temperature monitoring system for EC motor and electronics.

■ **Electrical connection**
 Standard terminal box (protection category IP54) mounted to external cable, or on outside of duct for HRF.

■ **Protection grille**
 Made of powder-coated steel for HQ and HW in accordance with DIN EN ISO 13857.

■ **Power control**
 All types are continuously controllable via internal (delivery) or external speed potentiometer. Control is also possible via three level switch or continuously variable via universal control system or electronic differential pressure/temperature controller. See type table. Performance levels are shown on the performance curve as examples.

■ **Installation**
 Installation possible in any position.

■ **Noise levels**
 The total level and range for the sound power level and sound pressure level at 4 m free field conditions are specified above the performance diagram for the average operating point on the inlet/outlet side. The total sound pressure level at 4 m (free field conditions) is also specified in the type table, as well as the table below the performance diagram for various voltages. See page 14 f for noise emissions and room acoustics.

Speed	Flow rate-free-blowing	Power consump.	Current consum.	Sound pressure	Wiring diagram	Max. air flow temperature	Wgt net	Design type					
								HQ EC incl. protection grille	Ref. no.	HW EC incl. protection grille	Ref. no.	HRF EC	Ref. no.
min ⁻¹	V m ³ /h	kW	A	dB(A) at 4m	No.	+°C	ca. kg						
Alternating current, 1~, 230 Volt, 50/60 Hz, EC motor, protection category IP54													
1920	2780	0.15	1.20	52	1252	40	7.5	HQW EC 315 A	04880	HWW EC 315 A	04881	HRFW EC 315 A	04882

Performance curves HQ EC / HW EC / HRF EC 315 A

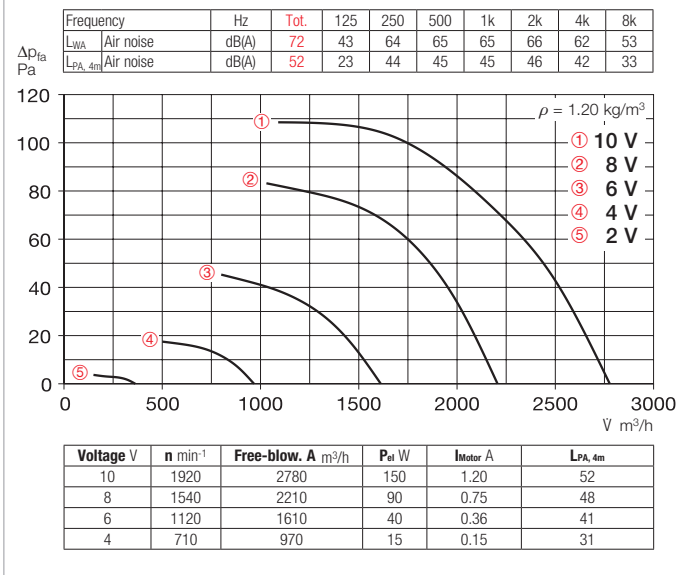

Accessories for HRF EC 315 Description see page 276 ff.

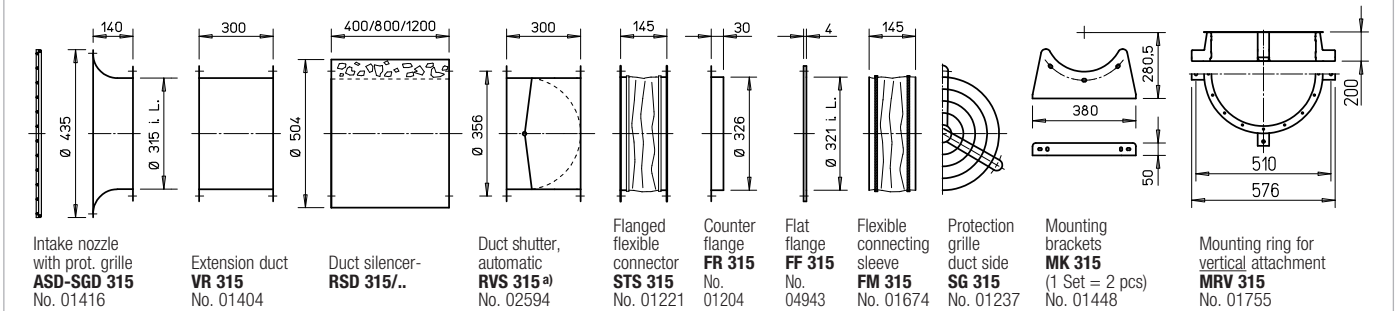

a) Shutter, motorised see Accessories product pages.

References	Page	Other accessories	Page
Techn. description	180	Filters and silencers	481 ff.
Selection table	181	Shutters and ventilation grilles	561 ff.
Planning information	14 ff.	Universal control system, electronic controller, Speed potentiometer	613 ff.

Special design
Different voltage, air flow direction, higher air flow temperature, acid protection upon request.

The technical information on p.19 ff. must be observed.

Universal control system		Speed potentiometer		Three level speed switch		Electronic pressure difference controller/ actuator		Electronic temperature controller/actuator					
Type	Ref. no.	Type	Ref. no.	Type	Ref. no.	Type	Ref. no.	Type	Ref. no.				
EUR EC ¹⁾	01347	PU 10 ¹⁾	01734	PA 10 ¹⁾	01735	SU-3 10 ¹⁾	04266	SA-3 10 ¹⁾	04267	EDR ¹⁾	01437	ETR ¹⁾	01438

1) Multiple EC fans can normally be connected, see Accessories.

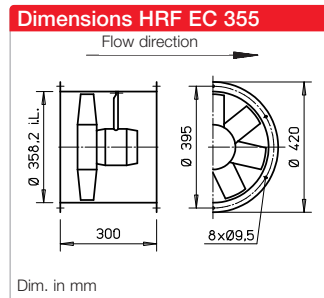
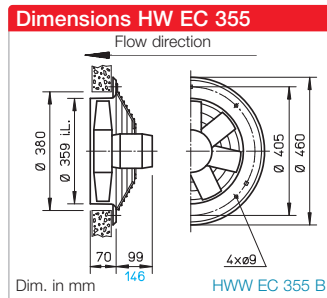
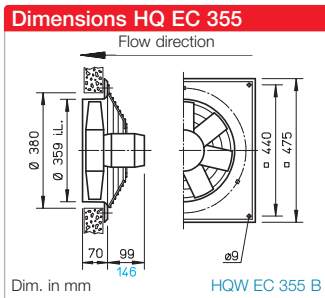

Description for all types

Casing
 Made of galvanised steel sheet, types HQ and HW have additional two layer lacquer coating in papyrus white.

Impeller
 High performance characteristics with profiled blades made of plastic, aerodynamically optimised for application, dynamically balanced.

Drive
 Energy-saving, speed-control-able external rotor EC motor in protection category IP54 with the highest level of efficiency. Maintenance-free and radio interference-free, excellent electromagnetic compatibility (EMC), ball bearing mounted.

Motor protection
 Integrated electronic temperature monitoring system for EC motor and electronics.

Electrical connection
 Standard terminal box (protection category IP54). Mounted to external cable for HQ and HW types (version "A") or on back of motor (version "B"). Mounted on outside of duct for HRF types.

Protection grille
 Made of powder-coated steel for HQ and HW in accordance with DIN EN ISO 13857.

Power control
 All types are continuously controllable via internal (delivery) or external speed potentiometer. Control is also possible via three level switch or continuously variable via universal control system or electronic differential pressure/temperature controller. See type table. Performance levels are shown on the performance curve as examples.

Installation
 Installation possible in any position.

Noise levels
 The total level and range for the sound power level and sound pressure level at 4 m free field conditions are specified above the performance diagram for the average operating point on the inlet/outlet side. The total sound pressure level at 4 m (free field conditions) is also specified in the type table, as well as the table below the performance diagram for various voltages. See page 14 f for noise emissions and room acoustics.

Speed	Flow rate-free-blowing	Power consump.	Current consump.	Sound pressure	Wiring diagram	Max. air flow temperature	Wgt net	Design type					
								HQ EC incl. protection grille	Ref. no.	HW EC incl. protection grille	Ref. no.	HRF EC	Ref. no.
min ⁻¹	V m ³ /h	kW	A	dB(A) at 4m	No.	+°C	ca. kg						
Alternating current, 1~, 230 Volt, 50/60 Hz, EC motor, protection category IP54													
1460	3000	0.12	1.10	49	1252	40	8.5	HQW EC 355 A	04916	HWW EC 355 A	04917	HRFW EC 355 A	04918
1980	4200	0.32	1.40	59	1047	40	12.0	HQW EC 355 B	04919	HWW EC 355 B	04920	HRFW EC 355 B	04921

Performance curves HQ EC / HW EC / HRF EC 355 A

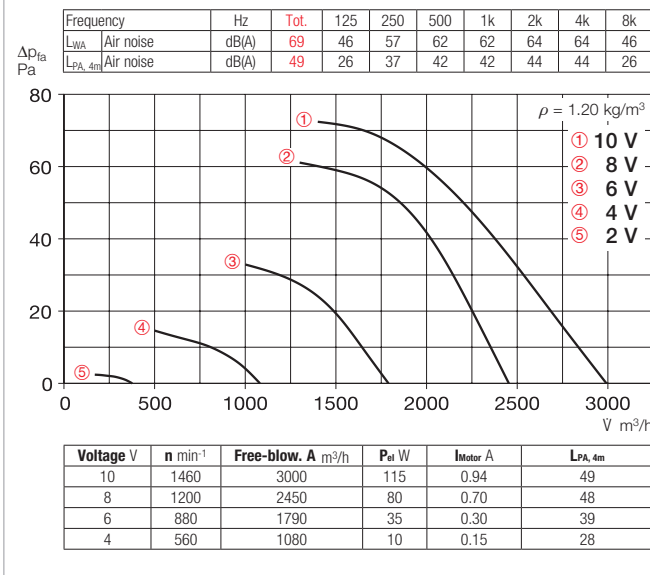

Performance curves HQ EC / HW EC / HRF EC 355 B

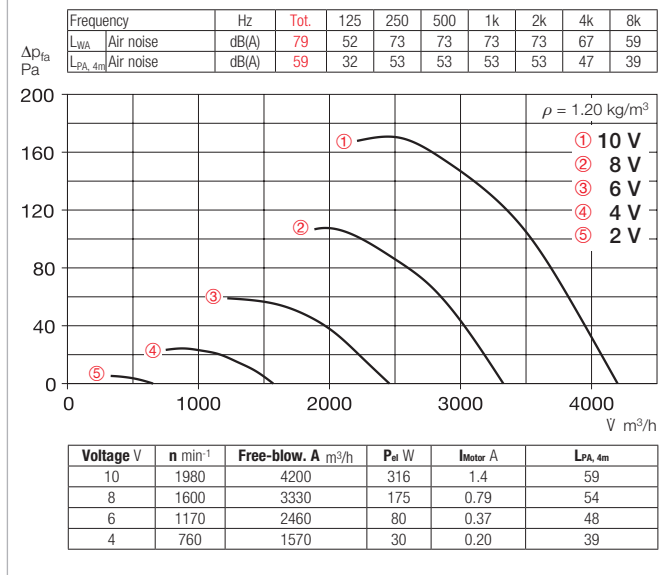

Accessories for HRF EC 355 Description see page 276 ff.

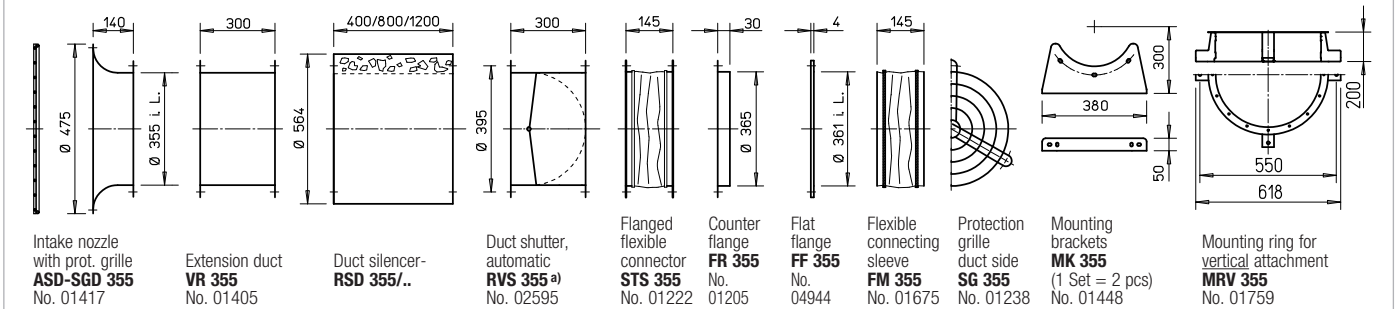

a) Shutter, motorised see Accessories product pages.

References	Page
Techn. description	180
Selection table	181
Planning information	14 ff.

Special design
Different voltage, air flow direction, higher air flow temperature, acid protection upon request.

The technical information on p.19 ff. must be observed.

Other accessories	Page
Filters and silencers	481 ff.
Shutters and ventilation grilles	561 ff.
Universal control system, electronic controller, Speed potentiometer	613 ff.

Universal control system		Speed potentiometer		Three level speed switch		Electronic pressure difference controller/ actuator		Electronic temperature controller/actuator					
Type	Ref. no.	Type	Ref. no.	Type	Ref. no.	Type	Ref. no.	Type	Ref. no.				
EUR EC ¹⁾	01347	PU 10 ¹⁾	01734	PA 10 ¹⁾	01735	SU-3 10 ¹⁾	04266	SA-3 10 ¹⁾	04267	EDR ¹⁾	01437	ETR ¹⁾	01438
EUR EC ¹⁾	01347	PU 10 ¹⁾	01734	PA 10 ¹⁾	01735	SU-3 10 ¹⁾	04266	SA-3 10 ¹⁾	04267	EDR ¹⁾	01437	ETR ¹⁾	01438

1) Multiple EC fans can normally be connected, see Accessories.

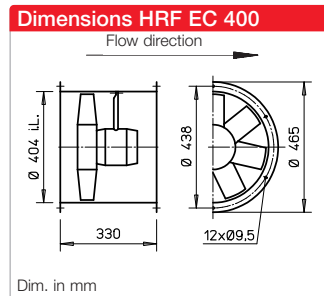
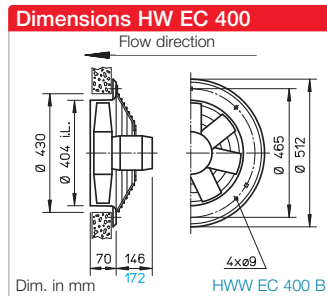
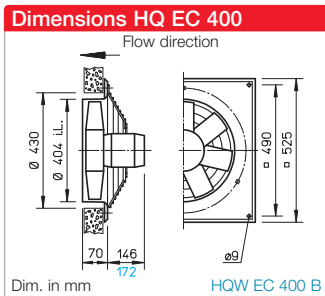
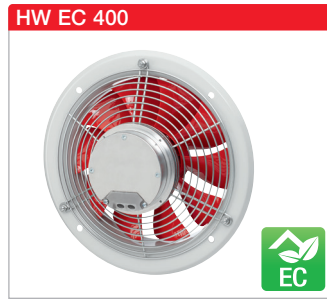

Description for all types

Casing
 Made of galvanised steel sheet, types HQ and HW have additional two layer lacquer coating in papyrus white.

Impeller
 High performance characteristics with profiled blades made of plastic, aerodynamically optimised for application, dynamically balanced.

Drive
 Energy-saving, speed-controllable external rotor EC motor in protection category IP54 with the highest level of efficiency. Maintenance-free and radio interference-free, excellent electromagnetic compatibility (EMC), ball bearing mounted.

Motor protection
 Integrated electronic temperature monitoring system for EC motor and electronics.

Electrical connection
 Standard terminal box (protection category IP54). Mounted to external cable for HQ and HW types (version "A") or on back of motor (version "B"). Mounted on outside of duct for HRF types.

Protection grille
 Made of powder-coated steel for HQ and HW in accordance with DIN EN ISO 13857.

Power control
 All types are continuously controllable via internal (delivery) or external speed potentiometer. Control is also possible via three level switch or continuously variable via universal control system or electronic differential pressure/temperature controller. See type table. Performance levels are shown on the performance curve as examples.

Installation
 Installation possible in any position.

Noise levels
 The total level and range for the sound power level and sound pressure level at 4 m free field conditions are specified above the performance diagram for the average operating point on the inlet/outlet side. The total sound pressure level at 4 m (free field conditions) is also specified in the type table, as well as the table below the performance diagram for various voltages. See page 14 f for noise emissions and room acoustics.

Speed	Flow rate-free-blowing	Power consump.	Current consump.	Sound pressure	Wiring diagram	Max. air flow temperature	Wgt net	Design type					
								HQ EC incl. protection grille	Ref. no.	HW EC incl. protection grille	Ref. no.	HRF EC	Ref. no.
min ⁻¹	V m ³ /h	kW	A	dB(A) in 4m	No.	+°C	ca. kg						
Alternating current, 1~, 230 Volt, 50/60 Hz, EC motor, protection category IP54													
1700	4790	0.32	1.40	59	1047	40	13.4	HQW EC 400 A	04922	HWW EC 400 A	04923	HRFW EC 400 A	04924
2150	5850	0.65	3.10	65	1201	40	15.4	HQW EC 400 B	04925	HWW EC 400 B	04926	HRFW EC 400 B	04927

Performance curves HQ EC / HW EC / HRF EC 400 A

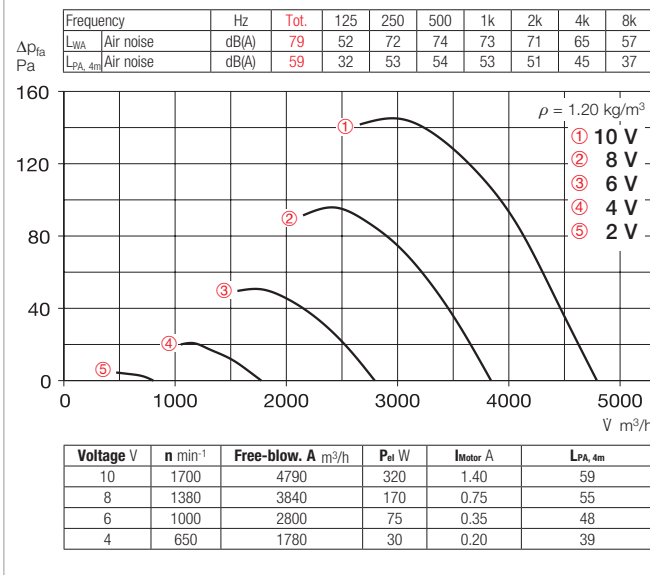

Performance curves HQ EC / HW EC / HRF EC 400 B

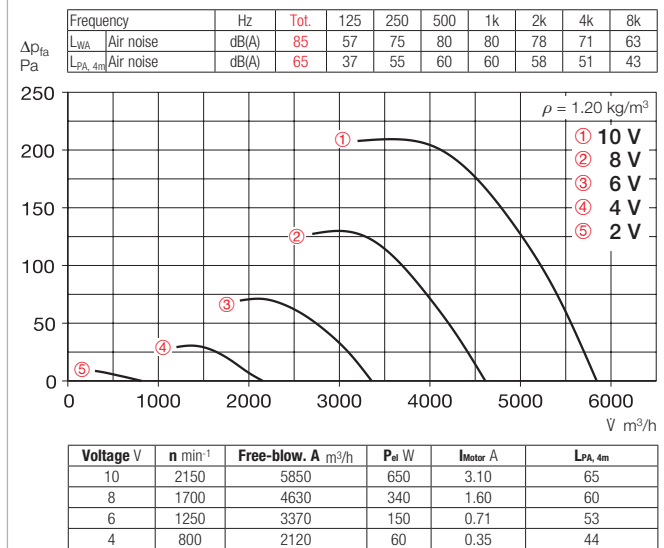

Accessories for HRF EC 400 Description see page 276 ff.

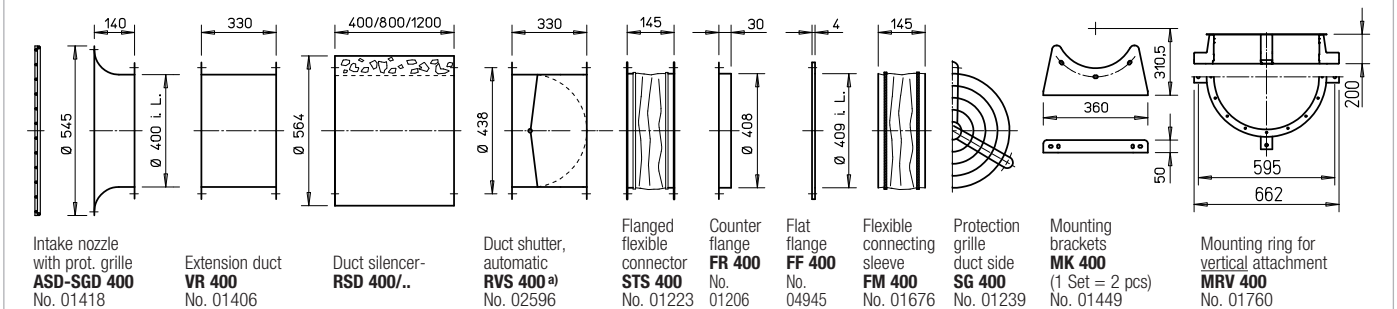

a) Shutter, motorised see Accessories product pages.

References	Page
Techn. description	180
Selection table	181
Planning information	14 ff.

Special design
Different voltage, air flow direction, higher air flow temperature, acid protection upon request.

The technical information on p.19 ff. must be observed.

Other accessories	Page
Filters and silencers	481 ff.
Shutters and ventilation grilles	561 ff.
Universal control system, electronic controller, Speed potentiometer	613 ff.

Universal control system		Speed potentiometer		Three level speed switch		Electronic pressure difference controller/ actuator		Electronic temperature controller/actuator					
Type	Ref. no.	Type	Ref. no.	Type	Ref. no.	Type	Ref. no.	Type	Ref. no.				
EUR EC ¹⁾	01347	PU 10 ¹⁾	01734	PA 10 ¹⁾	01735	SU-3 10 ¹⁾	04266	SA-3 10 ¹⁾	04267	EDR ¹⁾	01437	ETR ¹⁾	01438
EUR EC ¹⁾	01347	PU 10 ¹⁾	01734	PA 10 ¹⁾	01735	SU-3 10 ¹⁾	04266	SA-3 10 ¹⁾	04267	EDR ¹⁾	01437	ETR ¹⁾	01438

1) Multiple EC fans can normally be connected, see Accessories.

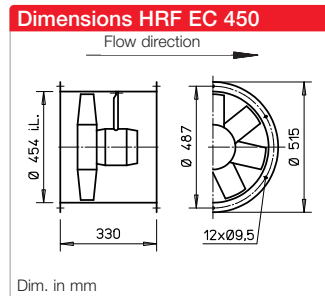
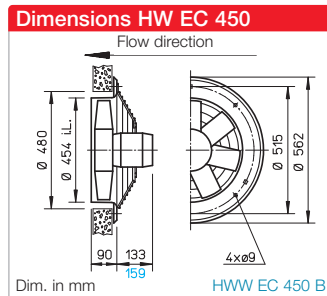
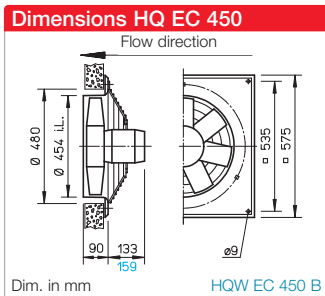

Description for all types

■ Casing
 Made of galvanised steel sheet, types HQ and HW have additional two layer lacquer coating in papyrus white.

■ Impeller
 High performance characteristics with profiled blades made of plastic, aerodynamically optimised for application, dynamically balanced.

■ Drive
 Energy-saving, speed-control-able external rotor EC motor in protection category IP54 with the highest level of efficiency. Maintenance-free and radio interference-free, excellent electromagnetic compatibility (EMC), ball bearing mounted.

■ Motor protection
 Integrated electronic temperature monitoring system for EC motor and electronics.

■ Electrical connection
 Standard terminal box (protection category IP54). Mounted to external cable for HQ and HW types (version "A") or on back of motor (version "B"). Mounted on outside of duct for HRF types.

■ Protection grille
 Made of powder-coated steel for HQ and HW in accordance with DIN EN ISO 13857.

■ Power control
 All types are continuously controllable via internal (delivery) or external speed potentiometer. Control is also possible via three level switch or continuously variable via universal control system or electronic differential pressure/temperature controller. See type table. Performance levels are shown on the performance curve as examples.

■ Installation
 Installation possible in any position.

■ Noise levels
 The total level and range for the sound power level and sound pressure level at 4 m free field conditions are specified above the performance diagram for the average operating point on the inlet/outlet side. The total sound pressure level at 4 m (free field conditions) is also specified in the type table, as well as the table below the performance diagram for various voltages. See page 14 f for noise emissions and room acoustics.

Speed	Flow rate-free-blowing	Power consump.	Current consump.	Sound pressure	Wiring diagram	Max. air flow temperature	Wgt net	Design type					
								HQ EC incl. protection grille	Ref. no.	HW EC incl. protection grille	Ref. no.	HRF EC	Ref. no.
min ⁻¹	V m ³ /h	kW	A	dB(A) at 4m	No.	+°C	ca. kg						
Alternating current, 1~, 230 Volt, 50/60 Hz, EC motor, protection category IP54													
1320	5460	0.29	1.30	55	1047	40	14.5	HQW EC 450 A	04928	HWW EC 450 A	04929	HRFW EC 450 A	04930
1835	7640	0.82	3.80	64	1201	40	16.5	HQW EC 450 B	04931	HWW EC 450 B	04932	HRFW EC 450 B	04933

Performance curves HQ EC / HW EC / HRF EC 450 A

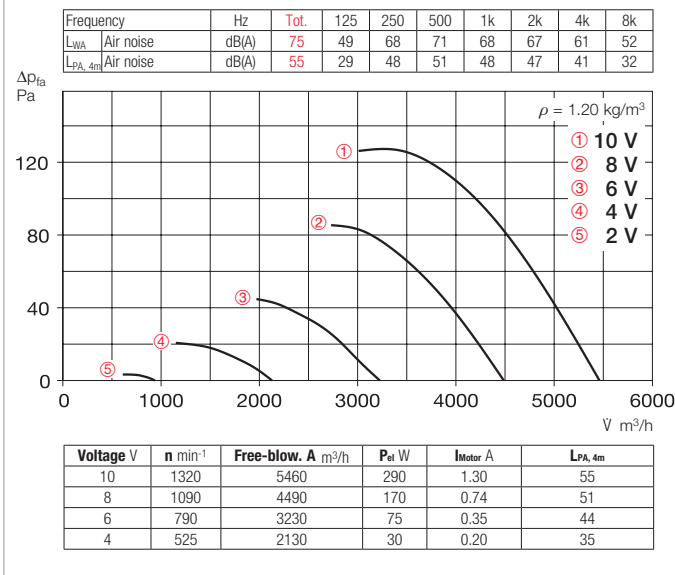

Performance curves HQ EC / HW EC / HRF EC 450 B

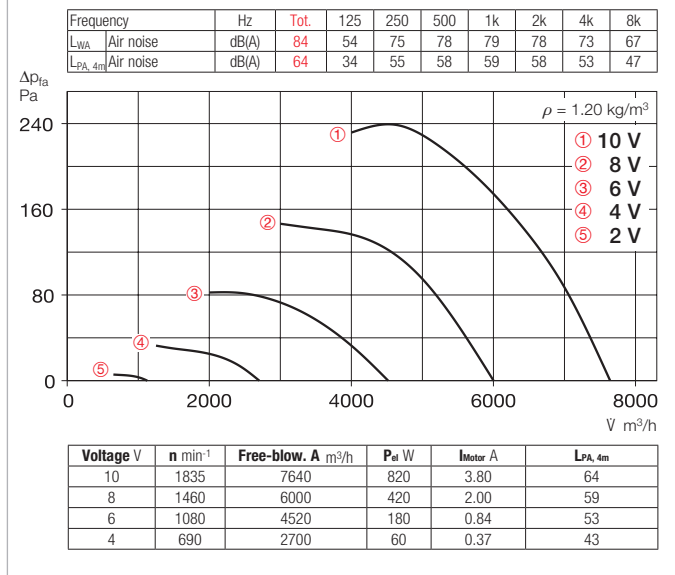

Accessories for HRF EC 450 Description see page 276 ff.

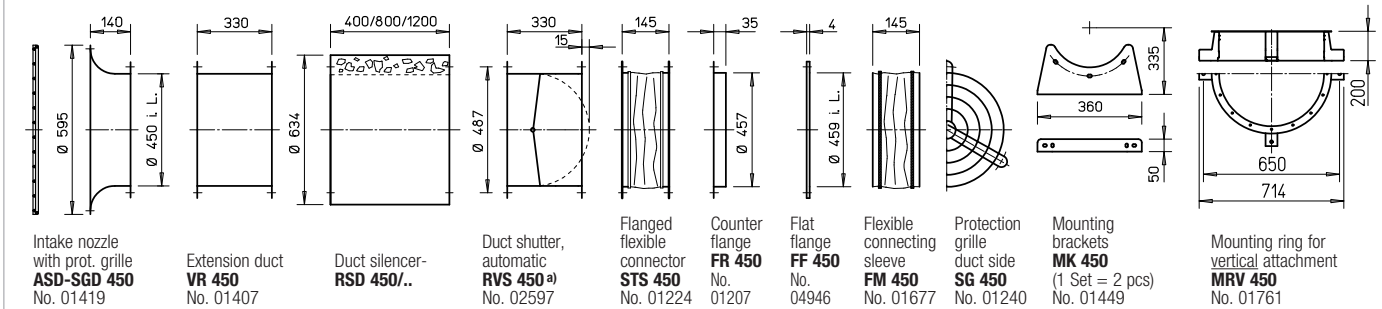

a) Shutter, motorised see Accessories product pages.

References	Page	Other accessories	Page
Techn. description	180	Filters and silencers	481 ff.
Selection table	181	Shutters and ventilation grilles	561 ff.
Planning information	14 ff.	Universal control system, electronic controller, Speed potentiometer	613 ff.

Special design
Different voltage, air flow direction, higher air flow temperature, acid protection upon request.

The technical information on p.19 ff. must be observed.

Universal control system		Speed potentiometer		Three level speed switch		Electronic pressure difference controller/ actuator		Electronic temperature controller/actuator					
Type	Ref. no.	Type	Ref. no.	Type	Ref. no.	Type	Ref. no.	Type	Ref. no.				
EUR EC ¹⁾	01347	PU 10 ¹⁾	01734	PA 10 ¹⁾	01735	SU-3 10 ¹⁾	04266	SA-3 10 ¹⁾	04267	EDR ¹⁾	01437	ETR ¹⁾	01438
EUR EC ¹⁾	01347	PU 10 ¹⁾	01734	PA 10 ¹⁾	01735	SU-3 10 ¹⁾	04266	SA-3 10 ¹⁾	04267	EDR ¹⁾	01437	ETR ¹⁾	01438

1) Multiple EC fans can normally be connected, see Accessories.

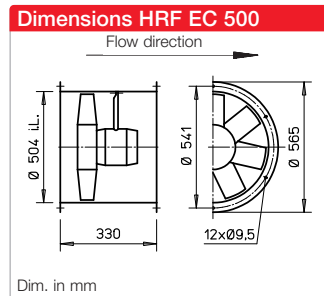
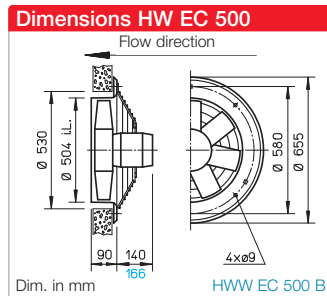
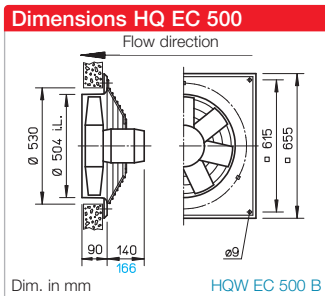

Description for all types

Casing
 Made of galvanised steel sheet, types HQ and HW have additional two layer lacquer coating in papyrus white.

Impeller
 High performance characteristics with profiled blades made of plastic, aerodynamically optimised for application, dynamically balanced.

Drive
 Energy-saving, speed-controllable external rotor EC motor in protection category IP54 with the highest level of efficiency. Maintenance-free and radio interference-free, excellent electromagnetic compatibility (EMC), ball bearing mounted.

Motor protection
 Integrated electronic temperature monitoring system for EC motor and electronics.

Electrical connection
 Standard terminal box (protection category IP54). Mounted to external cable for HQ and HW types (version "A") or on back of motor (version "B"). Mounted on outside of duct for HRF types.

Protection grille
 Made of powder-coated steel for HQ and HW in accordance with DIN EN ISO 13857.

Power control
 All types are continuously controllable via internal (delivery) or external speed potentiometer. Control is also possible via three level switch or continuously variable via universal control system or electronic differential pressure/temperature controller. See type table. Performance levels are shown on the performance curve as examples.

Installation
 Installation possible in any position.

Noise levels
 The total level and range for the sound power level and sound pressure level at 4 m free field conditions are specified above the performance diagram for the average operating point on the inlet/outlet side. The total sound pressure level at 4 m (free field conditions) is also specified in the type table, as well as the table below the performance diagram for various voltages. See page 14 f for noise emissions and room acoustics.

Speed min ⁻¹	Flow rate-free-blowing V m ³ /h	Power consump. kW	Current consump. A	Sound pressure dB(A) at 4m	Wiring diagram No.	Max. air flow temperature +°C	Wgt net ca. kg	Design type					
								HQ EC incl. protection grille	Ref. no.	HW EC incl. protection grille	Ref. no.	HRF EC	Ref. no.
Alternating current, 1~, 230 Volt, 50/60 Hz, EC motor, protection category IP54													
1090	6320	0.29	1.30	54	1047	40	15.7	HQW EC 500 A	04934	HWW EC 500 A	04935	HRFW EC 500 A	04936
1450	8300	0.67	3.00	62	1201	40	17.7	HQW EC 500 B	04937	HWW EC 500 B	04938	HRFW EC 500 B	04939

Performance curves HQ EC / HW EC / HRF EC 500 A

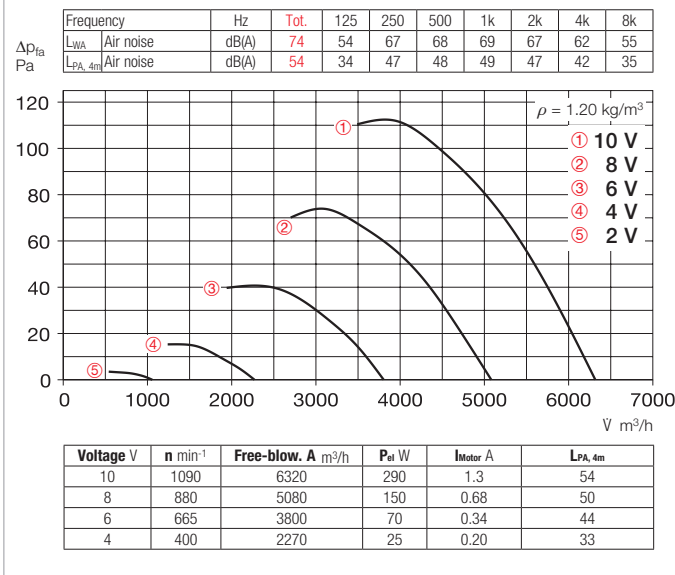

Performance curves HQ EC / HW EC / HRF EC 500 B

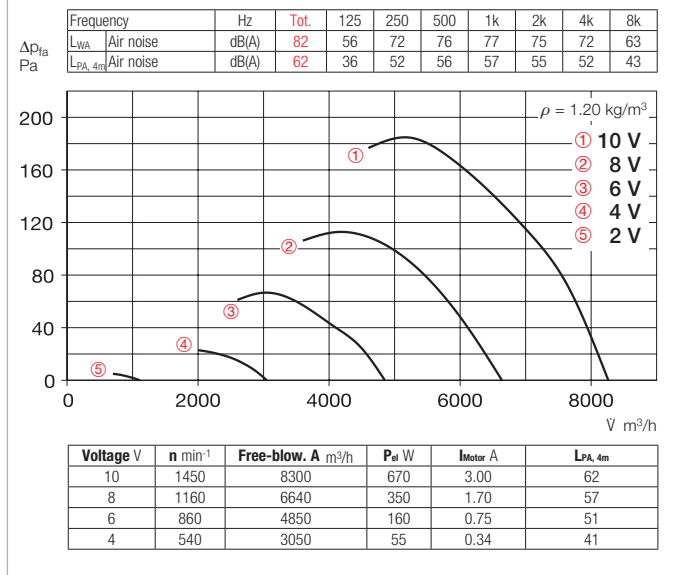

Accessories for HRF EC 500 Description see page 276 ff.

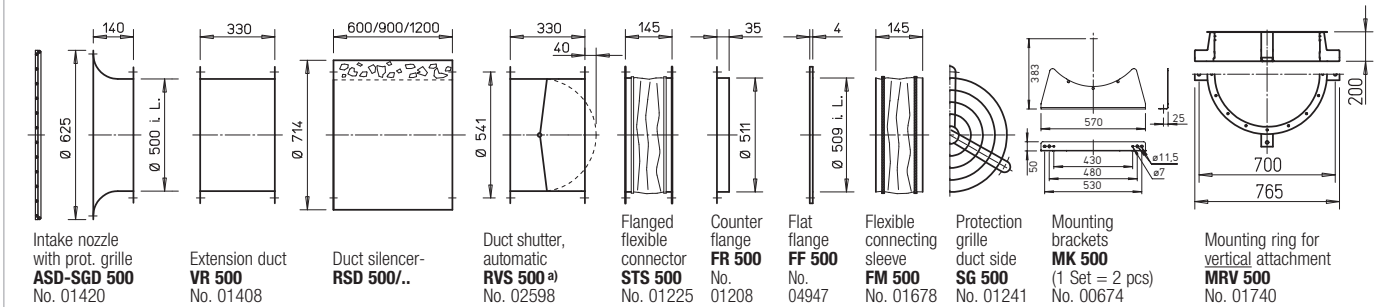

^{a)} Shutter, motorised see Accessories product pages.

References	Page	Other accessories	Page
Techn. description	180	Filters and silencers	481 ff.
Selection table	181	Shutters and ventilation grilles	561 ff.
Planning information	14 ff.	Universal control system, electronic controller, Speed potentiometer	613 ff.

Special design
Different voltage, air flow direction, higher air flow temperature, acid protection upon request.

The technical information on p.19 ff. must be observed.

Universal control system		Speed potentiometer		Three level speed switch		Electronic pressure difference controller/ actuator		Electronic temperature controller/actuator	
Type	Ref. no.	Type	Ref. no.	Type	Ref. no.	Type	Ref. no.	Type	Ref. no.
EUR EC ¹⁾	01347	PU 10 ¹⁾	01734	PA 10 ¹⁾	01735	SU-3 10 ¹⁾	04266	SA-3 10 ¹⁾	04267
EUR EC ¹⁾	01347	PU 10 ¹⁾	01734	PA 10 ¹⁾	01735	SU-3 10 ¹⁾	04266	SA-3 10 ¹⁾	04267
								EDR ¹⁾	01437
								ETR ¹⁾	01438

¹⁾ Multiple EC fans can normally be connected, see Accessories.

HRF EC 560

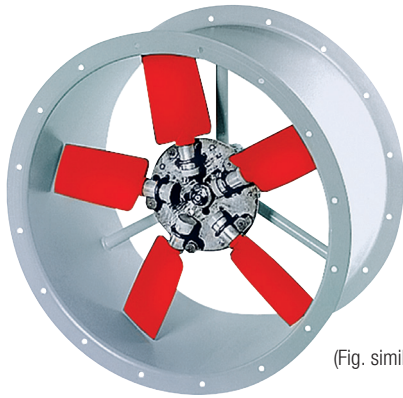

(Fig. similar)



Dimensions HRF EC 560

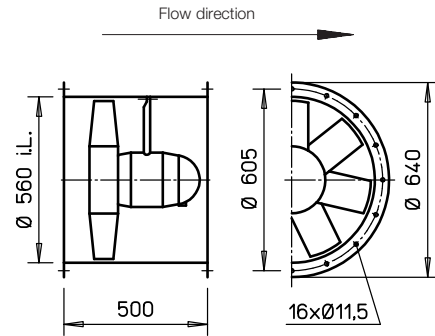

Dim. in mm

■ Description

High performance axial EC fan in pipe sleeve, with double-sided flanges for direct intermediate setting in pipelines. Flange in accordance with DIN 24155, p. 3.

■ Casing

Made of galvanised steel sheet, additional terminal box (IP54) on outside of duct.

■ Impeller

High performance characteristics with profiled blades made of plastic, aerodynamically optimised for application, dynamically balanced.

■ Drive

Energy-saving, speed-controllable external rotor EC motor in protection category IP54 with the highest level of efficiency. Maintenance-free and radio interference-free, excellent electromagnetic compatibility (EMC), ball bearing mounted.

■ Motor protection

Integrated electronic temperature monitoring system for EC motor and electronics.

■ Electrical connection

Standard terminal box (protection category IP54) on back of motor, additional terminal box on outside of duct.

■ Power control

All types are continuously controllable via internal (delivery) or external speed potentiometer. Control is also possible via three level switch or continuously variable via universal control system or electronic differential pressure/temperature controller. See type table.

■ Installation

Installation possible in any position.

■ Noise levels

The total level and range for the sound power level and sound pressure level at 4 m free field conditions are specified above the performance diagram for the average operating point on the inlet/outlet side. The total sound pressure level at 4 m (free field conditions) is also specified in the type table, as well as the table below the performance diagram for various voltages. See page 14 f for noise emissions and room acoustics.

Speed	Flow rate-free-blowing	Power consump.	Current consum.	Sound pressure	Wiring diagram	Max. air flow temperature	Wgt net	Design type	
								HRF EC	Ref. no.
min ⁻¹	V m ³ /h	kW	A	dB(A) at 4m	No.	+°C	ca. kg		
Alternating current, 1~, 230 Volt, 50/60 Hz, EC motor, protection category IP54									
1200	9740	0.56	2.45	55	1201	40	35	HRFW EC 560	04874

Performance curves HRF EC 560 A

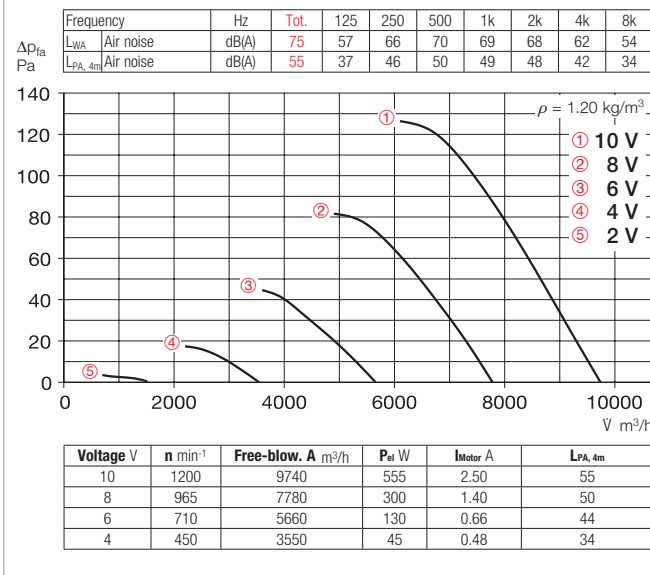

Accessories for HRF EC 560 Description see page 276 ff.

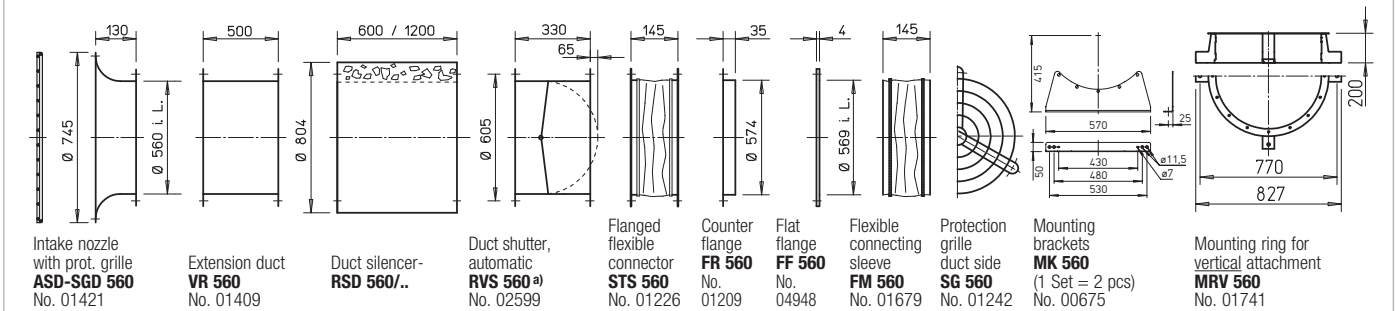

^{a)} Shutter, motorised see Accessories product pages.

References	Page	Other accessories	Page
Techn. description	180	Filters and silencers	481 ff.
Selection table	181	Shutters and ventilation grilles	561 ff.
Planning information	14 ff.	Universal control system, electronic controller, Speed potentiometer	613 ff.
Special design Different voltage, air flow direction, higher air flow temperature, acid protection upon request.			
The technical information on p.19 ff. must be observed.			

Universal control system		Speed potentiometer		Three level speed switch		Electronic pressure difference controller/ actuator		Electronic temperature controller/actuator					
Type	Ref. no.	Type	Ref. no.	Type	Ref. no.	Type	Ref. no.	Type	Ref. no.				
EUR EC ¹⁾	01347	PU 10 ¹⁾	01734	PA 10 ¹⁾	01735	SU-3 10 ¹⁾	04266	SA-3 10 ¹⁾	04267	EDR ¹⁾	01437	ETR ¹⁾	01438

¹⁾ Multiple EC fans can normally be connected, see Accessories.

HRF EC 630

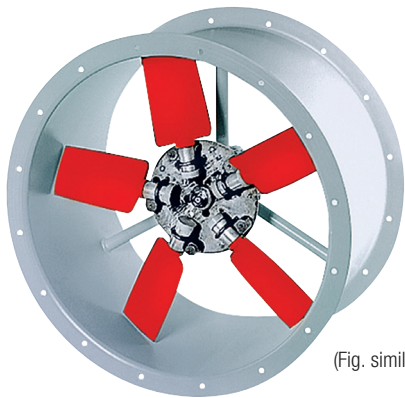

(Fig. similar)



Dimensions HRF EC 630

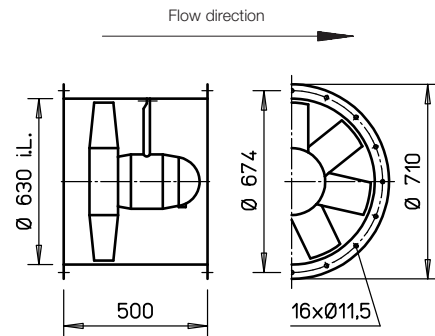

Dim. in mm

■ Description

High performance axial EC fan in pipe sleeve, with double-sided flanges for direct intermediate setting in pipelines. Flange in accordance with DIN 24155, p. 3.

■ Casing

Made of galvanised steel sheet, additional terminal box (IP54) on outside of duct.

■ Impeller

High performance characteristics with profiled blades made of plastic, aerodynamically optimised for application, dynamically balanced.

■ Drive

Energy-saving, speed-controllable external rotor EC motor in protection category IP54 with the highest level of efficiency. Maintenance-free and radio interference-free, excellent electromagnetic compatibility (EMC), ball bearing mounted.

■ Motor protection

Integrated electronic temperature monitoring system for EC motor and electronics.

■ Electrical connection

Standard terminal box (protection category IP54) on back of motor, additional terminal box on outside of duct.

■ Power control

All types are continuously controllable via internal (delivery) or external speed potentiometer. Control is also possible via three level switch or continuously variable via universal control system or electronic differential pressure/temperature controller. See type table.

■ Installation

Installation possible in any position.

■ Noise levels

The total level and range for the sound power level and sound pressure level at 4 m free field conditions are specified above the performance diagram for the average operating point on the inlet/outlet side. The total sound pressure level at 4 m (free field conditions) is also specified in the type table, as well as the table below the performance diagram for various voltages. See page 14 f for noise emissions and room acoustics.

Speed	Flow rate-free-blowing	Power consump.	Current consum.	Sound pressure	Wiring diagram	Max. air flow temperature	Wgt net	Design type	
								HRF EC	Ref. no.
min ⁻¹	V m ³ /h	kW	A	dB(A) at 4m	No.	+°C	ca. kg		
Alternating current, 1~, 230 Volt, 50/60 Hz, EC motor, protection category IP54									
960	10330	0.45	2.20	54	1201	40	37	HRFW EC 630	04875

Performance curves HRF EC 630 A

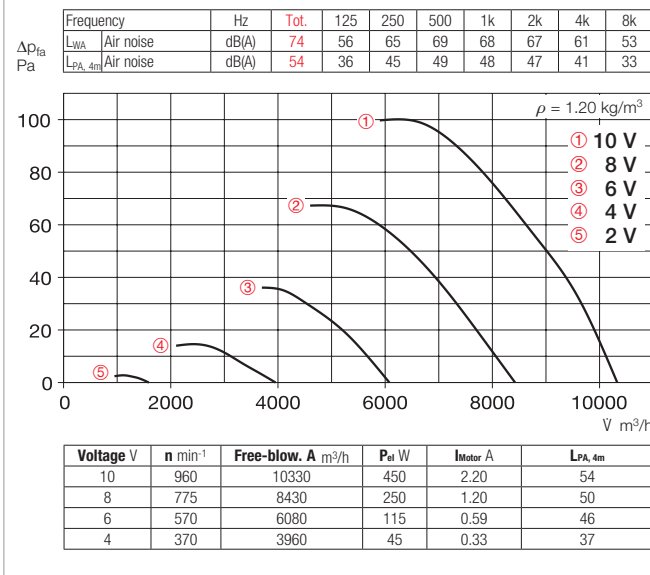

Accessories for HRF EC 630 Description see page 276 ff.

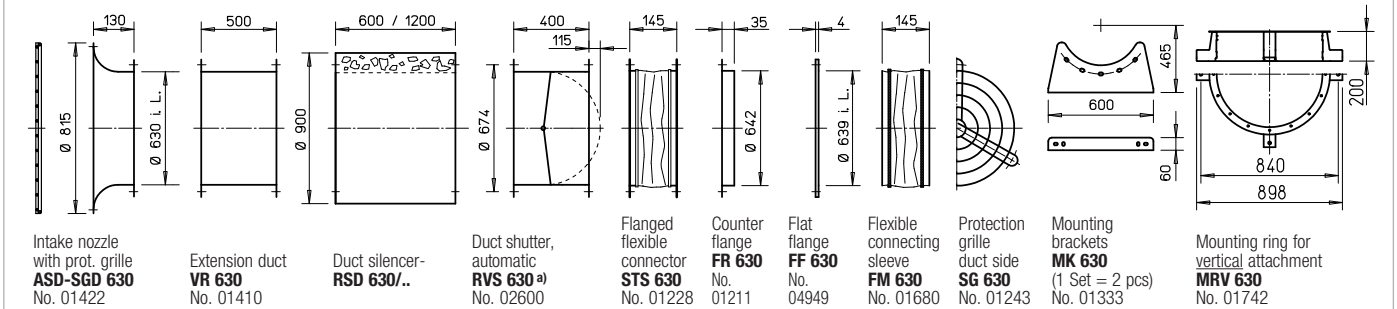

^{a)} Shutter, motorised see Accessories product pages.

References	Page	Other accessories	Page
Techn. description	180	Filters and silencers	481 ff.
Selection table	181	Shutters and ventilation grilles	561 ff.
Planning information	14 ff.	Universal control system, electronic controller, Speed potentiometer	613 ff.

Special design
Different voltage, air flow direction, higher air flow temperature, acid protection upon request.

The technical information on p.19 ff. must be observed.

Universal control system		Speed potentiometer		Three level speed switch		Electronic pressure difference controller/ actuator		Electronic temperature controller/actuator					
Type	Ref. no.	Type	Ref. no.	Type	Ref. no.	Type	Ref. no.	Type	Ref. no.				
EUR EC ¹⁾	01347	PU 10 ¹⁾	01734	PA 10 ¹⁾	01735	SU-3 10 ¹⁾	04266	SA-3 10 ¹⁾	04267	EDR ¹⁾	01437	ETR ¹⁾	01438

¹⁾ Multiple EC fans can normally be connected, see Accessories.

HRF EC 710

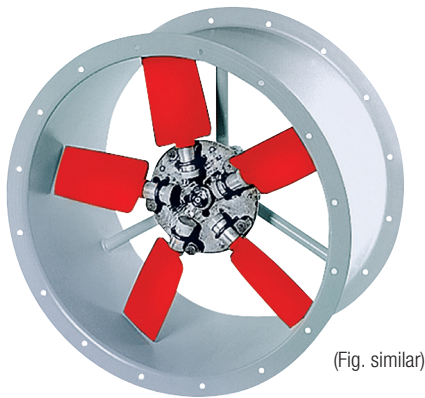

(Fig. similar)



Dimensions HRF EC 710

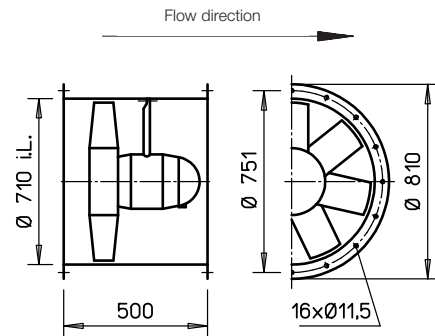

Dim. in mm

■ Description

High performance axial EC fan in pipe sleeve, with double-sided flanges for direct intermediate setting in pipelines. Flange in accordance with DIN 24155, p. 3.

■ Casing

Made of galvanised steel sheet, additional terminal box (IP54) on outside of duct.

■ Impeller

High performance characteristics with profiled blades made of plastic, aerodynamically optimised for application, dynamically balanced.

■ Drive

Energy-saving, speed-controllable external rotor EC motor in protection category IP54 with the highest level of efficiency. Maintenance-free and radio interference-free, excellent electromagnetic compatibility (EMC), ball bearing mounted.

■ Motor protection

Integrated electronic temperature monitoring system for EC motor and electronics.

■ Electrical connection

Standard terminal box (protection category IP54) on back of motor, additional terminal box on outside of duct.

■ Power control

All types are continuously controllable via internal (delivery) or external speed potentiometer. Control is also possible via three level switch or continuously variable via universal control system or electronic differential pressure/temperature controller. See type table.

■ Installation

Installation possible in any position.

■ Noise levels

The total level and range for the sound power level and sound pressure level at 4 m free field conditions are specified above the performance diagram for the average operating point on the inlet/outlet side. The total sound pressure level at 4 m (free field conditions) is also specified in the type table, as well as the table below the performance diagram for various voltages. See page 14 f for noise emissions and room acoustics.

Speed	Flow rate-free-blowing	Power consump.	Current consum.	Sound pressure	Wiring diagram	Max. air flow temperature	Wgt net	Design type	
								HRF EC	Ref. no.
min ⁻¹	V m ³ /h	kW	A	dB(A) at 4m	No.	+°C	ca. kg		
Three-phase current, 3~, 400 Volt, 50/60 Hz, EC motor, protection category IP54									
1100	19400	1.32	2.10	61	1201	40	40	HRFD EC 710	04876

Performance curves HRF EC 710 A

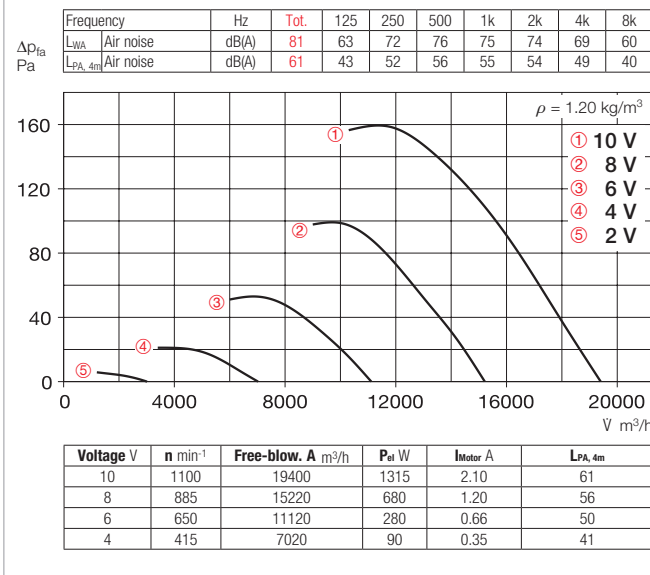

Accessories for HRF EC 710 Description see page 276 ff.

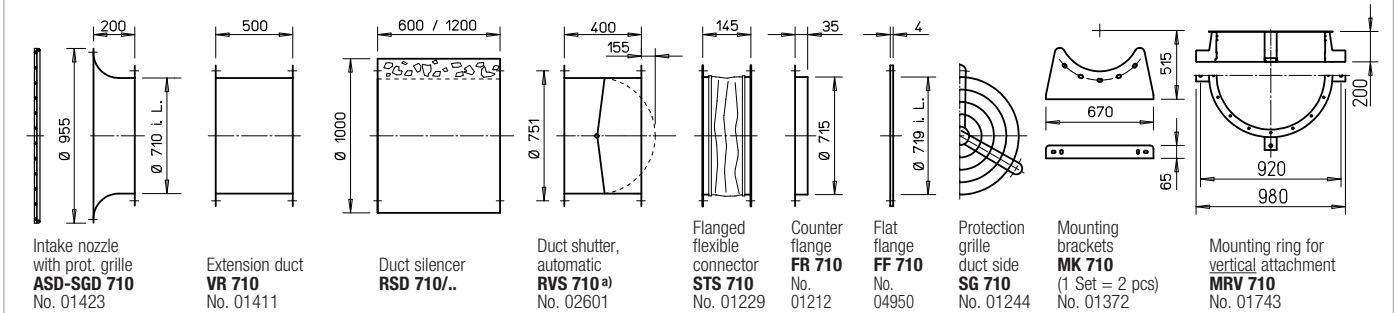

^{a)} Shutter, motorised see Accessories product pages.

References	Page	Other accessories	Page
Techn. description	180	Filters and silencers	481 ff.
Selection table	181	Shutters and ventilation grilles	561 ff.
Planning information	14 ff.	Universal control system, electronic controller, Speed potentiometer	613 ff.
Special design Different voltage, air flow direction, higher air flow temperature, acid protection upon request.			
The technical information on p.19 ff. must be observed.			

Universal control system		Speed potentiometer		Three level speed switch		Electronic pressure difference controller/actuator		Electronic temperature controller/actuator					
Type	Ref. no.	Type	Ref. no.	Type	Ref. no.	Type	Ref. no.	Type	Ref. no.				
EUR EC ¹⁾	01347	PU 10 ¹⁾	01734	PA 10 ¹⁾	01735	SU-3 10 ¹⁾	04266	SA-3 10 ¹⁾	04267	EDR ¹⁾	01437	ETR ¹⁾	01438

¹⁾ Multiple EC fans can normally be connected, see Accessories.

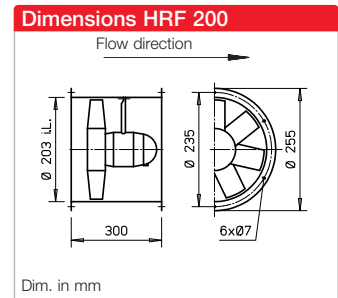
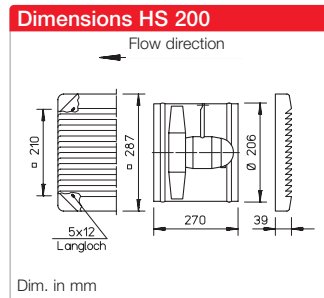
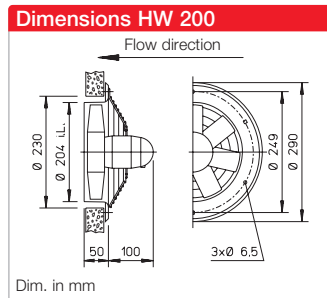
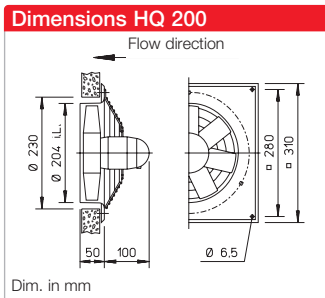

Description for all types

- **Casing**
 Made of galvanised steel sheet, types HQ and HW have additional two layer lacquer coating in papyrus white.
- **Impeller**
 High performance characteristics with profiled blades made of plastic, dynamically balanced.
- **Drive**
 Closed casing made of die-cast aluminium. Protection category IP54, ball bearing mounted. Maintenance-free and radio interference-free. Winding with moisture proof coating. See type table for max. air flow temperature.

- **Motor protection**
 Through built-in thermal contacts wired in series with the winding, automatic deactivation and reactivation after cool down.
- **Electrical connection**
 Standard terminal box (IP54) on back of motor. Additionally on outside of duct for HRF types.
- **Protection grille**
 Made of powder-coated steel for HQ and HW, and plastic for HS. In accordance with DIN EN ISO 13857.
- **Power control**
 All types can be controlled through voltage reduction (electronic or via transformer). The flow rates are shown in the performance diagram.

- **Reverse operation**
 All types are reversible using a DSEL switch. Performance reduction of approx. 1/3 in abnormal flow direction.
- **Installation**
 Installation possible in any position, but be aware of any condensate drain holes depending on usage.
- **Noise levels**
 See performance diagram. The sound power and sound pressure at 1 m distance under free field conditions are specified for the average operating point on the inlet/outlet side. See page 14 f for noise emissions and room acoustics.

Reference	Page
Techn. description	180
Selection table	181
Planning information	14 ff.
Special design	
Different voltage, protection category, air flow direction, higher air flow temperature, acid protection and impeller in other materials upon request.	
The technical information on p. 19 ff. must be observed.	

Speed min ⁻¹	Flow rate free-blowing V m ³ /h	Power consump. W	Current consump.		Wiring dia- gram No.	Max. air flow temp.		Weight net aprx. kg	Design type							
			at rated voltage A	max. with control A		at rated voltage + °C	with control + °C		HQ incl. Ref. no. protection grille		HW incl. Ref. no. protection grille		HS incl. Ref. no. protection grille		HRF Ref. no.	
Single-phase alternating current. 230 Volt, 50 Hz, Capacitor motor, protection category IP54																
1360	520	25	0.11	0.11	439 ¹⁾	60	40	3.8	HQW 200/4	07537	HW 200/4	07538	HSW 200/4	07502	HRFW 200/4¹⁾	07540
2250	930	66	0.26	0.31	439 ¹⁾	40	40	2.7	HQW 200/2	00960	–	–	HSW 200/2	07503	HRFW 200/2¹⁾	00199

¹⁾ Type HRFW: Connection according to wiring diagram no. 962.

Performance curves 200/2

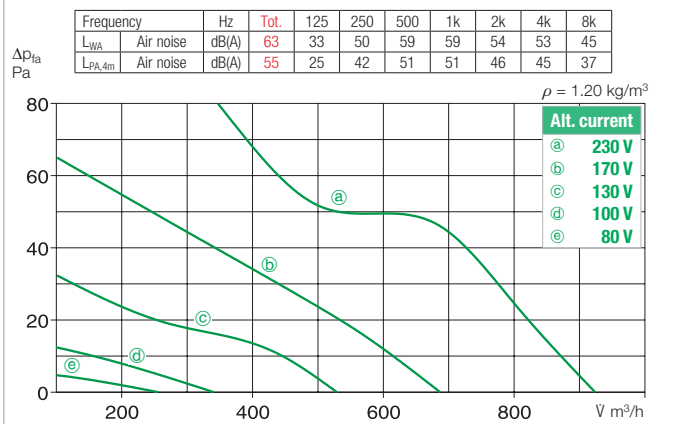

Performance curves 200/4

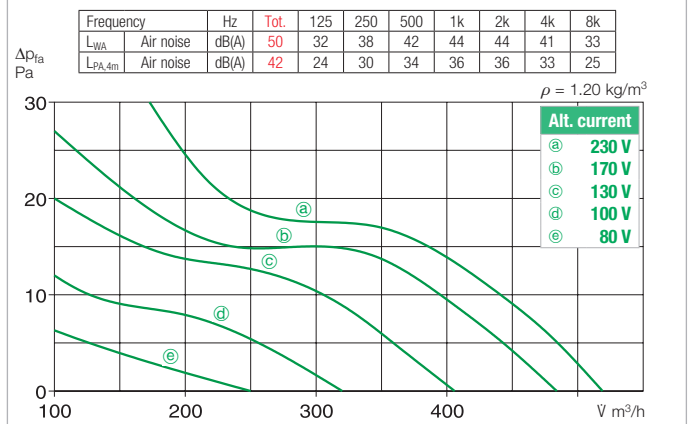

Accessories for HRF 200 Description see page 276 ff.

<p>Intake nozzle ASD 200 No. 01388</p>	<p>Flanged flexible connector STS 200 No. 01219</p>	<p>Counter flange FR 200 No. 01202</p>	<p>Flexible connecting sleeve FM 200 No. 01670</p>	<p>Protection grille duct side SG 200 No. 01216</p>	<p>2 mounting brackets 1 x MK 200 (= 2 pcs) No. 01446</p>	<p>4 vibration dampers for tensile load 1 x SDZ 1 (= 4 Pc) No.01454 4 vibration dampers for compression load 1 x SDD 1 (= 4 Pc) No.01452</p>
---	--	---	---	--	--	--

Type	Ref. no.	Type	Ref. no.	Type	Ref. no.	Type	Ref. no.
Transformer speed controller 5-step		Electronic speed controller, continuously variable flush-m./surface-m.		Reverser switch		Electronic speed controller with reverser switch	
TSW 0.3	03608	ESU 1/ESA 1	00236/00238	DSEL 2	01306	BSX	00240
TSW 0.3	03608	ESU 1/ESA 1	00236/00238	DSEL 2	01306	BSX	00240

Other accessories Page

Extension sleeve for HS VH 200 Ref. no. 01349
Cylindrical pipe section, galvanised steel, 15 cm long.

Filters and silencers 481 ff.
shutters and ventilation grilles 561 ff.
Speed controllers, controllers and switches 599 ff.

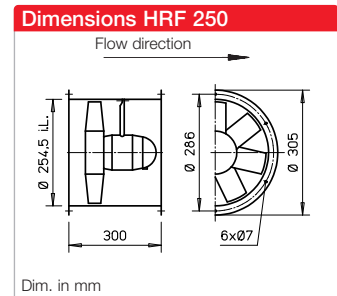
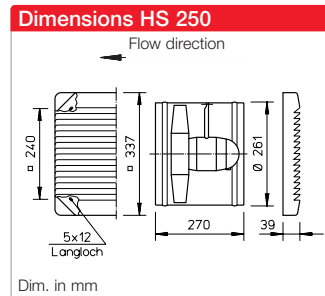
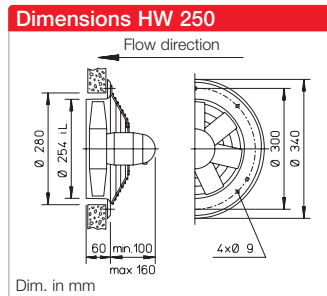
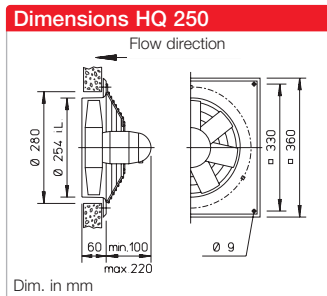

Description for all types

- Casing**
 Made of galvanised steel sheet, types HQ and HW have additional two layer lacquer coating in papyrus white. Explosion-proof types have no lacquer coating.
- Impeller**
 High performance characteristics with profiled blades made of plastic, dynamically balanced. Different for explosion-proof types.
- Drive**
 Closed die-cast aluminium casing. Protection category IP55 or IP54. Ball bearing mounted. Maintenance-free and radio interference-free. Winding with moisture proof coating. See type table for max. air flow temperature. Different for explosion-proof types.

- Motor protection**
 All types (except for 3~ explosion-proof) are equipped 180th thermal contacts. These should be wired with the motor protection circuit breaker (see type table) for effective motor protection. For types H..W 250/6, H..W 250/4 and all 1~ explosion-proof fans, the thermal contacts are wired in series with the winding, automatic deactivation and reactivation after cool down.
- Electrical connection**
 Standard terminal box (IP54/55) on back of motor. Additionally on outside of duct for HRF types. Different for explosion-proof types.
- Protection grille**
 Made of powder-coated steel for HQ/HW (HQ Ex galvanised), and plastic for HS. In accordance with DIN EN ISO 13857.

- Power control**
 The voltage-controllable types are identified in the "Current consumption max. with control" column with a value which must be observed when determining the controller (see speed controller column). Possible assignments of frequency inverters to fans are shown in the type table. The flow rates are shown in the performance diagram.
- Reverse operation**
 All types are reversible using a reverser switch. Performance reduction of approx. 1/3 in abnormal flow direction.
- Installation**
 Installation possible in any position, but be aware of any condensate drain holes depending on usage.

- Dimensions**
 Pole-changeable and explosion-proof types may differ from the above information.
- Noise levels**
 See performance diagram. The sound power and sound pressure at 4 m distance under free field conditions are specified for the average operating point on the inlet/outlet side. See page 14 f for noise emissions and room acoustics. Different for explosion-proof types.

Reference	Page
Techn. description	180
Selection table	181
Planning information	14 ff.

Speed	Flow rate free-blowing	Power consump.	Current consump.		Wiring diagram	Max. air flow temp.		Weight net appr.	Design type							
			at rated voltage	max. with control		at rated voltage	with control		HQ incl. protection grille	Ref. no.	HW incl. protection grille	Ref. no.	HS incl. protection grille	Ref. no.	HRF	Ref. no.
min ⁻¹	V m ³ /h	W	A	A	No.	+ °C	+ °C	kg								
Single-phase alternating current, 230 Volt, 50 Hz, Capacitor motor, protection category IP54/55																
930	660	35	0.20	0.22	317	60	40	6.5	HQW 250/6	01102	—	—	HSW 250/6	00139	—	—
1300	930	36	0.15	0.15	439 ¹⁾	60	40	7.5	HQW 250/4 ¹⁾	01103	HWW 250/4 ¹⁾	01001	HSW 250/4 ¹⁾	00140	HRFW 250/4 ¹⁾²⁾	00200
2710	2070	187	0.81	0.9	317 ¹⁾	60	40	6.5	HQW 250/2	01104	HWW 250/2	01002	HSW 250/2	00141	HRFW 250/2 ³⁾	00201
Three-phase current, 400 Volt, 50 Hz, Squirrel-cage rotor, protection category IP55																
980	700	61	0.27	0.33	469	60	40	6.5	HQD 250/6	01114	—	—	—	—	—	—
1390	950	55	0.15	0.15	469	60	40	6.5	HQD 250/4 ¹⁾	01115	HWD 250/4 ¹⁾	01016	HSD 250/4 ¹⁾	00155	HRFD 250/4 ¹⁾	00220
2550	2000	169	0.31	0.33	469	60	40	6.5	HQD 250/2	01116	HWD 250/2	01017	—	—	HRFD 250/2	00221
Pole-changeable, 2 speeds, three-phase current, Dahlander winding, 400 Volt, 50 Hz, protection category IP55																
1430/2770	1030/2110	58/212	0.16/0.43	—	472	60	—	8.5	HQD 250/4/2	01128	—	—	—	—	HRFD 250/4/2	00390
Ex Ex Explosion-proof, II 2G Ex h IIB T3 Gb, Motor Ex d, alternating current 230 Volt, 50 Hz, protection category IP55																
1400	1030	60*	0.70*	—	757	40	—	12	HQW 250/4 Ex	00438	—	—	—	—	HRFW 250/4 Ex	00437
2690	1950	180*	1.23*	—	757	40	—	13	HQW 250/2 Ex	01094	—	—	—	—	HRFW 250/2 Ex	01095
Ex Ex Explosion-proof, II 2G Ex h IIB + H₂ T3 Gb, Motor Ex e, three-phase current 400 Volt, 50 Hz, protection category IP55																
1355	1070	120*	0.37*	—	470	40	—	12	HQD 250/4 Ex	01144	—	—	—	—	HRFD 250/4 Ex	00470
2800	2070	250*	0.75*	—	470	40	—	11	HQD 250/2 Ex	01145	—	—	—	—	HRFD 250/2 Ex	00471

* Motor ratings, Ex see information on page 20. ¹⁾ Special design not possible. ²⁾ Type HRFW..4: Connection according to wiring diagram no. 962. ³⁾ Type HRFW..2: Connection according to wiring diagram no. 963.

Performance curves 250/2

Frequency		Hz	Tot.	125	250	500	1k	2k	4k	8k
L _{WA}	Air noise		75	38	53	66	68	70	69	62
L _{PA,4m}	Air noise		55	18	33	46	48	49	48	42

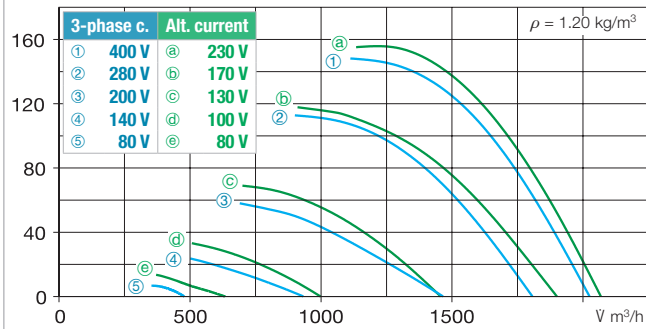

Performance curves 250/4 Alternating current

Frequency		Hz	Tot.	125	250	500	1k	2k	4k	8k
L _{WA}	Air noise		58	41	52	53	51	49	43	29
L _{PA,4m}	Air noise		38	21	32	33	31	29	23	9

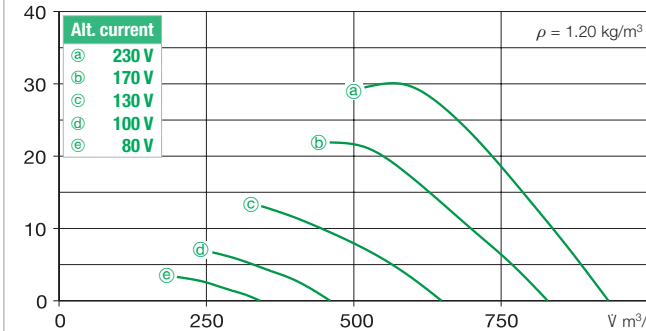

Performance curves 250/4 Three-phase current

Frequency		Hz	Tot.	125	250	500	1k	2k	4k	8k
L _{WA}	Air noise		60	34	49	53	53	54	50	38
L _{PA,4m}	Air noise		40	14	29	33	33	34	30	18

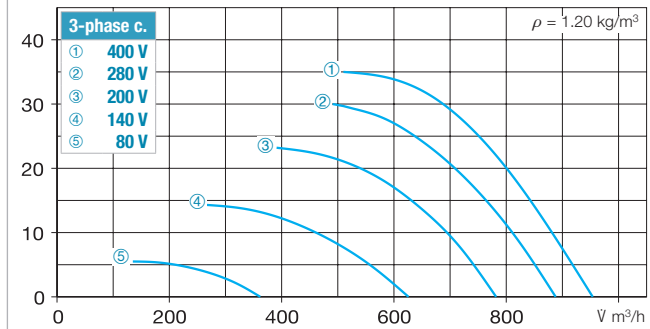

Performance curves 250/6

Frequency		Hz	Tot.	125	250	500	1k	2k	4k	8k
L _{WA}	Air noise		53	40	47	47	46	43	37	30
L _{PA,4m}	Air noise		33	20	27	27	26	23	17	10

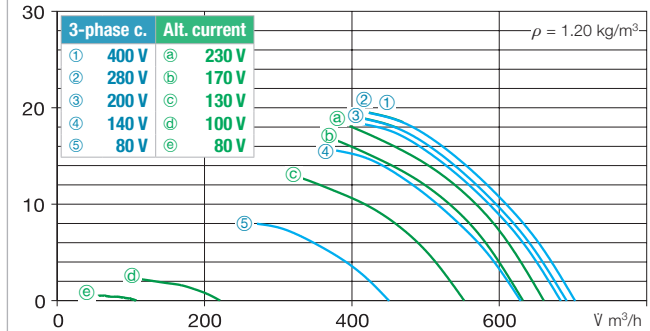

Accessories for HRF 250 Description see page 276 ff.

Intake nozzle with prot. grille ASD-SGD 250 No. 01414
 Extension duct VR 250 No. 01402
 Duct silencer RSD 250/..
 Duct shutter, automatic RVS 250^{a)} No. 02592
 Flanged flexible connector STS 250^{b)} No. 01220
 Counter flange FR 250 No. 01203
 Flat flange FF 250 No. 04941
 Flexible connecting sleeve FM 250^{b)} No. 01672
 Protection grille duct side SG 250 No. 01236
 2 mounting brackets 1 x MK 250 (= 2 pcs) No. 01447
 4 vibration dampers for tensile load 1 x SDZ 1 (= 4 Pcs) No. 01454
 4 vibration dampers for compression load 1 x SDD 1 (= 4 Pcs) No. 01452

^{a)} Shutter, motorised see Accessories product pages.

^{b)} See below for types for explosion-proof fans.

Frequency inverter with integrated sine filter		Transformer speed controller 5-step, pole changing switch		Electronic speed controller, continuously variable flush-m./surface-m.		Motor protection circuit breaker for connecting built-in thermal contacts		Reverser switch	
Type	Ref. no.	Type	Ref. no.	Type	Ref. no.	Type	Ref. no.	Type	Ref. no.
—	—	TSW 0.3	03608	ESU 1/ESA 1	00236/00238	—	—	WS	01271
—	—	TSW 0.3	03608	ESU 1/ESA 1	00236/00238	—	—	DSEL 2	01306
—	—	MWS 1.5 ⁴⁾	01947	ESU 3/ESA 3	00237/00239	—	—	WS	01271
FU-BS 2.5 ⁴⁾	05459	RDS 1 ⁴⁾	01314	—	—	MD	05849	WS	01271
FU-BS 2.5 ⁴⁾	05459	RDS 1 ⁴⁾	01314	—	—	MD	05849	WS	01271
FU-BS 2.5 ⁴⁾	05459	RDS 1 ⁴⁾	01314	—	—	MD	05849	WS	01271
—	—	Pole changing switch		—	—	—	—	—	—
—	—	PDA 12 ⁵⁾	05081	—	—	M 3 ⁶⁾	01293	PWDA	01282
—	—	not permitted	not permitted	not permitted	not permitted	—	—	—	—
—	—	not permitted	not permitted	not permitted	not permitted	—	—	—	—
—	—	not permitted	not permitted	not permitted	not permitted	—	—	—	—
—	—	not permitted	not permitted	not permitted	not permitted	—	—	—	—

⁴⁾ Incl. motor protection circuit breaker. ⁵⁾ Incl. speed pole changing switch. ⁶⁾ Flush-m. version see Switch product page.

Other accessories Page

- ^{b)} Access. for expl.-proof fans
- Flanged flexible connector STS 250 Ex Ref. no. 02501
- Flexible connecting sleeve FM 250 Ex Ref. no. 01688
- Extension sleeve for HS VH 250 Ref. no. 01343
- Cylindrical pipe section, galvanised steel, 15 cm long.
- Filter and silencers 481 ff.
- Shutters and ventilation grilles 561 ff.
- Speed controllers, controllers and switches 599 ff.

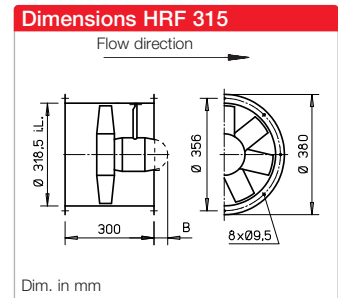
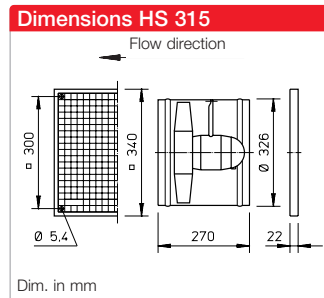
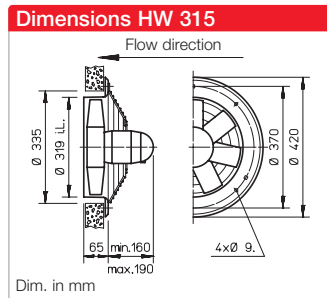
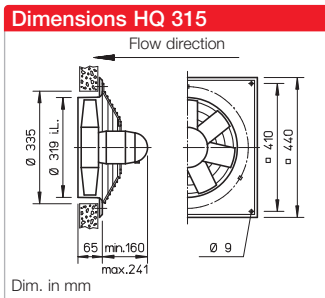

Description for all types

- **Casing**
 Made of galvanised steel sheet, types HQ and HW have additional two layer lacquer coating in papyrus white. Explosion-proof types have no lacquer coating.
- **Impeller**
 High performance characteristics with profiled blades made of plastic, dynamically balanced. Different for explosion-proof types.
- **Drive**
 Closed die-cast aluminium casing. Prot. cat. IP55. Ball bearing mounted. Maintenance-free and radio interference-free. Winding with moisture proof coating. See type table for max. air flow temperature. Different for explosion-proof types.

- **Motor protection**
 All types (except for 3~ explosion-proof, see page 180) are equipped with thermal contacts. These should be wired with the motor protection circuit breaker (see type table) for effective motor protection.
 For types H..W 315/6 and all 1~ explosion-proof fans, the thermal contacts are wired in series with the winding, automatic deactivation and reactivation after cool down.
- **Electrical connection**
 Standard terminal box (IP55) on back of motor. Additionally on outside of duct for HRF types. Different for explosion-proof types.

- **Protection grille**
 Made of powder-coated steel for HQ/HW (HQ Ex galvanised), and plastic for HS. In accordance with DIN EN ISO 13857.
- **Power control**
 The voltage-controllable types are identified in the "Current consumption max. with control" column with a value which must be observed when determining the controller (see speed controller column). Possible assignments of frequency inverters to fans are shown in the type table. The flow rates are shown in the performance diagram.
- **Reverse operation**
 All types are reversible using a reverser switch. Performance reduction of approx. 1/3 in abnormal flow direction.

- **Installation**
 Installation possible in any position, but be aware of any condensate drain holes depending on usage.
- **Dimensions**
 Pole-changeable and explosion-proof types may differ from the above information.
- **Noise levels**
 See performance diagram. The sound power and sound pressure at 4 m distance under free field conditions are specified for the average operating point on the inlet/outlet side. See page 14 f for noise emissions and room acoustics. Different for explosion-proof types.

Speed	Flow rate free-blowing	Power consump.	Current consump.		Wiring diagram	Max. air flow temp.		Weight net aprx.	Design type							
			at rated voltage	max. with control		at rated voltage	with control		HQ incl. protection grille	Ref. no.	HW incl. protection grille	Ref. no.	HS incl. protection grille	Ref. no.	HRF	Ref. no.
min ⁻¹	V m ³ /h	W	A	A	No.	+ °C	+ °C	kg								
Single-phase alternating current, 230 Volt, 50 Hz, Capacitor motor, protection category IP55																
920	1330	33	0.25	0.35	317 ¹⁾	60	40	9.0	HQW 315/6	01105	—	HSW 315/6	00142	HRFW 315/6¹⁾	00202	
1390	2080	104	0.45	0.47	475 ¹⁾	60	40	8.0	HQW 315/4	01106	HWW 315/4	01004	HSW 315/4	00143	HRFW 315/4²⁾	00203
Three-phase current, 400 Volt, 50 Hz, Squirrel-cage rotor, protection category IP55																
950	1370	68	0.27	0.32	469	60	40	9.0	HQD 315/6	01117	—	—	—	—	—	
1330	1960	84	0.24	0.26	469	60	40	9.0	HQD 315/4	01118	HWD 315/4	01019	HSD 315/4	00158	HRFD 315/4	00223
2760	4080	527	1.10	1.23	469	50	40	11.0	HQD 315/2	01119	HWD 315/2	01020	—	—	HRFD 315/2	00224
Two-speed, three-phase current, 400 V, 50 Hz, √3 connection, protection category IP55																
1040/1280	1530/1980	56/87	0.11/0.22	—	520	60	—	10.5	HQD 315/4/4	01460	—	—	—	—	HRFD 315/4/4	01462
Pole-changeable, 2 speeds, three-phase current, Dahlander winding, 400 Volt, 50 Hz, protection category IP55																
720/1445	980/2060	49/115	0.20/0.43	—	472	60	—	12.0	HQD 315/8/4	01129	—	—	HSD 315/8/4	00346	HRFD 315/8/4	00391
1445/2845	2100/4190	106/558	0.45/1.32	—	472	50	—	12.5	HQD 315/4/2	01131	—	—	HSD 315/4/2	00348	HRFD 315/4/2	00393
Ex	Explosion-proof, II 2G Ex h IIB T3 Gb, Motor Ex d, alternating current 230 Volt, 50 Hz, protection category IP55															
1370	2070	60*	1.25*	—	757	40	—	13.0	HQW 315/4 Ex	00442	—	—	—	—	HRFW 315/4 Ex	00439
Ex	Explosion-proof, II 2G Ex h IIB + H₂ T3 Gb, Motor Ex e, three-phase current 400 Volt, 50 Hz, protection category IP55															
920	1400	250*	0.97*	—	470	40	—	23.0	HQD 315/6 Ex	01098	—	—	—	—	—	
1355	2140	120*	0.37*	—	470	40	—	14.0	HQD 315/4 Ex	01147	—	—	—	—	HRFD 315/4 Ex	00473
2900	4130	550*	1.31*	—	470	40	—	8.0	HQD 315/2 Ex	01148	—	—	—	—	HRFD 315/2 Ex	00474

* Motor ratings, Ex see information on page 20. ¹⁾ Type HRFW../6: Connection according to wiring diagram no. 963. ²⁾ Type HRFW../4: Connection according to wiring diagram no. 965. ³⁾ Incl. motor protection circuit breaker.

Performance curves 315/2

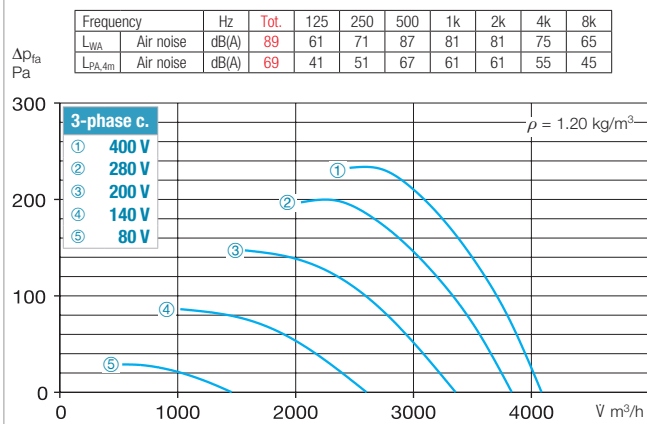

Performance curves 315/4

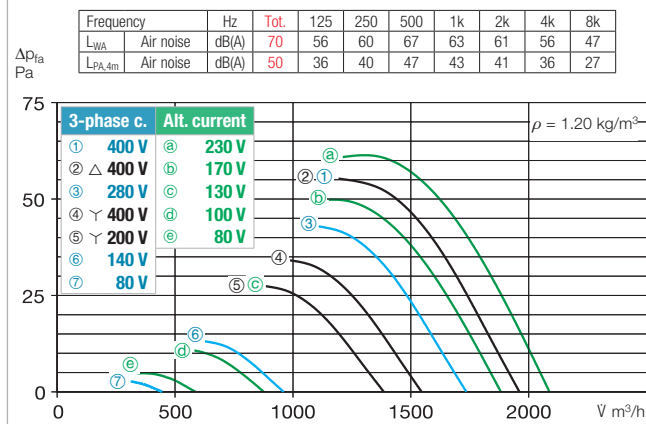

Performance curves 315/6

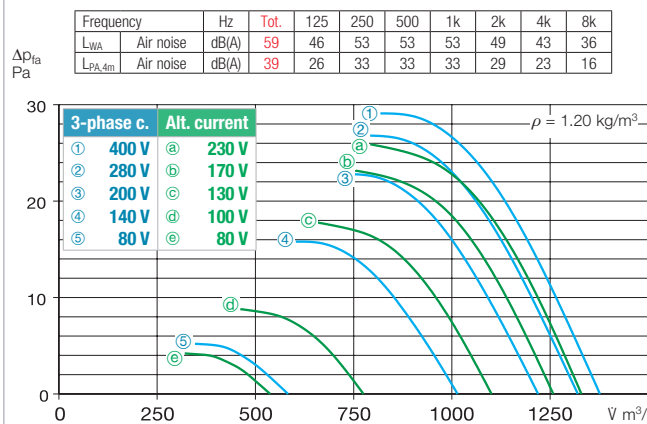

Performance curve 315/8

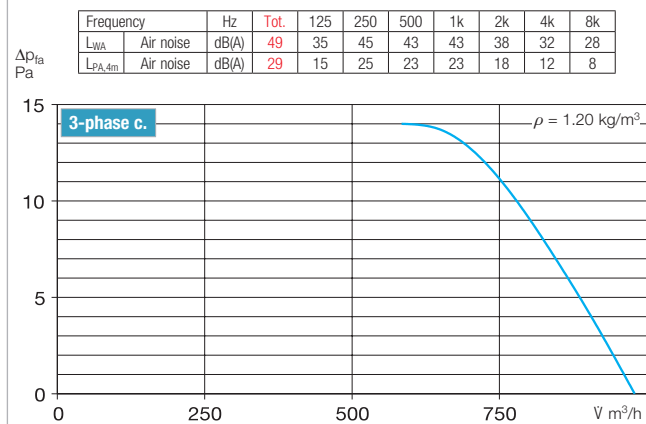

Accessories for HRF 315 Description see page 276 ff.

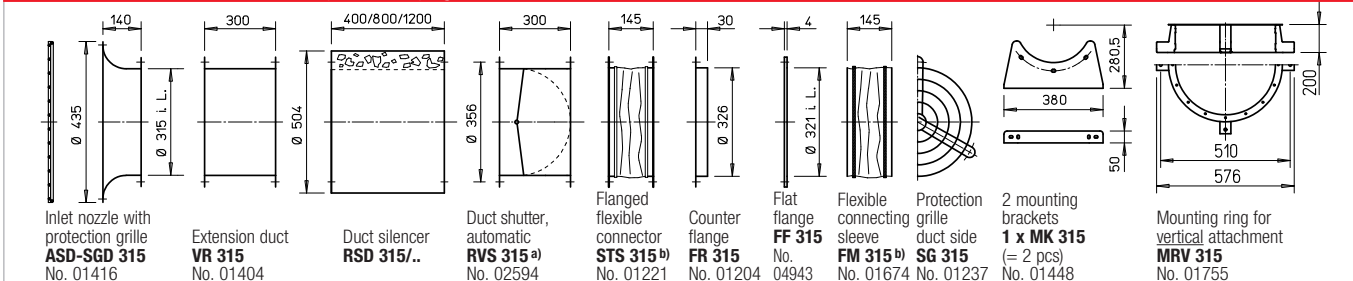

^{a)} Shutter, motorised see Accessories product pages.

^{b)} See below for types for explosion-proof fans.

Frequency inverter with integrated sine filter		Transformer speed controller 5-step, pole changing switch		Electronic speed controller, continuously variable flush-m./surface-m.		Motor protection circuit breaker for connecting built-in thermal contacts		Reverser switch	
Type	Ref. no.	Type	Ref. no.	Type	Ref. no.	Type	Ref. no.	Type	Ref. no.
—	—	TSW 0.3	03608	ESU 1/ESA 1	00236/00238	—	—	WS	01271
—	—	MWS 1.5³⁾	01947	ESU 1/ESA 1	00236/00238	MW	01579	WS	01271
FU-BS 2.5³⁾	05459	RDS 1³⁾	01314	—	—	MD	05849	WS	01271
FU-BS 2.5³⁾	05459	RDS 1³⁾	01314	—	—	MD	05849	WS	01271
FU-BS 2.5³⁾	05459	RDS 2³⁾	01315	EDS 5	00501	MD	05849	WS	01271
Speed changeover switch									
FU-BS 2.5³⁾	05459	DS2	01351	—	—	M 4⁴⁾ / MD	01571/05849	WS	01271
Pole changing switch									
—	—	PDA 12⁵⁾	05081	—	—	M 3⁴⁾	01293	PWDA	01282
—	—	PDA 12⁵⁾	05081	—	—	M 3⁴⁾	01293	PWDA	01282
—	—	not permitted	not permitted	not permitted	not permitted	—	—	—	—
—	—	not permitted	not permitted	not permitted	not permitted	—	—	—	—
—	—	not permitted	not permitted	not permitted	not permitted	—	—	—	—
—	—	not permitted	not permitted	not permitted	not permitted	—	—	—	—

⁴⁾ Incl. speed pole changing switch. ⁵⁾ Flush-m. version see Switch product page.

Other accessories Page

- ^{b)} Access. for expl.-proof fans
- Flanged flexible connector STS 315 Ex** Ref. no. 02503
- Flexible connecting sleeve FM 315 Ex** Ref. no. 01690
- Extension sleeve for HS VH 315** Ref. no. 01344
- Cylindrical pipe section, galvanised steel, 15 cm long.
- Filter and silencers 481 ff.
- Shutters and ventilation grilles 561 ff.
- Speed controllers, controllers and switches 599 ff.

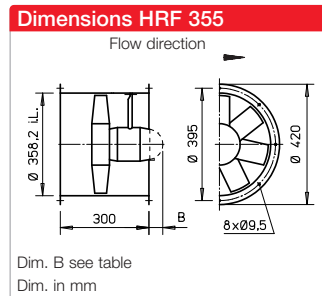
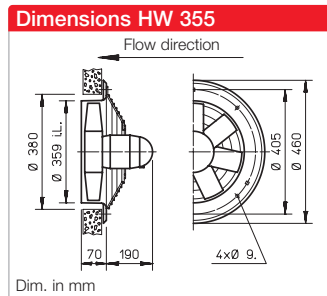
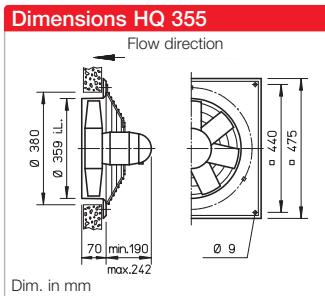

Description for all types

Casing

Made of galvanised steel sheet, types HQ and HW have additional two layer lacquer coating in papyrus white. Explosion-proof types have no lacquer coating.

Impeller

High performance characteristics with profiled blades made of plastic, dynamically balanced. Different for explosion-proof types.

Drive

Closed die-cast aluminium casing. Prot. cat. IP55. Ball bearing mounted. Maintenance-free and radio interference-free. Winding with moisture proof coating. See type table for max. air flow temperature. Different for explosion-proof types.

Motor protection

All types (except for 3~ explosion-proof, see page 180) are equipped with thermal contacts. These should be wired with the motor protection circuit breaker (see type table) for effective motor protection. For 1~ explosion-proof fans, the thermal contacts are wired in series with the winding, automatic deactivation and reactivation after cool down.

Electrical connection

Standard terminal box (IP55) on back of motor. Additionally on outside of duct for HRF types. Different for explosion-proof types.

Protection grille

Made of powder-coated steel for HQ and HW (HQ Ex galvanised). In accordance with DIN EN ISO 13857.

Power control

The voltage-controllable types are identified in the "Current consumption max. with control" column with a value which must be observed when determining the controller (see speed controller column). Possible assignments of frequency inverters to fans are shown in the performance diagram. The flow rates are shown in the performance diagram.

Reverse operation

All types are reversible using a reverser switch. Performance reduction of approx. 1/3 in abnormal flow direction.

Installation

Installation possible in any position, but be aware of any condensate drain holes depending on usage.

Dimensions

Pole-changeable and explosion-proof types may differ from the above information.

Noise levels

See performance diagram. The sound power and sound pressure at 4 m distance under free field conditions are specified for the average operating point on the inlet/outlet side. See page 14 f for noise emissions and room acoustics. Different for explosion-proof types.

Speed min ⁻¹	Flow rate free-blowing V m ³ /h	Power consump. W	Current consump.		Wiring diagram No.	Max. air flow temp.		Weight net appr. kg	Design type							
			at rated voltage A	max. with control A		at rated voltage + °C	with control + °C		HQ incl. protection grille	Ref. no.	HW incl. protection grille	Ref. no.	HRF	Ref. no.	Dim. B Motor protrusion in mm	
Single-phase alternating current, 230 Volt, 50 Hz, Capacitor motor, protection category IP55																
960	1940	75	0.47	0.47	475 ¹⁾	60	40	12	HQW 355/6	01107	—	—	HRFW 355/6 ¹⁾	00204	—	
1345	2850	130	0.60	0.65	475 ¹⁾	60	40	11	HQW 355/4	01108	HWW 355/4	01006	HRFW 355/4 ¹⁾	00205	10	
Three-phase current, 400 Volt, 50 Hz, Squirrel-cage rotor, protection category IP55																
960	1970	70	0.27	0.29	469	60	40	9.5	HQD 355/6	01120	—	—	—	—	—	
1375	2900	130	0.35	0.35	469	60	40	11.0	HQD 355/4	01121	HWD 355/4	01022	HRFD 355/4	00226	—	
2670	5710	825	1.60	1.60	469	60	40	15.0	HQD 355/2	01122	HWD 355/2	01023	HRFD 355/2	00227	—	
Two-speed, three-phase current, 400 V, 50 Hz, γ/Δ connection, protection category IP55																
1120/1350	2460/2860	90/132	0.17/0.32	—	520	60	—	11.0	HQD 355/4/4	01463	—	—	HRFD 355/4/4	01464	—	
Pole-changeable, 2 speeds, three-phase current, Dahlander winding, 400 Volt, 50 Hz, protection category IP55																
700/1395	1430/2920	45/145	0.14/0.35	—	472	60	—	11.0	HQD 355/8/4	01132	—	—	HRFD 355/8/4	00394	10	
1430/2840	3050/6150	250/950*	0.63/2.30*	—	472	40	—	16.0	HQD 355/4/2	01134	—	—	HRFD 355/4/2	00396	35	
Ex	Explosion-proof, II 2G Ex h IIB T3 Gb, Motor Ex d, alternating current 230 Volt, 50 Hz, protection category IP55															
1370	2940	180*	1.25*	—	757	40	—	18.0	HQW 355/4 Ex	00444	—	—	HRFW 355/4 Ex	00443	30	
Ex	Explosion-proof, II 2G Ex h IIB + H₂ T3 Gb, Motor Ex e, three-phase current 400 Volt, 50 Hz, protection category IP55															
920	2010	250*	0.97*	—	470	40	—	25.0	HQD 355/6 Ex	01101	—	—	—	—	—	
1355	3060	120*	0.37*	—	470	40	—	18.0	HQD 355/4 Ex	01150	—	—	HRFD 355/4 Ex	00476	—	
2900	5910	550*	1.31*	—	470	40	—	12.5	HQD 355/2 Ex	01151	—	—	HRFD 355/2 Ex	00477	—	

* Motor ratings, Ex see information on page 20.

¹⁾ Type HRFW: Connection according to wiring diagram no. 965.

²⁾ Incl. motor protection circuit breaker.

³⁾ Incl. speed pole changing switch.

Performance curves 355/2

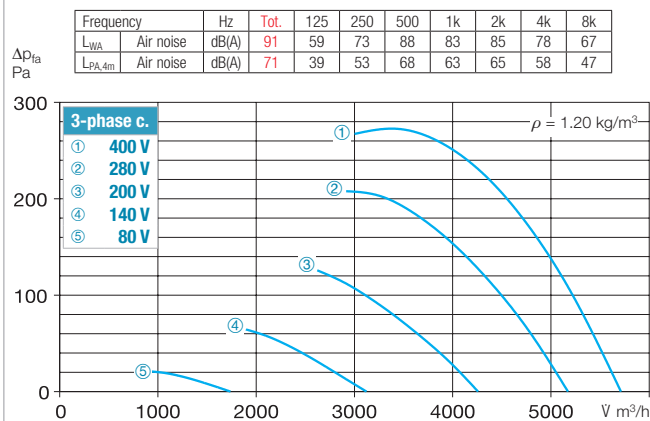

Performance curves 355/4

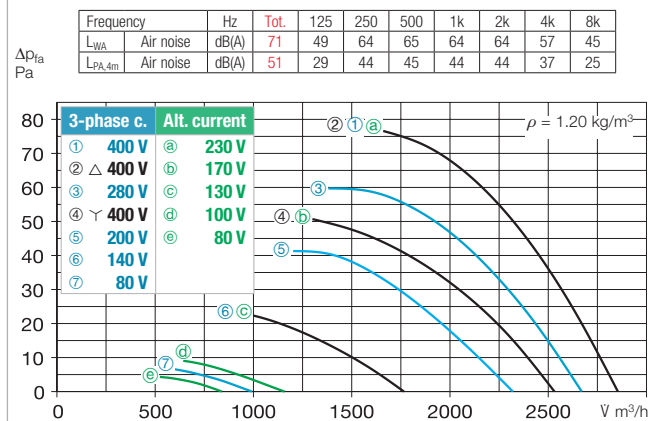

Performance curves 355/6

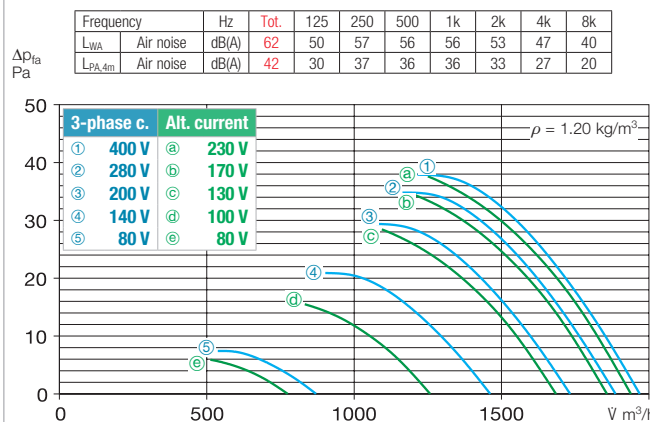

Performance curve 355/8

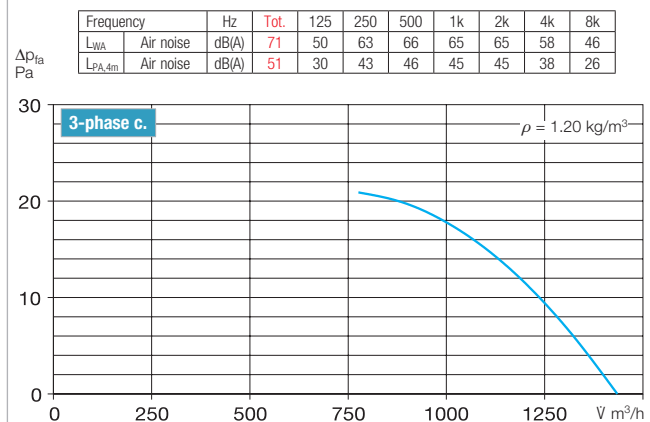

Accessories for HRF 355 Description see page 276 ff.

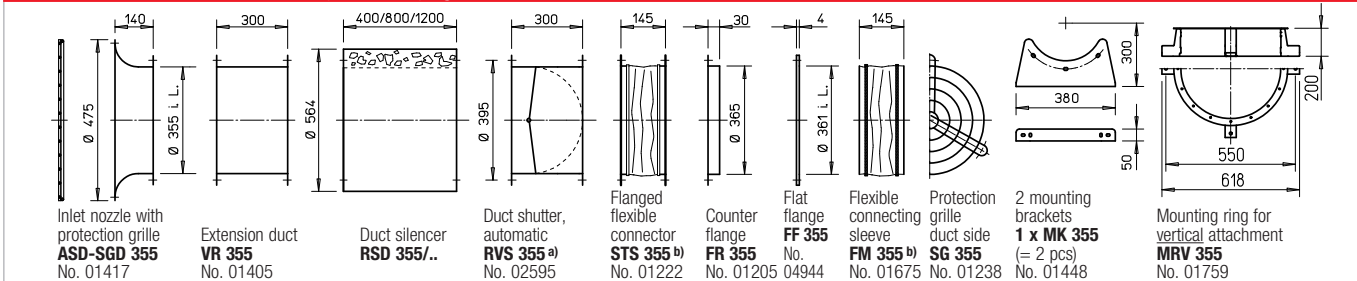

a) Shutter, motorised see Accessories product pages.

b) See below for types for explosion-proof fans.

Frequency inverter with integrated sine filter	Transformer speed controller 5-step, pole changing switch	Electronic speed controller, continuously variable flush-m./surface-m.	Motor protection circuit breaker for connecting built-in thermal contacts	Reverser switch	
Type	Ref. no.	Type	Ref. no.	Type	Ref. no.
—	MWS 1.5 ²⁾ 01947	ESU 1/ESA 1 00236/00238	MW 01579	WS 01271	
—	MWS 1.5 ²⁾ 01947	ESU 1/ESA 1 00236/00238	MW 01579	WS 01271	
FU-BS 2.5 ²⁾ 05459	RDS 1 ²⁾ 01314	—	MD 05849	WS 01271	
FU-BS 2.5 ²⁾ 05459	RDS 1 ²⁾ 01314	—	MD 05849	WS 01271	
FU-BS 2.5 ²⁾ 05459	RDS 2 ²⁾ 01315	ESD 5 00501	MD 05849	WS 01271	
—	Speed changeover switch DS 2 01351	—	M 4 ³⁾ /MD 01571/05849	WS 01271	
—	Pole changing switch PDA 12 ⁴⁾ 05081	—	M 3 ³⁾ 01293	PWDA 01282	
—	PDA 12 ⁴⁾ 05081	—	MSA 01289	PWDA 01282	
—	not permitted	not permitted	—	—	
—	not permitted	not permitted	—	—	
—	not permitted	not permitted	—	—	
—	not permitted	not permitted	—	—	

⁴⁾ Flush-m. version see Switch product page.

Other accessories Page

- ^{b)} Access. for expl.-proof fans
- Flanged flexible connector STS 355 Ex Ref. no. 02504
- Flexible connecting sleeve FM 355 Ex Ref. no. 01691
- Extension sleeve for HS VH 355 Ref. no. 01345
- Cylindrical pipe section, galvanised steel, 15 cm long.
- Filter and silencers 481 ff.
- Shutters and ventilation grilles 561 ff.
- Speed controllers, controllers and switches 599 ff.

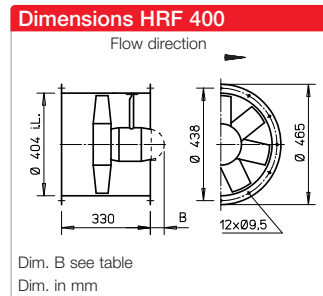
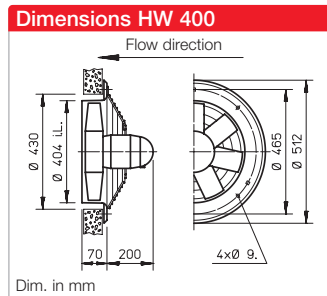
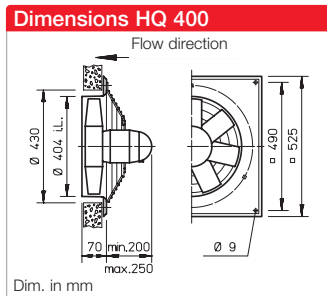

Description for all types

Casing

Made of galvanised steel sheet, types HQ and HW have additional two layer lacquer coating in papyrus white. Explosion-proof types have no lacquer coating

Impeller

High performance characteristics with profiled blades made of plastic, dynamically balanced. Different for explosion-proof types.

Drive

Closed die-cast aluminium casing. Prot. cat. IP55. Ball bearing mounted. Maintenance-free and radio interference-free. Winding with moisture proof coating. See type table for max. air flow temperature. Different for explosion-proof types.

Motor protection

All types (except for explosion-proof, see page 180) are equipped with thermal contacts. These should be wired with the motor protection circuit breaker (see type table) for effective motor protection.

Electrical connection

Standard terminal box (IP55) on back of motor. Additionally on outside of duct for HRF types. Different for explosion-proof types.

Protection grille

Made of powder-coated steel for HQ and HW (HQ Ex galvanised). In accordance with DIN EN ISO 13857.

Power control

The voltage-controllable types are identified in the "Current consumption max. with control" column with a value which must be observed when determining

the controller (see speed controller column). Possible assignments of frequency inverters to fans are shown in the type table. The planned use of a frequency inverter without a sine filter should be indicated when placing the order. This requires a change of fan version and additional costs, if necessary. The flow rates are shown in the perform. diagram.

Noise levels

See performance diagram. The sound power and sound pressure at 4 m distance under free field conditions are specified for the average operating point on the inlet/outlet side. See page 14 f for noise emissions and room acoustics. Different for explosion-proof types.

Reference	Page
Techn. description	180
Selection table	181
Planning information	14 ff.
Special design	
Different voltage, protection category, air flow direction, higher air flow temperature, acid protection and impeller in other materials upon request.	
The technical information on p. 19 ff. must be observed.	

Reverse operation

All types are reversible using a reverser switch. Performance reduction of approx. 1/3 in abnormal flow direction.

Installation

Installation possible in any position, but be aware of any condensate drain holes depending on usage.

Dimensions

Pole-changeable and explosion-proof types may differ from the above information.

Speed min ⁻¹	Flow rate free-blowing V m ³ /h	Power consump. W	Current consump.		Wiring diagram No.	Max. air flow temp.		Weight net aprx. kg	Design type						
			at rated voltage A	max. with control A		at rated voltage + °C	with control + °C		HQ incl. protection grille	Ref. no.	HW incl. protection grille	Ref. no.	HRF	Ref. no.	Dim. B Motor protrusion in mm
Single-phase alternating current, 230 Volt, 50 Hz, Capacitor motor, protection category IP55															
930	2570	77	0.52	0.54	475 ¹⁾	60	40	13.0	HQW 400/6	01110	—	—	HRFW 400/6 ¹⁾	00206	—
1350	4010	235	1.00	1.10	475 ¹⁾	60	40	14.0	HQW 400/4	01111	HWW 400/4	01008	HRFW 400/4 ¹⁾	00207	10
Three-phase current, 400 Volt, 50 Hz, Squirrel-cage rotor, protection category IP55															
950	2620	89	0.28	0.30	469	60	40	13.0	HQD 400/6	01123	—	—	—	—	—
1330	3960	200	0.40	0.40	469	60	40	14.0	HQD 400/4	01124	HWD 400/4	01025	HRFD 400/4	00229	—
Two-speed, three-phase current, 400 V, 50 Hz, γ/Δ connection, protection category IP55															
1325/1085	3170/3920	135/205	0.25/0.45	0.45	520	60	40	20.0	HQD 400/4/4	01465	—	—	HRFD 400/4/4	01466	—
2890/2600	7890/8400	1300/2310*	3.00/5.60*	4.70	520	60	40	25.0	HQD 400/2/2	01475	—	—	HRFD 400/2/2	01474	120
Pole-changeable, 2 speeds, three-phase current, Dahlander winding, 400 Volt, 50 Hz, protection category IP55															
690/1390	2010/4100	70/250	0.25/0.60	—	472	60	—	13.0	HQD 400/8/4	01137	—	—	HRFD 400/8/4	00399	10
1480/2940	4180/8540	300/2310*	1.00/5.20*	—	472	40	—	24.0	HQD 400/4/2	01139	—	—	HRFD 400/4/2	00401	120
Ex Ex Explosion-proof, II 2G Ex h IIB + H₂ T3 Gb, Motor Ex e, three-phase current 400 Volt, 50 Hz, protection category IP55															
920	2870	250*	0.97*	—	470	40	—	13.0	HQD 400/6 Ex	01109	—	—	—	—	—
1420	4380	370*	1.08*	—	470	40	—	16.0	HQD 400/4 Ex	01153	—	—	HRFD 400/4 Ex	00479	—

* Motor ratings, Ex see information on page 20. ¹⁾ Type HRFW: Connection according to wiring diagram no. 965 ²⁾ Incl. motor protection circuit breaker. ³⁾ Incl. speed pole changing switch.

Performance curves 400/2

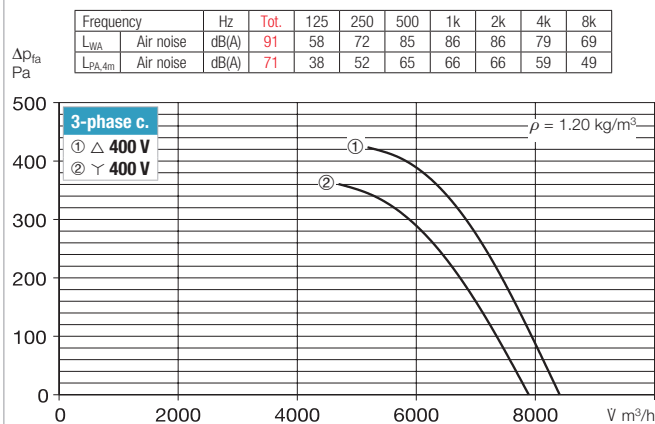

Performance curves 400/4

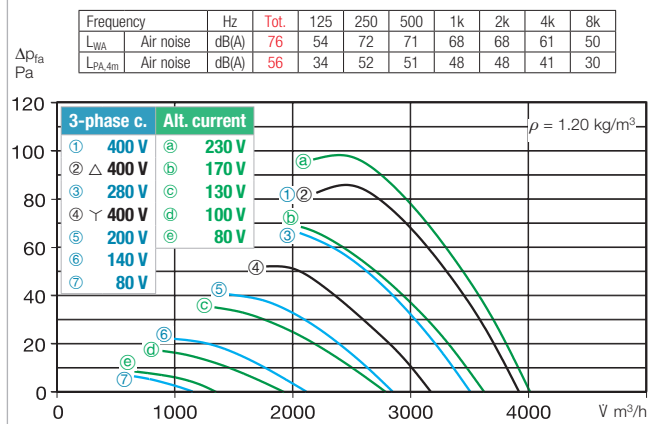

Performance curves 400/6

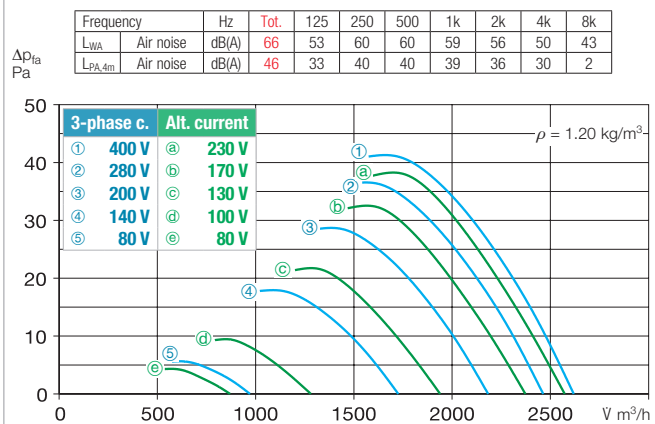

Performance curve 400/8

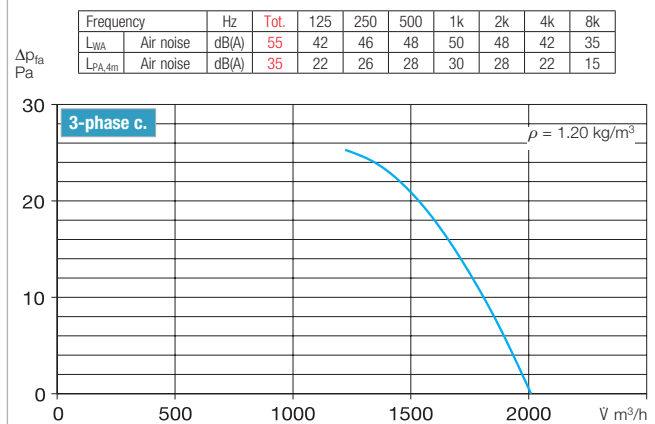

Accessories for HRF 400 Description see page 276 ff.

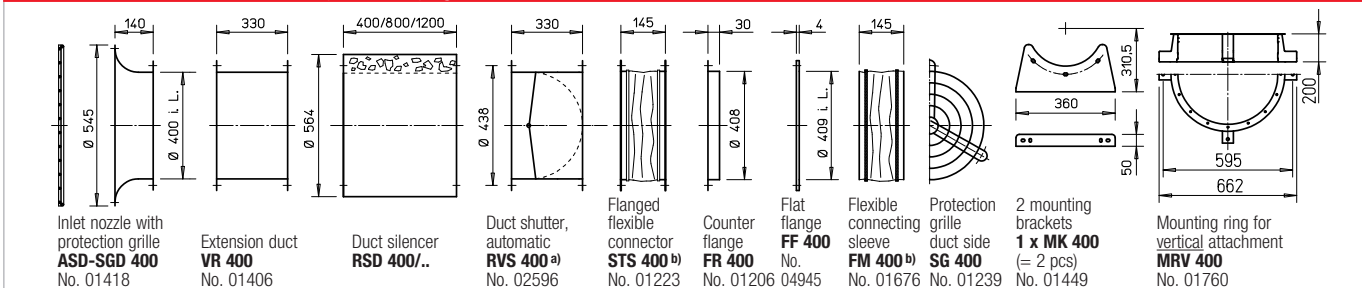

^{a)} Shutter, motorised see Accessories product pages.

^{b)} See below for types for explosion-proof fans.

Frequency inverter with integrated sine filter		Transformer speed controller 5-step, pole changing switch		Electronic speed controller, continuously variable flush-m./surface-m.		Motor protection circuit breaker for connecting built-in thermal contacts		Reverser switch	
Type	Ref. no.	Type	Ref. no.	Type	Ref. no.	Type	Ref. no.	Type	Ref. no.
—	—	MWS 1.5 ²⁾	01947	ESU 1/ESA 1	00236/00238	MW	01579	WS	01271
—	—	MWS 1.5 ²⁾	01947	ESU 1/ESA 1	00236/00238	MW	01579	WS	01271
FU-BS 2.5 ²⁾	05459	RDS 1 ²⁾	01314	—	—	MD	05849	WS	01271
FU-BS 2.5 ²⁾	05459	RDS 1 ²⁾	01314	—	—	MD	05849	WS	01271
Speed changeover switch									
FU-BS 2.5 ²⁾	05459	RDS 1 ²⁾	01314	—	—	M 4 ³⁾ /MD	01571/05849	WS	01271
FU-BS 5.0 ²⁾	05460	DS 2	01351	ESD 5 ²⁾	00501	M 4 ³⁾ /MD	01571/05849	WS	01271
Pole changing switch									
—	—	PDA 12 ⁴⁾	05081	—	—	M 3 ³⁾	01293	PWDA	01282
—	—	PDA 12 ⁴⁾	05081	—	—	M 3 ³⁾	01293	PWDA	01282
—	—	not permitted	—	not permitted	—	—	—	—	—
—	—	not permitted	—	not permitted	—	—	—	—	—

⁴⁾ Flush-m. version see Switch product page.

Other accessories Page

- ^{b)} Access. for expl.-proof fans
- Flanged flexible connector STS 400 Ex Ref. no. 02505
- Flexible connecting sleeve FM 400 Ex Ref. no. 01692
- Extension sleeve for HS VH 400 Ref. no. 01346
- Cylindrical pipe section, galvanised steel, 15 cm long.
- Filter and silencers 481 ff.
- Shutters and ventilation grilles 561 ff.
- Speed controllers, controllers and switches 599 ff.

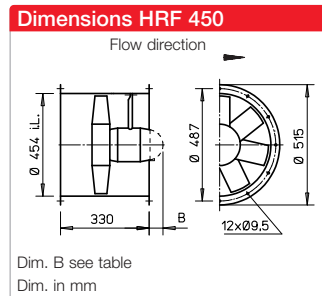
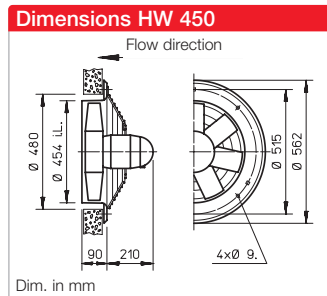
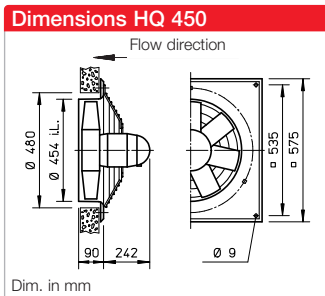

Description for all types

Casing

Made of galvanised steel sheet, types HQ and HW have additional two layer lacquer coating in papyrus white. Explosion-proof types have no lacquer coating

Impeller

High performance characteristics with profiled blades made of plastic, dynamically balanced. Different for explosion-proof types.

Drive

Closed die-cast aluminium casing. Prot. cat. IP55. Ball bearing mounted. Maintenance-free and radio interference-free. Winding with moisture proof coating. See type table for max. air flow temperature. Different for explosion-proof types.

Motor protection

All types (except for explosion-proof, see page 180) are equipped with thermal contacts. These should be wired with the motor protection circuit breaker (see type table) for effective motor protection.

Electrical connection

Standard terminal box (IP55) on back of motor. Additionally on outside of duct for HRF types. Different for explosion-proof types.

Protection grille

Made of powder-coated steel for HQ and HW (HQ Ex galvanised). In accordance with DIN EN ISO 13857.

Power control

The voltage-controllable types are identified in the "Current consumption max. with control" column with a value which must be observed when determining the controller (see speed controller column). Possible assignments of frequency inverters to fans are shown in the type table. The planned use of a frequency inverter without a sine filter should be indicated when placing the order. This requires a change of fan version and additional costs, if necessary. The flow rates are shown in the performance diagram.

Reverse operation

All types are reversible using a reverser switch. Performance reduction of approx. 1/3 in abnormal flow direction.

Installation

Installation possible in any position, but be aware of any condensate drain holes depending on usage.

Dimensions

Pole-changeable and explosion-proof types may differ from the above information.

Noise levels

See performance diagram. The sound power and sound pressure at 4 m distance under free field conditions are specified for the average operating point on the inlet/outlet side. See page 14 f for noise emissions and room acoustics. Different for explosion-proof types.

Speed min ⁻¹	Flow rate free-blowing V m ³ /h	Power consump. W	Current consump.		Wiring diagram No.	Max. air flow temp.		Weight net aprx. kg	Design type															
			at rated voltage A	max. with control A		at rated voltage + °C	with control + °C		HQ incl. protection grille	Ref. no.	HW incl. protection grille	Ref. no.	HRF	Ref. no.	Dim. B Motor protrusion in mm									
Single-phase alternating current, 230 Volt, 50 Hz, Capacitor motor, protection category IP55																								
915	3890	136	0.63	0.63	475 ¹⁾	60	40	19.0	HQW 450/6	00991	—	—	HRFW 450/6 ¹⁾	00208	—									
1380	5770	405	1.76	2.02	475 ¹⁾	60	40	18.0	HQW 450/4	00992	HWW 450/4	01010	HRFW 450/4 ¹⁾	00209	—									
Three-phase current, 400 Volt, 50 Hz, Squirrel-cage rotor, protection category IP55																								
960	3920	137	0.38	0.42	469	60	40	18.0	HQD 450/6	00993	—	—	HRFD 450/6	00230	—									
1390	5810	384	0.81	0.92	469	50	40	17.0	HQD 450/4	00994	HWD 450/4	01028	HRFD 450/4	00231	—									
Two-speed, three-phase current, 400 V, 50 Hz, ∇/Δ connection, protection category IP55																								
1130/1390	5090/5780	280/378	0.51/0.82	—	520	60	—	22.0	HQD 450/4/4	01467	—	—	HRFD 450/4/4	01468	—									
2775/2200	10190/9335	1300/2310*	5.40/3.0*	5.10	520	40	40	32.0	—	—	—	—	HRFD 450/2/2	00484	150									
Pole-changeable, 2 speeds, three-phase current, Dahlander winding, 400 Volt, 50 Hz, protection category IP55																								
480/970	1930/3950	62/163	0.22/0.47	—	472	60	—	18.0	HQD 450/12/6	00995	—	—	—	—	—									
705/1410	2860/5810	91/404	0.36/0.92	—	472	50	—	20.0	HQD 450/8/4	00996	—	—	HRFD 450/8/4	00403	—									
Ex Explosion-proof, II 2G Ex h IIB + H₂ T3 Gb, Motor Ex e, three-phase current 400 Volt, 50 Hz, protection category IP55																								
920	4090	250*	0.97*	—	470	40	—	15.5	HQD 450/6 Ex	01473	—	—	—	—	—									
1420	6240	370*	1.08*	—	470	40	—	15.5	HQD 450/4 Ex	01154	—	—	HRFD 450/4 Ex	00481	—									

* Motor ratings, Ex see information on page 20. ¹⁾ Type HRFW: Connection according to wiring diagram no. 965. ²⁾ Incl. motor protection circuit breaker. ³⁾ Flush-m. version see Switch product page.

Performance curves 450/2

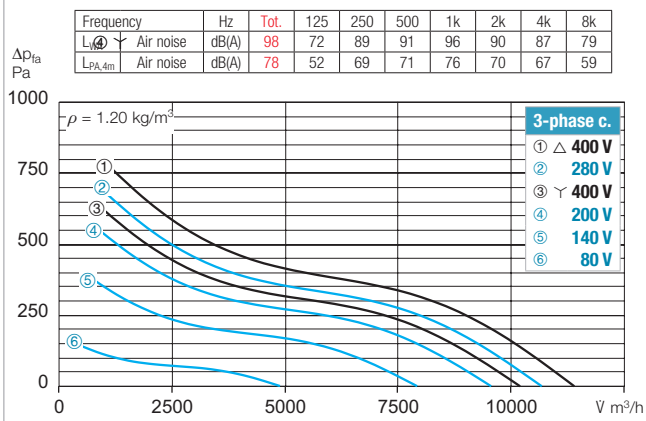

Performance curves 450/4

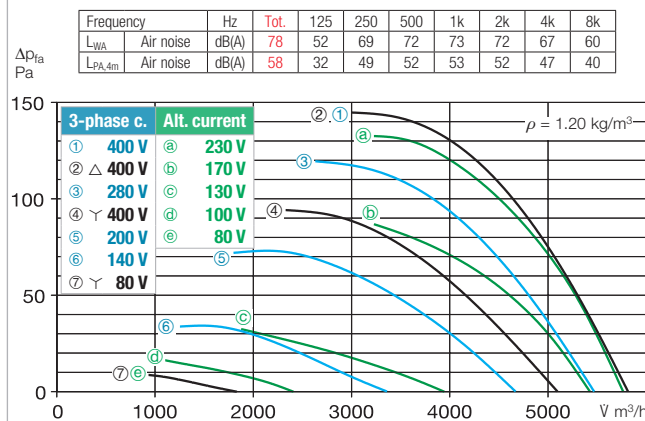

Performance curves 450/6

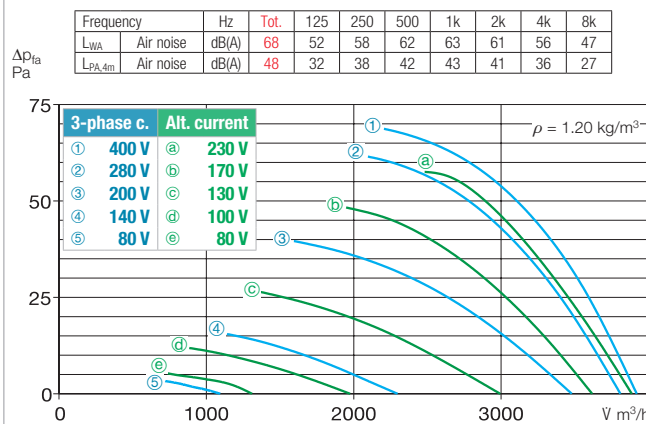

Performance curves 450/8

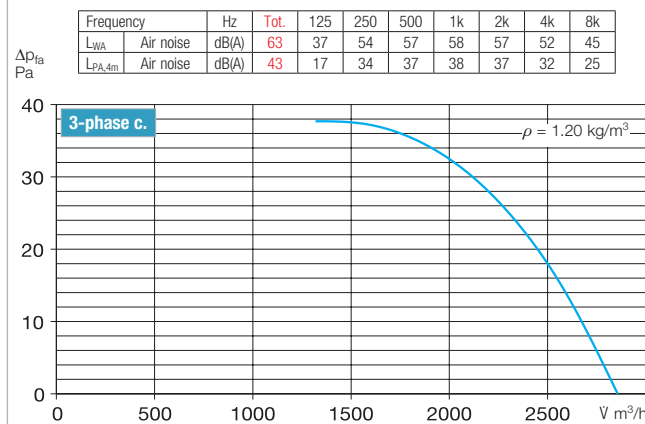

Accessories for HRF 450 Description see page 276 ff.

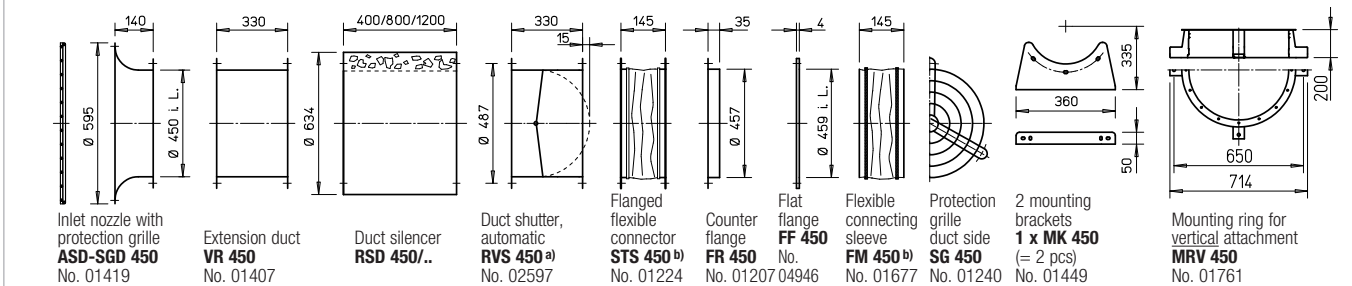

a) Shutter, motorised see Accessories product pages.

b) See below for types for explosion-proof fans.

Frequency inverter with integrated sine filter		Transformer speed controller 5-step, pole changing switch		Electronic speed controller, continuously variable flush-m./surface-m.		Motor protection circuit breaker for connecting built-in thermal contacts		Reverser switch	
Type	Ref. no.	Type	Ref. no.	Type	Ref. no.	Type	Ref. no.	Type	Ref. no.
—	—	MWS 1.5 2)	01947	ESU 3/ESA 3	00237/00239	MW	01579	WS	01271
—	—	MWS 3 2)	01948	ESU 3/ESA 3	00237/00239	MW	01579	WS	01271
FU-BS 2.5 2)	05459	RDS 1 2)	01314	—	—	MD	05849	WS	01271
FU-BS 2.5 2)	05459	RDS 2 2)	01315	EDS 5 2)	00501	MD	05849	WS	01271
Speed changeover switch									
FU-BS 2.5 2)	05459	DS 2 2)	01351	—	—	M 4 3)/MD	01571/05849	WS	01271
FU-BS 8.0 2)	05461	RDS 7 2)	01578	ESD 11.5 2)	00502	M 4 3)/MD	01571/05849	WS	01271
Pole changing switch									
—	—	PDA 12 3)	05081	—	—	M 3 4)	01293	PWDA	01282
—	—	PDA 12 3)	05081	—	—	M 3 4)	01293	PWDA	01282
—	—	not permitted	not permitted	not permitted	not permitted	—	—	—	—
—	—	not permitted	not permitted	not permitted	not permitted	—	—	—	—

4) Incl. speed pole changing switch.

5) Speed changeover switch.

Other accessories Page

b) Access. for expl.-proof fans	
Flanged flexible connector STS 450 Ex	Ref. no. 02506
Flexible connecting sleeve FM 450 Ex	Ref. no. 01693
Filter and silencers	481 ff.
Shutters and ventilation grilles	561 ff.
Speed controllers, controllers and switches	599 ff.

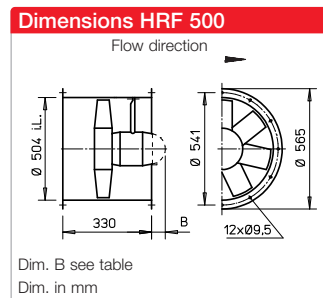
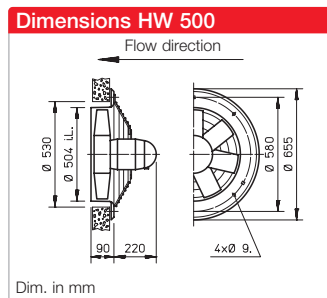
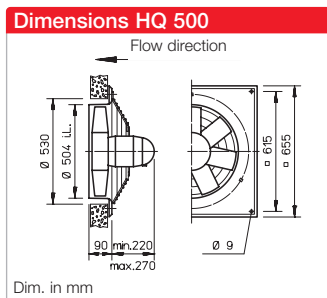

Description for all types

- Casing**
 Made of galvanised steel sheet, types HQ and HW have additional two layer lacquer coating in papyrus white. Explosion-proof types have no lacquer coating
- Impeller**
 High performance characteristics with profiled blades made of plastic, dynamically balanced. Different for explosion-proof types.
- Drive**
 Closed die-cast aluminium casing. Prot. cat. IP55. Ball bearing mounted. Maintenance-free and radio interference-free. Winding with moisture proof coating. See type table for max. air flow temperature. Different for explosion-proof types.

- Motor protection**
 All types (except for explosion-proof, see page 180) are equipped with thermal contacts. These should be wired with the motor protection circuit breaker (see type table) for effective motor protection.
- Electrical connection**
 Standard terminal box (IP55) on back of motor. Additionally on outside of duct for HRF types. Different for explosion-proof types.
- Protection grille**
 Made of powder-coated steel for HQ and HW (HQ Ex galvanised). In accordance with DIN EN ISO 13857.
- Power control**
 The voltage-controllable types are identified in the "Current consumption max. with control"

column with a value which must be observed when determining the controller (see speed controller column). Possible assignments of frequency inverters to fans are shown in the type table. The planned use of a sine filter should be indicated when placing the order. This requires a change of fan version and additional costs, if necessary. The flow rates are shown in the performance diagram.

- Reverse operation**
 All types are reversible using a reverser switch. Performance reduction of approx. 1/3 in abnormal flow direction.
- Installation**
 Installation possible in any position, but be aware of any condensate drain holes depending on usage.

Dimensions
 Pole-changeable and explosion-proof types may differ from the above information.

Noise levels
 See performance diagram. The sound power and sound pressure at 4 m distance under free field conditions are specified for the average operating point on the inlet/outlet side. See page 14 f for noise emissions and room acoustics. Different for expl.-proof types.

Reference	Page
Techn. description	180
Selection table	181
Planning information	14 ff.

Special design
 Different voltage, protection category, air flow direction, higher air flow temperature, acid protection and impeller made of cast aluminium upon request.

Speed min ⁻¹	Flow rate free-blowing V m ³ /h	Power consump. W	Current consump.		Wiring diagram No.	Max. air flow temp.		Weight net aprx. kg	Design type						
			at rated voltage A	max. with control A		at rated voltage + °C	with control + °C		HQ incl. protection grille	Ref. no.	HW incl. protection grille	Ref. no.	HRF	Ref. no.	Dim. B Motor protrusion in mm
Single-phase alternating current, 230 Volt, 50 Hz, Capacitor motor, protection category IP55															
935	5500	233	1.05	1.25	475 ¹⁾	60	40	19.0	HQW 500/6	01112	—	—	HRFW 500/6 ¹⁾	00210	—
1375	8320	1100*	5.90*	4.94	475 ¹⁾	40	40	25.0	HQW 500/4	01113	—	—	HRFW 500/4 ¹⁾	00211	60
Three-phase current, 400 Volt, 50 Hz, Squirrel-cage rotor, protection category IP55															
920	5480	218	0.48	0.55	469	60	40	19.0	HQD 500/6	01126	—	—	HRFD 500/6	00232	—
1345	8200	620	1.22	1.32	469	40	40	19.5	HQD 500/4	01127	HWD 500/4	01030	HRFD 500/4	00233	—
Two-speed, three-phase current, 400 V, 50 Hz, Y/Δ connection, protection category IP55															
615/920	4330/5450	133/214	0.29/0.46	—	520	60	—	18.0	HQD 500/6/6	01471	—	—	—	—	—
1030/1350	6720/8150	416/617	0.76/1.19	—	520	60	—	24.0	HQD 500/4/4	01469	—	—	HRFD 500/4/4	01470	120
2450/2830	13615/12050	1960/2470*	3.14/4.73*	—	520	40	—	30.0	—	—	—	—	HRFD 500/2/2	00485	150
Pole-changeable, 2 speeds, three-phase current, Dahlander winding, 400 Volt, 50 Hz, protection category IP55															
465/940	2680/5490	71/248	0.23/0.56	—	472	60	—	18.0	HQD 500/12/6	01140	—	—	—	—	—
700/1385	3890/8280	137/688	0.52/1.48	—	472	40	—	22.0	HQD 500/8/4	01142	—	—	HRFD 500/8/4	00407	—
Ex Ex Explosion-proof, II 2G Ex h IIB + H₂ T3 Gb, Motor Ex e, three-phase current 400 Volt, 50 Hz, protection category IP55															
920	5610	250*	0.97*	—	470	40	—	18.0	HQD 500/6 Ex	01050	—	—	HRFD 500/6 Ex	00489	10
1430	8330	550*	1.75*	—	470	40	—	18.0	HQD 500/4 Ex	01157	—	—	HRFD 500/4 Ex	00483	45

* Motor ratings, Ex see information on page 20. ¹⁾ Type HRFW: Connection according to wiring diagram no. 965. ²⁾ Incl. motor protection circuit breaker. ³⁾ Incl. speed pole changing switch.

Performance curves 500/2

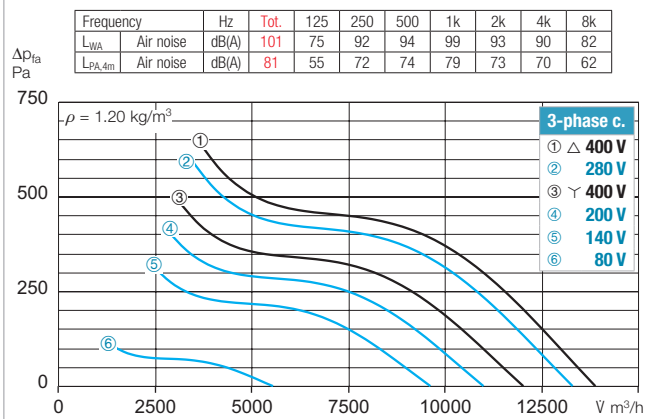

Performance curves 500/4

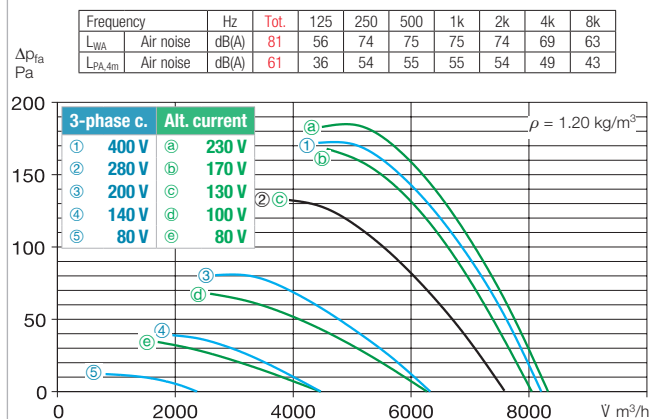

Performance curves 500/6

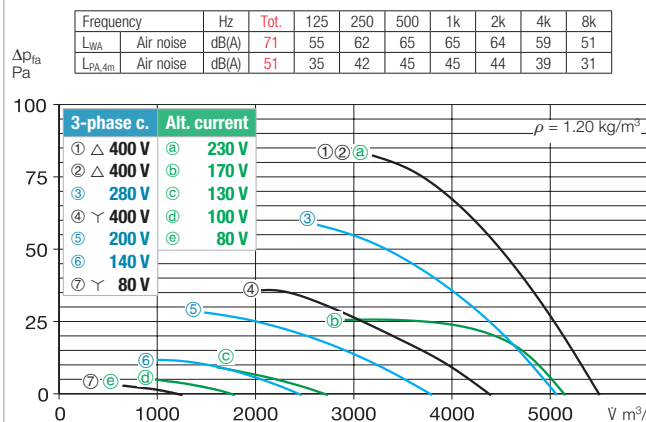

Performance curve 500/8

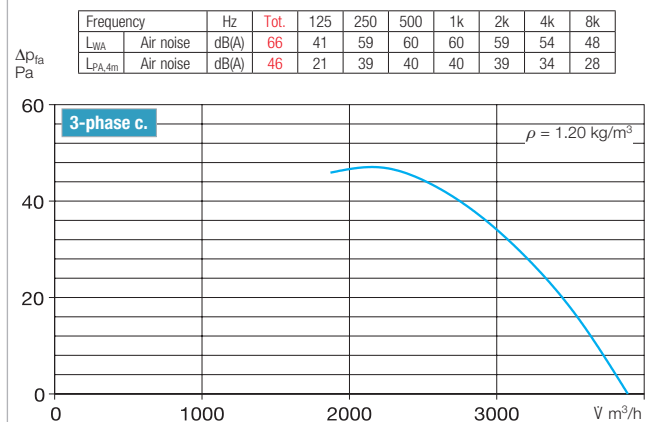

Accessories for HRF 500 Description see page 276 ff.

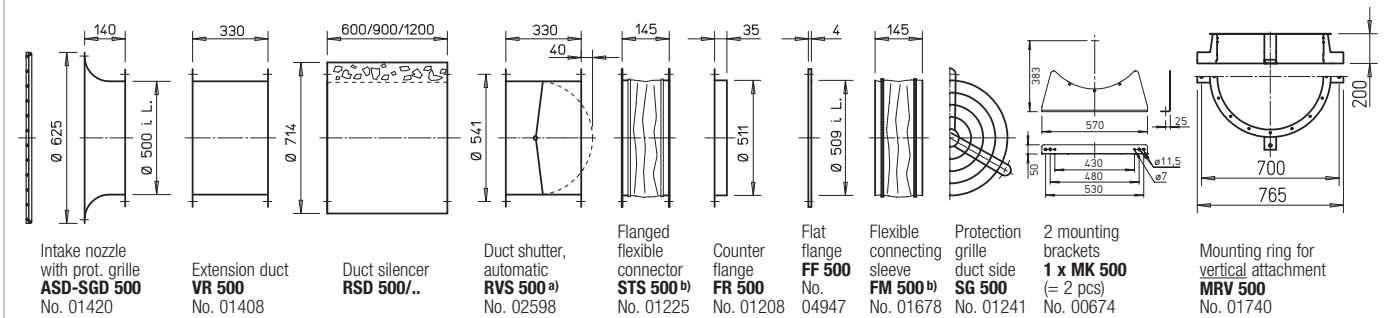

a) Shutter, motorised see Accessories product pages.

b) See below for types for explosion-proof fans.

Type	Ref. no.	Type	Ref. no.	Type	Ref. no.	Type	Ref. no.	Type	Ref. no.
Frequency inverter with integrated sine filter		Transformer speed controller 5-step, pole changing switch		Electronic speed controller, continuously variable flush-m./surface-m.		Motor protection circuit breaker for connecting built-in thermal contacts		Reverser switch	
—	MWS 1.5 2)	01947	ESU 3/ESA 3	00237/00239	MW	01579	WS	01271	
—	MWS 5 2)	01949	ESU 5/ESA 5	01296/01299	MW	01579	WS	01271	
FU-BS 2.5 2)	05459	RDS 1 2)	01314	ESD 5 2)	00501	MD	05849	WS	01271
FU-BS 2.5 2)	05459	RDS 2 2)	01315	ESD 5 2)	00501	MD	05849	WS	01271
Speed changeover switch									
FU-BS 2.5 2)	05459	DS 2 5)	01351	—	M 4 4)/MD	01571/05849	WS	01271	
FU-BS 2.5 2)	05459	DS 2 5)	01351	ESD 5 2)	00501	M 4 4)/MD	01571/05849	WS	01271
FU-BS 5.0 2)	05460	RDS 7 2)	01578	ESD 11.5 2)	00502	M 4 4)/MD	01571/05849	WS	01271
Pole changing switch									
—	PDA 12 4)	05081	—	M 3 3)	01293	PWDA	01282		
—	PDA 12 4)	05081	—	M 3 3)	01293	PWDA	01282		
—	not permitted		not permitted	—	—	—	—		
—	not permitted		not permitted	—	—	—	—		

4) Flush-m. version see Switch product page. 5) Speed changeover switch.

Other accessories Page

- Access. for expl.-proof fans
- Flanged flexible connector STS 500 Ex Ref. no. 02507
- Flexible connecting sleeve FM 500 Ex Ref. no. 01694
- Extension sleeve for HS VH 500 Ref. no. 01348
- Cylindrical pipe section, galvanised steel, 15 cm long.
- Filter and silencers 481 ff.
- Shutters and ventilation grilles 561 ff.
- Speed controllers, controllers and switches 599 ff.

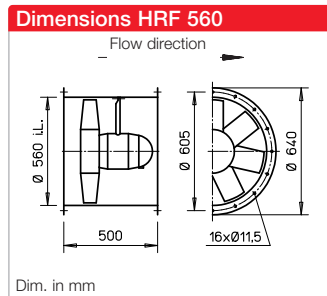
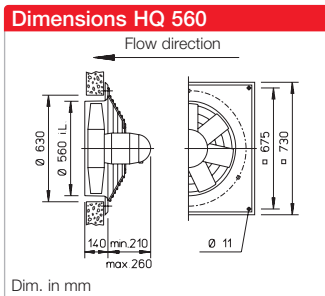

Description for all types

- Casing**
 Made of galvanised steel sheet. Type HQ has additional two layer lacquer coating in papyrus white. Explosion-proof types have no lacquer coating.
- Impeller**
 High performance characteristics with profiled blades made of plastic, dynamically balanced. Different for explosion-proof types.
- Drive**
 Closed die-cast aluminium casing. Protection category IP55. Ball bearing mounted. Maintenance-free and radio interference-free. Winding with moisture proof coating. See type table for max. air flow temperature. Different for explosion-proof types.

- Motor protection**
 All types (except for explosion-proof, see page 180) are equipped with thermal contacts. These should be wired with the motor protection circuit breaker (see type table) for effective motor protection.
- Electrical connection**
 Standard terminal box (IP55) on back of motor. Additionally on outside of duct for HRF types. Different for explosion-proof types.
- Protection grille**
 Made of powder-coated steel wire for HQ (Ex types galvanised). In accordance with DIN EN ISO 13857.

- Power control**
 The voltage-controllable types are identified in the "Current consumption max. with control" column with a value which must be observed when determining the controller (see speed controller column). Possible assignments of frequency inverters to fans are shown in the type table. The planned use of a frequency inverter without a sine filter should be indicated when placing the order. This requires a change of fan version and additional costs, if necessary. The flow rates are shown in the performance diagram.
- Reverse operation**
 All types are reversible using a reverser switch. Performance reduction of approx. 1/3 in abnormal flow direction.

- Installation**
 Installation possible in any position, but be aware of any condensate drain holes depending on usage.
- Dimensions**
 Pole-changeable and explosion-proof types may differ from the above information.
- Noise levels**
 See performance diagram. The sound power and sound pressure at 4 m distance under free field conditions are specified for the average operating point on the inlet/outlet side. See page 14 f for noise emissions and room acoustics. Different for explosion-proof types.

Speed min ⁻¹	Flow rate free-blowing V m ³ /h	Power consump. W	Current consump.		Wiring dia- gram No.	Max. air flow temp.		Weight net aprx. kg	Design type		Frequency inverter with integrated sine filter Type	Transformer speed con- troller 5-step, pole chan- ging switch, speed ch., pole changing switch Type				
			at rated voltage A	max. with control A		at rated voltage + °C	with control + °C		HQ incl. prot. grille Ref. no.	HRF Ref. no.			Ref. no.	Ref. no.		
Single-phase alternating current, 230 Volt, 50 Hz, Capacitor motor, protection category IP55																
935	8130	0.27	1.40	2.00	475 ¹⁾	60	40	24.0	HQW 560/6	00385	HRFW 560/6¹⁾	00380	—	MWS 3²⁾	01948	
1370	12180	0.89	4.15	5.00	965	60	40	31.0	HQW 560/4	05054	HRFW 560/4	05055	—	MWS 7.5²⁾	01950	
Three-phase current, 400 Volt, 50 Hz, Squirrel-cage rotor, protection category IP55																
965	8180	0.28	0.79	1.00	469	60	40	26.0	HQD 560/6	00386	HRFD 560/6	00381	FU-BS 2.5²⁾	05459	RDS 2²⁾	01315
1365	12250	0.88	1.71	1.80	469	40	40	29.0	HQD 560/4	00387	HRFD 560/4	00382	FU-BS 2.5²⁾	05459	RDS 2²⁾	01315
Pole-changeable, 2 speeds, three-phase current, Dahlander winding, 400 Volt, 50 Hz, protection category IP55																
470/955	4000/8130	0.089/0.298	0.55/0.74	—	472	60	—	24.0	HQD 560/12/6	00389	HRFD 560/12/6	00384	—	PDA 12³⁾	05081	
720/1365	6400/12130	0.20/0.92	0.80/1.77	—	472	40	—	26.0	HQD 560/8/4	00388	HRFD 560/8/4	00383	—	PDA 12³⁾	05081	
Ex Explosion-proof, II 2G Ex h IIB + H₂ T3 Gb, Motor Ex e, three-phase current 400 Volt, 50 Hz, protection category IP55																
920	8090	0.25*	0.97*	—	470	40	—	23.0	HQD 560/6 Ex	00378	HRFD 560/6 Ex	00376	—	Not permitted		
1445	12890	0.75*	3.20*	—	470	40	—	24.0	HQD 560/4 Ex	00379	HRFD 560/4 Ex	00377	—	Not permitted		

* For Ex types: Motor ratings see information on page 20. ¹⁾ Type HRFW: Connection according to wiring diagram no. 965. ²⁾ Incl. motor protection circuit breaker. ³⁾ Flush-m. version see Switch product page.

Performance curves 560/4

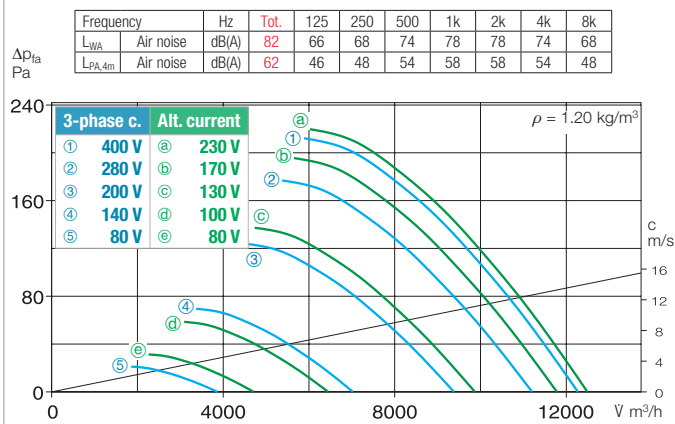

Performance curve 560/8

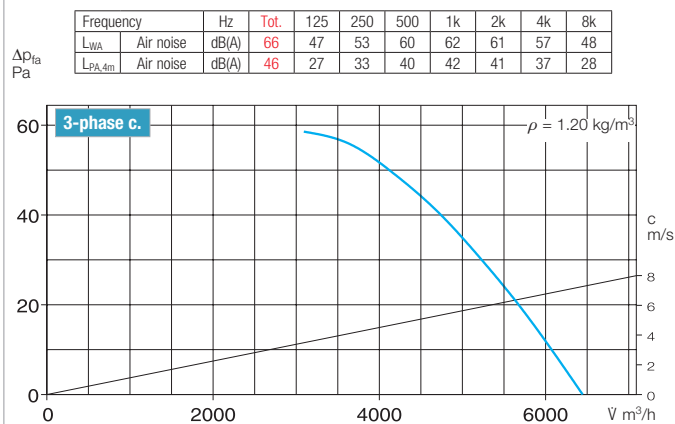

Performance curves 560/6

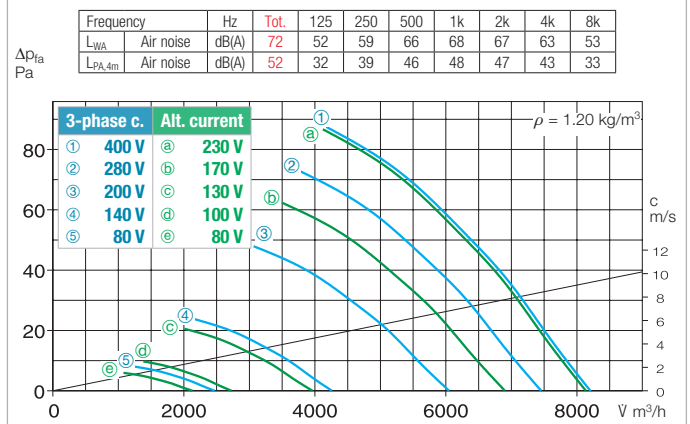

Performance curve 560/12

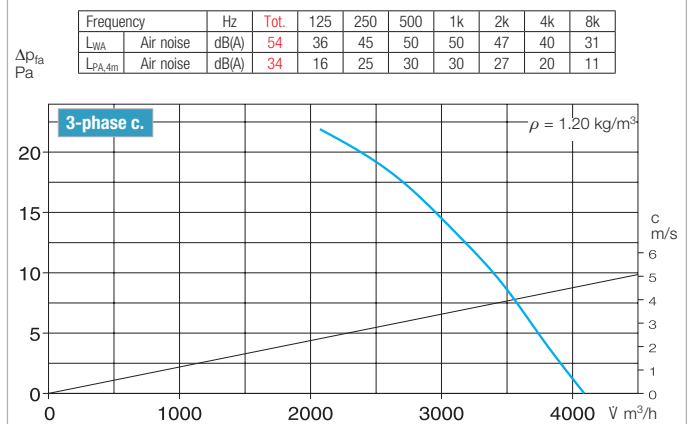

Accessories for HRF 560 Description see page 276 ff.

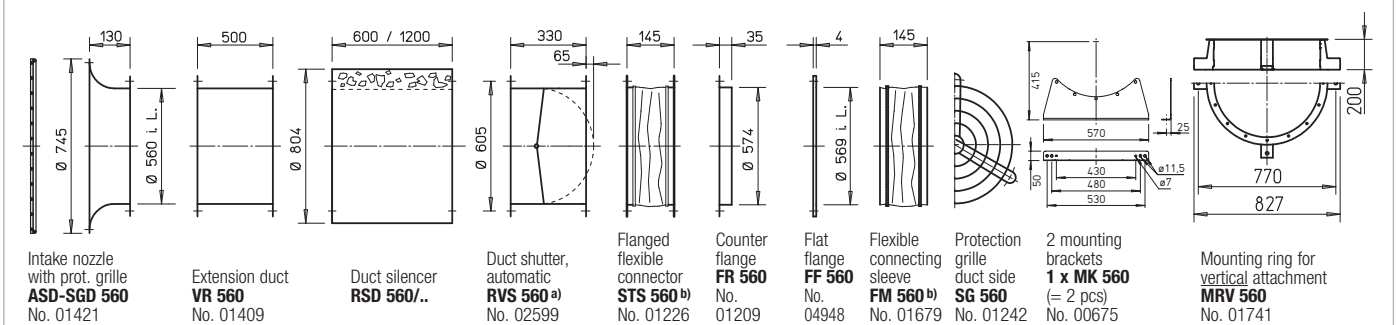

a) Shutter, motorised see Accessories product pages.

b) See below for types for explosion-proof fans.

Type	Ref. no.	Type	Ref. no.	Type	Ref. no.
Electronic speed controller, continuously variable flush-m./surface-m.		Motor protection circuit breaker for connecting built-in thermal contacts		Reverser switch	
ESU 3/ESA 3	00237/00239	MW	01579	WS	01271
ESU 5/ESA 5	01296/01299	MW	01579	WS	01271
ESD 5 a)	00501	MD	05849	WS	01271
ESD 5 a)	00501	MD	05849	WS	01271
—	—	M 3 a)	01293	PWDA	01282
—	—	M 3 a)	01293	PWDA	01282
not permitted	—	—	—	—	—
not permitted	—	—	—	—	—

a) Incl. speed pole changing switch.

Reference	Page
Techn. description	180
Selection table	181
Planning information	14 ff.
Special design	
Different voltage, protection category, air flow direction, higher air flow temperature, acid protection and impeller made of cast aluminium upon request.	
The technical information on p. 19 ff. must be observed.	

Other accessories	Page
b) Access. for expl.-proof fans	
Flanged flexible connector STS 560 Ex	Ref. no. 02508
Silencers	494 ff.
Shutters and ventilation grilles	561 ff.
Speed controllers, controllers and switches	599 ff.
Flexible connecting sleeve FM 560 Ex	Ref. no. 01695

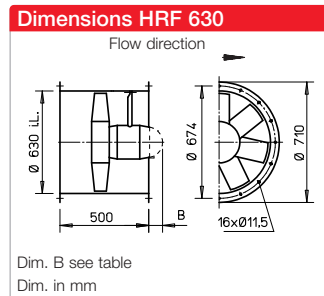
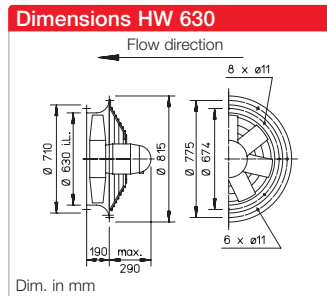
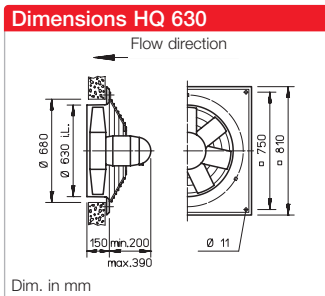

Description for all types

- **Casing**
 Made of galvanised steel sheet.
- **Impeller**
 High performance characteristics with profiled blades made of plastic, dynamically balanced. Different for explosion-proof types.
- **Drive**
 Closed die-cast aluminium casing. Protection category IP55. Ball bearing mounted. Maintenance-free and radio interference-free. Winding with moisture proof coating. See type table for max. air flow temperature. Different for explosion-proof types.
- **Motor protection**
 All types (except for ..8/4 and explosion-proof types, see page 180) are equipped with thermal contacts. These should be wired with the motor protection circuit breaker (see type table) for

- effective motor protection. Motors without thermal contacts must be protected by means of on-site a motor protection circuit breaker.
- **Electrical connection**
 Standard terminal box (IP55) on back of motor. Additionally on outside of duct for HRF types. Different for explosion-proof types.
- **Protection grille**
 Made of powder-coated steel for HQ and HW (HQ.. Ex galvanised). In accordance with DIN EN ISO 13857.
- **Power control**
 The voltage-controllable types are identified in the "Current consumption max. with control" column with a value which must be observed when determining the controller (see speed controller column). Possible assignments of frequency inverters to fans are shown in the type

- table. The planned use of a frequency inverter without a sine filter should be indicated when placing the order. This requires a change of fan version and additional costs, if necessary. The flow rates are shown in the performance diagram.
- **Reverse operation**
 All types are reversible using a reverser switch. Performance reduction of approx. 1/3 in abnormal flow direction.
- **Installation**
 Installation possible in any position, but be aware of any condensate drain holes depending on usage.
- **Dimensions**
 Pole-changeable and explosion-proof types may differ from the above information.

- **Noise levels**
 See performance diagram. The sound power and sound pressure at 4 m distance under free field conditions are specified for the average operating point on the inlet/outlet side. See page 14 f for noise emissions and room acoustics. Different for explosion-proof types.
- | Reference | Page |
|----------------------|--------|
| Techn. description | 180 |
| Selection table | 181 |
| Planning information | 14 ff. |
- Special design**
 Different voltage, protection category, air flow direction, higher air flow temperature, acid protection and impeller in other materials upon request.
- The technical information on p. 19 ff. must be observed.

Speed	Flow rate free-blowing	Power consump.	Current consump.		Wiring diagram	Max. air flow temp.		Weight net appr.	Design type						
			at rated voltage	max. with control		at rated voltage	with control		HQ incl. protection grille	Ref. no.	HW incl. protection grille	Ref. no.	HRF	Ref. no.	Dim. B Motor protrusion in mm
min ⁻¹	V m ³ /h	W	A	A	No.	+ °C	+ °C	kg							
Single-phase alternating current, 230 Volt, 50 Hz, Capacitor motor, protection category IP55															
950	10530	0.44	2.16	3.20	475	60	40	28.0	HQW 630/6	05037	—	—	—	—	—
1325	16210	1.50*	8.40*	7.00	964	40	—	40.0	HQW 630/4	05056	—	—	HRFW 630/4	05057	30
Three-phase current, 400 Volt, 50 Hz, Squirrel-cage rotor, protection category IP55															
710	7810	0.20	0.66	0.70	469	40	40	27.0	HQD 630/8	05029	—	—	—	—	—
960	10560	0.44	1.22	—	469	60	40	30.5	HQD 630/6	05027	HWD 630/6	01032	HRFD 630/6	00244	—
Two-speed, three-phase current, 400 V, 50 Hz, ∇/Δ connection, protection category IP55															
1170/1390	14310/17000	0.90/1.57	2.3/3.8	—	520	40	—	37.5	HQD 630/4/4	05030	HWD 630/4/4	01033	HRFD 630/4/4	00245	—
Pole-changeable, 2 speeds, three-phase current, Dahlander winding, 400 Volt, 50 Hz, protection category IP55															
440/935	5290/10470	0.14/0.43	0.60/1.13	—	472	60	—	41.0	HQD 630/12/6	05031	—	—	HRFD 630/12/6	00410	—
690/1400	7990/15990	0.37/1.50*	1.33/3.70*	—	471	40	—	40.5	HQD 630/8/4	05032	—	—	HRFD 630/8/4	00411	—
 Ex Explosion-proof, II 2G Ex h IIB + H₂ T3 Gb, Motor Ex e, three-phase current 400 Volt, 50 Hz, protection category IP55															
945	10480	0.55*	1.60*	—	470	40	—	30.0	HQD 630/6 Ex	05035	—	—	HRFD 630/6 Ex	00494	—
1440	17730	1.50*	3.40*	—	470	40	—	35.0	HQD 630/4 Ex	05036	—	—	HRFD 630/4 Ex	00495	—

* For Ex types: Motor ratings see information on page 20. ¹⁾ Incl. motor protection circuit breaker. ²⁾ Flush-m. version see Switch product page.

Performance curves 630/4

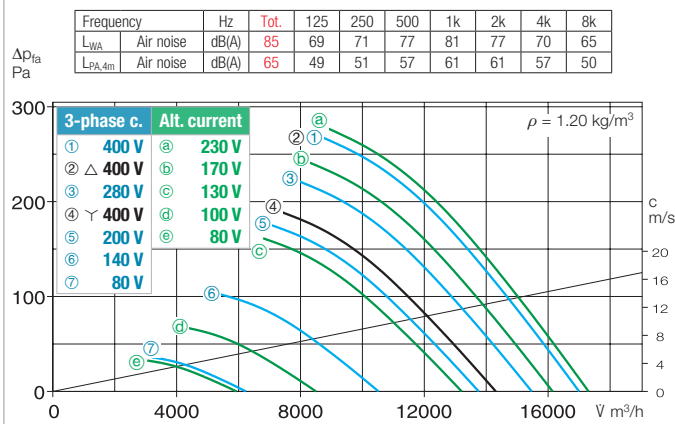

Performance curves 630/6

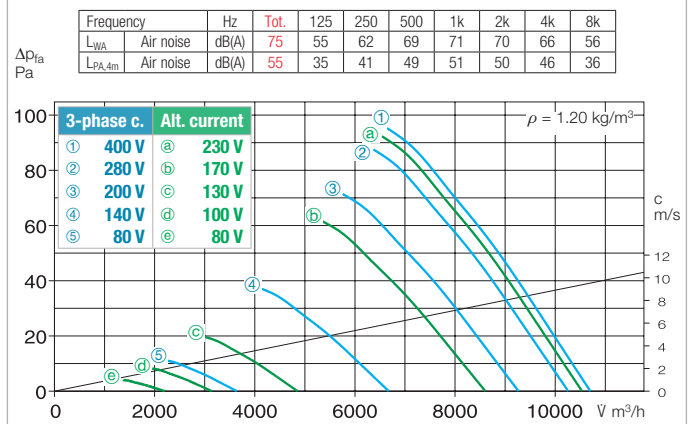

Performance curves 630/8

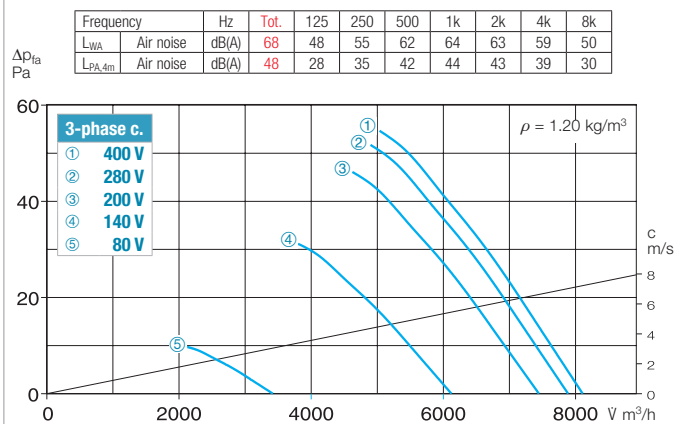

Performance curve 630/12

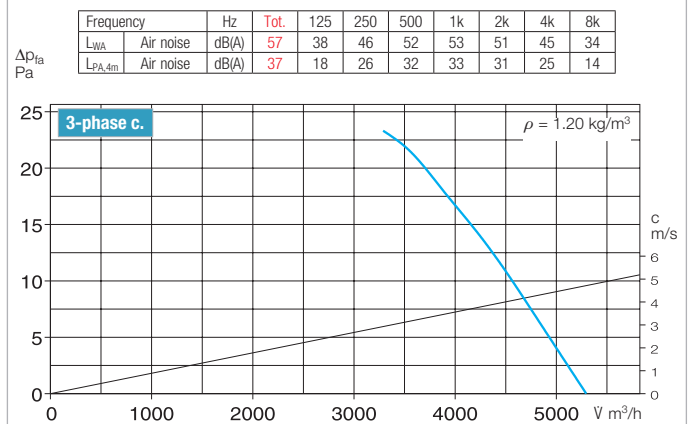

Accessories for HRF 630 Description see page 276 ff.

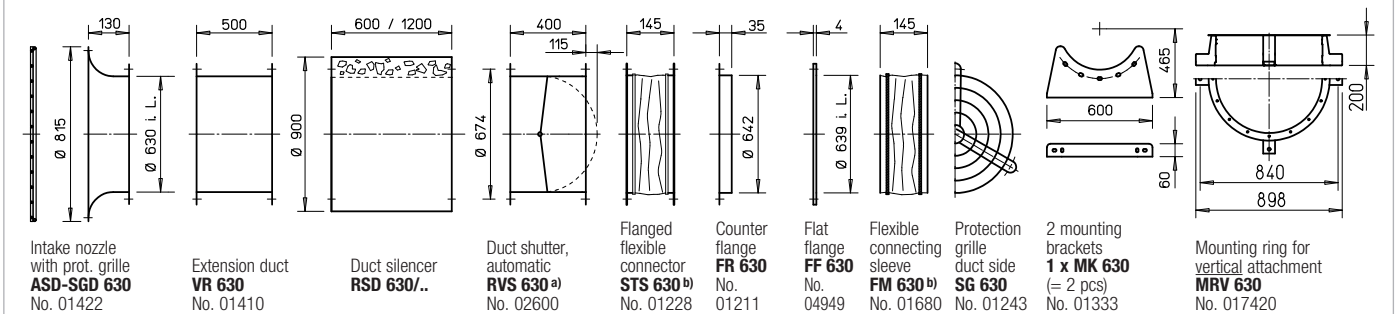

^{a)} Shutter, motorised see Accessories product pages.

^{b)} See below for types for explosion-proof fans.

Frequency inverter with integrated sine filter		Transformer speed controller 5-step, pole changing switch		Electronic speed controller, continuously variable flush-m./surface-m.		Motor protection circuit breaker for connecting built-in thermal contacts		Reverser switch	
Type	Ref. no.	Type	Ref. no.	Type	Ref. no.	Type	Ref. no.	Type	Ref. no.
—	—	MWS 3¹⁾	01948	ESU 5/ESA 5	01296/01299	MW	01579	WS	01271
—	—	MWS 7.5¹⁾	01950	—	—	MW	01579	WS	01271
FU-BS 2.5¹⁾	05459	RDS 2¹⁾	01315	ESD 5¹⁾	00501	MD	05849	WS	01271
FU-BS 2.5¹⁾	05459	RDS 2¹⁾	01315	ESD 5¹⁾	00501	MD	05849	WS	01271
FU-BS 5.0¹⁾	05460	RDS 4¹⁾	01316	ESD 5¹⁾	00501	M 4³⁾	01571	WS	01271
—	—	Pole changing switch		—	—	M 3³⁾	01293	PWDA	01282
—	—	PDA 12²⁾	05081	—	—	M 3³⁾	01293	PWDA	01282
—	—	PDA 12²⁾	05081	—	—	—	—	—	—
—	—	not permitted	—	not permitted	—	—	—	—	—
—	—	not permitted	—	not permitted	—	—	—	—	—

³⁾ Incl. speed pole changing switch.

Other accessories Page

^{b)} Access. for expl.-proof fans	
Flanged flexible connector STS 630 Ex	Ref. no. 02509
Silencers	494 ff.
Shutters and ventilation grilles	561 ff.
Speed controllers, controllers and switches	599 ff.
Flexible connecting sleeve FM 630 Ex	Ref. no. 01696

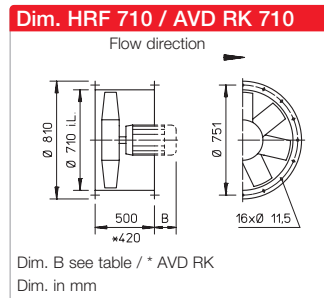
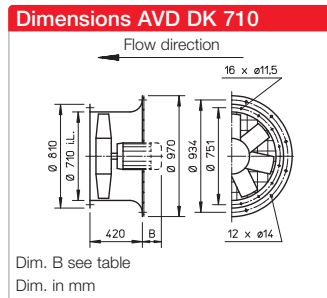
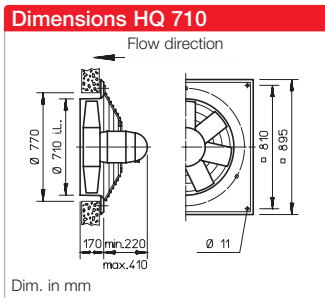

Description for all types

- Casing**
With motor mount made of galvanised steel sheet.
- Impeller**
High performance characteristics with profiled blades made of plastic, dynamically balanced. Different for explosion-proof types.
- Angle of attack**
The impeller blades can be adjusted for optimal operating point coverage (except for explosion-proof types and type HQW 710/6). The angle of attack is adjusted (according to the order) and fixed at the factory.

- The motor is assigned using the maximum power according to the information in the table below. The specified angle of attack must not be exceeded.
- Drive**
Closed design type IP55 or IP54. Maintenance-free and radio interference-free. Tropicalised winding with moisture proof coating. Different for explosion-proof types.
- Motor protection**
All types (except for pole-changeable and explosion-proof types, see page 180) are equipped with thermal contacts or PTC thermistors and must be protected by means of the following

- motor protection devices according to the footnotes the table:
¹MW/MD, Ref. no. 01579/05849
²MSA, Ref. no. 01289 (for PTC thermistor temperature sensor)
³M 4, Ref. no. 01571
All other types must be protected by means of on-site a motor protection circuit breaker.
- Protection grille**
Hot-dip galvanised or powder-coated for HQ and AVD DK as standard in accordance with DIN EN ISO 13857.
- Electrical connection**
Terminal box in protection category IP54 mounted on motor. Additionally on outside of duct

for HRF types. Different for explosion-proof types.

- Power control**
Partly through voltage reduction, see "Transformer speed con-troller" column. Regulated performance performance curve upon request.
Frequency inverter possible for all types (except for pole-changeable and explosion-proof types). The planned use of a frequency inverter without a sine filter should be indicated when placing the order. This requires a change of fan version and additional costs, if necessary.
- Reverse operation**
All types are reversible using a reverser switch. Performance reduction of approx. 1/3 in abnormal flow direction.

- Installation**
Installation possible in any position, but be aware of any condensate drain holes depending on usage.
- Dimensions**
Pole-changeable and explosion-proof types may differ from the above information. Motor lengths may vary. Take note of dim. B protrusion.
- Noise levels**
The sound power values over the frequency and as total levels are indicated above the performance diagrams.
Different for explosion-proof types.

Speed min ⁻¹	Flow rate free blowing V m ³ /h	Rated motor power (output)* kW	Voltage V	Current consump. Rat. volt./ (control)* A	Max. position ° deg.	Wiring dia- gram No.	Max. air flow temp. + °C	Wgt net appr.** kg	Design type				Transformer speed controller 5-step, pole changing switch					
									HQ incl. protection grille	Ref. no.	AVD DK incl. protection grille	Ref. no. Dim. B Motor protr. in mm	HRFD AVD RK	Ref. no. Dim. B Motor protr. in mm	Type	Ref. no.		
Single-phase alternating current. 230 Volt, 50 Hz, Capacitor motor, protection category IP55																		
910	14200	0.60	230	2.6	25	965	40	40.0	HQW 710/6 ¹⁾	05047	—	—	—	MWS 5 ⁴⁾	01949			
Three-phase current, 400 Volt, 50 Hz, Squirrel-cage rotor, protection category IP45																		
690	13330	0.29	400	0.9	20	469	40	57.0	HQD 710/8 ¹⁾	05599	AVD DK 710/8 ¹⁾	05251	—	HRFD 710/8 ¹⁾	06930	RDS 2 ⁴⁾	01315	
940	15560/19170	1.1*	230/400	5.1*	35	776	40	60.0	HQD 710/6 ¹⁾	05603	AVD DK 710/6 ¹⁾	05255	145	HRFD 710/6 ¹⁾	06934	10	TS D 7	01504
1445	26420	3.00*	400/690	6.2*	30	776	40	88.0	HQD 710/4 ²⁾	05606	AVD DK 710/4 ²⁾	05258	175	HRFD 710/4 ²⁾	06937	35	TS D 11	01513
Two-speed, three-phase current, 400 V, 50 Hz, protection category IP55																		
730/890	13550/16090	0.4/0.75*	400/400	1.1/2.3*	25	520	40	55.0	HQD 710/6/6 ³⁾	05602	AVD DK 710/6/6 ³⁾	05254	120	HRFD 710/6/6 ³⁾	06933	5	RDS 4 ⁴⁾	01316
1120/1360	16140/19670	0.95/1.55*	400/400	2.4/4.2*	20	520	40	60.0	HQD 710/4/4 ³⁾	05604	AVD DK 710/4/4 ³⁾	05256	145	HRFD 710/4/4 ³⁾	06935	—	RDS 7 ⁴⁾	01578
1030/1340	19370/23280	1.5/2.2*	400/400	3.0/5.2*	26	520	40	75.0	HQD 710/4/4 ³⁾	05605	AVD DK 710/4/4 ³⁾	05257	170	HRFD 710/4/4 ³⁾	06936	35	RDS 7 ⁴⁾	01578
Pole-changeable, 2 speeds, three-phase current, Dahlander winding, 400 Volt, 50 Hz, protection category IP45																		
685/1430	10810/22090	0.5/2.0*	400/400	2.0/4.7	23	471	40	82.0	HQD 710/8/4/..	05611	AVD DK 710/8/4/..	05263	160	HRFD 710/8/4/..	06942	20	PDA 12 ⁵⁾	05081
720/1440	14155/26200	0.9/3.6*	400/400	2.9/8.3	30	471	40	108.0	HQD 710/8/4/..	05612	AVD DK 710/8/4/..	05264	175	AVD RK 710/8/4/..	06943	90	PDA 12 ⁵⁾	05081
Explosion-proof, II 2G Ex h IIB + H₂ T3 Gb, Motor Ex e, three-phase current 400 Volt, 50 Hz, protection category IP55																		
695	13270	0.55*	400	2.2*	35	470	40	68.0	HQD 710/8 Ex	05618	AVD DK 710/8 Ex	05270	105	HRFD 710/8 Ex	06948	—	not permitted	
945	13480	0.55*	400	1.6*	25	470	40	67.0	HQD 710/6 Ex	05620	AVD DK 710/6 Ex	05272	105	HRFD 710/6 Ex	06949	—	not permitted	
960	16770	0.95*	400	2.7*	35	470	40	77.0	HQD 710/6 Ex	05621	AVD DK 710/6 Ex	05273	155	HRFD 710/6 Ex	06950	—	not permitted	
1435	20540	2.20*	400	4.9*	25	470	40	82.0	HQD 710/4 Ex	05623	AVD DK 710/4 Ex	05275	175	AVD RK 710/4 Ex	06951	90	not permitted	
1455	26160	4.00*	400/690	8.3*	35	498	40	102.0	HQD 710/4 Ex	05624	AVD DK 710/4 Ex	05276	190	AVD RK 710/4 Ex	06952	105	not permitted	

* Motor ratings, Ex see information p. 20. ¹⁾ up to ³⁾ Motor protection devices, see description "Motor protection". ** Weights apply for type ..DK and ..RK, HRF and HQ minus approx. 15 kg. ⁴⁾ Incl. motor protection circuit breaker 1.2/2.2 kW.

Performance curves 710/4

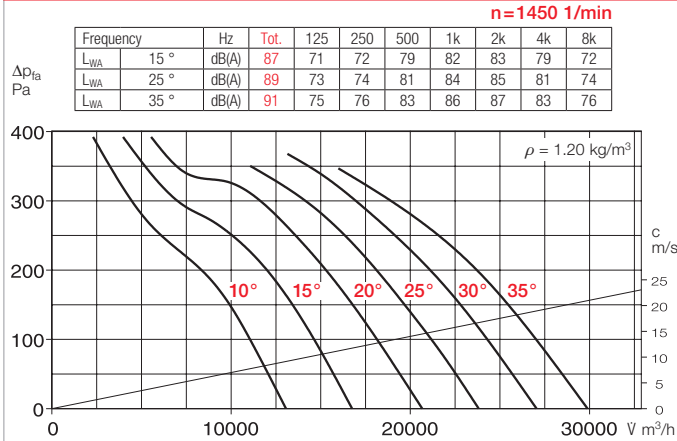

Performance curves 710/6 – Alternating current

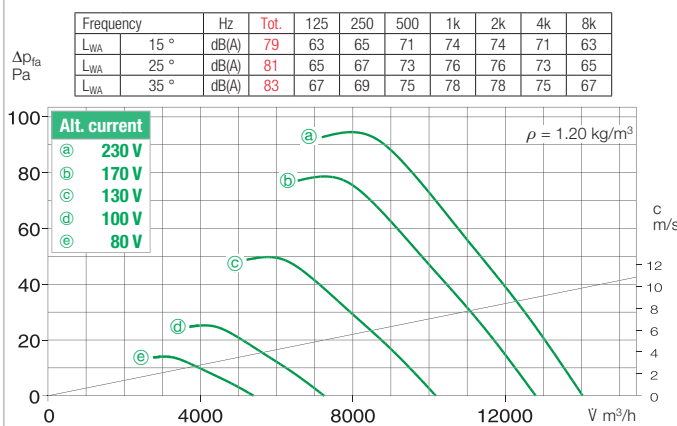

Performance curves 710/6 – Three-phase current

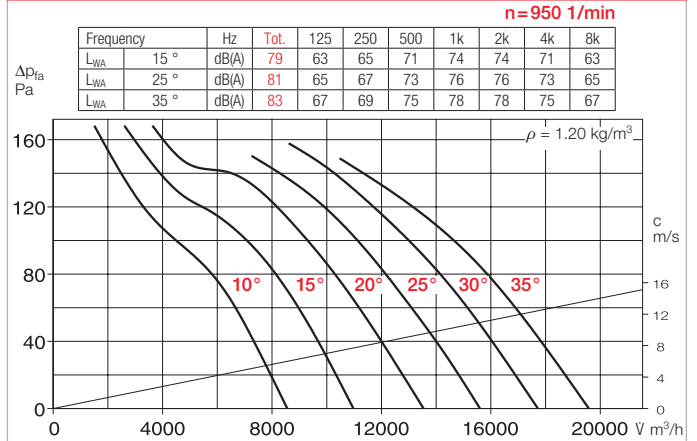

Performance curves 710/8

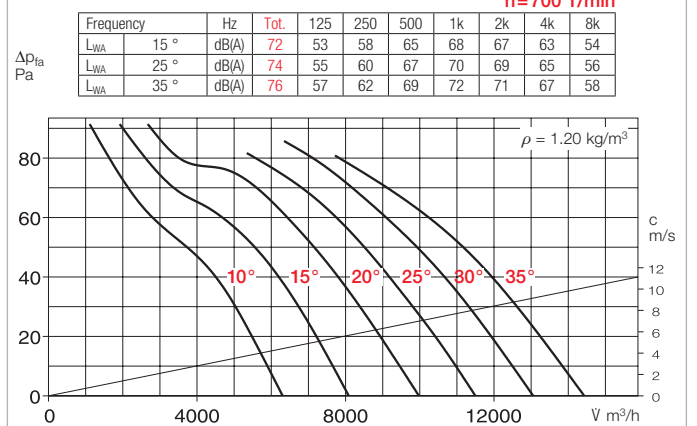

Axial and VAR fans

Accessories for HRF 710 / AVD RK 710 Description see page 276 ff.

Elec. speed controller, continuously variable Frequency inverter with sine filter		Vibration damper Nominal size	
Type	Ref. no.	Type	Ref. no.
—	—	..1/.1	01452/01454
EDS 5 ⁴⁾	00501	..1/.1	01452/01454
FU-BS 8.0 ⁴⁾	05461	..1/.1	01452/01454
FU-BS 8.0 ⁴⁾	05461	..2/.2	01453/01455
EDS 5 ⁴⁾	00501	..1/.1	01452/01454
EDS 5 ⁴⁾	00501	..1/.1	01452/01454
EDS 11.5 ⁴⁾	00502	..2/.2	01453/01455
—	—	..2/.2	01453/01455
—	—	..2/.2	01453/01455
not permitted	..1/.2	01452/01455	
not permitted	..1/.2	01452/01455	
not permitted	..1/.2	01452/01455	
not permitted	..2/.2	01453/01455	
not permitted	..2/.2	01453/01455	

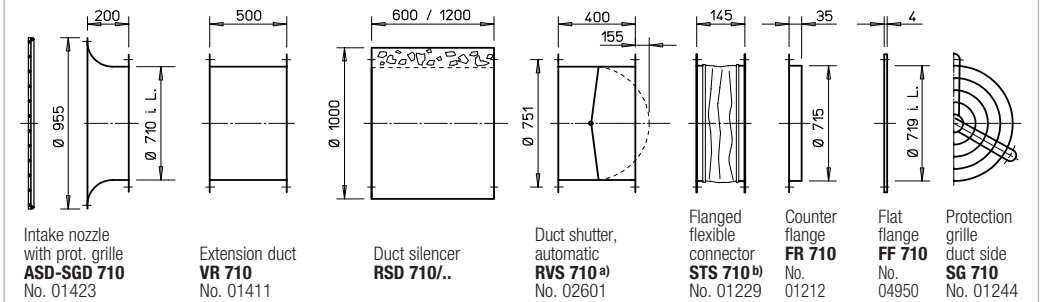

^{a)} Shutter, motorised see Accessories product pages.

^{b)} See below for types for explosion-proof fans.

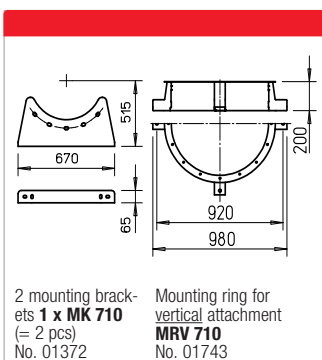

Reference	Page
Techn. description	180
Selection table	181
Planning information	14 ff.

Special design

Different voltage, protection category, air flow temperature, acid protection and impeller made of cast aluminium upon request.

Other accessories	Page
^{b)} Access. for expl.-proof fans	
Flanged flexible connector STS 710 Ex	Ref. no. 02510
Silencers	494 ff.
Shutters and ventilation grilles	561 ff.
Speed controllers, controllers and switches	599 ff.

⁵⁾ Flush-m. version see Switch product page.

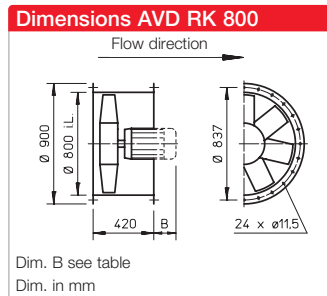
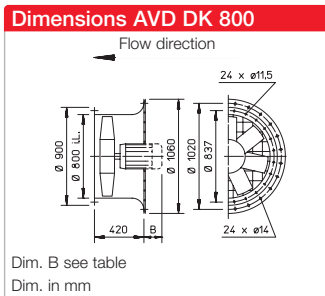

Description for all types

- **Casing**
With motor mount made of galvanized steel sheet.
- **Impeller**
High performance characteristics with profiled blades made of plastic, dynamically balanced. Different for explosion-proof types.
- **Angle of attack**
The impeller blades can be adjusted for optimal operating point coverage (except for explosion-proof types). The angle of attack is adjusted (according to the order) and fixed at the factory. The motor is assigned using the maximum power according to the information in the table below. The specified angle of attack must not be exceeded.

- **Drive**
Closed design type IP55 or IP54. Maintenance-free and radio interference-free. Tropicalised winding with moisture proof coating. Different for explosion-proof types.
- **Motor protection**
All types (except for pole-changeable and explosion-proof types, see page 180) are equipped with thermal contacts or PTC thermistors and must be protected by means of the following motor protection devices according to the footnotes the table:
⁴⁾MSA, Ref. no. 01289 (for PTC thermistor temperature sensor)
⁵⁾M 4, Ref. no. 01571
All other types must be protected by means of on-site a motor protection circuit breaker.

- **Electrical connection**
Terminal box in protection category IP54 mounted on motor.
- **Protection grille**
Hot-dip galvanised for AVD DK as standard in accordance with DIN EN ISO 13857.
- **Power control**
Partly through voltage reduction, see "Transformer speed controller" column. Regulated performance performance curve upon request. Frequency inverter possible for all types (except for pole-changeable and explosion-proof types). The planned use of a frequency inverter without a sine filter should be indicated when placing the order. This requires a change of fan version and additional costs, if necessary.

- **Reverse operation**
All types are reversible using a reverser switch. Performance reduction of approx. 1/3 in abnormal flow direction.
- **Installation**
Installation possible in any position, but be aware of any condensate drain holes depending on usage.
- **Dimensions**
Pole-changeable and explosion-proof types may differ from the above information. Motor lengths may vary. Take note of dim. B protrusion.
- **Noise levels**
The sound power values over the frequency and as total levels are indicated above the performance diagrams. Different for explosion-proof types.

Speed min ⁻¹	Flow rate free blowing V m ³ /h	Rated motor power (output)* kW	Voltage V	Current consump. Rat. volt./ (control)* A	Max. position ° deg.	Wiring dia- gram No.	Max. air flow temp. + °C	Wgt net aprx.** kg	Design type							
									AVD DK incl. protection grille	Ref. no.	Dim. B Motor protr. in mm	AVD RK	Ref. no.	Dim. B Motor protr. in mm	Transformer speed controller 5-step, pole changing switch	Type
Three-phase current, 50 Hz, Squirrel-cage rotor, protection category IP54																
1445	33450	4.00*	400/690	8.3*	26	776	40	101	AVD DK 800/4/.. ⁴⁾	05311	210	AVD RK 800/4/.. ⁴⁾	06960	210	—	
1450	39130	5.5*	400/690	11*	33	776	40	115	AVD DK 800/4/.. ⁴⁾	05312	290	AVD RK 800/4/.. ⁴⁾	06961	290	—	
Two-speed, three-phase current, 400 V, 50 Hz, protection category IP55																
775/920	15720/18670	0.40/0.75*	400/400	1.1/2.3*	22	520	40	70	AVD DK 800/6/6.. ⁵⁾	05307	125	AVD RK 800/6/6.. ⁵⁾	06956	125	RDS 4 ²⁾	01316
Pole-changeable, 2 speeds, three-phase current, 50 Hz, protection category IP54																
695/1400	10020/20180	0.37/1.50*	400/400	1.3/3.7*	12	471	40	95	AVD DK 800/8/4.. ¹⁾	05319	135	AVD RK 800/8/4/.. ¹⁾	06968	135	PDA 12 ³⁾	05081
Explosion-proof, II 2G Ex h IIB + H₂ T3 Gb, Motor Ex e, three-phase current 400 Volt, 50 Hz, protection category IP55																
695	17190	0.55*	400	2.2*	32	470	40	81	AVD DK 800/8 Ex/..	05326	140	AVD RK 800/8 Ex/..	06974	140	not permitted	
960	20340	0.95*	400	2.7*	23	470	40	90	AVD DK 800/6 Ex/..	05329	105	AVD RK 800/6 Ex/..	06976	105	not permitted	
965	26710	1.9*	400	5.1*	35	470	40	132	AVD DK 800/6 Ex/..	05330	165	AVD RK 800/6 Ex/..	06977	255	not permitted	
1455	31900	4.00*	400/690	8.3*	24	498	40	115	AVD DK 800/4 Ex/..	05332	210	AVD RK 800/4 Ex/..	06978	210	not permitted	
1450	36820	5.00*	400/690	10.1*	30	498	40	143	AVD DK 800/4 Ex/..	05333	290	AVD RK 800/4 Ex/..	06979	290	not permitted	

* Motor ratings, Ex see information p. 20.

¹⁾ Dahlander winding.

²⁾ Incl motor protection circuit breaker.

³⁾ Flush-m. version see Switch product page.

⁴⁾ and ⁵⁾ Motor protection devices, see description "Motor protection".

Performance curves 800/4

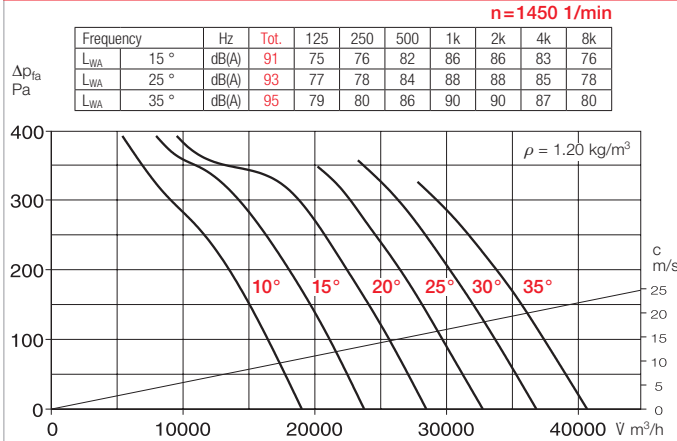

Performance curves 800/6

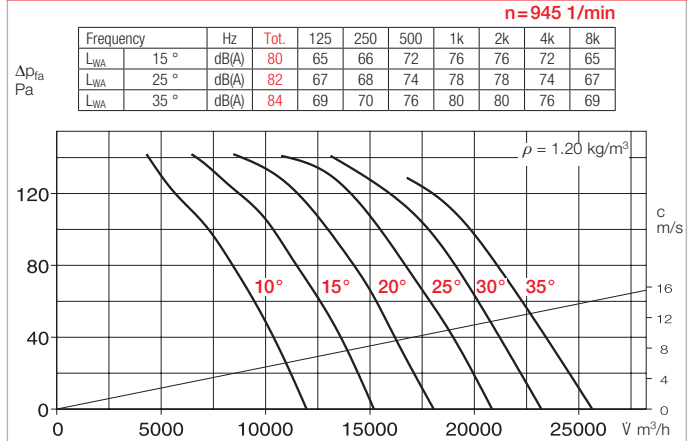

Performance curves 800/8

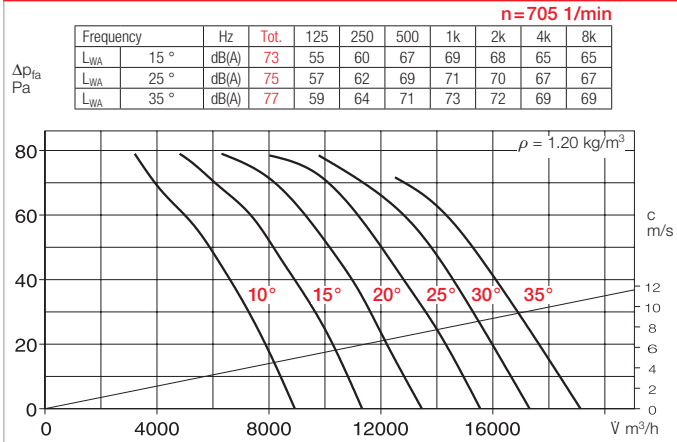

Accessories for AVD RK 800 Description see page 276 ff.

Intake nozzle with prot. grille ASD-SGD 800 No. 01424	Extension duct VR 800 No. 01412	Duct silencer RSD 800/..	Duct shutter, automatic RVS 800 a) No. 02602	Flanged flexible connector STS 800 b) No. 01233	Counter flange FR 800 No. 01198	Flat flange FF 800 No. 04951	Protection grille duct side SG 800 No. 01245	2 mounting brackets 1 x MK 800 (= 2 pcs) No. 01373	Mounting ring for vertical attachment MRV 800 No. 01744
--	--	------------------------------------	---	--	--	---	---	--	--

a) Shutter, motorised see Accessories product pages.

b) See below for types for explosion-proof fans.

Elec. speed controller, continuously variable Frequency inverter with sine filter		Vibration damper Nominal size SDD/SDZ	
Type	Ref. no.	Type	Ref. no.
FU-BS 10 ^{a)}	05462	..2/..2	01453/01455
FU-BS 14 ^{a)}	05463	—	—
EDS 5 ^{a)}	00501	..2/..2	01453/01455
—	—	..2/..2	01453/01455
not permitted	—	..2/..2	01453/01455
not permitted	—	..2/..2	01453/01455
not permitted	—	..2/..2	01453/01455
not permitted	—	..2/..2	01453/01455
not permitted	—	..2/..2	01453/01455

Reference	Page
Techn. description	180
Selection table	181
Planning information	14 ff.
Special design	
Different voltage, protection category, air flow direction, higher air flow temperature, acid protection and impeller made of cast aluminium upon request.	
The technical information on p. 19 ff. must be observed.	

Other accessories	Page
b) Access. for expl.-proof fans	
Flanged flexible connector STS 800 Ex	Ref. no. 02511
Silencers	494 ff.
Shutters and ventilation grilles	561 ff.
Speed controllers, controllers and switches	599 ff.

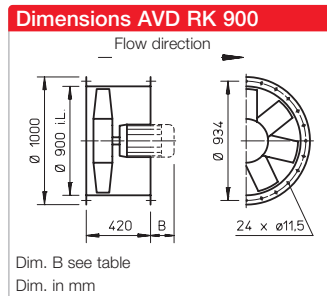
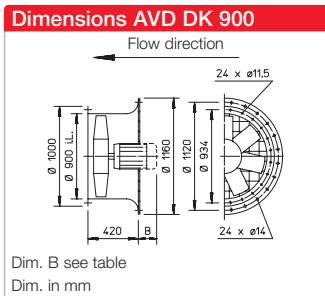

Description for all types

- **Casing**
 With motor mount made of galvanized steel sheet.
- **Impeller**
 High performance characteristics with profiled blades made of plastic, dynamically balanced. Different for explosion-proof types.
- **Angle of attack**
 The impeller blades can be adjusted for optimal operating point coverage (except for explosion-proof types). The angle of attack is adjusted (according to the order) and fixed at the factory. The motor is assigned using the maximum power according to the information in the table below. The specified angle of attack must not be exceeded.

- **Drive**
 Closed design type IP55 or IP54. Maintenance-free and radio interference-free. Tropicalised winding with moisture proof coating. Different for explosion-proof types.
- **Motor protection**
 All types (Ref. no. 05380 Ref. no. 06996 and explosion-proof, see page 180) are equipped with thermal contacts or PTC thermistors and must be protected by means of the following motor protection devices according to the footnotes the table:
⁴⁾MSA, Ref. no. 01289 (for PTC thermistor temperature sensor)
⁵⁾M 4, Ref. no. 01571
 All other types must be protected by means of on-site motor protection circuit breaker.

- **Electrical connection**
 Terminal box in protection category IP54 mounted on motor.
- **Protection grille**
 Hot-dip galvanised for AVD DK as standard in accordance with DIN EN ISO 13857.
- **Power control**
 Partly through voltage reduction, see "Transformer speed controller" column. Regulated performance performance curve upon request. Frequency inverter possible for all types (except for pole-changeable and explosion-proof types). The planned use of a frequency inverter without a sine filter should be indicated when placing the order. This requires a change of fan version and additional costs, if necessary.

- **Reverse operation**
 All types are reversible using a reverser switch. Performance reduction of approx. 1/3 in abnormal flow direction.
- **Installation**
 Installation possible in any position, but be aware of any condensate drain holes depending on usage.
- **Dimensions**
 Pole-changeable and explosion-proof types may differ from the above information. Motor lengths may vary. Take note of dim. B protrusion.
- **Noise levels**
 The sound power values over the frequency and as total levels are indicated above the performance diagrams. Different for explosion-proof types.

Speed	Flow rate free blowing	Rated motor power (output)*	Voltage	Current consump. Rat. volt./ (control)*	Max. position	Wiring dia-gram	Max. air flow temp.	Wgt net appr.**	Design type						
									AVD DK incl. protection grille		AVD RK		Transformer speed controller 5-step, pole changing switch		
min ⁻¹	V m ³ /h	kW	V	A	° deg.	No.	+ °C	kg	Ref. no.	Dim. B Motor prot. in mm	Ref. no.	Dim. B Motor prot. in mm	Type	Ref. no.	
Three-phase current, 50 Hz, Squirrel-cage rotor, protection category IP54															
950	37300	3.00*	400/690	6.2*	34	776	40	130	AVD DK 900/6/.. ⁴⁾	05369	290	AVD RK 900/6/.. ⁴⁾	06985	290	—
1445	35030	4.00*	400/690	8.3*	16	776	40	118	AVD DK 900/4/.. ⁴⁾	05370	210	AVD RK 900/4/.. ⁴⁾	06986	210	—
1450	48995	7.50*	400/690	14.5*	27	776	40	142	AVD DK 900/4/.. ⁴⁾	05371	325	AVD RK 900/4/.. ⁴⁾	06987	325	—
1470	57720	11.00*	400/690	20.0*	34	776	40	186	AVD DK 900/4/.. ⁴⁾	05372	385	AVD RK 900/4/.. ⁴⁾	06988	385	—
Two-speed, three-phase current, 400 V, 50 Hz, √3 connection, protection category IP55															
775/930	18390/22660	0.71/1.32*	400/400	2.1/4.0*	19	520	40	90	AVD DK 900/6/6.. ⁵⁾	05367	180	AVD RK 900/6/6.. ⁵⁾	06983	180	RDS 7 ²⁾ 01578
770/920	25990/31060	1.38/2.37*	400/400	3.9/7.1*	27	520	40	115	AVD DK 900/6/6.. ⁵⁾	05368	210	AVD RK 900/6/6.. ⁵⁾	06984	210	RDS 11 ²⁾ 01332
Pole-changeable, 2 speeds, three-phase current, 50 Hz, protection category IP54															
700/1435	18270/37450	1.10/4.50*	400/400	2.9/9.6*	18	471	40	120	AVD DK 900/8/4.. ¹⁾	05379	290	AVD RK 900/8/4.. ¹⁾	06995	290	PDA 12 ³⁾ 05081
715/1450	22390/45410	1.80/6.50*	400/400	5.7/14.5*	24	471	40	148	AVD DK 900/8/4.. ¹⁾	05380	325	AVD RK 900/8/4.. ¹⁾	06996	325	PDA 25 ³⁾ 05060
Explosion-proof, II 2G Ex h IIB + H₂ T₃ Gb, Motor Ex e, three-phase current 400 Volt, 50 Hz, protection category IP55															
700	24470	0.95*	400	2.8*	27	470	40	110	AVD DK 900/8 Ex/..	05386	180	AVD RK 900/8 Ex/..	06899	180	not permitted
725	28470	1.3*	400	3.9*	34	470	40	130	AVD DK 900/8 Ex/..	05387	210	AVD RK 900/8 Ex/..	06900	210	not permitted
965	30550	1.90*	400	5.1*	25	470	40	150	AVD DK 900/6 Ex/..	05389	165	AVD RK 900/6 Ex/..	06901	255	not permitted
960	38040	3.50*	400/690	7.4*	35	498	40	160	AVD DK 900/6 Ex/..	05390	290	AVD RK 900/6 Ex/..	06902	290	not permitted
1460	46630	6.80*	400/690	13.4*	25	498	40	175	AVD DK 900/4 Ex/..	05392	325	AVD RK 900/4 Ex/..	06903	325	not permitted
1465	55240	10.00*	400/690	19.8*	32	498	40	235	AVD DK 900/4 Ex/..	05393	385	AVD RK 900/4 Ex/..	06904	385	not permitted

* Motor ratings, see information p. 20. ¹⁾ Dahlander winding. ²⁾ Incl motor protection circuit breaker. ³⁾ Flush-m. version see Switch product page.
⁴⁾ and ⁵⁾ Motor protection devices, see description "Motor protection".

Performance curves 900/4

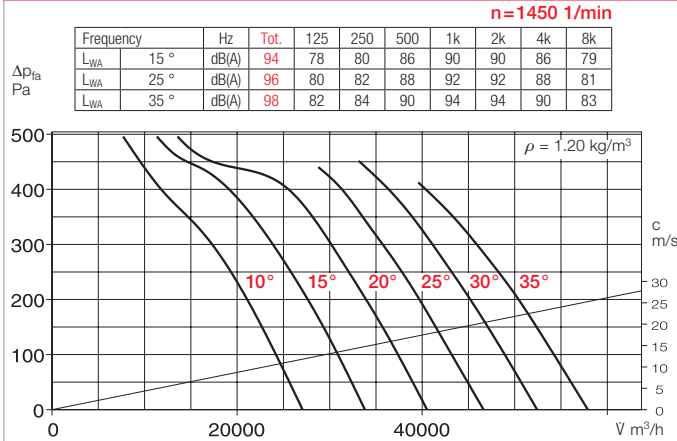

Performance curves 900/6

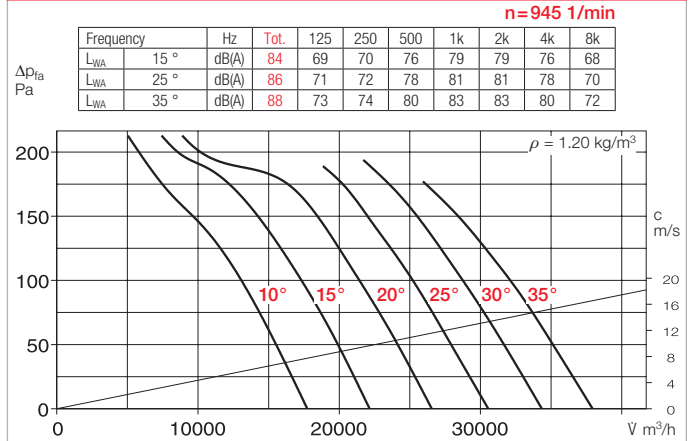

Performance curves 900/8

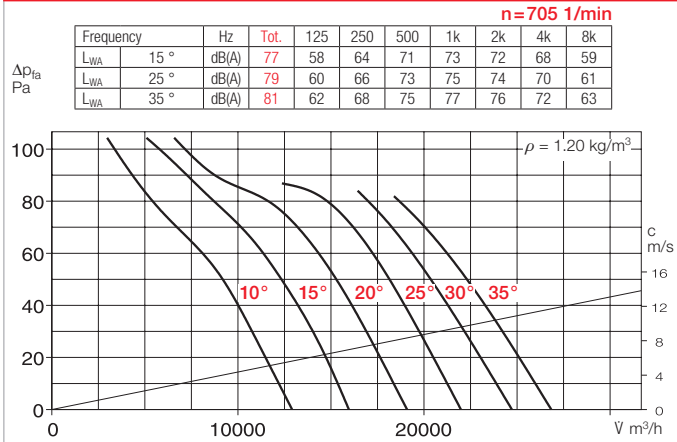

Axial and VAR fans

Accessories for AVD RK 900 Description see page 276 ff.

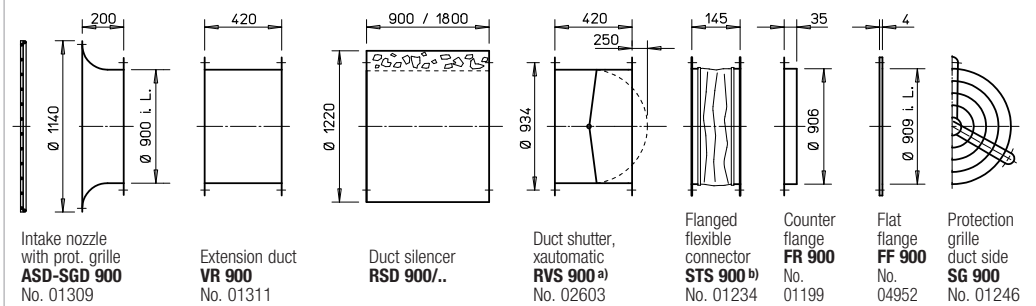

a) Shutter, motorised see Accessories product pages.

b) See below for types for explosion-proof fans.

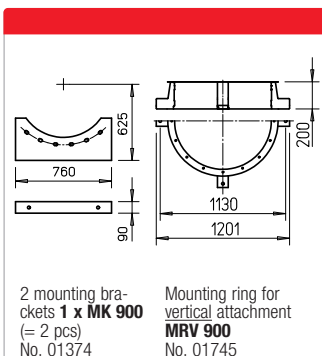

Reference	Page
Techn. description	180
Selection table	181
Planning information	14 ff.

Special design
Different voltage, protection category, air flow direction, higher air flow temperature, acid protection and impeller made of cast aluminium upon request.

Other accessories	Page
-------------------	------

b) **Access. for expl.-proof fans**

Flanged flexible connector STS 900 Ex Ref. no. 02512

Silencers 494 ff.

Shutters and ventilation grilles 561 ff.

Speed controllers, controllers and switches 599 ff.

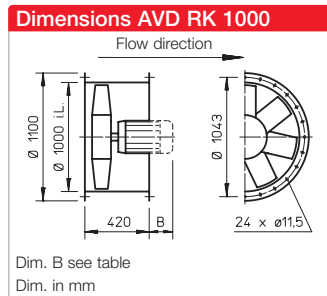
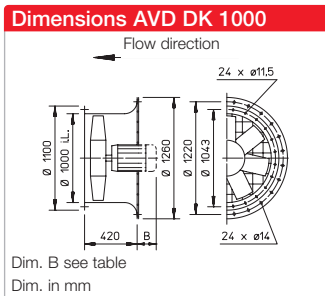

Description for all types

- **Casing**
 With motor mount made of galvanized steel sheet.
- **Impeller**
 High performance characteristics with profiled blades made of plastic, dynamically balanced. Different for explosion-proof types.
- **Angle of attack**
 The impeller blades can be adjusted for optimal operating point coverage (except for explosion-proof types). The angle of attack is adjusted (according to the order) and fixed at the factory. The motor is assigned using the maximum power according to the information in the table below. The specified angle of attack must not be exceeded.

- **Drive**
 Closed design type IP55 or IP54. Maintenance-free and radio interference-free. Tropicalised winding with moisture proof coating. Different for explosion-proof types.
- **Motor protection**
 All types (except for pole-changeable and explosion-proof types, see page 180) are equipped with thermal contacts or PTC thermistors and must be protected by means of the following motor protection devices according to the footnotes the table:
⁴⁾MSA, Ref. no. 01289 (for PTC thermistor temperature sensor)
⁵⁾M 4, Ref. no. 01571
 All other types must be protected by means of on-site a motor protection circuit breaker.

- **Electrical connection**
 Terminal box in protection category IP54 mounted on motor.
- **Protection grille**
 Hot-dip galvanised for AVD DK as standard in accordance with DIN EN ISO 13857.
- **Power control**
 Partly through voltage reduction, see "Transformer speed controller" column. Regulated performance performance curve upon request. Frequency inverter possible for all types (except for pole-changeable and explosion-proof types). The planned use of a frequency inverter without a sine filter should be indicated when placing the order. This requires a change of fan version and additional costs, if necessary.

- **Reverse operation**
 All types are reversible using a reverser switch. Performance reduction of approx. 1/3 in abnormal flow direction.
- **Installation**
 Installation possible in any position, but be aware of any condensate drain holes depending on usage.
- **Dimensions**
 Pole-changeable and explosion-proof types may differ from the above information. Motor lengths may vary. Take note of dim. B protrusion.
- **Noise levels**
 The sound power values over the frequency and as total levels are indicated above the performance diagrams. Different for explosion-proof types.

Speed min ⁻¹	Flow rate free blowing V m ³ /h	Rated motor power (output)* kW	Voltage V	Current consump. Rat. volt./ (control)* A	Max. position ° deg.	Wiring dia- gram No.	Max. air flow temp. + °C	Wgt net aprx.** kg	Design type				Transformer speed controller 5-step, pole changing switch Type Ref. no.			
									AVD DK incl. protection grille	Ref. no.	Dim. B Motor protr. in mm	AVD RK		Ref. no.	Dim. B Motor protr. in mm	
Three-phase current, 50 Hz, Squirrel-cage rotor, protection category IP54																
950	39720	3.0*	400/690	6.2*	23	776	40	120	AVD DK 1000/6/.. ⁴⁾	05398	290	AVD RK 1000/6/.. ⁴⁾	05573	290	—	—
955	46320	4.0*	400/690	9.2*	29	776	40	127	AVD DK 1000/6/.. ⁴⁾	05399	325	AVD RK 1000/6/.. ⁴⁾	05574	325	—	—
955	52450	5.5*	400/690	12.4*	35	776	40	145	AVD DK 1000/6/.. ⁴⁾	05400	325	AVD RK 1000/6/.. ⁴⁾	05575	325	—	—
1470	61460	11.0*	400/690	20.0*	23	776	40	160	AVD DK 1000/4/.. ⁴⁾	05401	385	AVD RK 1000/4/.. ⁴⁾	05576	385	—	—
1470	71290	15.0*	400/690	26.0*	29	776	40	195	AVD DK 1000/4/.. ⁴⁾	05402	430	AVD RK 1000/4/.. ⁴⁾	05577	430	—	—
1475	79440	18.5*	400/690	35.0*	34	776	40	210	AVD DK 1000/4/.. ⁴⁾	05403	465	AVD RK 1000/4/.. ⁴⁾	05578	465	—	—
Pole-changeable, 2 speeds, three-phase current, 50 Hz, protection category IP54													Pole changing switch			
715/1440	27410/55210	2.2/9.0*	400/400	7.2/19.0*	20	471	40	165	AVD DK 1000/8/4.. ¹⁾	05407	385	AVD RK 1000/8/4/.. ¹⁾	05582	385	PDA 25 ³⁾	05060
715/1445	32325/65330	3.0/12.0*	400/400	9.4/25.0*	26	471	40	190	AVD DK 1000/8/4.. ¹⁾	05408	415	AVD RK 1000/8/4/.. ¹⁾	05583	415	PDA 63 ³⁾	01283
Explosion-proof, II 2G Ex h IIB + H₂, T3 Gb, Motor Ex e, three-phase current 400 Volt, 50 Hz, protection category IP55																
955	43180	3.5*	400/690	7.4*	26	498	40	130	AVD DK 1000/6 Ex/..	05415	325	AVD RK 1000/6 Ex/..	05590	325	not permitted	—
960	52730	6.6*	400/690	13.4*	35	498	40	155	AVD DK 1000/6 Ex/..	05416	400	AVD RK 1000/6 Ex/..	05591	400	not permitted	—

* Motor ratings, see information p. 20. ¹⁾ Dahlander winding. ²⁾ Incl motor protection circuit breaker. ³⁾ Flush-m. version see Switch product page.
⁴⁾ and ⁵⁾ Motor protection devices, see description "Motor protection".

Performance curves 1000/4

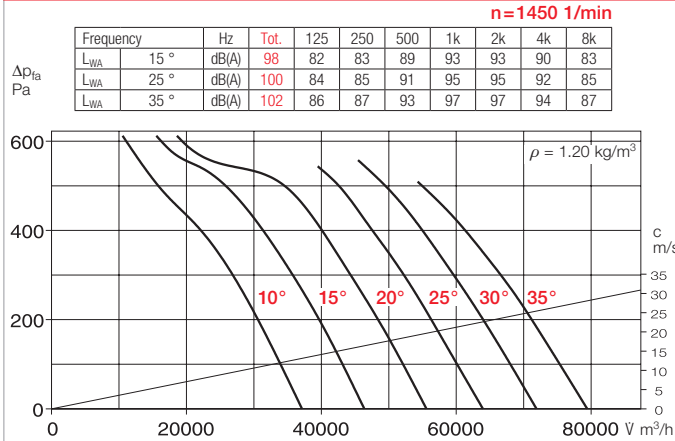

Performance curves 1000/6

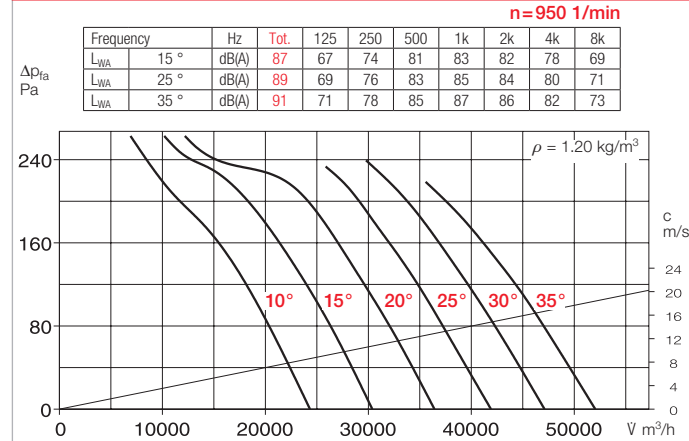

Performance curves 1000/8

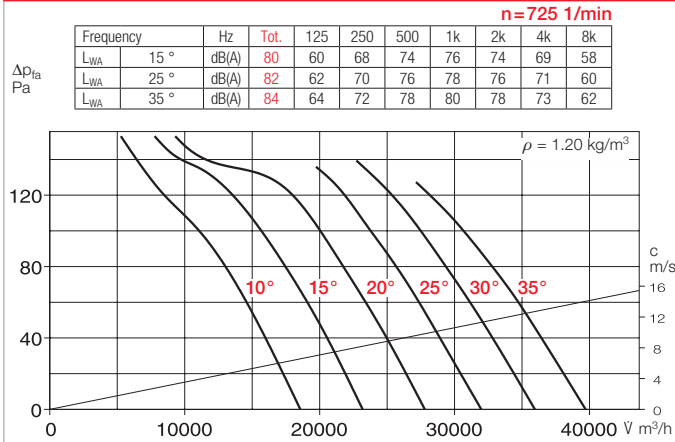

Accessories for AVD RK 1000 Description see page 276 ff.

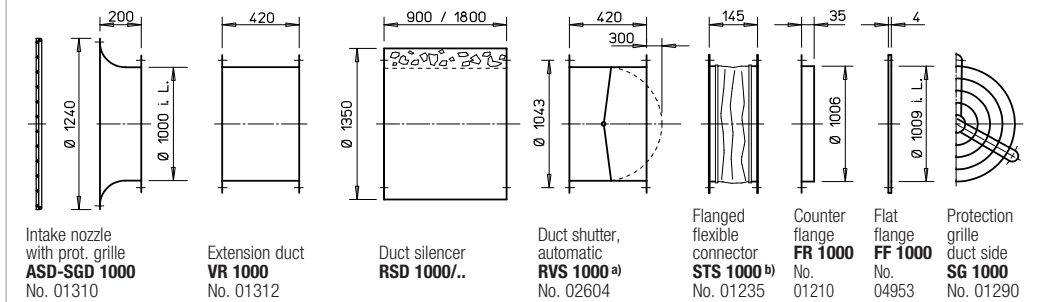

^{a)} Shutter, motorised see Accessories product pages.

^{b)} See below for types for explosion-proof fans.

Elec. speed controller, continuously variable Frequency inverter with sine filter		Vibration damper Nominal size	
Type	Ref. no.	Type	Ref. no.
FU-BS 8.0²⁾	05461	..2/..2	01453/01455
FU-BS 10.0²⁾	05462	..2/..2	01453/01455
FU-BS 10.0²⁾	05462	..2/..2	01453/01455
FU-CS 22²⁾	05470	..3/..3	01367/01366
FU-CS 32²⁾	05471	..3/..3	01367/01366
FU-CS 40²⁾	05472	..3/..3	01367/01366
—	—	..3/..3	01367/01366
—	—	..3/..3	01367/01366
not permitted	—	..2/..2	01453/01455
not permitted	—	..2/..2	01453/01455

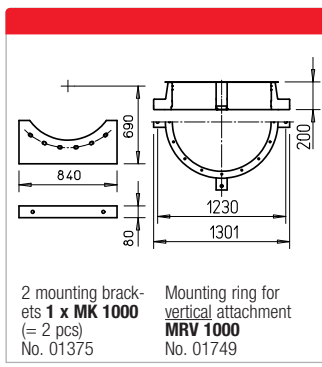

Reference	Page
Techn. description	180
Selection table	181
Planning information	14 ff.

Special design
 Different voltage, protection category, air flow direction, higher air flow temperature, acid protection and impeller made of cast aluminium upon request.

Other accessories	Page
^{b)} Access. for expl.-proof fans	
Flanged flexible connector STS 1000 Ex	Ref. no. 02513
Silencers	494 ff.
Shutters and ventilation grilles	561 ff.
Speed controllers, controllers and switches	599 ff.

Medium pressure axial fans. Maximum performance for a range of applications.

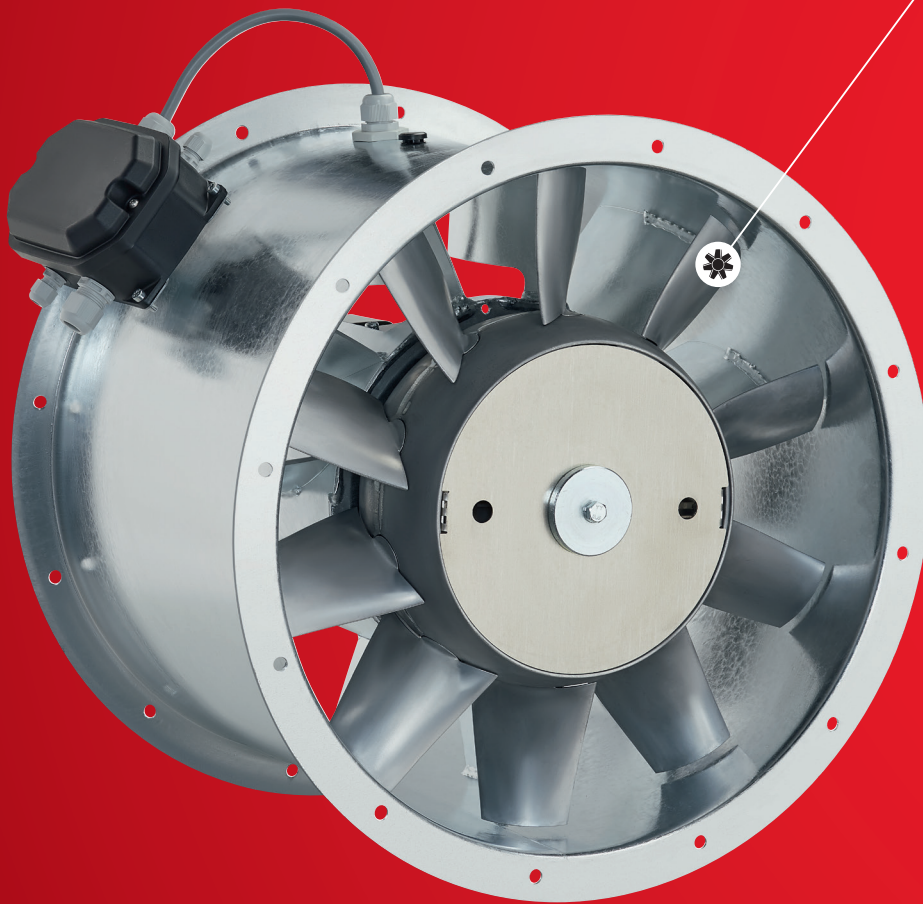

With diameter sizes from 225 to 630 mm, flow rates up to 32000 m³/h and very high pressure rates up to 1400 Pa, the Helios medium pressure axial fans provide for maximum volume flows in the smallest of spaces.

Universal installation options in horizontal and vertical positions allow flexible use in a variety of applications.



■ Innovative

Maximum efficiency is ensured by the new optimally tuned system consisting of a plastic impeller with perfectly integrated flow geometry, an innovative guide wheel with maximum pressure recovery and specially tuned motors. With AMD / AMW, we have created a product which meets the highest physical requirements.

■ Energy-efficient

- High pressure and volume rates with very small dimensions.
- Minimal noise levels.
- Minimal energy costs at maximum performance.
- Maximum pressure recovery due to innovative guide wheel.
- Very low residual torque.
- Low impact and outlet losses.

■ Universal

The complete AMD range with more than 300 types in 12 sizes (NS 315 – 1120) and V. > 113000 m³/h is included in the Helios TGA Catalogue. Includes B AMD types for mechanical smoke extraction systems (MRA) in temperature classes F300 and F400 as well as installation kits for two level serial Z or parallel P designs.

See TGA-catalogue
Ref. no. 86979



This information supplements the “General technical information”.

Features

AMD/AMW is a series of medium pressure fans in compact design with excellent power density in relation to its size. The new axial impeller, which has been optimised for pressure and efficiency, achieves the best levels of efficiency, high pressure levels and large flow rates in combination with the fixed guide wheel.

Casing

Tubular casing with flanges on both sides in accordance with DIN 24155 p. 3 with integrated guide wheel and motor mount made of galvanised steel. Terminal box on outside of duct.

Impeller

Axial impeller made of plastic with 14 spatially curved blades as well as perfectly integrated flow geometry in the impeller. Maximum pressure recovery in combination with the innovative guide wheel, high level of efficiency, low operating noise level, high corrosion resistance, low-vibration operation through dynamic balancing in accordance with DIN ISO 21940-11 – quality grade 6.3.

Air flow temperatures

The standard version can be used in the range from –30 up to at least +60 °C. See information on product page. Approval for higher continuous temperatures is possible upon request.

Air flow direction

The air flow direction cannot be changed, but it can be set by the installation method. The correct motor rotation direction and air flow direction is marked by arrows on the fan.

Installation position, installation, condensate outlets

A duct section with length = 2.5 x pipe diameter for free discharge and a corresponding straight duct section for intermediate positioning in a pipeline are required (Figure 1) to achieve the specified performance values. The ideal flow through the fan is only ensured if there is an upstream intake nozzle with sufficient intake space or a 2.5 x Ø long straight duct section in the duct installation with the same diameter.

The installation site and mounting should be such that the fan can be mounted securely and without warping. AMD/AMW can be installed and operated in any position. In case of equipment with condensate drain holes, please be aware of their position.

The fans must not be operated in contact with water and effective weather protection must be provided in case of outdoor installation.

In case of operation under more difficult conditions, such as high humidity, excessive strain due to climatic, technical, electronic influences, consultation and approval are required because the standard version is not suitable for this.

Positioning

The use of vibration dampers is recommended (accessories SDD, SDZ) to prevent vibration transmission. Larger motors may protrude from the back and cause uneven distribution due to their high weight. An extension duct VR (accessories) should be provided to adjust the centre of gravity!

Installation examples

Horizontal

– **Figure 2**
Free intake, outlet-side operation with silencer provided with intermediate flanges. Duct silencers can be provided with intermediate flanges to reduce the inlet-side or outlet-side sound power.

– **Figure 3**
Ceiling suspension

Figure 3 shows a typical installation in a ventilation application. The installation of AMD/AMW systems is possible through direct ceiling suspension via mounting bracket (MK) and vibration damper (accessories SDD, SDZ). The tubular casing with double-sided flanges (according to DIN 24155 p. 3) is designed for direct installation in the pipeline.

Figure 1

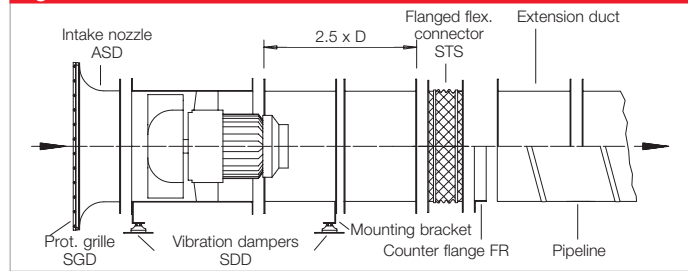

Figure 2

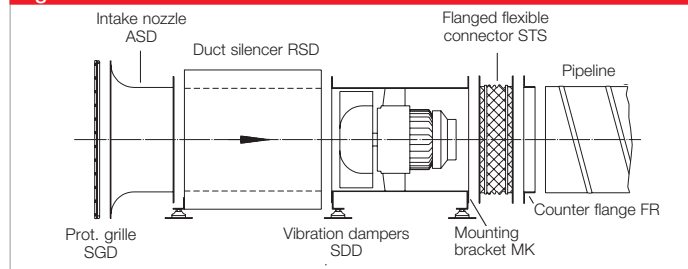
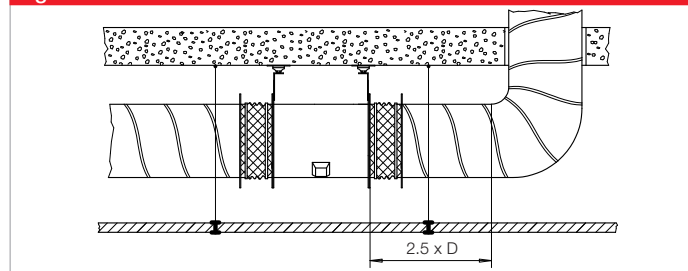

Figure 3



Vertical

– **Figure 4**

Integrated in the pipeline with inlet-side silencer. Wall mounted with brackets or through the ceiling. The elements must be suspended separately according to weight. Do not mount the fan with combined loads for inspection. Mounting rings MRV are available for the vertical attachment of the fan for size 315 and above. The fan weight including the attached accessories must not exceed the load-bearing capacity of the MRV.

Figure 4

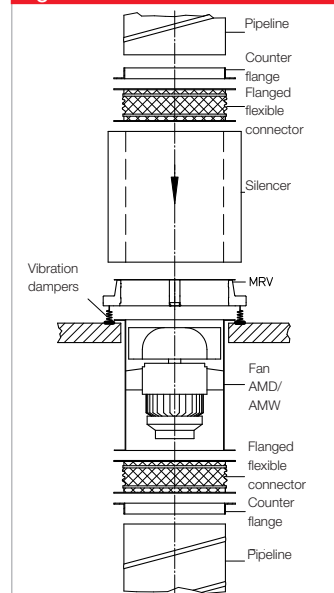

Reference	Page
Planning information, Acoustics	14 ff.
General techn. information, power control	19 ff.

By combining the parameters of static pressure increase Δp_{fa} , flow rate V , speed min^{-1} , sound pressure level dB(A) and impeller diameter DN mm, the following table facilitates the selection of AMD/AMW medium pressure fans.

Diameter mm	Speed min^{-1}	Sound press. inlet side L_{PA} dB(A) at 4 m dist.	Flow rate V m^3/h depending on static pressure = N / m^2 = freely available pressure (ΔP_{fa}) in Pa												
			0	25	50	75	100	150	200	300	400	500	600	700	800
225	2800	53	1950	1900	1860	1780	1720	1590	1400						
225	1400	38	950	840	710										
250	2800	56	2620	2550	2480	2410	2340	2180	1980						
250	1400	42	1360	1250	1080										
280	2800	59	3970	3910	3850	3760	3690	3540	3360	3020					
280	1400	44	1930	1810	1650	1450									
315	2800	63	5440	5360	5300	5240	5160	4970	4810	4450	4020				
315	1400	48	2870	2730	2590	2390	2210								
355	2800	68	8610	8540	8470	8390	8310	8140	7970	7600	7180	6760	6260	5490	
355	1400	52	4170	4040	3860	3660	3470	3070							
400	2800	73	12420	12330	12250	12160	12060	11870	11700	11310	10870	10420	9890	9260	8450
400	1400	56	6000	5810	5600	5400	5200	4740	3940						

AMD and AMW 225



Dimensions AMD and AMW 225

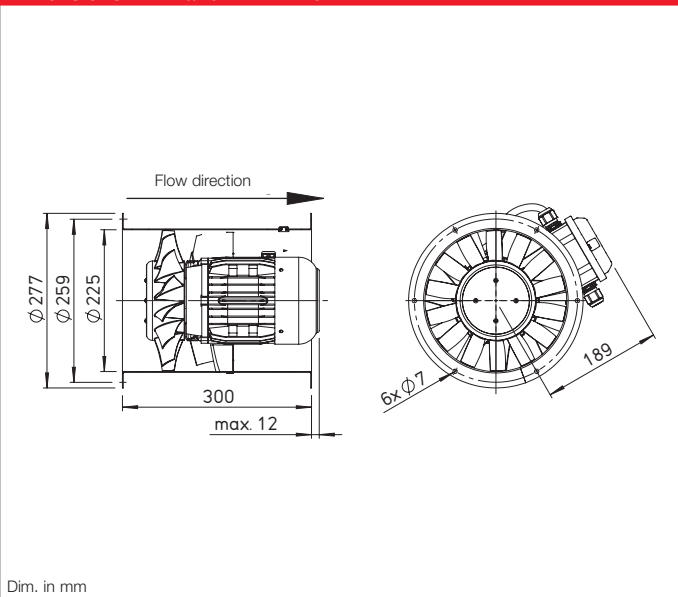

Dim. in mm

Casing

Duct with double-sided flange DIN 24155 p. 3. Made of galvanised steel sheet, fixed guide wheel with inner hub for mounting the flange motor.

Impeller / guide wheel

Impeller with 3D profiled blades and integrated flow geometry made of high-quality plastic. An optimised guide wheel made of galvanised steel is connected to the impeller. The impeller and guide wheel are efficiency-optimised and pressure-optimised for high volume flows by means of CFD. Dynamically balanced in accordance with ISO 21940-11. Operating range -30 to +60 °C.

Drive

Directly through maintenance-free flange motor. Closed design type IP54. Aluminium casing with cooling fins. Radio interference-free, sealed ball bearings. With condensate drain holes upon request and the installation method must be indicated when placing the order. Tropicalised winding with moisture proof coating upon request.

Power control

The voltage-controllable types are identified in the "Current consumption with control mode" column with a value which must be observed when determining the controller (see "speed controller" column). The flow rates are shown in the performance diagram. The planned use of a frequency inverter without a sine filter should be indicated when placing the order. This requires a change of fan version and additional costs, if necessary.

Electrical connection

Standard terminal box (protection category IP55) on outside of duct.

Installation

Installation possible in any position. Condensate drain holes in the motor depending on usage are possible upon request.

Motor protection

All types are equipped with thermal contacts. These should be wired with the motor protection circuit breaker (see type table) for effective motor protection.

Noise levels

See performance diagram. The sound power and sound pressure at 4 m distance under free field conditions are specified for the average operating point on the inlet/outlet side. See page 14 f for noise emissions and room acoustics.

Reference	Page
Selection table	229
Planning information	14 ff.

Special design

Different voltage, frequency, protection category, higher air flow temperature and acid protection upon request.

Other accessories	Page
Installation accessories	276 ff.
Silencers	494 ff.
Switching and control technology	599 ff.

Type	Ref. no.	Speed min ⁻¹	Flow rate free blowing V m ³ /h	Power consump. kW	Voltage V	Current consumption		Wiring diagram No.	Max. air flow temp.		Weight net aprx. kg	Speed controller 5-step		Frequency inverter with integrated sine filter	
						at rated voltage A	with control A		at rated voltage + °C	with control + °C		Type	Ref. no.	Type	Ref. no.
Single-phase alternating current, 50 Hz, protection category IP54															
AMW 225/4	02242	1425	965	0.6	230	0.3	0.3	966.1	60	40	8.7	MWS 1.5 ¹⁾	01947	—	—
AMW 225/2	02243	2750	1955	0.26	230	1.2	1.4	966.1	60	40	9.0	MWS 1.5 ¹⁾	01947	—	—
Three-phase current, 50 Hz, protection category IP54															
AMD 225/4	02244	1430	960	0.06	400	0.2	0.25	469	60	40	8.3	RDS 1 ¹⁾	01314	—	—
AMD 225/2	02245	2760	1950	0.25	400	0.6	0.65	469	60	40	8.8	RDS 1 ¹⁾	01314	—	—

¹⁾ incl. motor protection circuit breaker.

Performance curves AMD and AMW 225/2

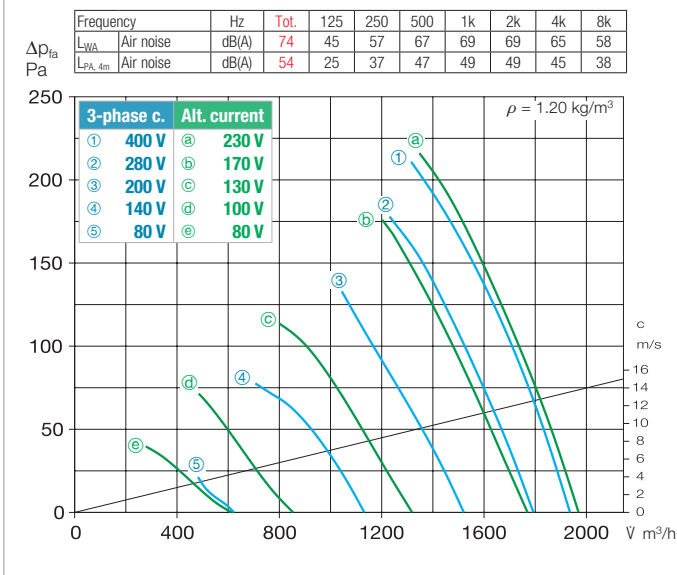

Performance curves AMD and AMW 225/4

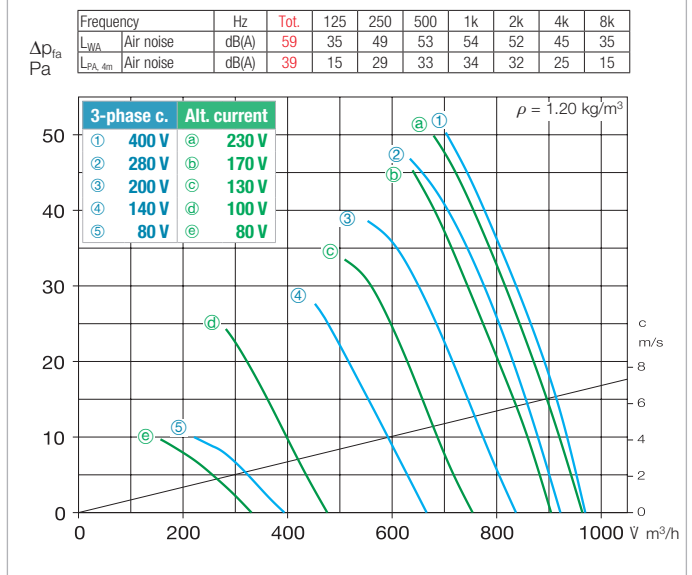

* Three-phase current noise data. Alternating current noise data see www.HeliosSelect.de.

Accessories AMD and AMW 225

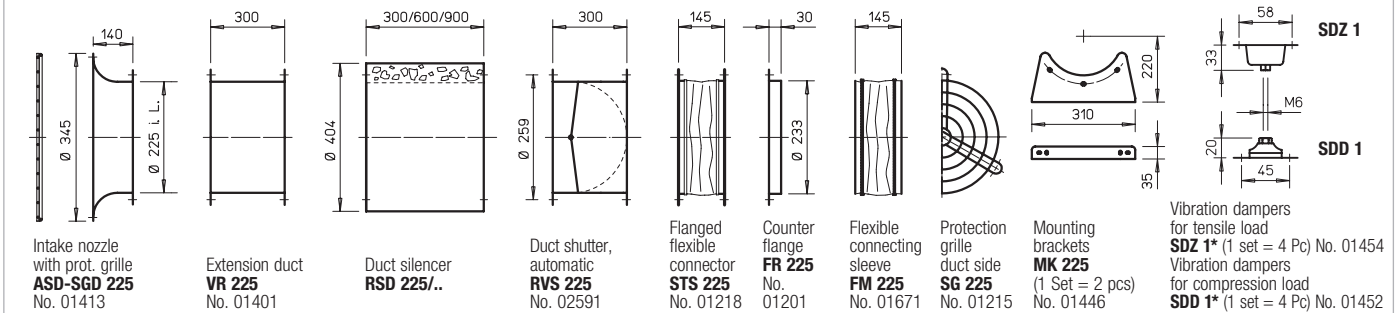

^{a)} Shutter, motorised see Accessories product pages. * Type assignment see table, last column.

		Vibration dampers			
		Compression		Tension	
Type	Ref. no.	Type	Ref. no.	Type	Ref. no.
MW	01579	SDD 1	01452	SDZ 1	01454
MW	01579	SDD 1	01452	SDZ 1	01454
MD	05849	SDD 1	01452	SDZ 1	01454
MD	05849	SDD 1	01452	SDZ 1	01454

AMD and AMW 250



Dimensions AMD and AMW 250

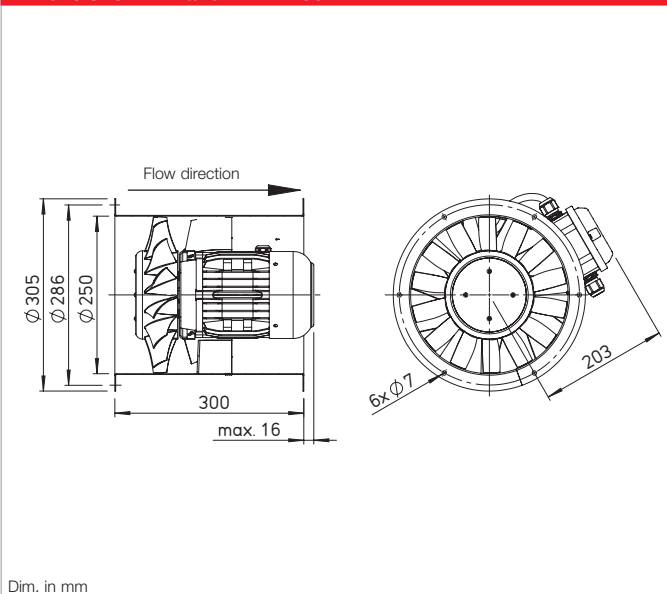

Dim. in mm

- Casing**
Duct with double-sided flange DIN 24155 p. 3. Made of galvanized steel sheet, fixed guide wheel with inner hub for mounting the flange motor.
- Impeller / guide wheel**
Impeller with 3D profiled blades and integrated flow geometry made of high-quality plastic. An optimised guide wheel made of galvanized steel is connected to the impeller. The impeller and guide wheel are efficiency-optimised and pressure-optimised for high volume flows by means of CFD. Dynamically balanced in accordance with ISO 21940-11. Operating range -30 to +60 °C.
- Drive**
Directly through maintenance-free flange motor. Closed design type IP54. Aluminium casing with cooling fins. Radio interference-free, sealed ball bearings. With condensate drain holes upon request and the installation method must be indicated when placing the order. Tropicalised winding with moisture proof coating upon request.

- Power control**
The voltage-controllable types are identified in the "Current consumption with control mode" column with a value which must be observed when determining the controller (see "speed controller" column). The flow rates are shown in the performance diagram. The planned use of a frequency inverter without a sine filter should be indicated when placing the order. This requires a change of fan version and additional costs, if necessary.
- Electrical connection**
Standard terminal box (protection category IP55) on outside of duct.

- Installation**
Installation possible in any position. Condensate drain holes in the motor depending on usage are possible upon request.

- Motor protection**
All types are equipped with thermal contacts. These should be wired with the motor protection circuit breaker (see type table) for effective motor protection.
- Noise levels**
See performance diagram. The sound power and sound pressure at 4 m distance under free field conditions are specified for the average operating point on the inlet/outlet side. See page 14 f for noise emissions and room acoustics.

Reference	Page
Selection table	229
Planning information	14 ff.

Special design

Different voltage, frequency, protection category, higher air flow temperature and acid protection upon request.

Other accessories	Page
Installation accessories	276 ff.
Silencers	494 ff.
Switching and control technology	599 ff.

Type	Ref. no.	Speed min ⁻¹	Flow rate free blowing V m ³ /h	Power consump. kW	Voltage V	Current consumption		Wiring diagram No.	Max. air flow temp.		Weight net aprx. kg	Speed controller 5-step		Frequency inverter with integrated sine filter	
						at rated voltage A	with control A		at rated voltage + °C	with control + °C		Type	Ref. no.	Type	Ref. no.
Single-phase alternating current, 50 Hz, protection category IP54															
AMW 250/4	02248	1435	1360	0.1	230	0.6	0.6	966.1	60	40	9.0	MWS 1.5 ¹⁾	01947	—	—
AMW 250/2	02249	2630	2620	0.4	230	1.9	1.9	966.1	60	40	9.5	MWS 3 ¹⁾	01948	—	—
Three-phase current, 50 Hz, protection category IP54															
AMD 250/4	02250	1430	1380	0.08	400	0.3	0.3	469	60	40	9.2	RDS 1 ¹⁾	01314	—	—
AMD 250/2	02251	2830	2790	0.43	400	1	1	469	60	40	11.0	RDS 2 ¹⁾	01315	FU-BS 2.5	05459

¹⁾ incl. motor protection circuit breaker.

Performance curves AMD and AMW 250/2

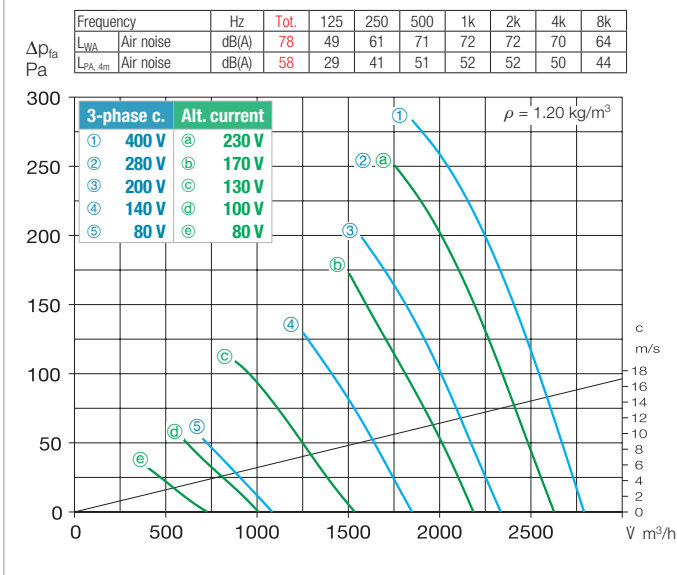

Performance curves AMD and AMW 250/4

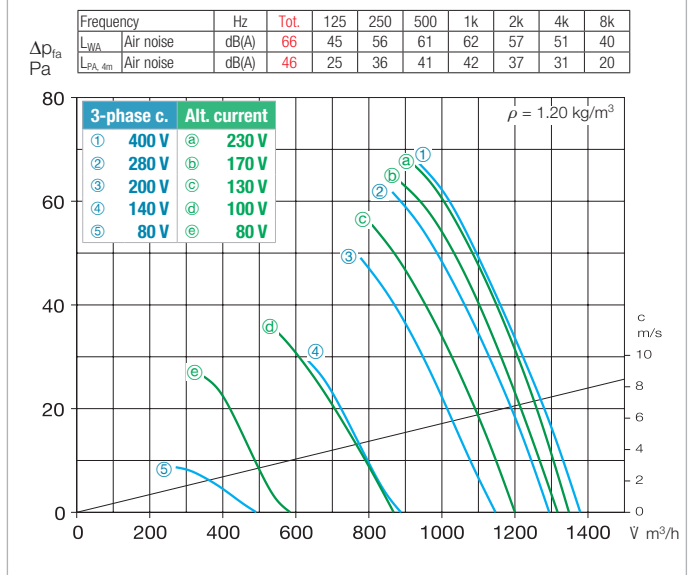

* Three-phase current noise data. Alternating current noise data see www.HeliosSelect.de.

Accessories AMD and AMW 250

Intake nozzle with prot. grille
ASD-SGD 250
No. 01414

Extension duct
VR 250
No. 01402

Duct silencer
RSD 250/..

Duct shutter, automatic
RVS 250^{a)}
No. 02592

Flanged flexible connector
STS 250
No. 01220

Counter flange
FR 250
No. 01203

Flat flange
FF 250
No. 04941

Flexible connecting sleeve
FM 250
No. 01672

Protection grille duct side
SG 250
No. 01236

Mounting brackets
MK 250
(1 Set = 2 pcs)
No. 01447

Vibration dampers for tensile load
SDZ 1* (1 set = 4 Pc) No. 01454

Vibration dampers for compression load
SDD 1* (1 set = 4 Pc) No. 01452

^{a)} Shutter, motorised see Accessories product pages. * Type assignment see table, last column.

		Vibration dampers			
		Compression		Tension	
Type	Ref. no.	Type	Ref. no.	Type	Ref. no.
MW	01579	SDD 1	01452	SDZ 1	01454
MW	01579	SDD 1	01452	SDZ 1	01454
MD	05849	SDD 1	01452	SDZ 1	01454
MD	05849	SDD 1	01452	SDZ 1	01454

AMD and AMW 280



Dimensions AMD and AMW 280

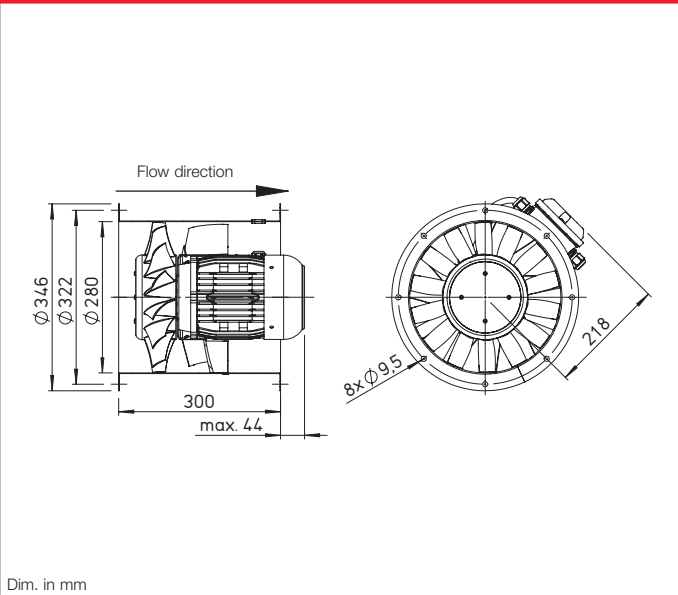

Dim. in mm

- Casing**
Duct with double-sided flange DIN 24155 p. 3. Made of galvanized steel sheet, fixed guide wheel with inner hub for mounting the flange motor.
- Impeller / guide wheel**
Impeller with 3D profiled blades and integrated flow geometry made of high-quality plastic. An optimised guide wheel made of galvanized steel is connected to the impeller. The impeller and guide wheel are efficiency-optimised and pressure-optimised for high volume flows by means of CFD. Dynamically balanced in accordance with ISO 21940-11. Operating range -30 to +60 °C.
- Drive**
Directly through maintenance-free flange motor. Closed design type IP54. Aluminium casing with cooling fins. Radio interference-free, sealed ball bearings. With condensate drain holes upon request and the installation method must be indicated when placing the order. Tropicalised winding with moisture proof coating upon request.
- Power control**
The voltage-controllable types are identified in the "Current consumption with control mode" column with a value which must be observed when determining the controller (see "speed controller" column). The flow rates are shown in the performance diagram. The planned use of a frequency inverter without a sine filter should be indicated when placing the order. This requires a change of fan version and additional costs, if necessary.
- Electrical connection**
Standard terminal box (protection category IP55) on outside of duct.
- Installation**
Installation possible in any position. Condensate drain holes in the motor depending on usage are possible upon request.

- Motor protection**
All types are equipped with thermal contacts. These should be wired with the motor protection circuit breaker (see type table) for effective motor protection.
 - Noise levels**
See performance diagram. The sound power and sound pressure at 4 m distance under free field conditions are specified for the average operating point on the inlet/outlet side. See page 14 f for noise emissions and room acoustics.
- | ■ Reference | Page |
|----------------------|--------|
| Selection table | 229 |
| Planning information | 14 ff. |
- Special design**
Different voltage, frequency, protection category, higher air flow temperature and acid protection upon request.
- | ■ Other accessories | Page |
|----------------------------------|---------|
| Installation accessories | 276 ff. |
| Silencers | 494 ff. |
| Switching and control technology | 599 ff. |

Type	Ref. no.	Speed min ⁻¹	Flow rate free blowing V m ³ /h	Power consump. kW	Voltage V	Current consumption		Wiring diagram No.	Max. air flow temp.		Weight net aprx. kg	Speed controller 5-step		Frequency inverter with integrated sine filter	
						at rated voltage A	with control A		at rated voltage + °C	with control + °C		Type	Ref. no.	Type	Ref. no.
Single-phase alternating current, 50 Hz, protection category IP54															
AMW 280/4	02254	1345	1930	0.1	230	0.5	0.5	966.1	60	40	11.5	MWS 1.5 ¹⁾	01947	—	—
AMW 280/2	02255	2755	3970	0.7	230	3.2	4.3	976.1	60	40	15.5	MWS 5 ¹⁾	01949	—	—
Three-phase current, 50 Hz, protection category IP54															
AMD 280/4	02256	1385	2000	0.1	400	0.3	0.3	469	60	40	10.5	RDS 1 ¹⁾	01314	—	—
AMD 280/2	02257	2745	3960	0.7	400	1.4	1.5	469	60	40	13.8	RDS 2 ¹⁾	01315	FU-BS 2.5	05459

¹⁾ incl. motor protection circuit breaker.

Performance curves AMD and AMW 280/2

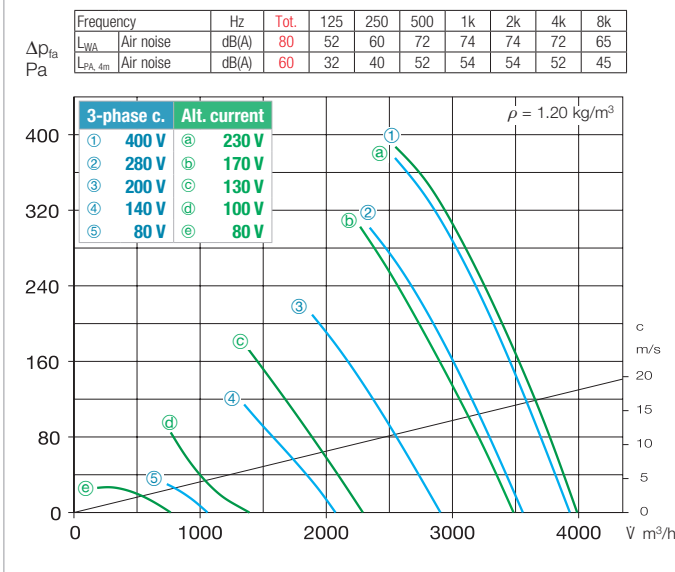

Performance curves AMD and AMW 280/4

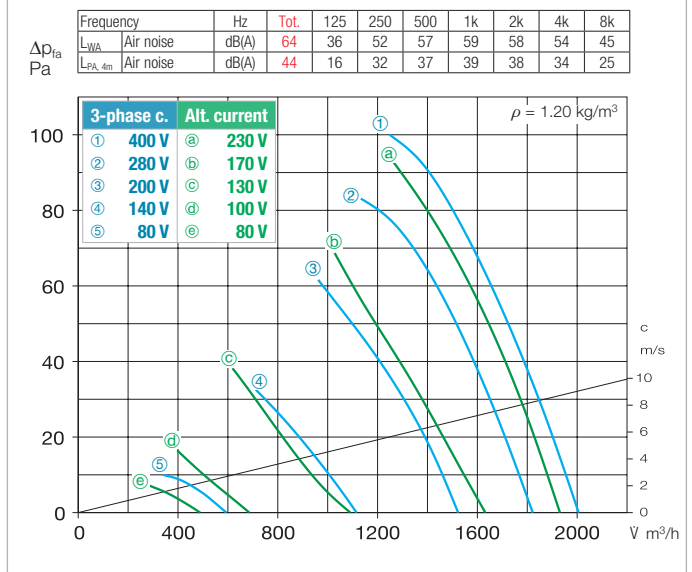

* Three-phase current noise data. Alternating current noise data see www.HeliosSelect.de.

Accessories AMD and AMW 280

Intake nozzle with prot. grille ASD-SGD 280 No. 01415	Extension duct VR 280 No. 01403	Duct silencer RSD 280/..	Duct shutter, automatic RVS 280^{a)} No. 02593	Flanged flexible connector STS 280 No. 01231	Counter flange FR 280 No. 01214	Flat flange FF 280 No. 04942	Flexible connecting sleeve FM 280 No. 01673	Protection grille duct side SG 280 No. 01428	Mounting brackets MK 280 (1 Set = 2 pcs) No. 01447	Vibration dampers for tensile load SDZ 1* (1 set = 4 Pc) No. 01454 Vibration dampers for compression load SDD 1* (1 set = 4 Pc) No. 01452
--	--	------------------------------------	---	---	--	---	--	---	--	--

^{a)} Shutter, motorised see Accessories product pages. * Type assignment see table, last column.

		Vibration dampers			
		Compression		Tension	
Type	Ref. no.	Type	Ref. no.	Type	Ref. no.
MW	01579	SDD 1	01452	SDZ 1	01454
MW	01579	SDD 1	01452	SDZ 1	01454
MD	05849	SDD 1	01452	SDZ 1	01454
MD	05849	SDD 1	01452	SDZ 1	01454

AMD and AMW 315



Dimensions AMD and AMW 315

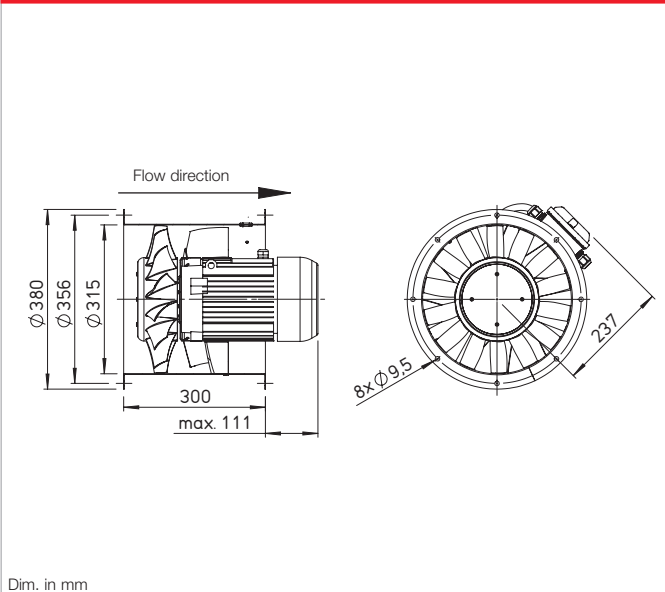

Dim. in mm

■ **Casing**

Duct with double-sided flange DIN 24155 p. 3. Made of galvanised steel sheet, fixed guide wheel with inner hub for mounting the flange motor.

■ **Impeller / guide wheel**

Impeller with 3D profiled blades and integrated flow geometry made of high-quality plastic. An optimised guide wheel made of galvanised steel is connected to the impeller. The impeller and guide wheel are efficiency-optimised and pressure-optimised for high volume flows by means of CFD. Dynamically balanced in accordance with ISO 21940-11. Operating range -30 to +60 °C.

■ **Drive**

Directly through maintenance-free flange motor. Closed design type IP54. Aluminium casing with cooling fins. Radio interference-free, sealed ball bearings. With condensate drain holes upon request and the installation method must be indicated when placing the order. Tropicalised winding with moisture proof coating upon request.

■ **Power control**

The voltage-controllable types are identified in the "Current consumption with control mode" column with a value which must be observed when determining the controller (see "speed controller" column). The flow rates are shown in the performance diagram. The planned use of a frequency inverter without a sine filter should be indicated when placing the order. This requires a change of fan version and additional costs, if necessary.

■ **Electrical connection**

Standard terminal box (protection category IP55) on outside of duct.

■ **Installation**

Installation possible in any position. Condensate drain holes in the motor depending on usage are possible upon request.

■ **Motor protection**

All types are equipped with thermal contacts. These should be wired with the motor protection circuit breaker (see type table) for effective motor protection.

■ **Noise levels**

See performance diagram. The sound power and sound pressure at 4 m distance under free field conditions are specified for the average operating point on the inlet/outlet side. See page 14 f for noise emissions and room acoustics.

Reference	Page
Selection table	229
Planning information	14 ff.
Special design	
Different voltage, frequency, protection category, higher air flow temperature and acid protection upon request.	

Other accessories	Page
Installation accessories	276 ff.
Silencers	494 ff.
Switching and control technology	599 ff.

Type	Ref. no.	Speed min ⁻¹	Flow rate free blowing V m ³ /h	Power consump. kW	Voltage V	Current consumption		Wiring diagram No.	Max. air flow temp.		Weight net aprx. kg	Speed controller 5-step		Frequency inverter with integrated sine filter		
						at rated voltage A	with control A		at rated voltage + °C	with control + °C		Type	Ref. no.	Type	Ref. no.	
Single-phase alternating current, 50 Hz, protection category IP54																
AMW 315/4	02265	1395	2860	0.2	230	1	1.1	966.1	60	40	13.1	MWS 1.5 ¹⁾	01947	—	—	
Three-phase current, 50 Hz, protection category IP54																
AMD 315/4	02266	1455	2950	0.2	400	0.6	0.6	469	60	40	12.2	RDS 1 ¹⁾	01314	—	—	
Two-speed, three-phase current, 50 Hz, Y/Δ connection, protection category IP54																
AMD 315/2/2	02267	2200/2650	4450/5450	0.7/1.1	400/400	1.6/2.5	2.3	520	60	40	18.5	RDS 4 ¹⁾	01316	FU-BS 5.0	05460	

¹⁾ incl. motor protection circuit breaker.

Performance curves AMD 315/2

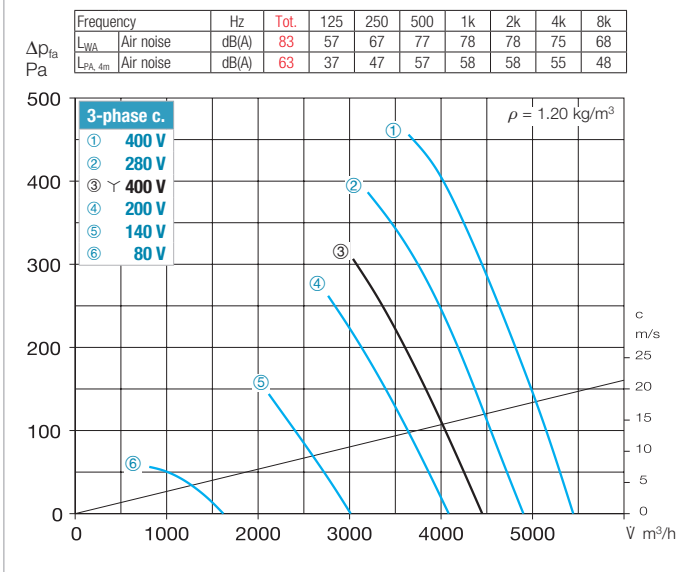

Performance curves AMD and AMW 315/4

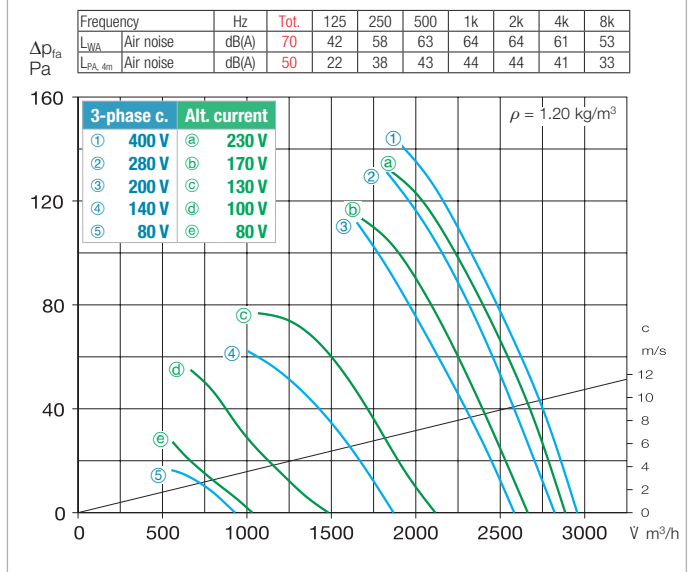

* Three-phase current noise data. Alternating current noise data see www.HeliosSelect.de.

Accessories AMD and AMW 315

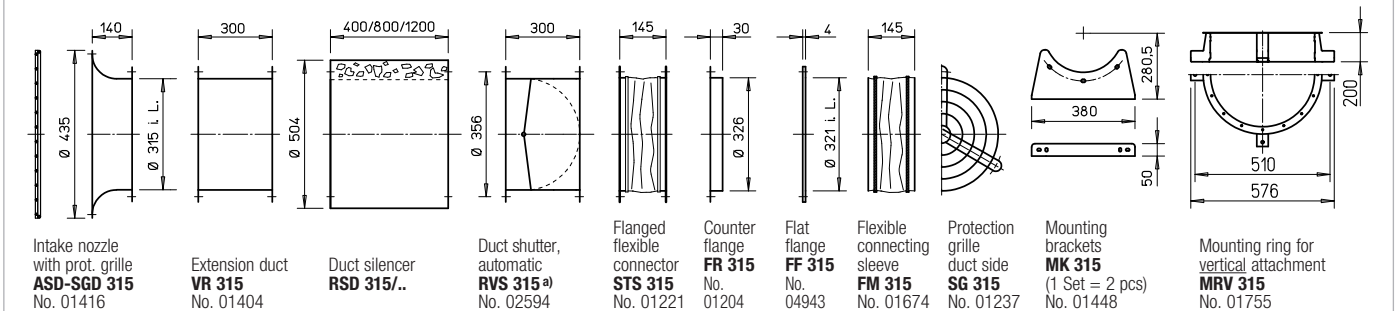

a) Shutter, motorised see Accessories product pages. * Type assignment see table, last column.

		Vibration dampers			
		Compression		Tension	
Motor protection circuit breaker for connecting built-in thermal contacts	Ref. no.	Type	Ref. no.	Type	Ref. no.
MW	01579	SDD 1	01452	SDZ 1	01454
MD	05849	SDD 1	01452	SDZ 1	01454
M 4	01571	SDD 1	01452	SDZ 1	01454

AMD and AMW 355



Dimensions AMD and AMW 355

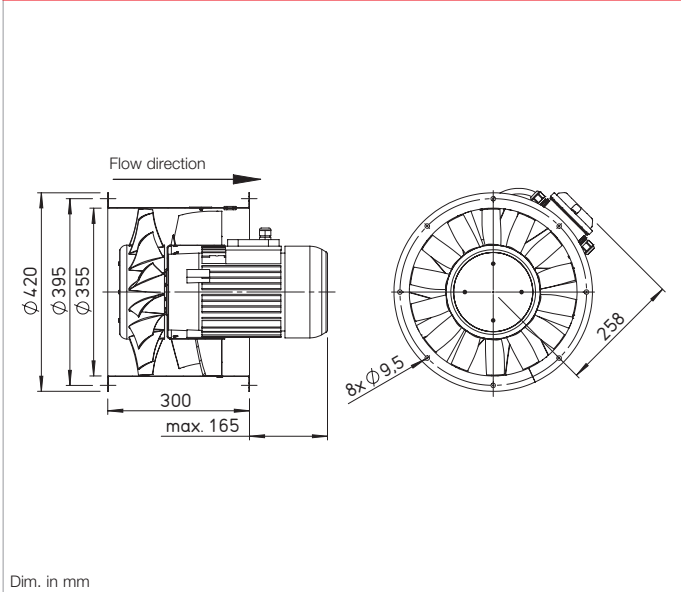

Dim. in mm

■ Casing

Duct with double-sided flange DIN 24155 p. 3. Made of galvanized steel sheet, fixed guide wheel with inner hub for mounting the flange motor.

■ Impeller / guide wheel

Impeller with 3D profiled blades and integrated flow geometry made of high-quality plastic. An optimised guide wheel made of galvanised steel is connected to the impeller. The impeller and guide wheel are efficiency-optimised and pressure-optimised for high volume flows by means of CFD. Dynamically balanced in accordance with ISO 21940-11. Operating range -30 to +60 °C.

■ Drive

Directly through maintenance-free flange motor. Closed design type IP54. Aluminium casing with cooling fins. Radio interference-free, sealed ball bearings. With condensate drain holes upon request and the installation method must be indicated when placing the order. Tropicalised winding with moisture proof coating upon request.

■ Power control

The voltage-controllable types are identified in the "Current consumption with control mode" column with a value which must be observed when determining the controller (see "speed controller" column). The flow rates are shown in the performance diagram. The planned use of a frequency inverter without a sine filter should be indicated when placing the order. This requires a change of fan version and additional costs, if necessary.

■ Electrical connection

Standard terminal box (protection category IP55) on outside of duct.

■ Installation

Installation possible in any position. Condensate drain holes in the motor depending on usage are possible upon request.

■ Motor protection

All types are equipped with thermal contacts. These should be wired with the motor protection circuit breaker (see type table) for effective motor protection.

■ Noise levels

See performance diagram. The sound power and sound pressure at 4 m distance under free field conditions are specified for the average operating point on the inlet/outlet side. See page 14 f for noise emissions and room acoustics.

Reference	Page
Selection table	229
Planning information	14 ff.
Special design	
Different voltage, frequency, protection category, higher air flow temperature and acid protection upon request.	

Other accessories	Page
Installation accessories	276 ff.
Silencers	494 ff.
Switching and control technology	599 ff.

Type	Ref. no.	Speed min ⁻¹	Flow rate free blowing V m ³ /h	Power consump. kW	Voltage V	Current consumption		Wiring diagram No.	Max. air flow temp.		Weight net aprx. kg	Speed controller 5-step		Frequency inverter with integrated sine filter	
						at rated voltage A	with control A		at rated voltage + °C	with control + °C		Type	Ref. no.	Type	Ref. no.
Single-phase alternating current, 50 Hz, protection category IP54															
AMW 355/4	02275	1430	4170	0.4	230	1.8	2.4	968.1	60	40	16.9	MWS 3 ¹⁾	01948	—	—
Three-phase current, 50 Hz, protection category IP54															
AMD 355/4	02276	1445	4300	0.35	400	0.9	1.1	469	60	40	15.7	RDS 2 ¹⁾	01315	FU-BS 2.5	05459
Two-speed, three-phase current, 50 Hz, Y/Δ connection, protection category IP54															
AMD 355/2/2	02277	2200/2775	8610/7640	1.3/2.3	400/400	3.0/5.4	5.6	520	60	40	30.3	RDS 7 ¹⁾	01578	FU-BS 8.0	05461

¹⁾ incl. motor protection circuit breaker.

Performance curves AMD 355/2

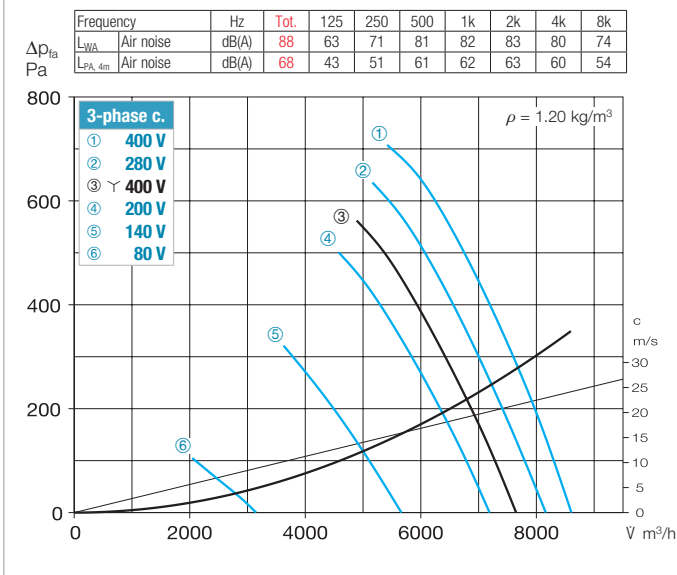

Performance curves AMD and AMW 355/4

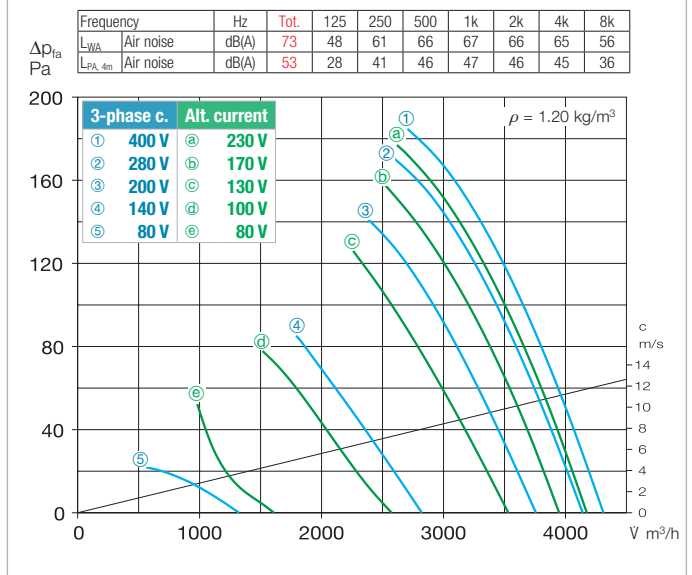

* Three-phase current noise data. Alternating current noise data see www.HeliosSelect.de.

Accessories AMD and AMW 355

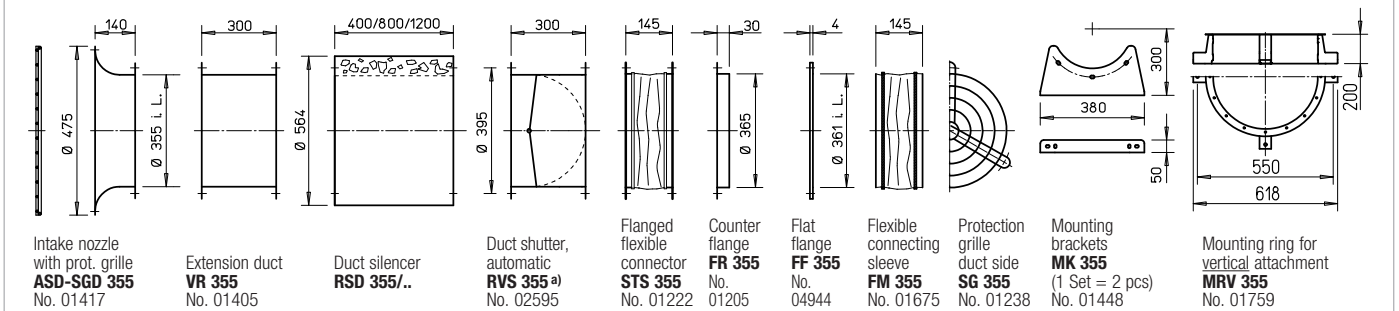

a) Shutter, motorised see Accessories product pages. * Type assignment see table, last column.

		Vibration dampers			
		Compression		Tension	
Type	Ref. no.	Type	Ref. no.	Type	Ref. no.
MW	01579	SDD 1	01452	SDZ 1	01454
MD	05849	SDD 1	01452	SDZ 1	01454
M 4	01571	SDD 1	01452	SDZ 1	01454

AMD and AMW 400



Dimensions AMD and AMW 400

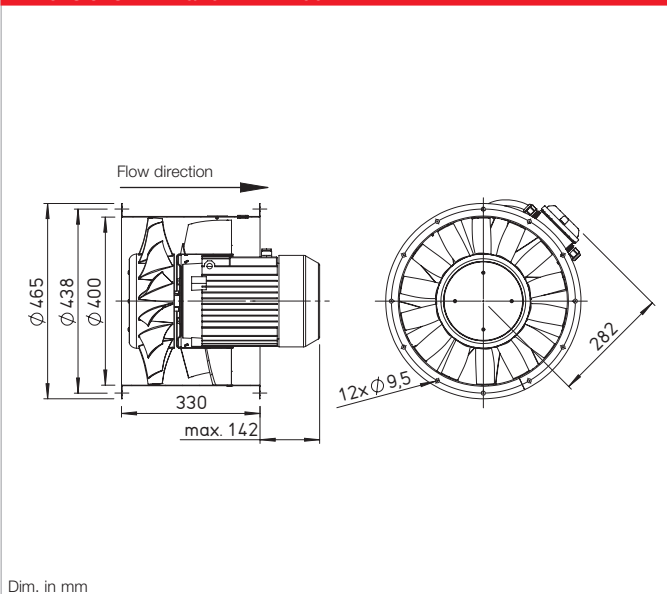

Dim. in mm

Casing

Duct with double-sided flange DIN 24155 p. 3. Made of galvanised steel sheet, fixed guide wheel with inner hub for mounting the flange motor.

Impeller / guide wheel

Impeller with 3D profiled blades and integrated flow geometry made of high-quality plastic. An optimised guide wheel made of galvanised steel is connected to the impeller. The impeller and guide wheel are efficiency-optimised and pressure-optimised for high volume flows by means of CFD. Dynamically balanced in accordance with ISO 21940-11. Operating range -30 to +60 °C.

Drive

Directly through maintenance-free flange motor. Closed design type IP54. Aluminium casing with cooling fins. Radio interference-free, sealed ball bearings. With condensate drain holes upon request and the installation method must be indicated when placing the order. Tropicalised winding with moisture proof coating upon request.

Power control

The voltage-controllable types are identified in the "Current consumption with control mode" column with a value which must be observed when determining the controller (see "speed controller" column). The flow rates are shown in the performance diagram. The planned use of a frequency inverter without a sine filter should be indicated when placing the order. This requires a change of fan version and additional costs, if necessary.

Electrical connection

Standard terminal box (protection category IP55) on outside of duct.

Installation

Installation possible in any position. Condensate drain holes in the motor depending on usage are possible upon request.

Motor protection

All types are equipped with thermal contacts. These should be wired with the motor protection circuit breaker (see type table) for effective motor protection.

Noise levels

See performance diagram. The sound power and sound pressure at 4 m distance under free field conditions are specified for the average operating point on the inlet/outlet side. See page 14 f for noise emissions and room acoustics.

Reference **Page**

Selection table	229
Planning information	14 ff.

Special design

Different voltage, frequency, protection category, higher air flow temperature and acid protection upon request.

Other accessories **Page**

Installation accessories	276 ff.
Silencers	494 ff.
Switching and control technology	599 ff.

Type	Ref. no.	Speed min ⁻¹	Flow rate free blowing V m ³ /h	Power consump. kW	Voltage V	Current consumption		Wiring diagram No.	Max. air flow temp.		Weight net aprx. kg	Speed controller 5-step		Frequency inverter with integrated sine filter	
						at rated voltage A	with control A		at rated voltage + °C	with control + °C		Type	Ref. no.	Type	Ref. no.
Single-phase alternating current, 50 Hz, protection category IP54															
AMW 400/4	02280	1395	6000	0.6	230	2.6	3.1	967.1	60	40	23.2	MWS 5 ¹⁾	01949	—	—
Three-phase current, 50 Hz, protection category IP54															
AMD 400/4	02281	1420	5980	0.6	400	1.9	2	469	60	40	22.0	RDS 4 ¹⁾	01316	FU-BS 2.5	05459
Two-speed, three-phase current, 50 Hz, Y/Δ connection, protection category IP54															
AMD 400/2/2	02282	2280/2780	10880/12430	2.4/4.4	400/400	5.5/9.5	9.5	520	50	30	44.9	RDS 11 ¹⁾	01332	FU-BS 16	05463

¹⁾ incl. motor protection circuit breaker.

Performance curves AMD 400/2

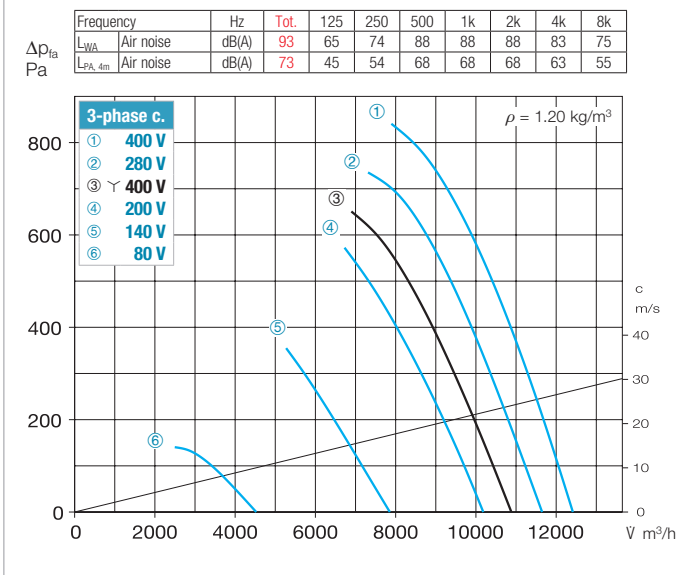

Performance curves AMD and AMW 400/4

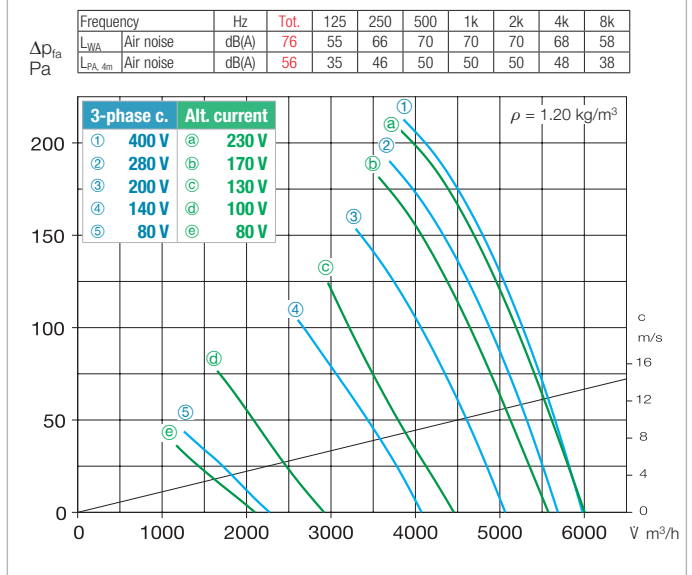

* Three-phase current noise data. Alternating current noise data see www.HeliosSelect.de.

Accessories AMD and AMW 200

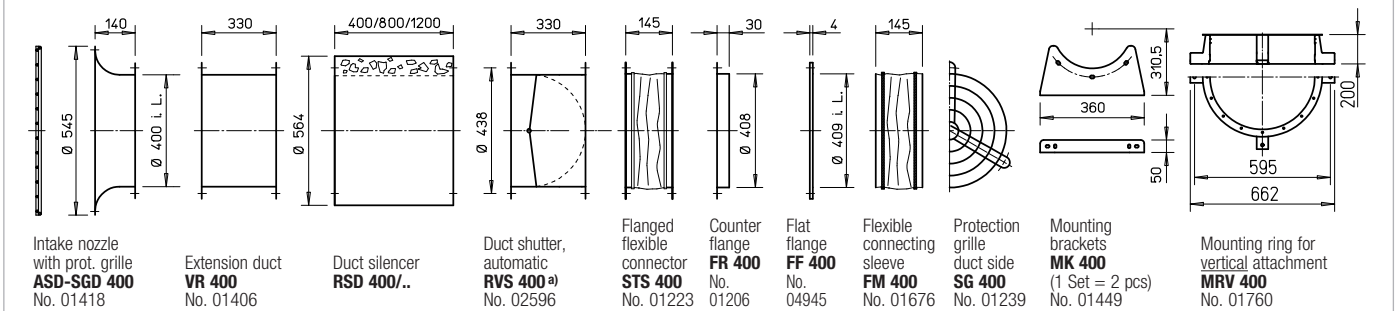

^{a)} Shutter, motorised see Accessories product pages. * Type assignment see table, last column.

		Vibration dampers			
		Compression		Tension	
Motor protection circuit breaker for connecting built-in thermal contacts	Ref. no.	Type	Ref. no.	Type	Ref. no.
MW	01579	SDD 1	01452	SDZ 1	01454
MD	05849	SDD 1	01452	SDZ 1	01454
M 4	01571	SDD 1	01452	SDZ 1	01454

Discover the Helios TGA catalogue.



Simply scan the QR code:

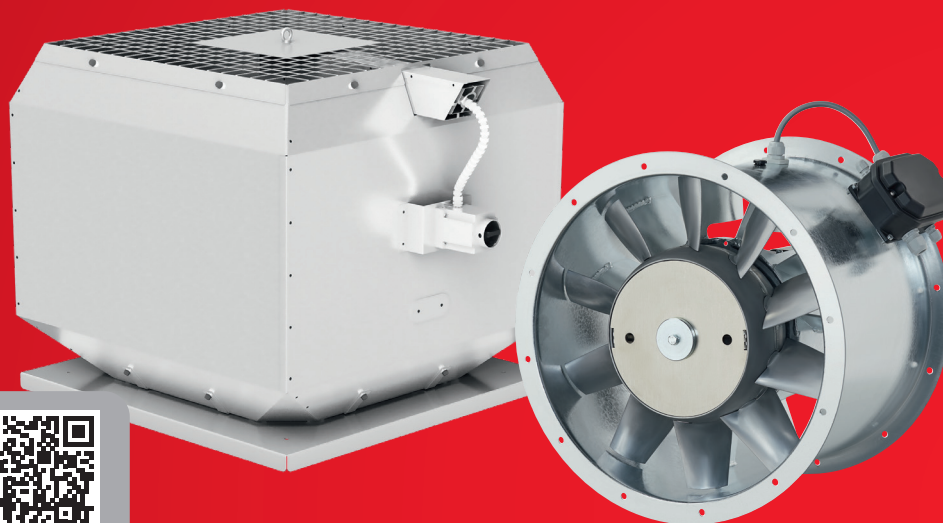

Axial and RADAX® VAR fans

The Helios TGA range includes low pressure and medium pressure axial fans as well as RADAX® VAR high pressure round duct fans in ND 280 to 1250 mm, $V = 1000 - 150\,000$ m³/h for smoke extraction applications with air flow temperatures of 300 °C, 400 °C and 600 °C over 120 min. (F300, F400, F600) or 40 °C for continuous ventilation.

Jet fans

Jet fans are used in parking garages for supply and extract ventilation and they ensure smoke extraction in case of fire.

Low-noise and universally applicable, the Helios axial jet fans set new standards in terms of thrust and weight. The centrifugal models excel on account of their ultra-flat, compact lightweight design and they are ideal when space is limited.

Smoke extraction roof fans and rectangular duct fans

Smoke extraction roof fans are available in ND 315 to 900 mm with flow rates from 1000 to 70 000 m³/h. The versions in temperature class F400 and F600 allow use in mechanical smoke extraction systems.

These fans can also be used for daily ventilation. Smoke extraction rectangular duct fans for rectangular ducts and connectors are ideal for applications with air flow temperatures of 400 °C/120 min.

Smoke protection pressure systems

In case of fire, smoke protection pressure systems (RDA) and stairway scavenging air systems (TSA) ensure life-saving smoke extraction in stairways and fire service lifts. The Helios RDA/TSA concept has a modular structure. The entire system is assembled in just a few steps with pre-configured packages. This guarantees smooth planning, installation and commissioning as well as completely secure system operation.



Request TGA catalogue
Ref. no. 86 979

■ Casing

- Tubular casing with welded-in motor support plate and guide wheel made of steel sheet. Flanges pressed on both sides according to DIN 24155, p. 3, for direct intermediate flanges in pipelines.
- Surface protection from hot-dip galvanising.

■ Impeller

- Hub and blades made of corrosion-resistant aluminium alloy.
- Dynamically balanced according to DIN ISO 21940-11, quality grade 6.3 for low-vibration operation.
- Ten aerodynamically profiled blades achieve the highest levels of efficiency and pressure rates in combination with the guide wheel.
- The angle of attack of the blades can be adjusted in the factory according to the ordered, optimal operating point.

■ Drive

- With regard to single-speed fans with a three-phase current motor and rated motor power ≤ 2.20 kW, the connection for direct start-up is provided (star-delta start-up for fans with rated motor power ≥ 3.00 kW).

□ AMD series

Directly through efficient IE 3 three-phase current standard motor. Pole-changeable fans with IEC standard motor. Protection category IP55, insulation class F.

■ Power control

Continuously variable (0-100 %) through the use of a frequency inverter. The planned use of a frequency inverter without a sine filter should be indicated when placing the order. This requires a change of fan version and additional costs, if necessary.

■ Motor protrusion

- The motor protrudes over the casing for some types. The protrusion dim. B in mm pursuant to the type table must be taken into account.

■ Motor protection

- All AMD types come with PTC thermistors as standard motor protection. Effective motor protection is possible by means of motor protection circuit breaker (type MSA, Ref. no. 01289, accessories) or FU (accessories).

■ Electrical connection

- Standard terminal box (protection category IP55) made of plastic, mounted on the outside of the fan casing.

■ Order data

The desired angle of attack must be specified when ordering.

Example:
AMD 355/2 1.5 kW 34°

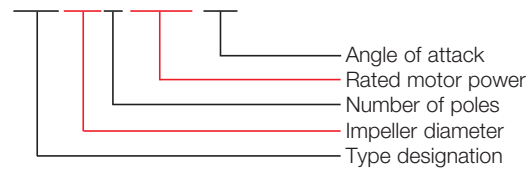

■ Air flow temperatures

- For supply and extract ventilation from -20 °C to $+60$ °C continuous temperature. Types for higher air flow temperatures upon request.

■ Air flow direction

- The fans are designed with air flow direction B = outlet over motor (Figure 1).

■ Noise levels

- The sound power values are specified over the frequency and as total levels for various angles of attack above the performance curves on the product pages.

■ Installation

- Horizontal and vertical installation depending on installation location.
- The use of vibration dampers (accessories) is recommended to prevent vibration transmission.

□ Duct installation (tipping over)

An extension duct (type VR, accessories) must be provided (Figure 2) to prevent the tendency of tipping over when installing medium pressure axial fans with inlet-side and outlet-side flanged flexible connectors (type STS, accessories).

□ Duct installation

Arrangement of mounting brackets (type MK) for horizontal attachment or a mounting ring (type MRV) for vertical attachment to the fan with vibration dampers. Use of vibration dampers for compression (type SDD, accessories) or tensile loads (type SDZ, accessories, for ceiling suspension). Inlet-side and outlet-side flanged flexible connectors (type STS, accessories) must be provided (Figure 3) to prevent the transmission of noise and vibrations.

□ Duct installation with inlet-side and outlet-side silencers

On-site brackets are necessary for attaching the silencers and supporting the weight depending on the local conditions. The inlet-side silencer must be provided with flanged flexible connectors (type STS, accessories) at the inlet (Figure 4) and the outlet-side silencer must be provided with these at the outlet.

Figure 1

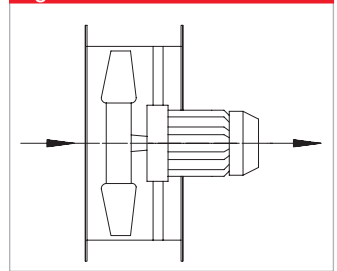

Figure 2

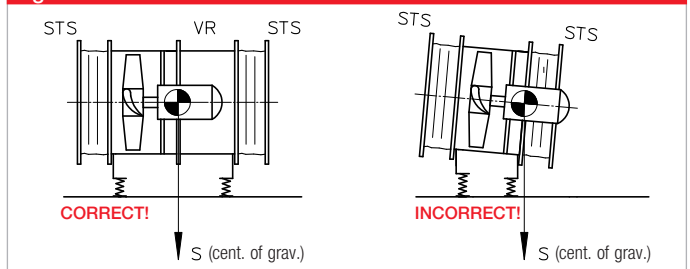

Figure 3

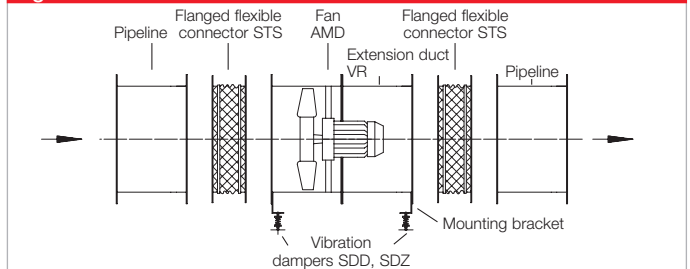

Figure 4

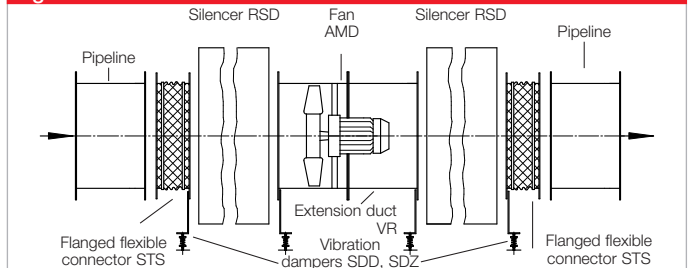
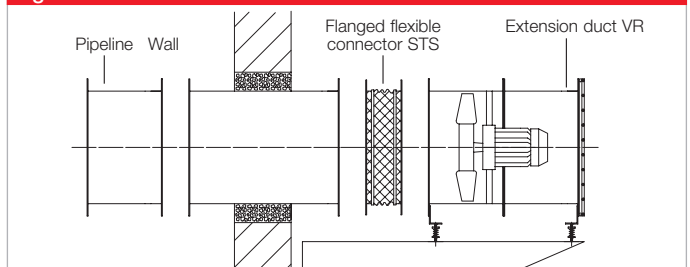

Figure 5



□ Wall installation (horizontal)

On on-site bracket. Wall outlet with round duct or rectangular duct, wall with mineral wool. Inlet-side and outlet-side flanged flexible connector (type STS, accessories) with extension duct (type VR, accessories) and protection grille (type SG, accessories) (Figure 5).

■ Reference

Reference	Page
Planning information	14 ff.
Installation accessories	276 ff.
Silencers	494
Speed controllers, pole changing switches	599 ff.

AMD 450



Dimensions AMD 450

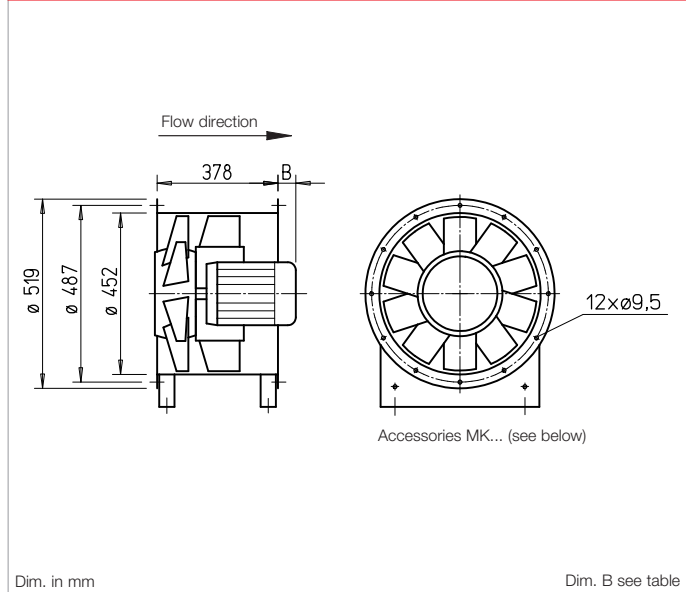

■ Casing

Tubular casing with welded-in motor support plate and guide wheel made of steel sheet. Flanges pressed on both sides according to DIN 24155, p. 3, for direct intermediate flanges in pipelines. Surface protection from hot-dip galvanising.

■ Impeller

Hub and blades made of corrosion-resistant aluminium alloy. Dynamically balanced according to DIN ISO 21940-11, quality grade 6.3 for low-vibration operation. Ten aerodynamically profiled blades achieve the highest levels of efficiency and pressure rates in combination with the guide wheel. The angle of attack of the blades can be adjusted in the factory according to the ordered, optimal operating point.

■ Drive

Directly through efficient IE 3 three-phase current standard motor. Pole-changeable fans with IEC standard motor. Protection category IP55, insulation class F.

■ Power control

Continuously variable (0-100 %) through the use of a frequency inverter. The planned use of a frequency inverter without a sine filter should be indicated when placing the order. This requires a change of fan version and additional costs, if necessary.

■ Electrical connection

Standard terminal box (protection category IP55) made of plastic, mounted on the outside of the fan casing.

■ Motor protection

All AMD types come with PTC thermistors as standard motor protection. Effective motor protection is possible by means of motor protection circuit breaker (type MSA, Ref. no. 01289, accessories) or FU (accessories).

■ Dimensions

The motor protrudes over the casing for some types. The protrusion dim. B in mm pursuant to the type table must be taken into account.

■ Noise levels

The sound power values are specified over the frequency and as total levels for various angles of attack above the performance curves on the product pages.

Reference	Page
Planning information	14 ff.
Special design	
Special design w/ inspect. opening (extra charge) upon request.	

Other accessories	Page
Installation accessories	276 ff.
Silencers	496 ff.
Switching and control technology	599 ff.

Type	Ref. no.	Speed	Rated motor power (output)	Voltage	Current consump. nominal	Dim. B Motor protrusion	Wiring diagram	Max. air flow temp.	Weight net	Frequency inverter with integrated sine filter	Motor protection circuit breaker or pole changing switch
		min ⁻¹	kW	V	A	mm	No.	+ °C	kg	Type	Ref. no.
Three-phase current, 400 V, 50 Hz, protection category IP55											
AMD 450/4 0.75 kW	03109	1430	0.75	400	1.8	15	796	60	40	FU-BS 2.5	05459
AMD 450/4 1.1 kW	03110	1440	1.1	400	2.5	40	796	60	44	FU-BS 5.0	05460
AMD 450/4 2.2 kW	03106	2890	2.2	400	4.3	65	796	60	47	FU-BS 5.0	05460
AMD 450/2 3 kW	03107	2880	3	400*	5.7	105	776	60	54	FU-BS 8.0	05461
AMD 450/2 4 kW	03108	2910	4	400*	7.4	155	776	60	57	FU-BS 8.0	05461
Pole-changeable, 2 speeds, three-phase current, Dahlander winding $\gamma/\gamma\gamma$, 400 V, 50 Hz, protection category IP55										Surface-mounted pole changing switch	
AMD 450/4/2 0.65/2.5 kW	03121	1380/2855	0.65/2.5	400	1.9/5.0	40	777	60	61	—	PDA 12 ¹⁾
AMD 450/4/2 0.8/3.1 kW	03111	1380/2860	0.8/3.1	400	2.1/6.1	65	777	60	61	—	PDA 12 ¹⁾
AMD 450/4/2 1.1/4.4 kW	03113	1390/2860	1.1/4.4	400	3.0/8.7	155	777	60	67	—	PDA 12 ¹⁾

The angle of attack must be specified when ordering. ¹⁾ Flush-m. version see Switch product page.

* γ/Δ Start-up.

Performance curves AMD 450/2

n=2900 1/min

Frequency	Hz	Tot.	125	250	500	1k	2k	4k	8k	
L _{WA}	10°	dB(A)	100	77	90	95	99	99	94	85
L _{WA}	20°	dB(A)	101	79	91	99	100	100	96	87
L _{WA}	30°	dB(A)	104	81	93	101	103	102	98	89

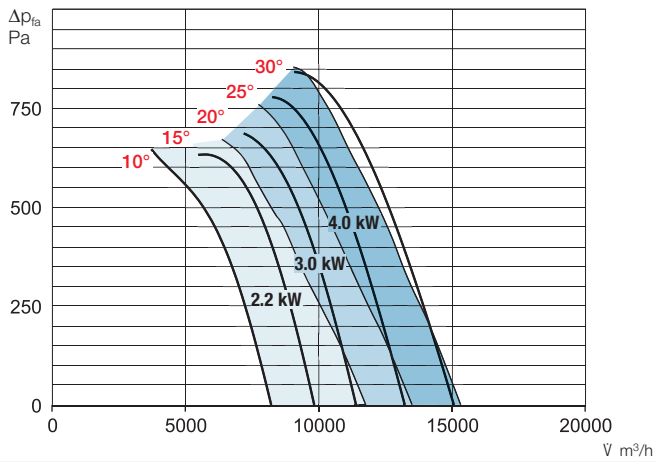

Performance curves AMD 450/4

n=1420 1/min

Frequency	Hz	Tot.	125	250	500	1k	2k	4k	8k	
L _{WA}	10°	dB(A)	83	68	78	81	82	80	73	61
L _{WA}	20°	dB(A)	85	69	79	84	84	82	74	63
L _{WA}	30°	dB(A)	86	71	81	83	85	82	76	65

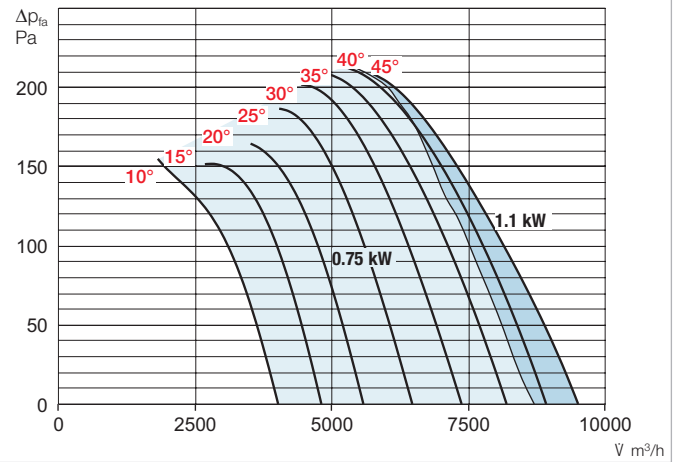

Accessories AMD 450

Intake nozzle with prot. grille **ASD-SGD 450** No. 01419

Extension duct **VR 450** No. 01407

Duct silencer **RSD 450/..**

Duct shutter **RVS 450^{a)}** No. 02597

Flanged flexible connector **STS 450** No. 01224

Counter flange **FR 450** No. 01207

Flat flange **FF 450** No. 04946

Protection grille duct side **SG 450** No. 01240

Mounting brackets **MK 400-450** (1 Set = 2 pcs) No. 01449

Mounting ring for vertical attachment **MRV 450** No. 01761

^{a)} Shutter, motorised, see Accessories product page.

Vibration dampers			
Compression		Tension	
Type	Ref. no.	Type	Ref. no.
SDD 1	01452	SDZ 1	01454
SDD 1	01452	SDZ 1	01454
SDD 1	01452	SDZ 1	01454
SDD 1	01452	SDZ 1	01454
SDD 1	01452	SDZ 1	01454
SDD 1	01452	SDZ 2	01455
SDD 1	01452	SDZ 2	01455
SDD 1	01452	SDZ 2	01455

Axial and VAR fans

AMD 500



Dimensions AMD 500

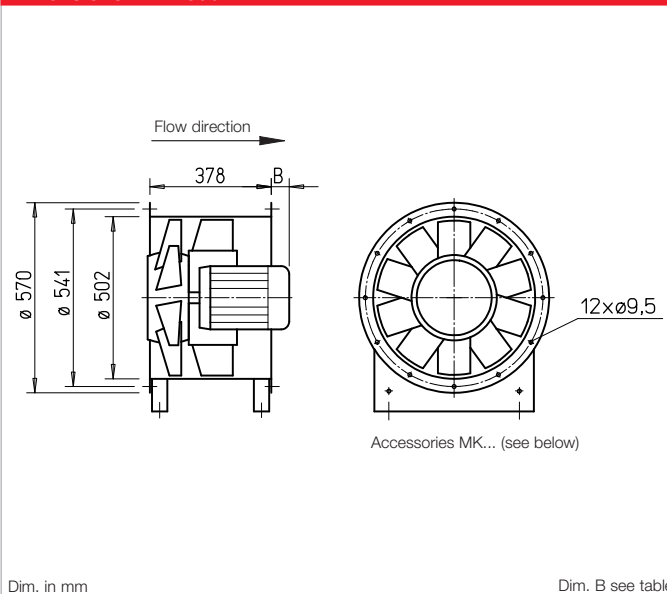

Casing

Tubular casing with welded-in motor support plate and guide wheel made of steel sheet. Flanges pressed on both sides according to DIN 24155, p. 3, for direct intermediate flanges in pipelines. Surface protection from hot-dip galvanising.

Impeller

Hub and blades made of corrosion-resistant aluminium alloy. Dynamically balanced according to DIN ISO 21940-11, quality grade 6.3 for low-vibration operation.

Ten aerodynamically profiled blades achieve the highest levels of efficiency and pressure rates in combination with the guide wheel. The angle of attack of the blades can be adjusted in the factory according to the ordered, optimal operating point.

Drive

Directly through efficient IE 3 three-phase current standard motor. Pole-changeable fans with IEC standard motor. Protection category IP55, insulation class F.

Power control

Continuously variable (0-100 %) through the use of a frequency inverter. The planned use of a frequency inverter without a sine filter should be indicated when placing the order. This requires a change of fan version and additional costs, if necessary.

Electrical connection

Standard terminal box (protection category IP55) made of plastic, mounted on the outside of the fan casing.

Motor protection

All AMD types come with PTC thermistors as standard motor protection. Effective motor protection is possible by means of motor protection circuit breaker (type MSA, Ref. no. 01289, accessories) or FU (accessories).

Dimensions

The motor protrudes over the casing for some types. The protrusion dim. B in mm pursuant to the type table must be taken into account.

Noise levels

The sound power values are specified over the frequency and as total levels for various angles of attack above the performance curves on the product pages.

Reference Page

Planning information 14 ff.

Special design

Special design w/ inspect. opening (extra charge) upon request.

Other accessories Page

Installation accessories 276 ff.

Silencers 494 ff.

Switching and control technology 599 ff.

Type	Ref. no.	Speed	Rated motor power (output)	Voltage	Current consump. nominal	Dim. B Motor protrusion	Wiring diagram	Max. air flow temp.	Weight net	Frequency inverter with integrated sine filter		Motor protection circuit breaker or pole changing switch		
										Type	Ref. no.	Type	Ref. no.	
Three-phase current, 400 V, 50 Hz, protection category IP55														
AMD 500/4 0.75 kW	03118	1430	0.75	400	1.8	35	796	60	46	FU-BS 2.5	05459	MSA	01289	
AMD 500/4 1.1 kW	03119	1440	1.1	400	2.5	60	796	60	50	FU-BS 5.0	05460	MSA	01289	
AMD 500/4 1.5 kW	03122	1440	1.5	400	3.3	85	796	60	53	FU-BS 5.0	05460	MSA	01289	
AMD 500/2 4 kW	03115	2910	4	400*	7.4	175	776	60	83	FU-BS 8.0	05461	MSA	01289	
AMD 500/2 5.5 kW	03116	2940	5.5	400*	10.1	180	776	60	97	FU-BS 16	05463	MSA	01289	
AMD 500/2 7.5 kW	03117	2930	7.5	400*	14.1	220	776	60	102	FU-BS 16	05463	MSA	01289	
Pole-changeable, 2 speeds, three-phase current, Dahlander winding $\gamma/\gamma\gamma$, 400 V, 50 Hz, protection category IP55													Surface-mounted pole changing switch	
AMD 500/8/4 0.22/1.0 kW ³⁾	03275	645/1390	0.22/1.0	400	0.9/2.4	60	777	60	55	—	—	PDA 12 ¹⁾	05081	
AMD 500/8/4 0.3/1.5 kW ³⁾	03276	645/1390	0.3/1.5	400	1.1/3.0	85	777	60	58	—	—	PDA 12 ¹⁾	05081	
AMD 500/8/4 1.4/5.9 kW ³⁾	03273	1400/2900	1.4/5.9	400	3.6/11.4	180	777	60	118	—	—	PDA 12 ¹⁾	05081	
AMD 500/8/4 2.0/8.0 kW ³⁾	03274	1410/2900	2.0/8.0	400	4.7/14.9	220	777	60	129	—	—	PDA 25	05060	

The angle of attack must be specified when ordering.

* γ/Δ Start-up.

¹⁾ Flush-m. version see Switch product page.

²⁾ Extension duct VR over motor protrusion required.

³⁾ Performance curves for low speed available on request.

Performance curves AMD 500/2

n=2930 1/min

Frequency	Hz	Tot.	125	250	500	1k	2k	4k	8k
L _{WA} 10°	dB(A)	103	80	93	99	102	100	97	88
L _{WA} 20°	dB(A)	105	82	94	100	104	102	99	90
L _{WA} 30°	dB(A)	107	84	96	104	106	104	101	92

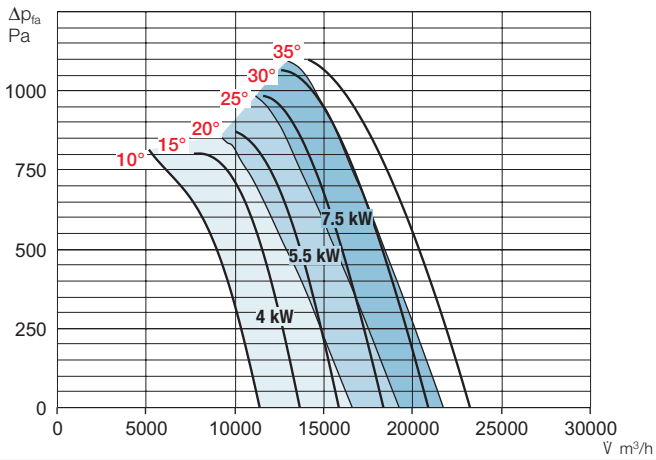

Performance curves AMD 500/4

n=1430 1/min

Frequency	Hz	Tot.	125	250	500	1k	2k	4k	8k
L _{WA} 10°	dB(A)	87	71	81	86	86	83	76	64
L _{WA} 20°	dB(A)	88	72	82	86	87	85	77	66
L _{WA} 30°	dB(A)	90	74	84	88	89	87	79	68

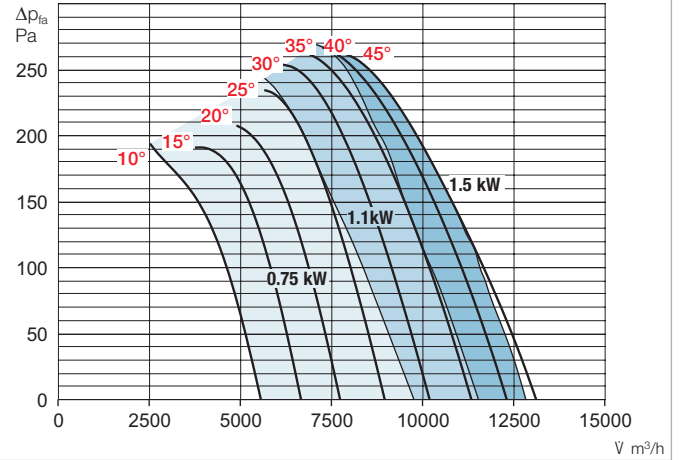

Accessories AMD 500

Intake nozzle with prot. grille ASD-SGD 500 No. 01420	Extension duct VR 500 No. 01408	Duct silencer RSD 500/..	Duct shutter RVS 500 a) No. 02598	Flanged flexible connector STS 500 No. 01225	Counter flange FR 500 No. 01208	Flat flange FF 500 No. 04947	Protection grille duct side SG 500 No. 01241	Mounting brackets MK 500 (1 Set = 2 pcs) No. 00674	Mounting ring for vertical attachment MRV 500 No. 01740

a) Shutter, motorised, see Accessories product page.

Vibration dampers			
Compression		Tension	
Type	Ref. no.	Type	Ref. no.
SDD 1	01452	SDZ 1	01454
SDD 1	01452	SDZ 1	01454
SDD 1	01452	SDZ 1	01454
SDD 2	01453	SDZ 2	01455
SDD 2 ^{a)}	01453	SDZ 2 ^{a)}	01455
SDD 2 ^{a)}	01453	SDZ 2 ^{a)}	01455
SDD 1	01452	SDZ 1	01454
SDD 1	01452	SDZ 2	01455
SDD 2 ^{a)}	01453	SDZ 2 ^{a)}	01455
SDD 2 ^{a)}	01453	SDZ 2 ^{a)}	01455

Axial and VAR fans

AMD 560



Dimensions AMD 560

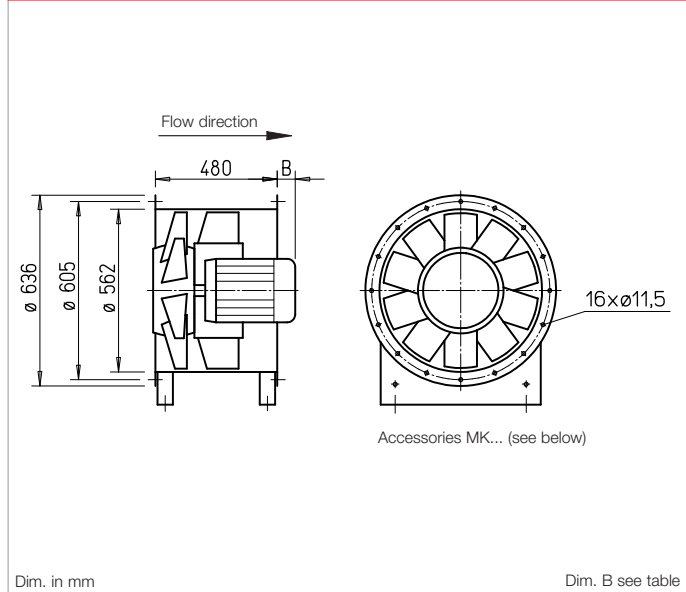

Casing

Tubular casing with welded-in motor support plate and guide wheel made of steel sheet. Flanges pressed on both sides according to DIN 24155, p. 3, for direct intermediate flanges in pipelines. Surface protection from hot-dip galvanising.

Impeller

Hub and blades made of corrosion-resistant aluminium alloy. Dynamically balanced according to DIN ISO 21940-11, quality grade 6.3 for low-vibration operation. Ten aerodynamically profiled blades achieve the highest levels of efficiency and pressure rates in combination with the guide wheel. The angle of attack of the blades can be adjusted in the factory according to the ordered, optimal operating point.

Drive

Directly through efficient IE 3 three-phase current standard motor. Pole-changeable fans with IEC standard motor. Protection category IP55, insulation class F.

Power control

Continuously variable (0-100 %) through the use of a frequency inverter. The planned use of a frequency inverter without a sine filter should be indicated when placing the order. This requires a change of fan version and additional costs, if necessary.

Electrical connection

Standard terminal box (protection category IP55) made of plastic, mounted on the outside of the fan casing.

Motor protection

All AMD types come with PTC thermistors as standard motor protection. Effective motor protection is possible by means of motor protection circuit breaker (type MSA, Ref. no. 01289, accessories) or FU (accessories).

Dimensions

The motor protrudes over the casing for some types. The protrusion dim. B in mm pursuant to the type table must be taken into account.

Noise levels

The sound power values are specified over the frequency and as total levels for various angles of attack above the performance curves on the product pages.

Reference	Page
Planning information	14 ff.
Special design	
Special design w/ inspect. opening (extra charge) upon request.	

Other accessories	Page
Installation accessories	276 ff.
Silencers	494 ff.
Switching and control technology	599 ff.

Type	Ref. no.	Speed	Rated motor power (output)	Voltage	Current consump. nominal	Dim. B Motor protrusion	Wiring diagram	Max. air flow temp.	Weight net	Frequency inverter with integrated sine filter	Motor protection circuit breaker or pole changing switch
		min ⁻¹	kW	V	A	mm	No.	+ °C	kg	Type Ref. no.	Type Ref. no.
Three-phase current, 400 V, 50 Hz, protection category IP55											
AMD 560/4 1.1 kW	03281	1440	1.1	400	2.5	0	796	60	61	FU-BS 5.0 05460	MSA 01289
AMD 560/4 1.5 kW	03282	1440	1.5	400	3.3	0	796	60	64	FU-BS 5.0 05460	MSA 01289
AMD 560/4 2.2 kW	03285	1455	2.2	400	4.5	40	796	60	74	FU-BS 5.0 05460	MSA 01289
AMD 560/4 3 kW	03286	1440	3	400*	6.0	40	776	60	80	FU-BS 8.0 05461	MSA 01289
AMD 560/2 7.5 kW	03279	2930	7.5	400*	14.1	100	776	60	123	FU-BS 16 05463	MSA 01289
Pole-changeable, 2 speeds, three-phase current, Dahlander winding $\gamma/\gamma\gamma$, 400 V, 50 Hz, protection category IP55										Surface-mounted pole changing switch	
AMD 560/8/4 0.55/2.0 kW ²⁾	03272	680/1410	0.55/2.0	400	2.0/4.5	0	777	60	79	— —	PDA 12 ¹⁾ 05081
AMD 560/8/4 0.65/2.4 kW ²⁾	03290	680/1410	0.65/2.4	400	2.5/5.5	40	777	60	79	— —	PDA 12 ¹⁾ 05081
AMD 560/4/2 2.0/8.0 kW	03287	1410/2900	2.0/8.0	400	4.7/14.9	100	777	60	149	— —	PDA 25 05060

The angle of attack must be specified when ordering. ¹⁾ Flush-m. version see Switch product page.

²⁾ Performance curves for low speed available on request.

* γ/Δ Start-up.

Performance curves AMD 560/2

n=2930 1/min

Frequency	Hz	Tot.	125	250	500	1k	2k	4k	8k	
L _{WA}	10°	dB(A)	107	84	96	104	106	105	101	91
L _{WA}	20°	dB(A)	108	85	97	105	107	105	102	93
L _{WA}	30°	dB(A)	111	87	100	107	110	109	105	95

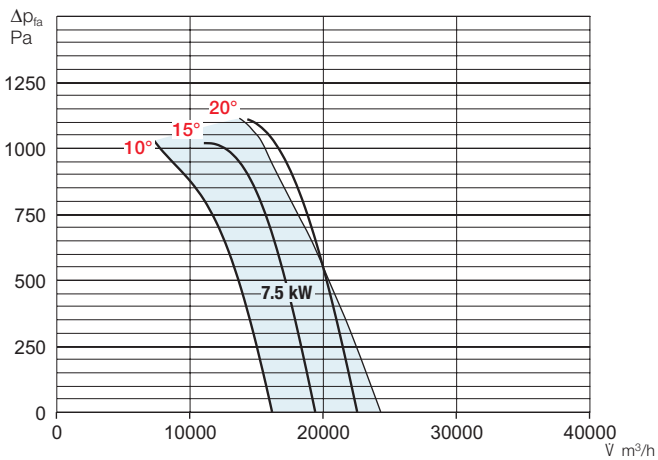

Performance curves AMD 560/4

n=1440 1/min

Frequency	Hz	Tot.	125	250	500	1k	2k	4k	8k	
L _{WA}	10°	dB(A)	90	74	84	89	89	87	79	68
L _{WA}	20°	dB(A)	92	76	85	91	91	88	81	69
L _{WA}	30°	dB(A)	93	77	87	91	92	90	82	71

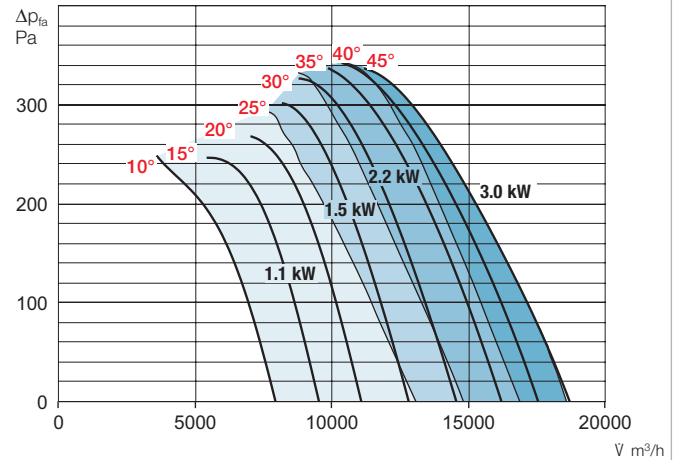

Accessories AMD 560

Intake nozzle with prot. grille **ASD-SGD 560** No. 01421

Extension duct **VR 560** No. 01409

Duct silencer **RSD 560/..**

Duct shutter **RVS 560** ^{a)} No. 02599

Flanged flexible connector **STS 560** No. 01226

Counter flange **FR 560** No. 01209

Flat flange **FF 560** No. 04948

Protection grille duct side **SG 560** No. 01242

Mounting brackets **MK 560** (1 Set = 2 pcs) No. 00675

Mounting ring for vertical attachment **MRV 560** No. 01741

^{a)} Shutter, motorised, see Accessories product page.

Vibration dampers			
Compression		Tension	
Type	Ref. no.	Type	Ref. no.
SDD 1	01452	SDZ 2	01455
SDD 1	01452	SDZ 2	01455
SDD 1	01452	SDZ 2	01455
SDD 2	01453	SDZ 2	01455
SDD 2	01453	SDZ 2	01455
SDD 2	01453	SDZ 2	01455
SDD 2	01453	SDZ 2	01455
SDD 2	01453	SDZ 2	01455
SDD 2	01453	SDZ 2	01455

AMD 630



Dimensions AMD 630

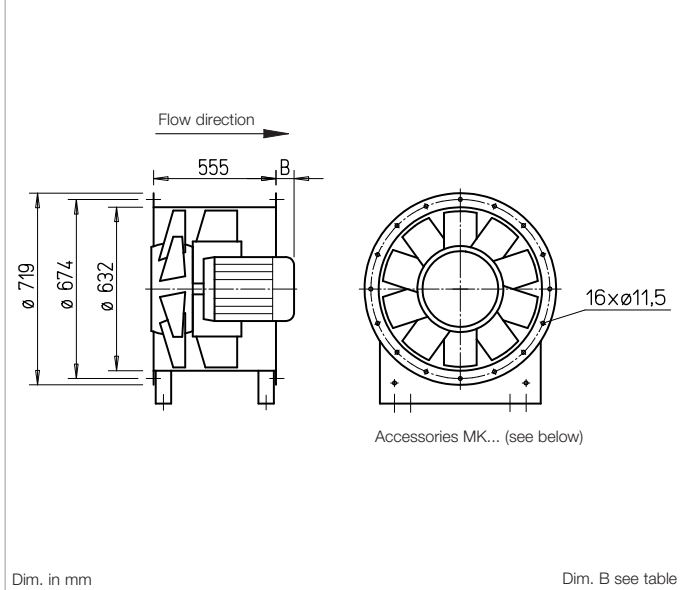

■ Casing

Tubular casing with welded-in motor support plate and guide wheel made of steel sheet. Flanges pressed on both sides according to DIN 24155, p. 3, for direct intermediate flanges in pipelines. Surface protection from hot-dip galvanising.

■ Impeller

Hub and blades made of corrosion-resistant aluminium alloy. Dynamically balanced according to DIN ISO 21940-11, quality grade 6.3 for low-vibration operation. Ten aerodynamically profiled blades achieve the highest levels of efficiency and pressure rates in combination with the guide wheel. The angle of attack of the blades can be adjusted in the factory according to the ordered, optimal operating point.

■ Drive

Directly through efficient IE 3 three-phase current standard motor. Pole-changeable fans with IEC standard motor. Protection category IP55, insulation class F.

■ Power control

Continuously variable (0-100 %) through the use of a frequency inverter. The planned use of a frequency inverter without a sine filter should be indicated when placing the order. This requires a change of fan version and additional costs, if necessary.

■ Electrical connection

Standard terminal box (protection category IP55) made of plastic, mounted on the outside of the fan casing.

■ Motor protection

All AMD types come with PTC thermistors as standard motor protection. Effective motor protection is possible by means of motor protection circuit breaker (type MSA, Ref. no. 01289, accessories) or FU (accessories).

■ Dimensions

The motor protrudes over the casing for some types. The protrusion dim. B in mm pursuant to the type table must be taken into account.

■ Noise levels

The sound power values are specified over the frequency and as total levels for various angles of attack above the performance curves on the product pages.

■ Reference Page

Planning information 14 ff.

Special design

Special design w/ inspect. opening (extra charge) upon request.

■ Other accessories Page

Installation accessories 276 ff.
Silencers 494 ff.
Switching and control technology 599 ff.

Type	Ref. no.	Speed	Rated motor power (output)	Voltage	Current consump. nominal	Dim. B Motor protrusion	Wiring diagram	Max. air flow temp.	Weight net	Frequency inverter with integrated sine filter	Motor protection circuit breaker or pole changing switch
		min ⁻¹	kW	V	A	mm	No.	+ °C	kg	Type Ref. no.	Type Ref. no.
Three-phase current, 400 V, 50 Hz, protection category IP55											
AMD 630/4 1.5 kW	03291	1440	1.5	400	3.3	0	796	60	84	FU-BS 5.0 05460	MSA 01289
AMD 630/4 2.2 kW	03292	1455	2.2	400	4.5	0	796	60	84	FU-BS 5.0 05460	MSA 01289
AMD 630/4 3 kW	03293	1440	3.0	400*	6.0	0	776	60	99	FU-BS 8.0 05461	MSA 01289
AMD 630/4 4 kW	03294	1500	4.0	400*	7.4	30	776	60	94	FU-BS 10.0 05462	MSA 01289
AMD 630/4 5.5 kW	03295	1470	5.0	400*	10.7	40	776	60	115	FU-BS 16 05463	MSA 01289
AMD 630/2 11 kW	03376	2945	11.0	400*	20.0	145	776	60	210	FU-CS 22 05470	MSA 01289
Pole-changeable, 2 speeds, three-phase current, Dahlander winding Δ/Δ, 400 V, 50 Hz, protection category IP55										Surface-mounted pole changing switch	
AMD 630/8/4 0.55/2.0 kW ²⁾	03297	680/1410	0.55/2.0	400	2.0/4.5	0	777	60	98	— —	PDA 12 ¹⁾ 05081
AMD 630/8/4 0.9/3.2 kW ²⁾	03298	680/1420	0.9/3.2	400	3.2/7.1	30	777	60	104	— —	PDA 12 ¹⁾ 05081
AMD 630/8/4 1.1/4.5 kW ²⁾	03299	680/1435	1.1/4.5	400	3.6/9.3	40	777	60	130	— —	PDA 12 ¹⁾ 05081

The angle of attack must be specified when ordering. ¹⁾ Flush-m. version see Switch product page.

²⁾ Performance curves for low speed available on request.

* Δ/Δ Start-up.

Performance curves AMD 630/2

n=2940 1/min

Frequency	Hz	Tot.	125	250	500	1k	2k	4k	8k
L _{WA} 10°		dB(A) 112	84	97	104	108	106	101	92
L _{WA} 20°		dB(A) 114	87	99	107	110	109	104	95
L _{WA} 30°		dB(A) 116	89	101	109	112	111	106	97

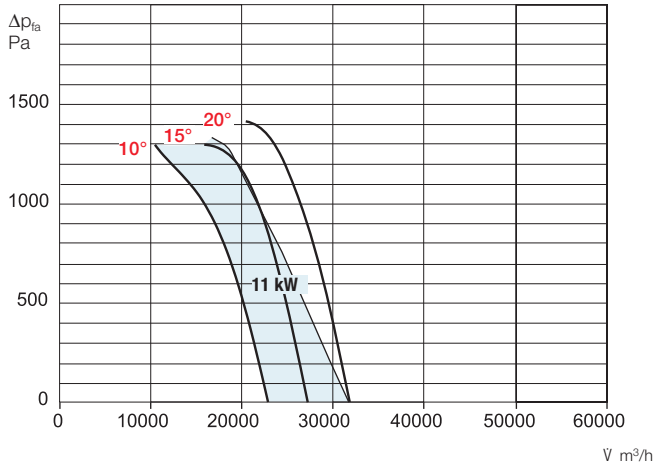

Performance curves AMD 630/4

n=1450 1/min

Frequency	Hz	Tot.	125	250	500	1k	2k	4k	8k
L _{WA} 10°		dB(A) 94	78	87	93	93	90	83	71
L _{WA} 20°		dB(A) 95	79	89	92	94	91	84	72
L _{WA} 30°		dB(A) 97	81	91	95	96	93	86	74

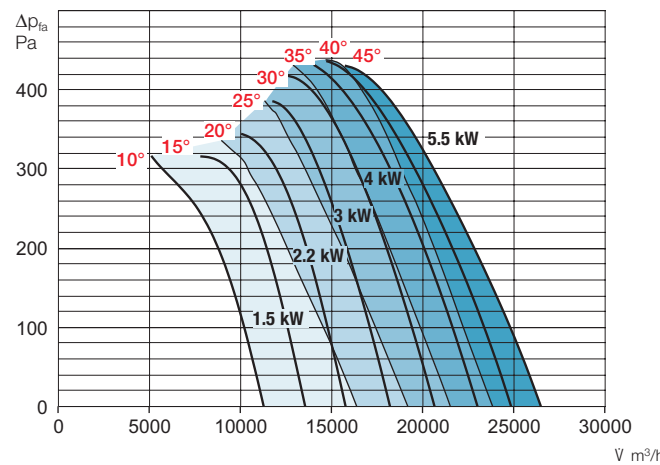

Accessories AMD 630

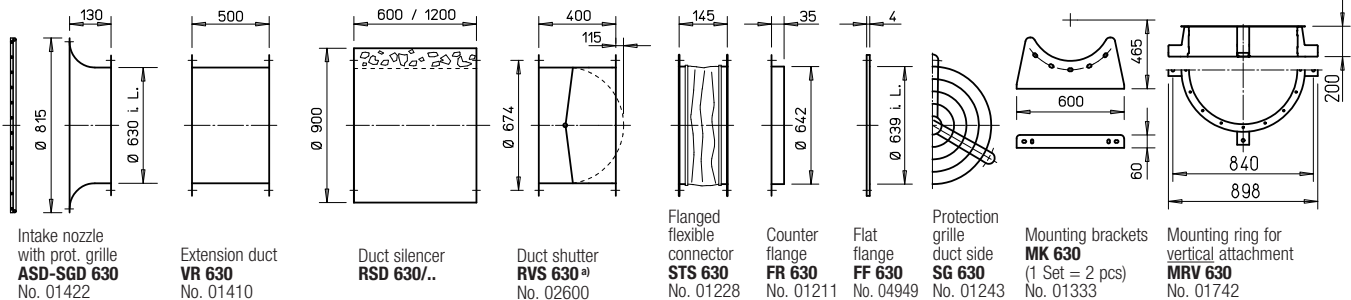

^{a)} Shutter, motorised, see Accessories product page.

Axial and VAR fans

		Vibration dampers	
		Compression	Tension
Type	Ref. no.	Type	Ref. no.
SDD 2	01453	SDZ 2	01455
SDD 2	01453	SDZ 2	01455
SDD 2	01453	SDZ 2	01455
SDD 2	01453	SDZ 2	01455
SDD 2	01453	SDZ 2	01455
SDD 3	01367	SDZ 3	01366
SDD 2	01453	SDZ 2	01455
SDD 2	01453	SDZ 2	01455
SDD 2	01453	SDZ 2	01455

The ideal solution for commercial and industrial applications: **RADAX® VAR.**

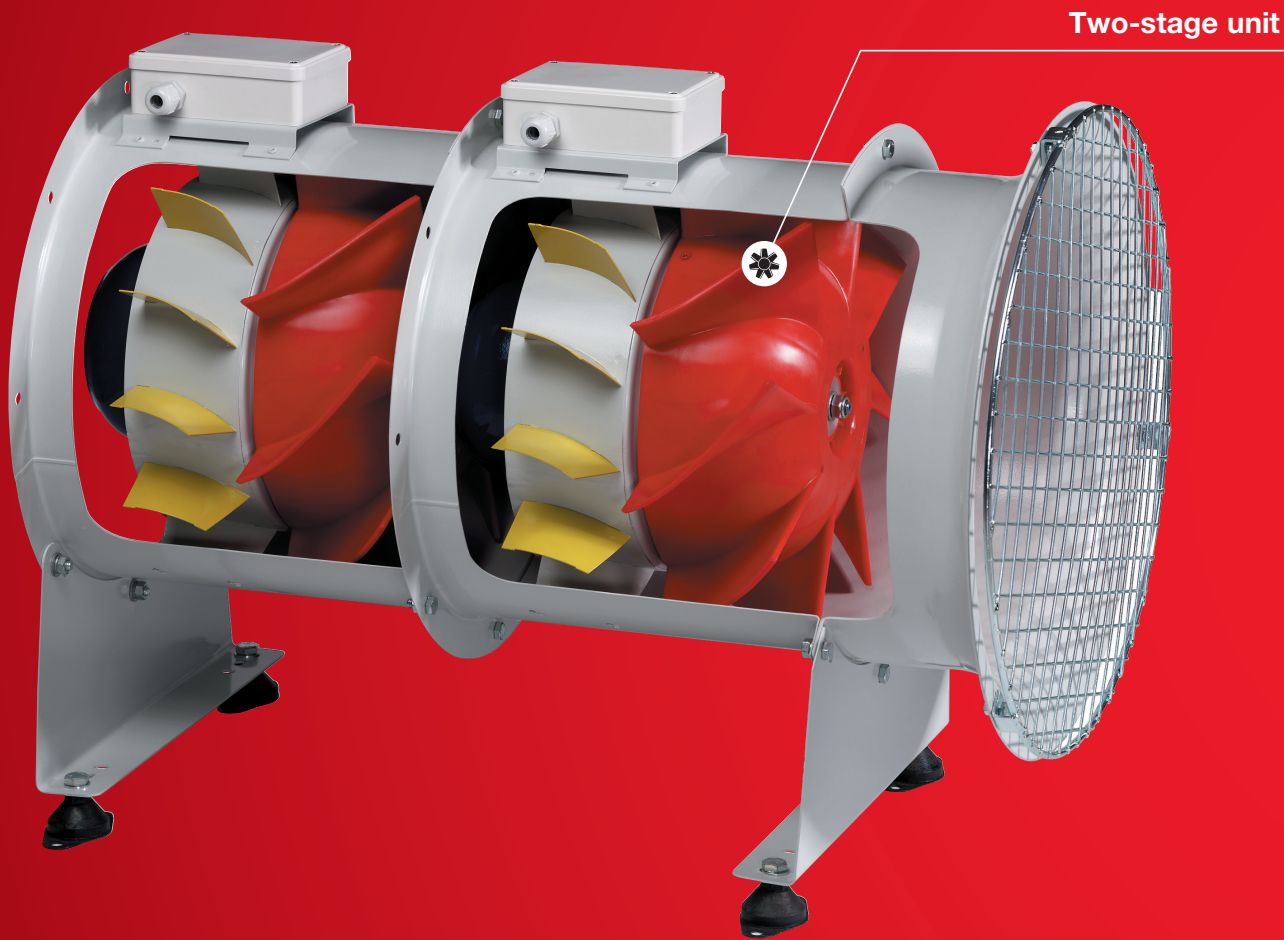

High pressure round duct fans RADAX® VAR are suitable for various commercial and industrial applications. **Almost 150 types in 14 sizes** impress with small and large volume flows and high resistances.

Helios offers the right system for practically any building in combination with perfectly tuned accessory components.





■ Compact

RADAX® VAR impellers offer high pressure and high flow rates, despite their extremely compact casing.

The winning VAR formula lies in the combination of centrifugal fan performance characteristics with an axial flow pattern. The linear air flow improves efficiency and provides a clear reduction in space requirement as well as pipe system savings.

■ High pressure

The synergy of performance and axial flow pattern results in enormous benefits:

- Maximum performance with minimal energy costs.
- Low noise levels.
- High pressure and volume rates with very small dimensions.
- Universal applications.
- Planning freedom.
- No need for on-site deflectors and fittings with associated resistances.
- Low installation costs.

■ Universal

In addition to single-stage types, the RADAX® VAR range offers:

- Other Ø up to 1000 mm.
- B VAR types for smoke extraction according to DIN 12101-3 F300 (60 min.) and F400, F600 (120 min.).
- Parallel units with high volumes and high pressures specifically for the ventilation of garages (VDI 2053).
- Two-stage TwinVent® with the highest pressure rates.

**Request TGA catalogue
Ref. no. 86 979**

This information supplements the “General technical information”.

Features

RADAX® VAR is a series of high pressure round duct fans which ideally combine the advantageous properties of axial and centrifugal fans.

The semiaxial impeller is matched to the fixed guide wheel so that high performance is achieved in pressure and volume flow with a good level of efficiency.

Flow pattern

The axial flow pattern enables a low-loss linear air flow and thus improves the efficiency of the fan. There is no need for the on-site fittings and deflectors required for centrifugal fans and their resistances. This saves installation costs and energy.

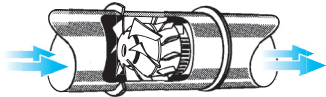

Casing

Tubular casing with double-sided flanges in accordance with DIN 24155, p.3 with integrated guide wheel and motor mount made of galvanised steel. Types with $n = 2800 \text{ min}^{-1}$ in nominal sizes 400, 450, 500 and all types in nominal size 630, welded casing, hot-dip galvanised. Terminal box (IP55) on outside of duct.

Impeller

Semiaxial impeller with 8 spatially curved blades. Made of plastic up to nominal size 355; made of hot-dip galvanised steel for types with $n = 2800 \text{ min}^{-1}$ in nominal size 355 as well as all types in nominal size 400 to 630. Aluminium (extra charge) available upon request. High level of efficiency, low operating noise, high corrosion resistance, low-vibration operation through dynamic balancing in accordance with DIN ISO 21940-11 – quality grade 6.3.

Air flow temperatures

The standard version can be used in the range from $-30 \text{ }^\circ\text{C}$ up to at least $+40 \text{ }^\circ\text{C}$. See information on product page. Approval for higher continuous temperatures is possible upon request.

Explosion protection

The explosion-proof types correspond to unit group II, category 2G for operation in zone 1 and 2. Larger air gaps which result in a performance reduction of approx. 10% are stipulated in accordance with Directive 2014/34/EU (ATEX).

Air flow direction

The air flow direction cannot be changed, but it can be set by the installation method. The correct motor rotation direction and air flow direction is marked by arrows on the fan.

Installation position, installation, condensate outlets

A duct section with length = $2 \times$ pipe diameter for free discharge and a corresponding straight duct section for intermediate positioning in a pipeline are required (Figure 1) to achieve the specified performance values.

- RADAX® VAR can be installed and operated in any position.
 - In case of equipment with condensate drain holes, please be aware of their position.
 - In case of outdoor installation, installation in permanently humid or wet environments or in case of installation with a vertical shaft, this must be indicated when placing the order.
- The installation site and mounting should be such that the fan can be mounted securely and without warping.

Positioning

The use of vibration dampers is recommended (accessories SDD, SDZ) to prevent vibration transmission). Larger motors may protrude from the back and cause uneven distribution due to their high weight. An extension duct VR (accessories) should be provided to adjust the centre of gravity!

Installation examples

- Horizontal**
 - **Figure 2**
Free intake, outlet-side operation. Mounting to ceiling, wall or floor.
 - **Figure 3**
Free intake, outlet-side operation with silencer provided with intermediate flanges. Duct silencers can be provided with intermediate flanges to reduce the inlet-side or outlet-side sound power.
 - **Figure 4**
Ceiling suspension
Figure 4 shows a typical installation in a ventilation application. The installation of VAR systems is possible through direct ceiling or wall suspension without any

Figure 1

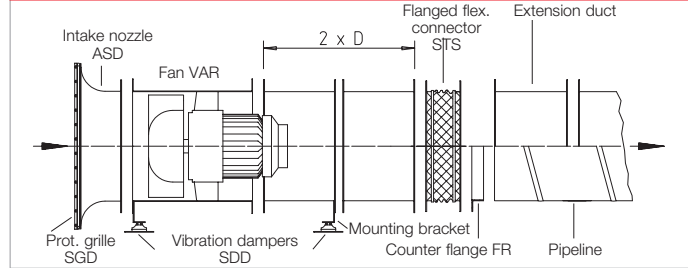

Figure 2

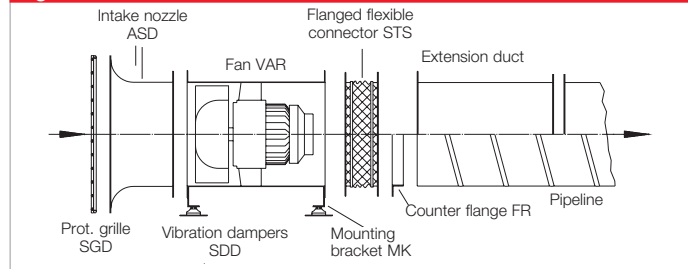

Figure 3

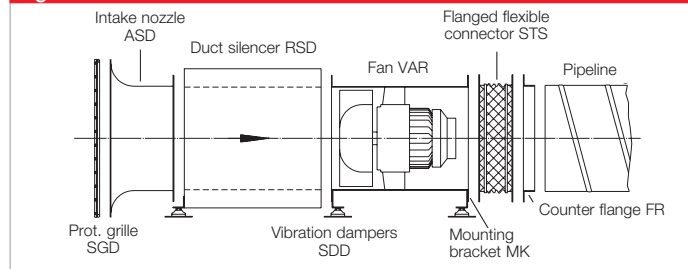
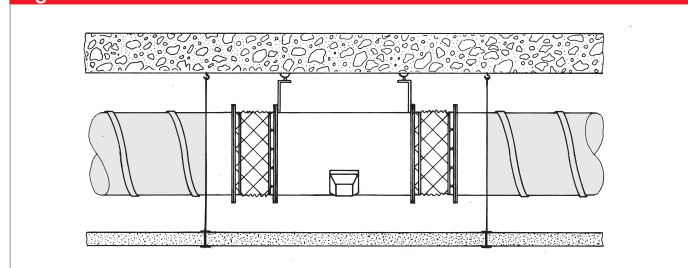

Figure 4



additional expenditure. The tubular casing with double-sided flanges (according to DIN 24155 p. 3) is designed for direct installation in the pipeline.

Vertical

- **Figure 5**
Integrated in the pipeline with inlet-side silencer. Wall mounted with brackets or through the ceiling. The elements must be suspended separately according to weight. Do not mount the fan with combined loads for inspection. Mounting rings MRV are available for the vertical attachment of the fan for size 315 and above. The fan weight including the attached accessories must not exceed the load-bearing capacity of the MRV.

Figure 5

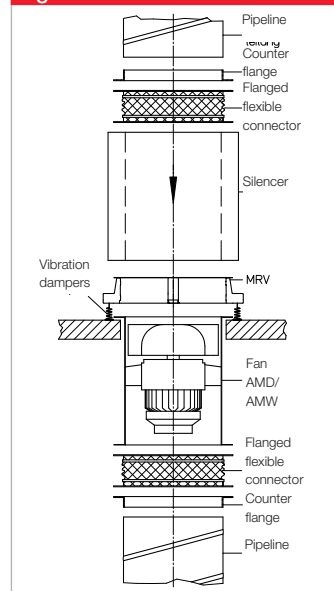

Reference	Page
Planning information, acoustics, expl. protection	14 ff.
General techn. information, power control	19 ff.

By combining the parameters of static pressure increase Δp_{fa} , flow rate V , speed min^{-1} , sound pressure level dB(A) and impeller diameter DN mm, the following table facilitates the selection of

RADAX®-VAR high pressure fans.
 Sizes from \varnothing 710 mm as well as two-stage and parallel VAR systems are available in the TGA catalogue, Ref. no. 86 979.

Diameter mm	Speed min^{-1}	Sound pressure inlet side L_{pa} dB(A) at 4 m distance	Flow rate V m^3/h depending on static pressure = N / m^2 = freely available pressure (Δp_{fa}) in Pa															
			0	50	100	150	200	300	400	500	600	700	800	900	1000			
			225	2800	61	1770	1700	1600	1510	1400								
225	1450	46	900	730														
250	2800	64	2540	2450	2350	2250	2150	1910										
250	1450	49	1250	1050														
280	2800	68	3320	3220	3110	3010	2900	2670	2360									
280	1450	52	1630	1400	1000													
315	2800	71	4670	4550	4430	4310	4200	3930	3650	3280								
315	1450	56	2510	2300	2060	1730												
355	2800	75	7220	7080	6980	6850	6700	6450	6150	5850	5500	5050						
355	1450	60	3540	3300	3050	2750	2200											
400	2800	78	10150	10000	9850	9700	9600	9300	9000	8700	8350	7950	7500	7100	6400			
400	1450	63	5260	4950	4650	4310	3930											
400	930	52	3500	3060	2290													
450	2800	83	14200	14100	13900	13750	13600	13300	12900	12500	12200	11800	11400	10800	10350			
450	1450	67	7280	6950	6650	6300	5900	4800										
450	930	56	4990	4520	3870													

Diameter mm	Speed min^{-1}	Sound pressure inlet side L_{pa} dB(A) at 4 m distance	Flow rate V m^3/h depending on static pressure = N / m^2 = freely available pressure (Δp_{fa}) in Pa															
			0	50	100	150	200	300	400	500	600	700	800	900	1000			
			500	2800	86	22310	21800	21400	20800	20300	19750	19200	18600	17900	16000	13500		
500	1450	70	9700	8640	7300													
500	930	59	6860	5150														
560	1450	73	13550	12500	11300	9850												
560	930	63	9850	8110														
560	725	56	7510															
630	1450	77	21460	20410	19110	17610	15760											
630	930	67	14040	12190	8740													
630	725	60	10690	7810														
Please request separate catalogue for the following performance variables.																		
710	1480	81	31350	30210	28920	27370	25680	23710	20790									
710	950	70	20110	18120	15390													
710	725	64	15330	12380														
800	1480	85	44870	43580	42210	40610	38810	36910	34780	32130	26670							
800	950	74	28770	26640	23850	19970												
800	725	67	21940	18810														
900	1480	88	63890	62450	60940	59300	57440	55410	53310	50990	48420	39610						
900	950	78	40990	38650	35710	32250	26830											
900	725	71	31260	27910	23160													
1000	1480	92	87640	86050	84410	82590	80770	78650	76400	74110	71650	66090	57450					
1000	950	81	56220	53690	50670	47080	42960	36050										
1000	725	74	42880	39330	34590	25090												

Axial and VAR fans

VAR 225



Also available in version:

Dimensions VAR 225

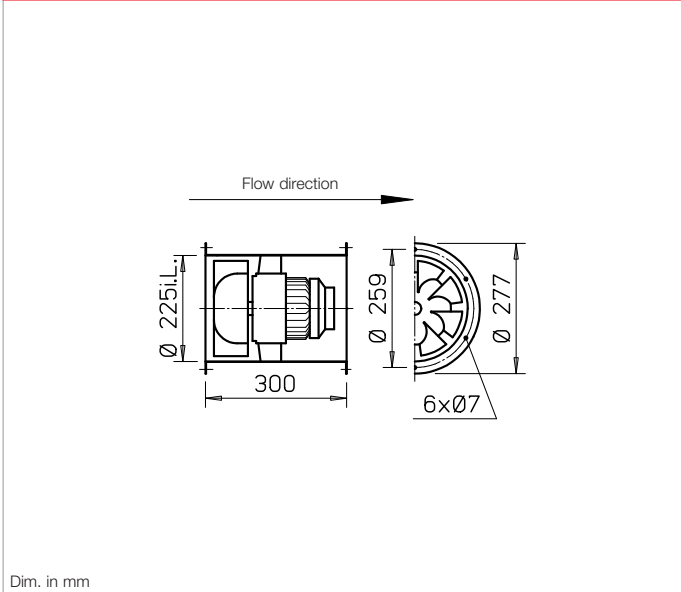

Dim. in mm

■ Casing

Duct with double-sided flange DIN 24155 p. 3. Made of galvanized steel sheet, fixed guide wheel with inner hub for mounting the flange motor.

■ Impeller

Optimised for high pressure and volume performance. Special development with spatially curved blades made of high-quality plastic.

■ Drive

Directly through maintenance-free flange motor. Closed design type IP54. Aluminium casing with cooling fins. Radio interference-free, sealed ball bearings. Tropicalised winding with moisture proof coating. With condensate drain holes upon request (except for explosion-proof types), and the installation method must be indicated when placing the order.

■ Power control

The voltage-controllable types are identified in the "Current consumption with control mode" column with a value which must be observed when determining the controller (see Speed controller column). The flow rates are shown in the performance diagram. The planned use of a frequency inverter without a sine filter should be indicated when placing the order. This requires a change of fan version and additional costs, if necessary. Explosion-proof types are not controllable.

■ Electrical connection

Standard terminal box (protection category IP55) on outside of duct.

■ Installation

Installation possible in any position; but be aware of any condensate drain holes depending on usage.

■ Motor protection

All types (except for 3~ explosion-proof) are equipped with thermal contacts. These should be wired with the motor protection circuit breaker (see type table) for effective motor protection. For 1~ explosion-proof types, the thermal contacts are wired in series with the winding, automatic deactivation and re-activation after cool down. Motors without thermal contacts must be protected by means of on-site a motor protection circuit breaker.

■ Noise levels

See sound power information above performance diagram. The lower sound pressure value can be determined using the diagram on the "Technical information" page. See page 14 f for noise emissions and room acoustics.

■ Reference Page

Techn. description	254
Selection table	255
Planning information	14 ff.

■ Special design

Different voltage, frequency, protection category, higher air flow temperature and acid protection upon request.

The technical information on p. 19 ff. must be observed.

Type	Ref. no.	Speed min ⁻¹	Flow rate free-blow. V m ³ /h	Power consump.* kW	Voltage V	Current consumption*		Wiring diagram No.	Max. air flow temp.		Weight net ca. kg	Speed controller 5-step Pole chang. switch		Motor protection circuit breaker for connecting built-in thermal contacts		Vibration dampers		
						at rated voltage A	with control A		at rated voltage +°C	with control +°C		Type	Ref. no.	Type	Ref. no.	Compr. Type	Tens. Type	
Single-phase alternating current 50 Hz, protection category IP54																		
VARW 225/4	06660	1450	900	0.10	230	0.50	0.55	966	60	40	10.5	MWS 1 ¹⁾ 01947	MW	01579	SDD 1	SDZ 1		
VARW 225/2	06661	2770	1778	0.35	230	1.90	2.50	966	60	40	10.5	MWS 3 ¹⁾ 01948	MW	01579	SDD 1	SDZ 1		
Three-phase current, 50 Hz, protection category IP54																		
VARD 225/4	06662	1420	880	0.10	400 ^γ	0.20	0.20	469	60	40	10.5	RDS 1 ¹⁾ 01314	MD	05849	SDD 1	SDZ 1		
VARD 225/2	06663	2720	1750	0.28	400 ^γ	0.60	0.60	469	60	40	10.5	RDS 1 ¹⁾ 01314	MD	05849	SDD 1	SDZ 1		
Pole-changeable, 2 speeds (Dahlander winding γ/γγ), Three-phase current, 50 Hz, protection category IP54																		
VARD 225/4/2	06771	1460/2800	880/1800	0.06/0.30	400	0.22/0.57	–	472	60	–	10.5	PDA 12 ³⁾ 05081	M 3 ²⁾	01293	SDD 1	SDZ 1		
Ex Ex Explosion-proof, II 2G Ex h IIB T3 Gb, Motor Ex d, alternating current 230 Volt, 50 Hz, protection category IP55																		
VARW 225/4 Ex	06733	1400	950	0.06	230	0.70	–	757	40	–	12.0	not permitted	–	–	SDD 1	SDZ 1		
VARW 225/2 Ex	06734	2650	1780	0.18	230	1.23	–	757	40	–	12.5	not permitted	–	–	SDD 1	SDZ 1		
Ex Ex Explosion-proof, II 2G Ex h IIB + H, T3 Gb, Motor Ex e, three-phase current 400 Volt, 50 Hz, protection category IP55																		
VARD 225/4 Ex	06664	1400	940	0.12	400	0.41	–	470	40	–	12.5	not permitted	not permitted	–	SDD 1	SDZ 1		
VARD 225/2 Ex	06665	2850	1930	0.25	400	0.72	–	470	40	–	12.5	not permitted	not permitted	–	SDD 1	SDZ 1		

* For Ex types: Motor ratings see information on page 20. ¹⁾ incl. motor protection circuit breaker. ²⁾ includes operating and speed switch. ³⁾ Flush-m. version see Switch product page.

⁴⁾ Frequency inverter with integrated sine filter, Type FU-BS 2.5, No. 05459, see FU product page.

Performance curves VAR 225/2

n=2800 1/min

Frequency	Hz	Tot.	125	250	500	1k	2k	4k	8k
L _{WA} Air noise		dB(A)	81	51	62	74	76	72	63
L _{PA, 4m} Air noise		dB(A)	61	31	42	54	56	52	43

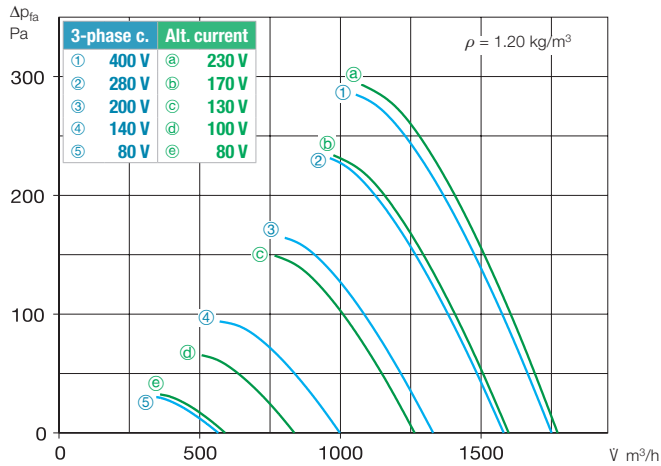

Performance curves VAR 225/4

n=1450 1/min

Frequency	Hz	Tot.	125	250	500	1k	2k	4k	8k
L _{WA} Air noise		dB(A)	66	41	55	60	62	59	43
L _{PA, 4m} Air noise		dB(A)	46	21	35	40	42	39	23

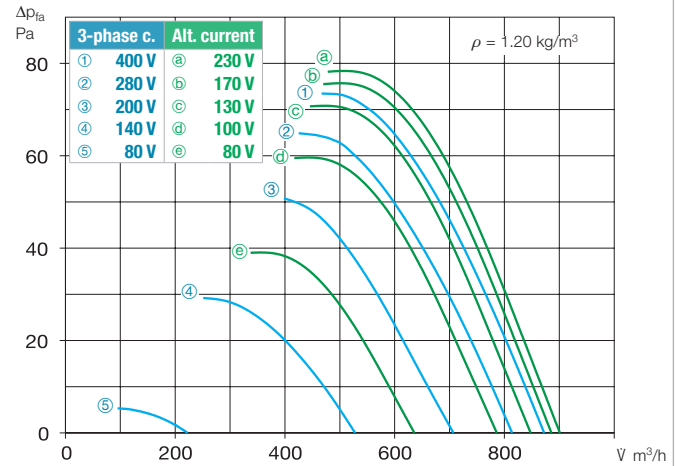

Accessories VAR 225 Description see page 276 ff.

Intake nozzle with prot. grille **ASD-SGD 225** No. 01413

Extension duct **VR 225** No. 01401

Duct silencer-**RSD 225/..**

Duct shutter, automatic **RVS 225^{a)}** No. 02591

Flanged flexible connector **STS 225^{b)}** No. 01218

Counter flange **FR 225** No. 01201

Flexible connecting sleeve **FM 225^{b)}** No. 01671

Protection grille duct side **SG 225** No. 01215

Mounting brackets **MK 225** (1 Set = 2 pcs) No. 01446

Vibration dampers for tensile load **SDZ 1** (1 set = 4 Pc) No. 01454

Vibration dampers for compression load **SDD 1** (1 set = 4 Pc) No. 01452

^{a)} Shutter, motorised see Accessories product pages. ^{b)} Types for explosion-proof fans see above.

Axial and VAR fans

Other accessories	Page
^{b)} Access. for expl.-proof fans	
Flanged flexible connector STS 225 Ex	Ref. no. 02500
Flexible connecting sleeve FM 225 Ex	Ref. no. 01687
Filters and silencers	481 ff.
Shutters and ventilation grilles	561 ff.
Speed controllers, controllers and switches	599 ff.

VAR 250



Also available in version:

Dimensions VAR 250

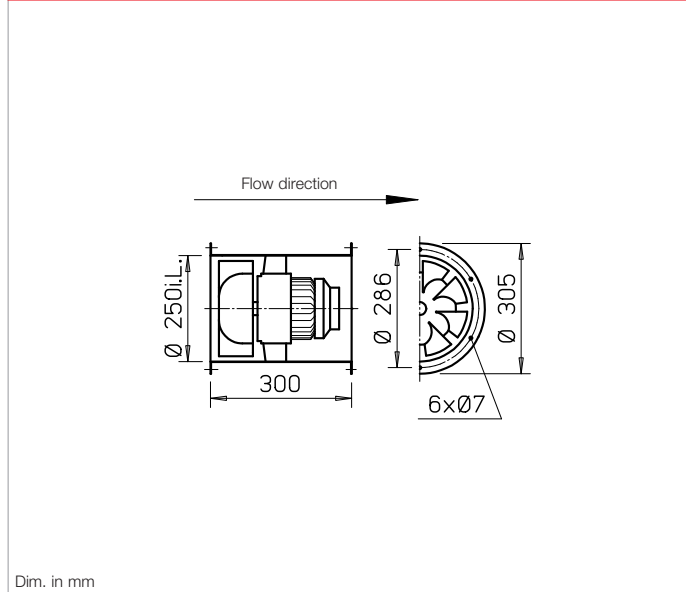

Dim. in mm

■ Casing

Duct with double-sided flange DIN 24155 p. 3. Made of galvanised steel sheet, fixed guide wheel with inner hub for mounting the flange motor.

■ Impeller

Optimised for high pressure and volume performance. Special development with spatially curved blades made of high-quality plastic.

■ Drive

Directly through maintenance-free flange motor. Closed design type IP54. Aluminium casing with cooling fins. Radio interference-free, sealed ball bearings. Tropicalised winding with moisture proof coating. With condensate drain holes upon request (except for explosion-proof types), and the installation method must be indicated when placing the order.

■ Power control

The voltage-controllable types are identified in the "Current consumption with control mode" column with a value which must be observed when determining the controller (see Speed controller column). The flow rates are shown in the performance diagram. The planned use of a frequency inverter without a sine filter should be indicated when placing the order. This requires a change of fan version and additional costs, if necessary. Explosion-proof types are not controllable.

■ Electrical connection

Standard terminal box (protection category IP55) on outside of duct.

■ Installation

Installation possible in any position; but be aware of any condensate drain holes depending on usage.

■ Motor protection

All types (except for 3~ explosion-proof) are equipped with thermal contacts. These should be wired with the motor protection circuit breaker (see type table) for effective motor protection. For 1~ explosion-proof types, the thermal contacts are wired in series with the winding, automatic deactivation and re-activation after cool down. Motors without thermal contacts must be protected by means of on-site a motor protection circuit breaker.

■ Noise levels

See sound power information above performance diagram. The lower sound pressure value can be determined using the diagram on the "Technical information" page. See page 14 f for noise emissions and room acoustics.

Reference	Page
Techn. description	254
Selection table	255
Planning information	14 ff.

Special design

Different voltage, frequency, protection category, higher air flow temperature and acid protection upon request.

The technical information on p. 19 ff. must be observed.

Type	Ref. no.	Speed	Flow rate free-blow.	Power consump.*	Voltage	Current consumption*		Wiring diagram	Max. air flow temp.		Weight net	Speed controller		Motor protection circuit breaker for connecting built-in thermal contacts		Vibration dampers		
						at rated voltage	with control		at rated voltage	with control		Type	Ref. no.	Type	Ref. no.	Compr.	Tens.	
													Type	Ref. no.	Type	Ref. no.	Type	Type
Single-phase alternating current, 50 Hz, protection category IP54																		
VAR 250/4	06666	1420	1210	0.12	230	0.46	0.60	966	60	40	11.5	MWS 1.5 ¹⁾ 01947	MW	01579	SDD 1	SDZ 1		
VAR 250/2	06667	2840	2540	0.55	230	2.60	3.90	966	60	40	13.0	MWS 5 ¹⁾ 01949	MW	01579	SDD 1	SDZ 1		
Three-phase current, 50 Hz, protection category IP54																		
VARD 250/4	06668	1410	1250	0.09	400	0.30	0.30	469	60	40	11.5	RDS 1 ¹⁾ 01314	MD	05849	SDD 1	SDZ 1		
VARD 250/2	06669	2800	2450	0.47	400	1.10	1.10	469	60	40	11.5	RDS 2 ¹⁾ 01315	MD	05849	SDD 1	SDZ 1		
													Pole chang. switch					
Pole-changeable, 2 speeds (Dahlander winding γ/γ), Three-phase current, 50 Hz, protection category IP54																		
VAR 250/4/2	06773	1425/2750	1200/2400	0.75/0.49	400	0.24/0.94	–	472	60	–	13.0	PDA 12 ³⁾ 05081	M 3 ²⁾	01293	SDD 1	SDZ 1		
Ex Explosion-proof, II 2G Ex h IIB T3 Gb, Motor Ex d, alternating current 230 Volt, 50 Hz, protection category IP55																		
VAR 250/4 Ex	06735	1400	1290	0.06	230	0.70	–	757	40	–	13.0	not permitted	–	–	SDD 1	SDZ 1		
Ex Explosion-proof, II 2G Ex h IIB + H₂ T3 Gb, Motor Ex e, three-phase current 400 Volt, 50 Hz, protection category IP55																		
VARD 250/4 Ex	06670	1355	1300	0.12	400	0.37	–	470	40	–	13.0	not permitted	not permitted	–	SDD 1	SDZ 1		
VAR 250/2 Ex	06671	2800	2590	0.25	400	0.75	–	470	40	–	15.5	not permitted	not permitted	–	SDD 1	SDZ 1		

* For Ex types: Motor ratings see information on page 20. ¹⁾ incl. motor protection circuit breaker. ²⁾ includes operating and speed switch. ³⁾ Flush-m. version see Switch product page.

⁴⁾ Frequency inverter with integrated sine filter, Type FU-BS 2.5, No. 05459, see product page FU.

Performance curves VAR 250/2

n=2800 1/min

Frequency	Hz	Tot.	125	250	500	1k	2k	4k	8k	
L _{WA}	Air noise	dB(A)	84	55	65	77	79	80	75	67
L _{PA,4m}	Air noise	dB(A)	64	35	45	57	59	60	55	47

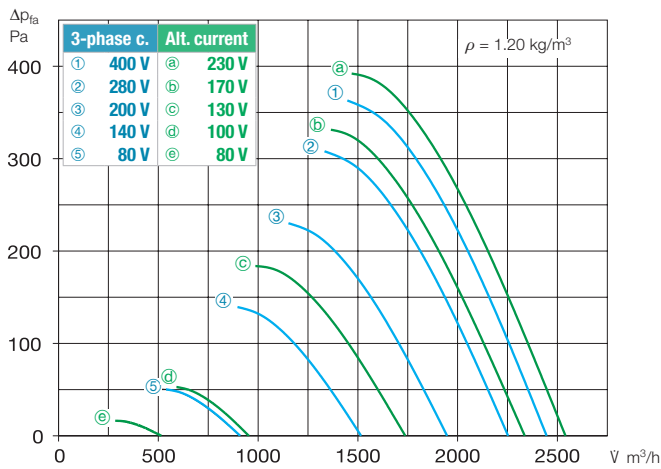

Performance curves VAR 250/4

n=1450 1/min

Frequency	Hz	Tot.	125	250	500	1k	2k	4k	8k	
L _{WA}	Air noise	dB(A)	69	44	58	63	65	63	56	46
L _{PA,4m}	Air noise	dB(A)	49	24	38	43	45	43	36	26

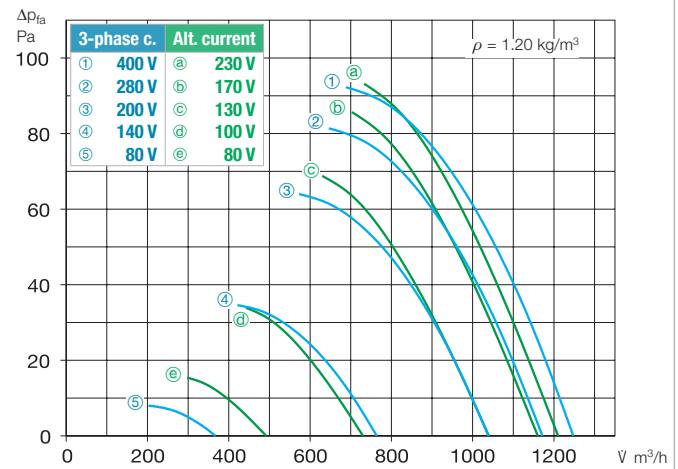

Accessories VAR 250 Description see page 276 ff.

Intake nozzle with prot. grille ASD-SGD 250 No. 01414	Extension duct VR 250 No. 01402	Duct silencer- RSD 250/..	Duct shutter, auto- matic RVS 250^{a)} No. 02592	Flanged flexible connector STS 250^{b)} No. 01220	Counter flange FR 250 No. 01203	Flat flange FF 250 No. 04941	Flexible connecting sleeve FM 250^{b)} No. 01672	Protection grille duct side SG 250 No. 01236	Mounting brackets MK 250 (1 Set = 2 pcs) No. 01447	Vibration dampers for tensile load SDZ 1 (1 set = 4 Pc) No. 01454 Vibration dampers for compression load SDD 1 (1 set = 4 Pc) No. 01452
--	--	-------------------------------------	--	--	--	---	---	---	--	--

^{a)} Shutter, motorised see Accessories product pages. ^{b)} Types for explosion-proof fans see above.

Axial and VAR fans

Other accessories	Page
^{b)} Access. for expl.-proof fans	
Flanged flexible connector STS 250 Ex	Ref. no. 02501
Flexible connecting sleeve FM 250 Ex	Ref. no. 01688
Filters and silencers	481 ff.
Shutters and ventilation grilles	561 ff.
Speed controllers, controllers and switches	599 ff.

VAR 280



Also available in version:

Dimensions VAR 280

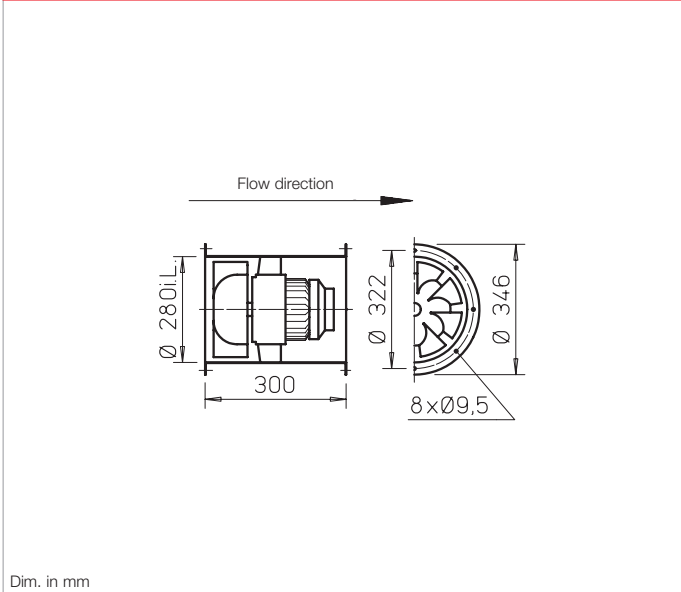

Dim. in mm

■ Casing

Duct with double-sided flange DIN 24155 p. 3. Made of galvanised steel sheet, fixed guide wheel with inner hub for mounting the flange motor.

■ Impeller

Optimised for high pressure and volume performance. Special development with spatially curved blades made of high-quality plastic.

■ Drive

Directly through maintenance-free flange motor. Closed design type IP54. Aluminium casing with cooling fins. Radio interference-free, sealed ball bearings. Tropicalised winding with moisture proof coating. With condensate drain holes upon request (except for explosion-proof types), and the installation method must be indicated when placing the order.

■ Power control

The voltage-controllable types are identified in the "Current consumption with control mode" column with a value which must be observed when determining the controller (see Speed controller column). The flow rates are shown in the performance diagram. The planned use of a frequency inverter without a sine filter should be indicated when placing the order. This requires a change of fan version and additional costs, if necessary. Explosion-proof types are not controllable.

■ Electrical connection

Standard terminal box (protection category IP55) on outside of duct.

■ Installation

Installation possible in any position; but be aware of any condensate drain holes depending on usage.

■ Motor protection

All types (except for 3~ explosion-proof) are equipped with thermal contacts. These should be wired with the motor protection circuit breaker (see type table) for effective motor protection. For 1~ explosion-proof types, the thermal contacts are wired in series with the winding, automatic deactivation and re-activation after cool down. Motors without thermal contacts must be protected by means of on-site a motor protection circuit breaker.

■ Noise levels

See sound power information above performance diagram. The lower sound pressure value can be determined using the diagram on the "Technical information" page. See page 14 f for noise emissions and room acoustics.

Reference	Page
Techn. description	254
Selection table	255
Planning information	14 ff.

Special design

Different voltage, frequency, protection category, higher air flow temperature and acid protection upon request.

The technical information on p. 19 ff. must be observed.

Type	Ref. no.	Speed	Flow rate free-blow.	Power consump.*	Voltage	Current consumption*		Wiring diagram	Max. air flow temp.		Weight net	Speed controller		Motor protection circuit breaker for connecting built-in thermal contacts		Vibration dampers		
						at rated voltage	with control		at rated voltage	with control		Type	Ref. no.	Type	Ref. no.	Compr.	Tens.	
													Type	Ref. no.	Type	Ref. no.	Type	Type
Single-phase alternating current, 50 Hz, protection category IP54																		
VARW 280/4	06672	1330	1600	0.11	230	0.50	0.60	966	60	40	12.0	MWS 1.5 ¹⁾ 01947	MW	01579	SDD 1	SDZ 1		
VARW 280/2	06659	2715	3350	0.79	230	3.70	4.90	967	60	40	14.0	MWS 7.5 ¹⁾ 01950	MW	01579	SDD 1	SDZ 1		
Three-phase current, 50 Hz, protection category IP54																		
VARD 280/4	06673	1370	1650	0.12	400	0.35	0.35	469	60	40	12.0	RDS 1 ¹⁾ 4) 01314	MD	05849	SDD 1	SDZ 1		
VARD 280/2	06674	2705	3315	0.80	400	1.52	1.64	469	60	40	13.5	RDS 2 ¹⁾ 4) 01315	MD	05849	SDD 1	SDZ 1		
													Pole change switch					
VARW 280/4/2	06775	1405/2810	1760/3500	0.14/0.91	400	0.44/1.78	–	472	60	–	16.0	PDA 12 ³⁾ 05081	M 3 ²⁾	01293	SDD 1	SDZ 1		
Explosion-proof, II 2G Ex h IIB T3 Gb, Motor Ex d, alternating current 230 Volt, 50 Hz, protection category IP55																		
VARW 280/4 Ex	06737	1330	1720	0.18	230	1.25	–	757	40	–	14.0	not permitted	–	–	SDD 1	SDZ 1		
Explosion-proof, II 2G Ex h IIB + H₂ T3 Gb, Motor Ex e, three-phase current 400 Volt, 50 Hz, protection category IP55																		
VARD 280/4 Ex	06675	1355	1820	0.12	400	0.37	–	470	40	–	16.0	not permitted	not permitted	SDD 1	SDZ 1			
VARD 280/2 Ex	06676	2885	3720	0.75	400	1.59	–	470	40	–	18.0	not permitted	not permitted	SDD 1	SDZ 1			

* For Ex types: Motor ratings see information on page 20. ¹⁾ incl. motor protection circuit breaker. ²⁾ includes operating and speed switch. ³⁾ Flush-m. version see Switch product page.

⁴⁾ Frequency inverter with integrated sine filter, Type FU-BS 2.5, No. 05459, see product page FU.

Performance curves VAR 280/2

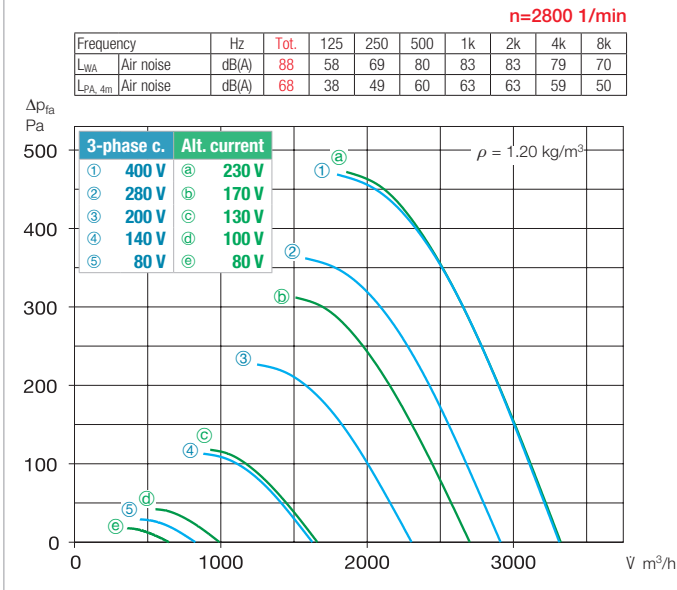

Performance curves VAR 280/4

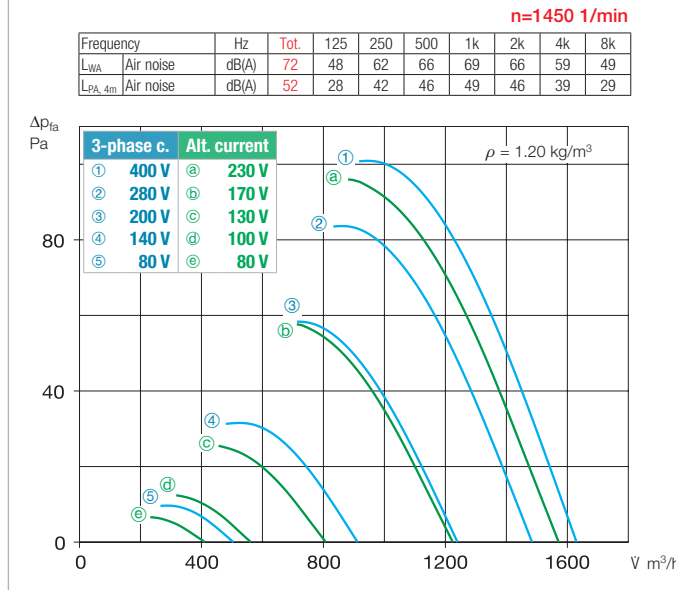

Accessories VAR 280 Description see page 276 ff.

Intake nozzle with prot. grille ASD-SGD 280 No. 01415	Extension duct VR 280 No. 01403	Duct silencer- RSD 280/..	Duct shutter, auto-matic RVS 280 a) No. 02593	Flanged flexible connector STS 280 b) No. 01231	Counter flange FR 280 No. 01214	Flat flange FF 280 No. 04942	Flexible connecting sleeve FM 280 b) No. 01673	Protection grille duct side SG 280 No. 01428	Mounting brackets MK 280 (1 Set = 2 pcs) No. 01447	Vibration dampers for tensile load SDZ 1 (1 set = 4 Pc) No. 01454 Vibration dampers for compression load SDD 1 (1 set = 4 Pc) No. 01452
--	--	-------------------------------------	--	--	--	---	---	---	--	--

a) Shutter, motorised see Accessories product pages. b) Types for explosion-proof fans see above.

Axial and VAR fans

Other accessories	Page
Access. for expl.-proof fans	
Flanged flexible connector STS 280 Ex	Ref. no. 02502
Flexible connecting sleeve FM 280 Ex	Ref. no. 01689
Filters and silencers	481 ff.
Shutters and ventilation grilles	561 ff.
Speed controllers, controllers and switches	599 ff.

VAR 315



Also available in version:

Dimensions VAR 315

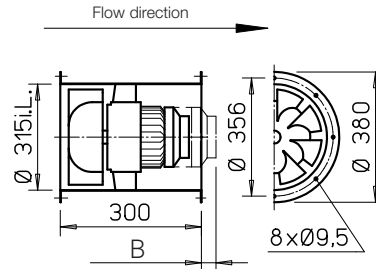

Dim. B see table
 Dim. in mm

Casing

Duct with double-sided flange DIN 24155 p. 3. Made of galvanised steel sheet, fixed guide wheel with inner hub for mounting the flange motor.

Impeller

Optimised for high pressure and volume performance. Special development with spatially curved blades made of high-quality plastic.

Drive

Directly through maintenance-free flange motor. Closed design type IP54. Aluminium casing with cooling fins. Radio interference-free, sealed ball bearings. Tropicalised winding with moisture proof coating. With condensate drain holes upon request (except for explosion-proof types), and the installation method must be indicated when placing the order.

Power control

The voltage-controllable types are identified in the "Current consumption with control mode" column with a value which must be observed when determining the controller (see Speed controller column). The flow rates are shown in the performance diagram. The planned use of a frequency inverter without a sine filter should be indicated when placing the order. This requires a change of fan version and additional costs, if necessary. Explosion-proof types are not controllable.

Electrical connection

Standard terminal box (protection category IP55) on outside of duct.

Installation

Installation possible in any position; but be aware of any condensate drain holes depending on usage.

Motor protection

All types (except for 3~ explosion-proof) are equipped with thermal contacts. These should be wired with the motor protection circuit breaker (see type table) for effective motor protection. For 1~ explosion-proof types, the thermal contacts are wired in series with the winding, automatic deactivation and re-activation after cool down. Motors without thermal contacts must be protected by means of on-site a motor protection circuit breaker.

Noise levels

See sound power information above performance diagram. The lower sound pressure value can be determined using the diagram on the "Technical information" page. See page 14 f for noise emissions and room acoustics.

Reference Page

Techn. description	254
Selection table	255
Planning information	14 ff.

Special design

Different voltage, frequency, protection category, higher air flow temperature and acid protection upon request.

The technical information on p. 19 ff. must be observed.

Type	Ref. no.	Speed min ⁻¹	Flow rate free-blow. V m ³ /h	Power consump.* kW	Voltage V	Current consumption*		Wiring diagram No.	Max. air flow temp.		Weight net ca. kg	Dim. B Motor protru- sion mm	Speed controller 5-step Pole chang. switch		Motor pro- tection circuit breaker for connecting built-in thermal contacts		Vibration dampers		
						at rated voltage A	with control A		at rated voltage +°C	with control +°C			Type	Ref. no.	Type	No.	Compr. Type	Tens. Type	
Single-phase alternating current, 50 Hz, protection category IP54																			
VARW 315/4	06677	1440	2480	0.23	230	1.10	1.17	966	60	40	13.0	–	MWS 3 ¹⁾	01948	MW	01579	SDD 1	SDZ 1	
Three-phase current, 50 Hz, protection category IP54																			
VARD 315/4	06678	1450	2510	0.22	400	0.60	0.70	469	60	40	13.0	–	RDS 1 ¹⁾⁴⁾	01314	MD	05849	SDD 1	SDZ 1	
Two-speed, three-phase current, 50 Hz, Y/Δ connection, protection category IP54																			
VARW 315/2/2	06679	2150/2650	3580/4670	0.9/1.35	400Y/Δ	1.5/2.4	2.5	520	60	40	20.5	66	RDS 4 ¹⁾	01316	M 4 ²⁾	01571	SDD 1	SDZ 1	
Pole-changeable, 2 speeds (Dahlander winding Y/Y), Three-phase current, 50 Hz, protection category IP54																			
VARW 315/4/2	06777	1480/2890	2730/5340	0.42/1.83	400	1.2/3.3	–	472	60	–	20.5	54	PDA 12 ³⁾	05081	–	–	SDD 1	SDZ 1	
Ex Ex Explosion-proof, II 2G Ex h IIB T3 Gb, Motor Ex d, alternating current 230 Volt, 50 Hz, protection category IP55																			
VARW 315/4 Ex	06738	1450	2680	0.18	230	1.25	–	757	40	–	15.0	6	not permitted	–	–	–	SDD 1	SDZ 1	
Ex Ex Explosion-proof, II 2G Ex h IIB + H₂ T3 Gb, Motor Ex e, three-phase current 400 Volt, 50 Hz, protection category IP55																			
VARD 315/4 Ex	06680	1420	2610	0.37	400	1.08	–	470	40	–	17.0	–	not permitted	not permitted	–	–	SDD 1	SDZ 1	
VARW 315/2 Ex	06681	2860	5260	1.50	400	3.15	–	470	40	–	23.0	44	not permitted	not permitted	–	–	SDD 1	SDZ 1	

* For Ex types: Motor ratings see information on page 20. ¹⁾ incl. motor protection circuit breaker. ²⁾ includes operating and speed switch. ³⁾ Flush-m. version see Switch product page.

⁴⁾ Frequency inverter with integrated sine filter, Type FU-BS 2.5, No. 05459, see product page FU.

Performance curves VAR 315/2

n=2700 1/min

Frequency	Hz	Tot.	125	250	500	1k	2k	4k	8k	
L _{WA} Air noise		dB(A)	91	62	73	84	86	87	82	74
L _{PA,4m} Air noise		dB(A)	71	42	53	64	66	67	62	54

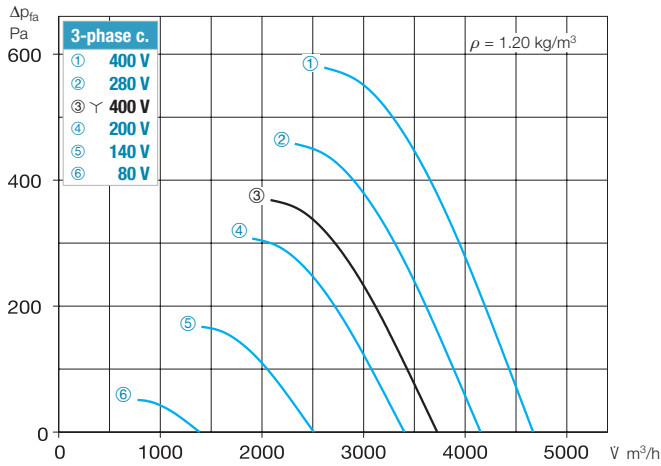

Performance curves VAR 315/4

n=1450 1/min

Frequency	Hz	Tot.	125	250	500	1k	2k	4k	8k	
L _{WA} Air noise		dB(A)	76	52	65	70	72	70	63	53
L _{PA,4m} Air noise		dB(A)	56	32	45	50	52	50	43	33

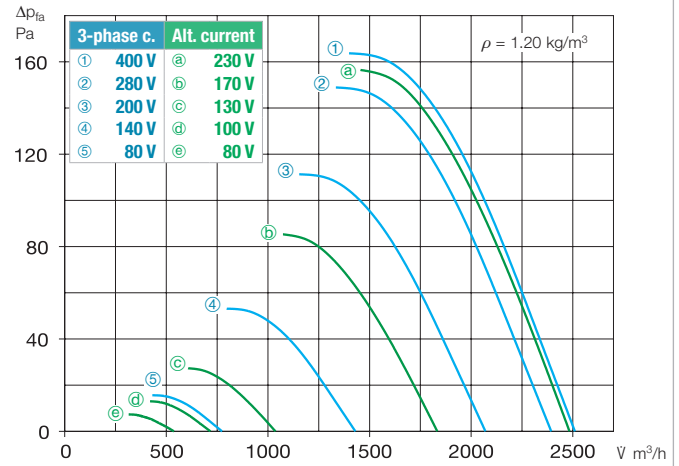

Accessories VAR 315 Description see page 276 ff.

Intake nozzle with prot. grille ASD-SGD 315 No. 01416	Extension duct VR 315 No. 01404	Duct silencer- RSD 315/..	Duct shutter, automatic RVS 315 a) No. 02594	Flanged flexible connector STS 315 b) No. 01221	Counter flange FR 315 No. 01204	Flat flange FF 315 No. 04943	Flexible connecting sleeve FM 315 b) No. 01674	Protection grille duct side SG 315 No. 01237	Mounting brackets MK 315 (1 Set = 2 pcs) No. 01448	Mounting ring for vertical attachment MRV 315 No. 01755

a) Shutter, motorised see Accessories product pages. b) Types for explosion-proof fans see above.

Axial and VAR fans

Other accessories	Page
Access. for expl.-proof fans	
Flanged flexible connector STS 315 Ex	Ref. no. 02503
Flexible connecting sleeve FM 315 Ex	Ref. no. 01690
Filters and silencers	481 ff.
Shutters and ventilation grilles	561 ff.
Speed controllers, controllers and switches	599 ff.

VAR 355



Also available in version:

Dimensions VAR 355

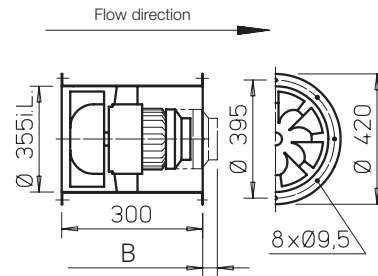

Dim. B see table
 Dim. in mm

Casing

Duct with double-sided flange DIN 24155 p. 3. Made of galvanised steel sheet, fixed guide wheel with inner hub for mounting the flange motor.

Impeller

Optimised for high pressure and volume performance. Special development with spatially curved blades made of high-quality plastic; made of hot-dip galvanised steel for types with $n = 2800 \text{ min}^{-1}$.

Drive

Directly through maintenance-free flange motor. Closed design type IP54. Aluminium casing with cooling fins. Radio interference-free, sealed ball bearings. Tropicalised winding with moisture proof coating. With condensate drain holes upon request (except for explosion-proof types), and the installation method must be indicated when placing the order.

Power control

The voltage-controllable types are identified in the "Current consumption with control mode" column with a value which must be observed when determining the controller (see Speed controller column). The flow rates are shown in the performance diagram. The planned use of a frequency inverter without a sine filter should be indicated when placing the order. This requires a change of fan version and additional costs, if necessary. Explosion-proof types are not controllable.

Electrical connection

Standard terminal box (protection category IP55) on outside of duct.

Installation

Installation possible in any position; but be aware of any condensate drain holes depending on usage.

Motor protection

All types (except for explosion-proof models and type VARD 355/4/2) are equipped with thermal contacts. These should be wired with the motor protection circuit breaker (see type table) for effective motor protection. Motors without thermal contacts must be protected by means of on-site a motor protection circuit breaker.

Noise levels

See sound power information above performance diagram. The lower sound pressure value can be determined using the diagram on the "Technical information" page. See page 14 f for noise emissions and room acoustics.

Reference	Page
Techn. description	254
Selection table	255
Planning information	14 ff.

Special design

Different voltage, frequency, protection category, higher air flow temperature and acid protection upon request.

The technical information on p. 19 ff. must be observed.

Type	Ref. no.	Speed min ⁻¹	Flow rate free-blow. V m ³ /h	Power consump.* kW	Voltage V	Current consumption*		Wiring diagram No.	Max. air flow temp.		Weight net ca. kg	Dim. B Motor protru- sion mm	Speed controller 5-step Pole chang. switch		Motor pro- tection circuit breaker for connecting built-in thermal contacts		Vibration dampers		
						at rated voltage A	with control A		at rated voltage +°C	with control +°C			Type	Ref. no.	Type	No.	Compr. Type	Tens. Type	
Single-phase alternating current, 50 Hz, protection category IP54																			
VARW 355/4	06682	1380	3470	0.37	230	3.30	2.35	966	60	40	21.0	22	MWS 3 ¹⁾	01948	MW	01579	SDD 1	SDZ 1	
Three-phase current, 50 Hz, protection category IP54																			
VARD 355/4	06683	1440	3550	0.40	400	0.87	1.20	469	60	40	15.5	12	RDS 1 ^{1) 2)}	01314	MD	05849	SDD 1	SDZ 1	
Two-speed, three-phase current, 50 Hz, γ/Δ connection, protection category IP54																			
VARD 355/2/2	06684	2415/2790	6040/7220	2.06/2.81	400 γ/Δ	3.40/5.40	–	520	60	30	30.3	94	RDS 7 ¹⁾	01578	M 4 ²⁾	01571	SDD 1	SDZ 1	
Pole-changeable, 2 speeds (Dahlander winding $\gamma/\gamma\gamma$), Three-phase current, 50 Hz, protection category IP54																			
VARD 355/4/2	06779	1470/2870	3830/7500	0.48/3.11	400	1.35/5.50	–	471	40	–	29.0	80	PDA 12 ³⁾	05081	–	–	SDD 1	SDZ 1	
Ex	Explosion-proof, II 2G Ex h IIB + H₂ T3 Gb, Motor Ex e, three-phase current 400 Volt, 50 Hz, protection category IP55																		
VARD 355/4 Ex	06685	1420	3740	0.37	400	1.08	–	470	40	–	19.0	–	–	–	–	–	SDD 1	SDZ 1	
Ex	Explosion-proof, II 2G Ex h IIB T3 Gb, Motor Ex e, three-phase current 400 Volt, 50 Hz, protection category IP55																		
VARD 355/2 Ex ⁴⁾	06686	2910	7580	2.50	400	4.90	–	498	40	–	33.0	77	–	–	–	–	SDD 1	SDZ 1	

* For Ex types: Motor ratings see information on page 20. ¹⁾ incl. motor protection circuit breaker. ²⁾ includes operating and speed switch. ³⁾ Flush-m. version see Switch product page.
⁴⁾ A vibration monitoring system (on-site) must be provided according to DIN EN 14986. ⁵⁾ Frequency inverter with integrated sine filter, Type FU-BS 2.5, No. 05459, see product page FU.

Performance curves VAR 355/2

n=2800 1/min

Frequency	Hz	Tot.	125	250	500	1k	2k	4k	8k	
L _{WA} Air noise		dB(A)	95	65	76	88	90	90	86	77
L _{PA, 4m} Air noise		dB(A)	75	45	56	68	70	70	66	57

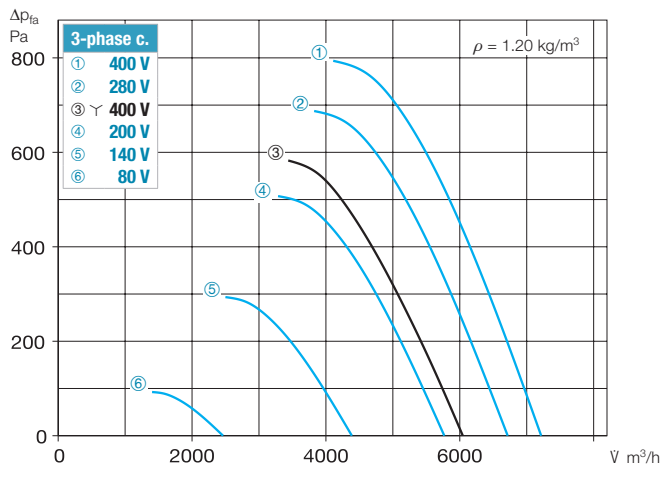

Performance curves VAR 355/4

n=1400 1/min

Frequency	Hz	Tot.	125	250	500	1k	2k	4k	8k	
L _{WA} Air noise		dB(A)	80	55	69	73	76	73	66	56
L _{PA, 4m} Air noise		dB(A)	60	35	49	53	56	53	46	36

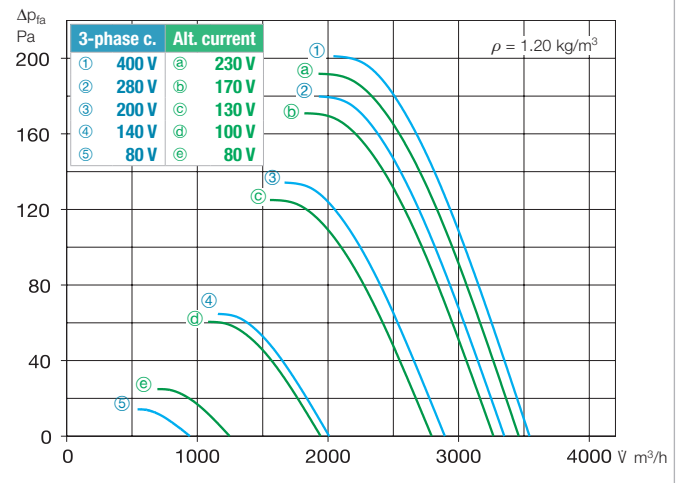

Accessories VAR 355 Description see page 276 ff.

Intake nozzle with prot. grille ASD-SGD 355 No. 01417	Extension duct VR 355 No. 01405	Duct silencer- RSD 355/..	Duct shutter, auto- matic RVS 355 a) No. 02595	Flanged flexible connector STS 355 b) No. 01222	Counter flange FR 355 No. 01205	Flat flange FF 355 No. 04944	Flexible connecting sleeve FM 355 b) No. 01675	Protection grille duct side SG 355 No. 01238	Mounting brackets MK 355 (1 Set = 2 pcs) No. 01448	Mounting ring for vertical attachment MRV 355 No. 01759

a) Shutter, motorised see Accessories product pages. b) Types for explosion-proof fans see above.

Axial and VAR fans

Other accessories	Page
Access. for expl.-proof fans	
Flanged flexible connector STS 355 Ex	Ref. no. 02504
Flexible connecting sleeve FM 355 Ex	Ref. no. 01691
Filters and silencers	481 ff.
Shutters and ventilation grilles	561 ff.
Speed controllers, controllers and switches	599 ff.

VAR 400



Also available in version:

Dimensions VAR 400

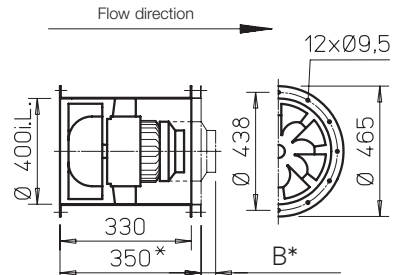

* only for n = 2800 1/min

Dim. B see table
 Dim. in mm

Casing

Duct with double-sided flange DIN 24155 p. 3. Made of galvanized steel sheet, fixed guide wheel with inner hub for mounting the flange motor. Types with n = 2800 min⁻¹ welded casing, hot-dip galvanized.

Impeller

Optimised for high pressure and volume performance. Special development with spatially curved blades made of hot-dip galvanized steel.

Drive

Directly through maintenance-free flange motor. Closed design type IP54. Aluminium or grey cast iron casing with cooling fins. Radio interference-free, sealed ball bearings. Tropicalised winding with moisture proof coating. With condensate drain holes upon request (except for explosion-proof types), and the installation method must be indicated when placing the order.

Power control

The voltage-controllable types are identified in the "Current consumption with control mode" column with a value which must be observed when determining the controller (see Speed controller column). The flow rates are shown in the performance diagram. The planned use of a frequency inverter without a sine filter should be indicated when placing the order. This requires a change of fan version and additional costs, if necessary. Explosion-proof types are not controllable.

Electrical connection

Standard terminal box (protection category IP55) on outside of duct.

Installation

Installation possible in any position; but be aware of any condensate drain holes depending on usage.

Motor protection

All types (except for explosion-proof models and type VARD 400/4/2) are equipped with thermal contacts. These should be wired with the motor protection circuit breaker (see type table) for effective motor protection. Motors without thermal contacts must be protected by means of on-site a motor protection circuit breaker.

Noise levels

See sound power information above performance diagram. The lower sound pressure value can be determined using the diagram on the "Technical information" page. See page 14 f for noise emissions and room acoustics.

Reference Page

Techn. description	254
Selection table	255
Planning information	14 ff.

Special design

Different voltage, frequency, protection category, higher air flow temperature and acid protection upon request.

The technical information on p. 19 ff. must be observed.

Type	Ref. no.	Speed min ⁻¹	Flow rate free-blow. V m ³ /h	Power consump.* kW	Voltage V	Current consumption*		Wiring diagram No.	Max. air flow temp.		Weight net ca. kg	Dim. B Motor protru- sion mm	Speed controller 5-step Pole chang. switch		Motor pro- tection circuit breaker for connecting built-in thermal contacts		Vibration dampers		
						at rated voltage A	with control A		at rated voltage +°C	with control +°C			Type	Ref. no.	Type	No.	Compr. Type	Tens. Type	
Single-phase alternating current, 50 Hz, protection category IP54																			
VARW 400/4	06688	1375	5130	0.70	230	3.00	3.35	967	60	40	22.5	–	MWS 5 ¹⁾	01949	MW	01579	SDD 1	SDZ 1	
Three-phase current, 50 Hz, protection category IP54																			
VARD 400/4	06690	1400	5240	0.72	400	1.95	2.00	469	60	40	22.5	–	RDS 4 ^{1) 2)}	01316	MD	05849	SDD 1	SDZ 1	
Two-speed, three-phase current, 50 Hz, Y/Δ connection, protection category IP54																			
VARD 400/2/2	06691	2475/2800	8320/10610	3.63/4.95	400 Y/Δ	5.75/7.95	–	520	60	40	74.0	202	RDS 11 ³⁾	01332	M 4 ²⁾	01571	SDD 1	SDZ 2	
Pole-changeable, 2 speeds (Dahlander winding Y/Y), Three-phase current, 50 Hz, protection category IP54																			
VARD 400/4/2	06782	1400/2890	5220/10700	0.80/5.90	400	2.43/9.13	–	471	40	–	74.0	207	PDA 12 ³⁾	05081	–	–	SDD 1	SDZ 2	
Ex Explosion-proof, II 2G Ex h IIB T3 Gb, Motor Ex e, three-phase current 400 Volt, 50 Hz, protection category IP55																			
VARD 400/6 Ex	06692	920	3465	0.25	400	0.97	–	470	40	–	21.0	–	not permitted	not permitted	SDD 1	SDZ 1			
VARD 400/4 Ex	06693	1430	5360	0.55	400	1.51	–	470	40	–	25.0	–	not permitted	not permitted	SDD 1	SDZ 1			
VARD 400/2 Ex ⁴⁾	06694	2920	10950	4.60	400	9.10	–	498	40	–	83.0	255	not permitted	not permitted	SDD 2	SDZ 2			

* For Ex types: Motor ratings see information on page 20. ¹⁾ incl. motor protection circuit breaker. ²⁾ includes operating and speed switch. ³⁾ Flush-m. version see Switch product page.
⁴⁾ A vibration monitoring system (on-site) must be provided according to DIN EN 14986. ⁵⁾ Frequency inverter with integrated sine filter, Type FU-BS 2.5, No. 05459, see product page FU.

Performance curves VAR 400/2

n=2800 1/min

Frequency	Hz	Tot.	125	250	500	1k	2k	4k	8k
L _{WA}	Air noise	dB(A)	98	69	80	91	94	90	81
L _{PA, 4m}	Air noise	dB(A)	78	49	60	71	74	70	61

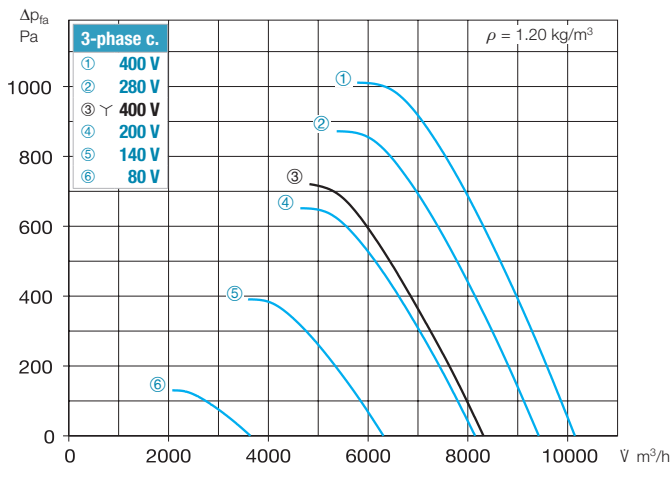

Performance curves VAR 400/4

n=1450 1/min

Frequency	Hz	Tot.	125	250	500	1k	2k	4k	8k
L _{WA}	Air noise	dB(A)	83	59	72	77	79	77	60
L _{PA, 4m}	Air noise	dB(A)	63	39	52	57	59	57	40

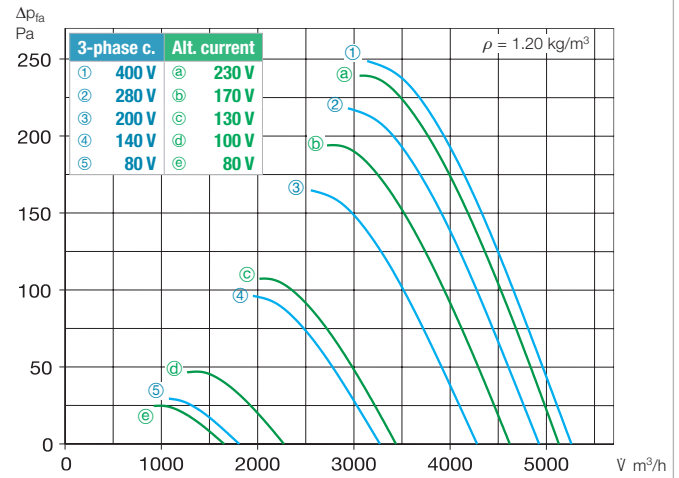

Performance curve VAR 400/6

n=930 1/min

Frequency	Hz	Tot.	125	250	500	1k	2k	4k	8k
L _{WA}	Air noise	dB(A)	72	56	62	68	64	56	47
L _{PA, 4m}	Air noise	dB(A)	52	36	42	48	44	36	27

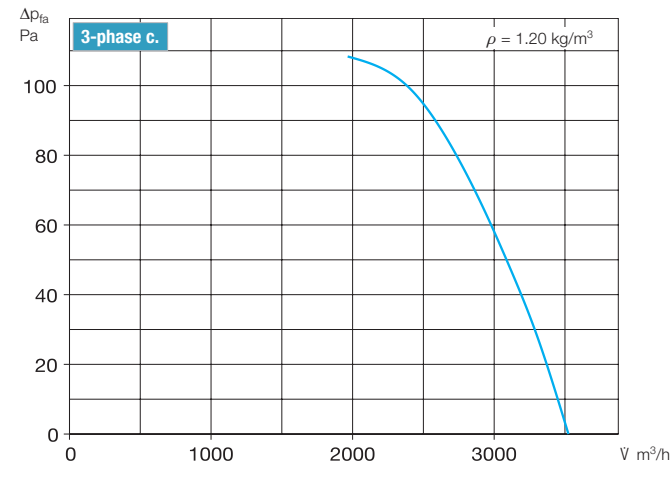

Other accessories Page

^{b)}Access. for expl.-proof fans

- Flanged flexible connector STS 400 Ex** Ref. no. 02505
- Flexible connecting sleeve FM 400 Ex** Ref. no. 01692

- Filters and silencers 481 ff.
- Shutters and ventilation grilles 561 ff.
- Speed controllers, controllers and switches 599 ff.

Accessories VAR 400 Description see page 276 ff.

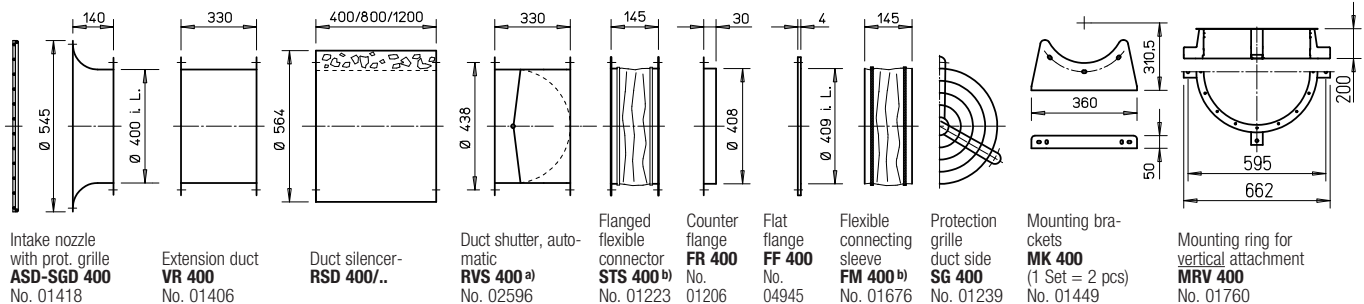

^{a)} Shutter, motorised see Accessories product pages. ^{b)} Types for explosion-proof fans see left page.

VAR 450



Also available in version:

Dimensions VAR 450

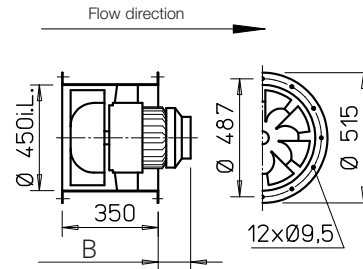

Dim. B see table
 Dim. in mm

■ Casing

Duct with double-sided flange DIN 24155 p. 3. Made of galvanised steel sheet, fixed guide wheel with inner hub for mounting the flange motor. Types with $n = 2800 \text{ min}^{-1}$ welded casing, hot-dip galvanised.

■ Impeller

Optimised for high pressure and volume performance. Special development with spatially curved blades made of hot-dip galvanised steel.

■ Drive

Directly through maintenance-free flange motor. Closed design type IP54. Aluminium or grey cast iron casing with cooling fins. Radio interference-free, sealed ball bearings. Tropicalised winding with moisture proof coating. With condensate drain holes upon request (except for explosion-proof types), and the installation method must be indicated when placing the order.

■ Power control

The voltage-controllable types are identified in the "Current consumption with control mode" column with a value which must be observed when determining the controller (see Speed controller column). The flow rates are shown in the performance diagram. The planned use of a frequency inverter without a sine filter should be indicated when placing the order. This requires a change of fan version and additional costs, if necessary. Explosion-proof types are not controllable.

■ Electrical connection

Standard terminal box (protection category IP55) on outside of duct.

■ Installation

Installation possible in any position; but be aware of any condensate drain holes depending on usage.

■ Motor protection

All types (except for explosion-proof models) are equipped with thermal contacts or PTC thermistors. These should be wired with the motor protection circuit breaker (see type table) for effective motor protection. Motors without thermal contacts must be protected by means of on-site a motor protection circuit breaker.

■ Noise levels

See sound power information above performance diagram. The lower sound pressure value can be determined using the diagram on the "Technical information" page. See page 14 f for noise emissions and room acoustics.

■ Reference Page

Techn. description	254
Selection table	255
Planning information	14 ff.

■ Special design

Different voltage, frequency, protection category, higher air flow temperature and acid protection upon request.

The technical information on p. 19 ff. must be observed.

Type	Ref. no.	Speed	Flow rate free-blow.	Power consump.*	Voltage	Current consumption*		Wiring diagram	Max. air flow temp.		Weight net	Dim. B Motor protrusion	Speed controller 5-step Pole chang. switch		Motor protection circuit breaker for connecting built-in thermal contacts		Vibration dampers		
						at rated voltage	with control		at rated voltage	with control			Type	Ref. no.	Type	No.	Compr.	Tens.	
min ⁻¹ V m ³ /h kW V A A No. +°C +°C ca. kg mm Type Ref. no. Type No. Type Type																			
Single-phase alternating current, 50 Hz, protection category IP54																			
VARW 450/4	06736	1330	7180	1.47	230	6.50	7.00	968	60	40	45.0	145	MWS 7.5 ¹⁾	01950	MW	01579	SDD 1	SDZ 1	
Three-phase current, 50 Hz, protection category IP54																			
VARD 450/2	06698	2950	14210	8.03	400	13.8	–	776	60	–	95.0	252	FU-CS 18 ¹⁾	05469	MSA ³⁾	01289	SDD 2	SDZ 2	
Two-speed, three-phase current, 50 Hz, γ/Δ connection, protection category IP54																			
VARD 450/4/4	06697	1100/1370	5930/7390	0.74/1.00	400 γ/Δ	1.2/2.3	2.3	520	60	40	45.0	145	RDS 4 ¹⁾	01316	M 4 ²⁾	01571	SDD 1	SDZ 1	
Ex Explosion-proof, II 2G Ex h IIB T3 Gb, Motor Ex e, three-phase current 400 Volt, 50 Hz, protection category IP55																			
VAR 450/6 Ex	06699	900	5020	0.25	400	0.99	–	470	40	–	48.0	97	not permitted	not permitted	not permitted	not permitted	SDD 1	SDZ 1	
VAR 450/4 Ex	06700	1450	7640	1.00	400	2.25	–	470	40	–	51.0	173	not permitted	not permitted	not permitted	not permitted	SDD 1	SDZ 1	
VAR 450/2 Ex ⁴⁾	06701	2930	15810	7.50	400	14.10	–	498	40	–	155.0	259	not permitted	not permitted	not permitted	not permitted	SDD 2	SDZ 2	

* For Ex types: Motor ratings see information on page 20. ¹⁾ incl. motor protection circuit breaker. ²⁾ includes operating and speed switch. ³⁾ for PTC thermistor temperature sensor.
⁴⁾ A vibration monitoring system (on-site) must be provided according to DIN EN 14986. ⁵⁾ with integrated sine filter, see product page FU.

Performance curve VAR 450/2

n=2800 1/min

Frequency	Hz	Tot.	125	250	500	1k	2k	4k	8k
L _{WA} Air noise		dB(A)	103	73	84	95	98	94	85
L _{PA, 4m} Air noise		dB(A)	83	53	64	75	78	74	65

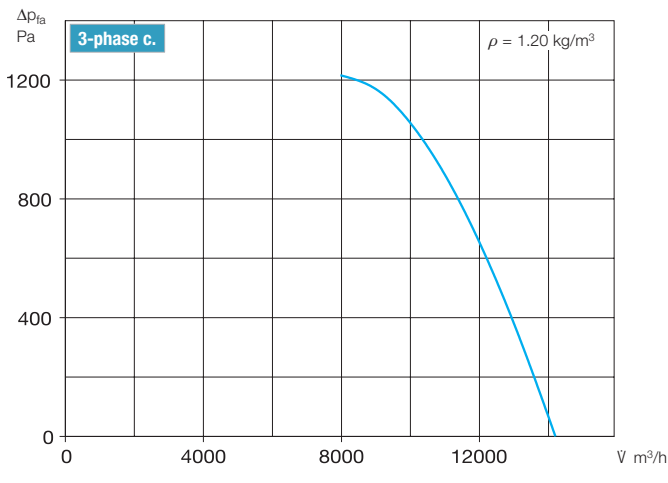

Performance curves VAR 450/4

n=1400 1/min

Frequency	Hz	Tot.	125	250	500	1k	2k	4k	8k
L _{WA} Air noise		dB(A)	87	62	76	81	83	80	74
L _{PA, 4m} Air noise		dB(A)	67	42	56	61	63	60	54

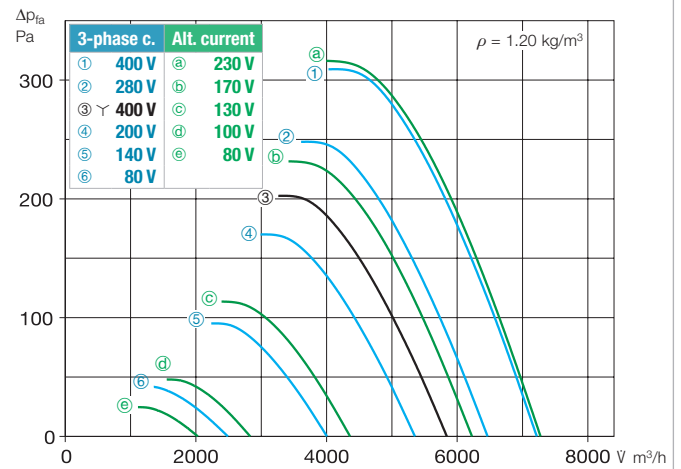

Performance curve VAR 450/6

n=930 1/min

Frequency	Hz	Tot.	125	250	500	1k	2k	4k	8k
L _{WA} Air noise		dB(A)	76	60	65	71	72	67	59
L _{PA, 4m} Air noise		dB(A)	56	40	45	51	52	47	39

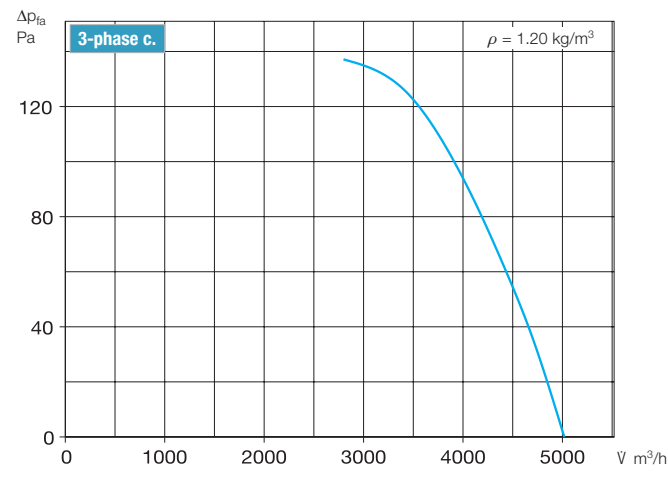

Other accessories Page

^{b)}Access. for expl.-proof fans

Flanged flexible connector
STS 450 Ex Ref. no. 02506

Flexible connecting sleeve
FM 450 Ex Ref. no. 01693

Filters and silencers 481 ff.

Shutters and ventilation grilles 561 ff.

Speed controllers, controllers and switches 599 ff.

Accessories VAR 450 Description see page 276 ff.

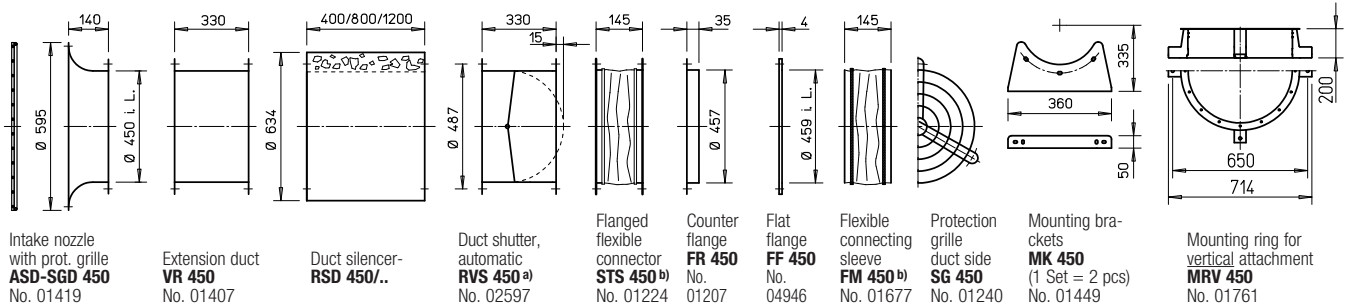

Intake nozzle with prot. grille
ASD-SGD 450
No. 01419

Extension duct
VR 450
No. 01407

Duct silencer
RSD 450/..

Duct shutter, automatic
RVS 450^{a)}
No. 02597

Flanged flexible connector
STS 450^{b)}
No. 01224

Counter flange
FR 450
No. 01207

Flat flange
FF 450
No. 04946

Flexible connecting sleeve
FM 450^{b)}
No. 01677

Protection grille duct side
SG 450
No. 01240

Mounting brackets
MK 450
(1 Set = 2 pcs)
No. 01449

Mounting ring for vertical attachment
MRV 450
No. 01761

^{a)} Shutter, motorised see Accessories product pages. ^{b)} Types for explosion-proof fans see left page.

VAR 500



Also available in version:

Dimensions VAR 500

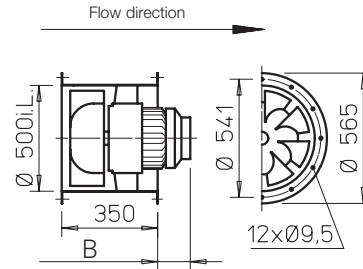

Dim. B see table
 Dim. in mm

Casing

Duct with double-sided flange DIN 24155 p. 3. Made of galvanised steel sheet, fixed guide wheel with inner hub for mounting the flange motor. Types with $n = 2800 \text{ min}^{-1}$ welded casing, hot-dip galvanised.

Impeller

Optimised for high pressure and volume performance. Special development with spatially curved blades made of hot-dip galvanised steel.

Drive

Directly through maintenance-free flange motor. Closed design type IP54. Aluminium or grey cast iron casing with cooling fins. Radio interference-free, sealed ball bearings. Tropicalised winding with moisture proof coating. With condensate drain holes upon request (except for explosion-proof types), and the installation method must be indicated when placing the order.

Power control

The voltage-controllable types are identified in the "Current consumption with control mode" column with a value which must be observed when determining the controller (see Speed controller column). The flow rates are shown in the performance diagram. The planned use of a frequency inverter without a sine filter should be indicated when placing the order. This requires a change of fan version and additional costs, if necessary. Explosion-proof types are not controllable.

Electrical connection

Standard terminal box (protection category IP55) on outside of duct.

Installation

Installation possible in any position; but be aware of any condensate drain holes depending on usage.

Motor protection

All types (except for explosion-proof models) are equipped with thermal contacts or PTC thermistors. These should be wired with the motor protection circuit breaker (see type table) for effective motor protection. Motors without thermal contacts must be protected by means of on-site a motor protection circuit breaker.

Noise levels

See sound power information above performance diagram. The lower sound pressure value can be determined using the diagram on the "Technical information" page. See page 14 f for noise emissions and room acoustics.

Reference	Page
Techn. description	254
Selection table	255
Planning information	14 ff.

Special design

Different voltage, frequency, protection category, higher air flow temperature and acid protection upon request.

The technical information on p. 19 ff. must be observed.

Type	Ref. no.	Speed min ⁻¹	Flow rate free-blow. V m ³ /h	Power consump.* kW	Voltage V	Current consumption*		Wiring diagram No.	Max. air flow temp.		Weight net ca. kg	Dim. B Motor protru- sion mm	Speed controller 5-step Pole chang. switch		Motor pro- tection circuit breaker for connecting built-in thermal contacts		Vibration dampers		
						at rated voltage A	with control A		at rated voltage +°C	with control +°C			Type	Ref. no.	Type	No.	Compr. Type	Tens. Type	
Single-phase alternating current, 50 Hz, protection category IP5																			
VAR 500/4	06739	1340	9920	2.02	230	9.10	9.10	968	60	40	70.0	181	MWS 10 ¹⁾	01946	MW	01579	SDD 2	SDZ 2	
Three-phase current, 50 Hz, protection category IP54																			
VAR 500/2	06705	2935	21730	15.70	400	29.00	–	776	40	–	180.0	367	FU-CS 32 ¹⁾ 05471	MSA ³⁾ 01289	SDD 2	SDZ 3			
Two-speed, three-phase current, 50 Hz, γ/Δ connection, protection category IP54																			
VAR 500/4/4	06704	1120/1370	8360/10070	1.2/1.8	400 γ/Δ	2.1/3.9	3.9	520	60	40	70.0	126	RDS 7 ¹⁾	01578	M 4 ²⁾	01571	SDD 2	SDZ 2	
Ex Explosion-proof, II 2G Ex h IIB T3 Gb, Motor Ex e, three-phase current 400 Volt, 50 Hz, protection category IP55												Pole chang. switch							
VAR 500/6 Ex	06706	945	6810	0.55	400	1.60	–	470	40	–	70.0	121	not permitted		not permitted		SDD 2	SDZ 2	
VAR 500/4 Ex	06707	1445	10470	2.00	400	4.20	–	470	40	–	75.0	235	not permitted		not permitted		SDD 2	SDZ 2	

* For Ex types: Motor ratings see information on page 20. ¹⁾ incl. motor protection circuit breaker. ²⁾ includes operating and speed switch. ³⁾ for PTC thermistor temperature sensor.
⁴⁾ A vibration monitoring system (on-site) must be provided according to DIN EN 14986. ⁵⁾ with integrated sine filter, see product page FU.

Performance curve VAR 500/2

n=2900 1/min

Frequency	Hz	Tot.	125	250	500	1k	2k	4k	8k
L _{WA}	Air noise	dB(A)	106	76	87	99	101	97	89
L _{PA, 4m}	Air noise	dB(A)	86	56	67	79	81	81	77

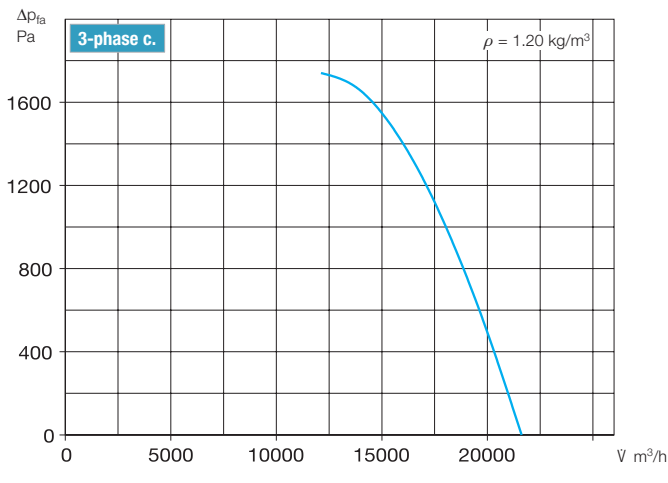

Performance curves VAR 500/4

n=1450 1/min

Frequency	Hz	Tot.	125	250	500	1k	2k	4k	8k
L _{WA}	Air noise	dB(A)	90	66	79	84	86	84	77
L _{PA, 4m}	Air noise	dB(A)	70	46	59	64	66	64	57

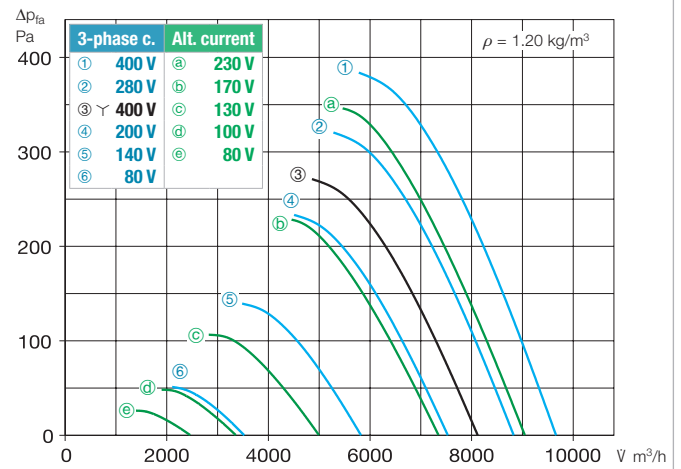

Performance curve VAR 500/6

n=930 1/min

Frequency	Hz	Tot.	125	250	500	1k	2k	4k	8k
L _{WA}	Air noise	dB(A)	79	63	69	74	75	71	63
L _{PA, 4m}	Air noise	dB(A)	59	43	49	54	55	51	43

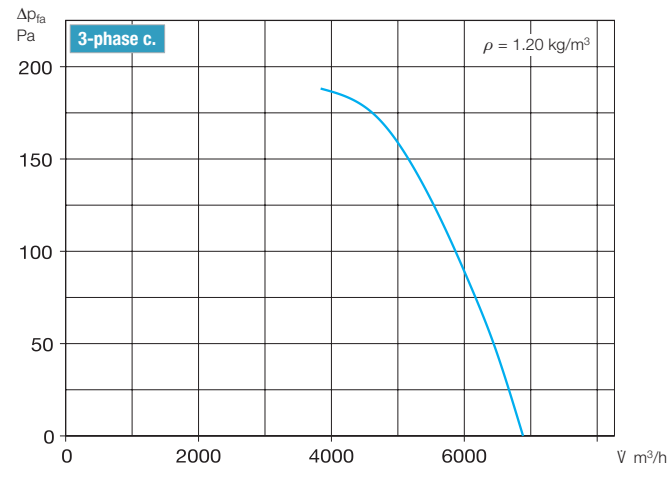

Other accessories Page

^{b)}Access. for expl.-proof fans

Flanged flexible connector	
STS 500 Ex	Ref. no. 02507
Flexible connecting sleeve	
FM 500 Ex	Ref. no. 01694

Filters and silencers	481 ff.
Shutters and ventilation grilles	561 ff.
Speed controllers, controllers and switches	599 ff.

Accessories VAR 500 Description see page 276 ff.

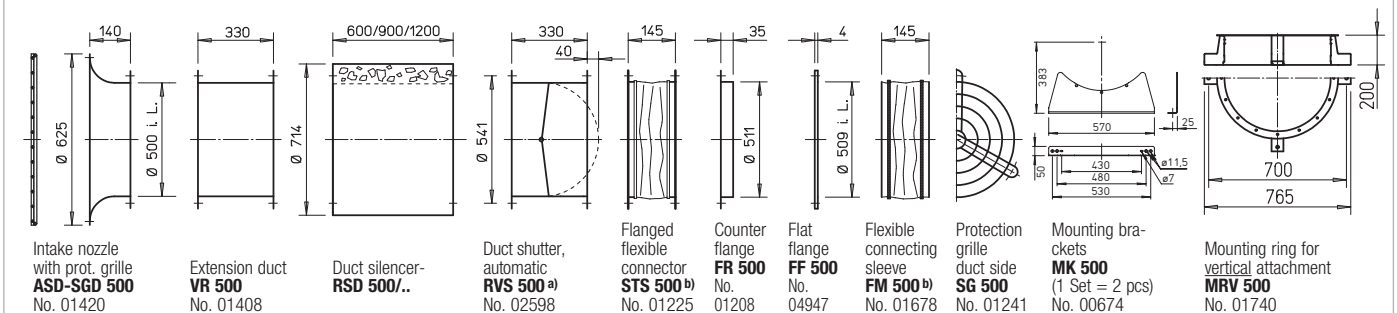

^{a)} Shutter, motorised see Accessories product pages. ^{b)} Types for explosion-proof fans see left page.

VAR 560



Also available in version:

Dimensions VAR 560

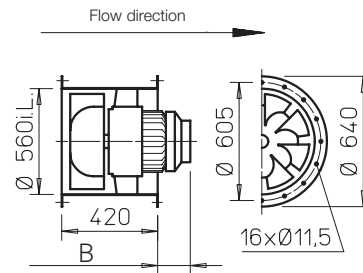

Dim. B see table
 Dim. in mm

■ Casing

Duct with double-sided flange DIN 24155 p. 3. Made of galvanised steel sheet, fixed guide wheel with inner hub for mounting the flange motor.

■ Impeller

Optimised for high pressure and volume performance. Special development with spatially curved blades made of hot-dip galvanised steel.

■ Drive

Directly through maintenance-free flange motor. Closed design type IP54. Aluminium or grey cast iron casing with cooling fins. Radio interference-free, sealed ball bearings. Tropicalised winding with moisture proof coating. With condensate drain holes upon request (except for explosion-proof types), and the installation method must be indicated when placing the order.

■ Power control

The voltage-controllable types are identified in the "Current consumption with control mode" column with a value which must be observed when determining the controller (see Speed controller column). The flow rates are shown in the performance diagram. Explosion-proof types are not controllable.

■ Electrical connection

Standard terminal box (protection category IP55) on outside of duct.

■ Installation

Installation possible in any position; but be aware of any condensate drain holes depending on usage.

■ Motor protection

All types (except for explosion-proof models) are equipped with thermal contacts. These should be wired with the motor protection circuit breaker (see type table) for effective motor protection. Motors without thermal contacts must be protected by means of on-site a motor protection circuit breaker.

■ Noise levels

See sound power information above performance diagram. The lower sound pressure value can be determined using the diagram on the "Technical information" page. See page 14 f for noise emissions and room acoustics.

Reference	Page
Techn. description	254
Selection table	255
Planning information	14 ff.

■ Special design

Different voltage, frequency, protection category, higher air flow temperature and acid protection upon request.

The technical information on p. 19 ff. must be observed.

Type	Ref. no.	Speed min ⁻¹	Flow rate free-blow. m ³ /h	Power consump.* kW	Voltage V	Current consumption*		Wiring diagram No.	Max. air flow temp.		Weight net ca. kg	Dim. B Motor protru- sion mm	Speed controller 5-step Pole chang. switch		Motor protection circuit breaker for connecting built-in thermal contacts		Vibration dampers	
						at rated voltage A	with control A		at rated voltage +°C	with control +°C			Type	Ref. no.	Type	No.	Compr. Type	Tens. Type
Two-speed, three-phase current, 50 Hz, Y/Δ connection, protection category IP54																		
VAR 560/4/4	06711	1130/1380	10780/12810	2.20/3.00	400Y/Δ	3.5/5.9	6.5	520	60	40	95.0	159	RDS 7 ¹⁾	01578	M 4 ²⁾	01571	SDD 2	SDZ 2
Pole-changeable, 2 speeds (Dahlander winding Y/Y), Three-phase current, 50 Hz, protection category IP54																		
VAR 560/8/4	06790	705/1440	6590/13570	0.90/3.60	400	2.9/8.3	—	471	60	—	100.0	175	PDA 12 ³⁾	05081	—	—	SDD 2	SDZ 2
Ex Explosion-proof, II 2G Ex h IIB T3 Gb, Motor Ex e, three-phase current 400 Volt, 50 Hz, protection category IP55																		
VAR 560/8 Ex	06712	700	7120	0.37	400	1.61	—	470	40	—	85.0	84	not permitted	not permitted	SDD 2	SDZ 2	SDD 2	SDZ 2
VAR 560/6 Ex	06713	950	9360	1.10	400	2.70	—	470	40	—	90.0	180	not permitted	not permitted	SDD 2	SDZ 2	SDD 2	SDZ 2
VAR 560/4 Ex ⁴⁾	06714	1440	14980	3.60	400	7.70	—	498	40	—	105.0	190	not permitted	not permitted	SDD 2	SDZ 2	SDD 2	SDZ 2

* For Ex types: Motor ratings see information on page 20. ¹⁾ incl. motor protection circuit breaker. ²⁾ includes operating and speed switch. ³⁾ Flush-m. version see Switch product page.

⁴⁾ A vibration monitoring system (on-site) must be provided according to DIN EN 14986.

Performance curves VAR 560/4

n=1450 1/min

Frequency	Hz	Tot.	125	250	500	1k	2k	4k	8k	
L _{WA} Air noise		dB(A)	93	69	83	87	90	87	80	70
L _{PA, 4m} Air noise		dB(A)	73	49	63	67	70	67	60	50

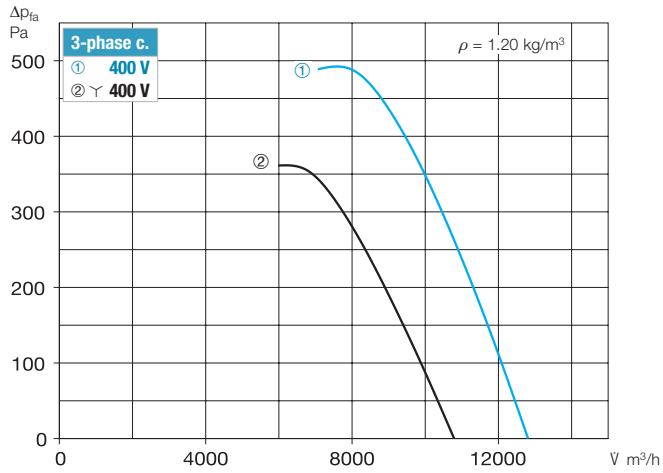

Performance curve VAR 560/6

n=950 1/min

Frequency	Hz	Tot.	125	250	500	1k	2k	4k	8k	
L _{WA} Air noise		dB(A)	83	67	72	78	79	75	67	58
L _{PA, 4m} Air noise		dB(A)	63	47	52	58	59	55	47	38

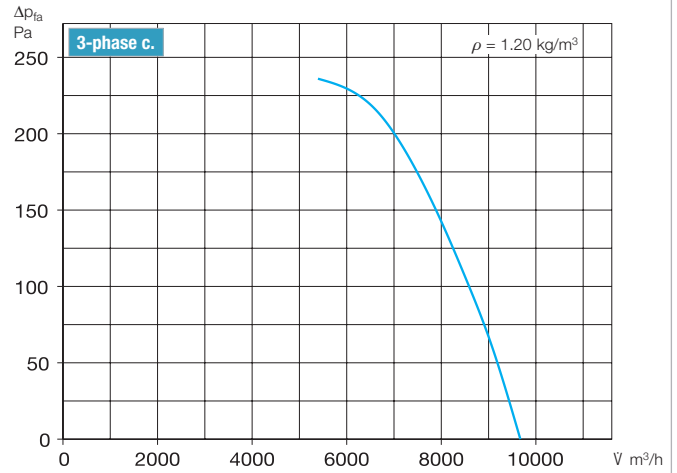

Performance curve VAR 560/8

n=725 1/min

Frequency	Hz	Tot.	125	250	500	1k	2k	4k	8k	
L _{WA} Air noise		dB(A)	76	61	68	72	72	66	58	51
L _{PA, 4m} Air noise		dB(A)	56	41	48	52	52	46	38	31

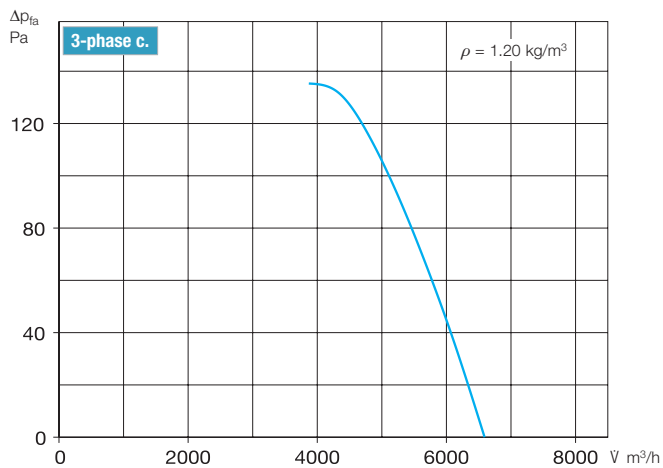

Other accessories Page

^{b)}Access. for expl.-proof fans

Flanged flexible connector
STS 560 Ex Ref. no. 02508

Flexible connecting sleeve
FM 560 Ex Ref. no. 02508

Filters and silencers 481 ff.

Shutters and ventilation grilles 561 ff.

Speed controllers, controllers and switches 599 ff.

Accessories VAR 560 Description see page 276 ff.

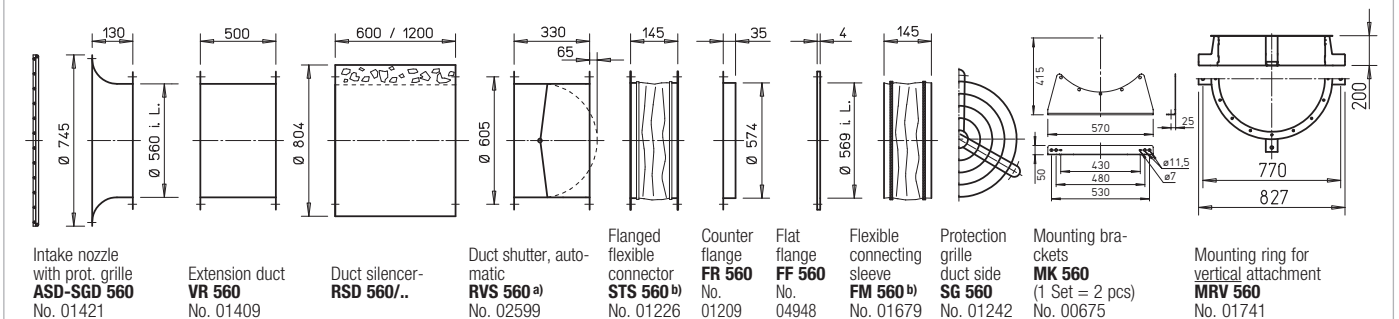

^{a)} Shutter, motorised see Accessories product pages. ^{b)} Types for explosion-proof fans see left page.

VAR 630



Also available in version:

Dimensions VAR 630

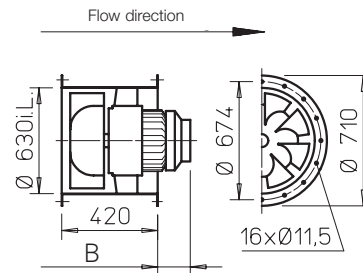

Dim. B see table
 Dim. in mm

■ Casing

Duct with double-sided flange DIN 24155 p. 3. welded construction, hot-dip galvanised. Welded-in guide wheel with inner hub for mounting the flange motor, hot-dip galvanised.

■ Impeller

Optimised for high pressure and volume performance. Special development with spatially curved blades made of hot-dip galvanised steel.

■ Drive

Directly through maintenance-free flange motor. Closed design type IP54. Aluminium or grey cast iron casing with cooling fins. Radio interference-free, sealed ball bearings. Tropicalised winding with moisture proof coating. With condensate drain holes upon request (except for explosion-proof types), and the installation method must be indicated when placing the order.

■ Power control

Continuously variable (0-100 %) through the use of a frequency inverter (except for pole-changeable models). The planned use of a frequency inverter without a sine filter should be indicated when placing the order. This requires a change of fan version and additional costs, if necessary. Explosion-proof types are not controllable.

■ Electrical connection

Standard terminal box (protection category IP55) on outside of duct.

■ Installation

Installation possible in any position; but be aware of any condensate drain holes depending on usage.

■ Motor protection

Type VARD 630/4 is equipped with PTC thermistors. These should be wired with the motor protection circuit breaker (see type table) for effective motor protection. Motors without thermal contacts must be protected by means of on-site a motor protection circuit breaker.

■ Noise levels

See sound power information above performance diagram. The lower sound pressure value can be determined using the diagram on the "Technical information" page. See page 14 f for noise emissions and room acoustics.

Reference	Page
Techn. description	254
Selection table	255
Planning information	14 ff.

Special design

Different voltage, frequency, protection category, higher air flow temperature and acid protection upon request.

The technical information on p. 19 ff. must be observed.

Type	Ref. no.	Speed	Flow rate free-blow.	Power consump.*	Voltage	Current consumption*		Wiring diagram	Max. air flow temp.		Weight net	Dim. B Motor protrusion	Speed controller 5-step Pole chang. switch		Motor protection circuit breaker for connecting built-in thermal contacts		Vibration dampers		
						at rated voltage	with control		at rated voltage	with control			Type	Ref. no.	Type	No.	Compr.	Tens.	
		min ⁻¹	V m ³ /h	kW	V	A	A	No.	+°C	+°C	ca. kg	mm			Type	No.	Type	Type	
Three-phase current, 50 Hz, protection category IP5																			
VARD 630/4	06717	1400	21320	6.20	400	12.0/6.9	–	776	60	–	145.0	230	FU-BS 16 ⁹ 05463	MSA ⁴ 01289	SDD 2		SDZ 2		
														Pole chang. switch					
VARD 630/8/4	06792	715/1430	10590/21170	1.40/5.50	400	5.0/12.0	–	471	60	–	145.0	255	PDA 12 ⁹ 05081	–	–	SDD 2		SDZ 2	
Ex Explosion-proof, II 2G Ex h IIB T3 Gb, Motor Ex e, three-phase current 400 Volt, 50 Hz, protection category IP55																			
VARD 630/8 Ex	06718	705	10220	0.95	400	2.75	–	470	40	–	110.0	148	not permitted	not permitted	SDD 2		SDZ 2		
VARD 630/6 Ex	06719	965	13990	1.90	400	5.1	–	470	40	–	130.0	210	not permitted	not permitted	SDD 2		SDZ 2		
VARD 630/4 Ex ³	06720	1460	21400	6.80	400	13.4	–	498	40	–	165.0	251	not permitted	not permitted	SDD 2		SDZ 3		

* For Ex types: Motor ratings see information on page 20.

¹⁾ incl. motor protection circuit breaker and sine filter.

²⁾ includes operating and speed switch.

³⁾ Flush-m. version see Switch product page. ⁴⁾ for PTC thermistor temperature sensor.

⁵⁾ A vibration monitoring system (on-site) must be provided according to DIN EN 14986.

Performance curve VAR 630/4

n=1450 1/min

Frequency	Hz	Tot.	125	250	500	1k	2k	4k	8k
L _{WA} Air noise		dB(A)	97	73	89	91	93	84	74
L _{PA, 4m} Air noise		dB(A)	77	53	69	71	71	64	54

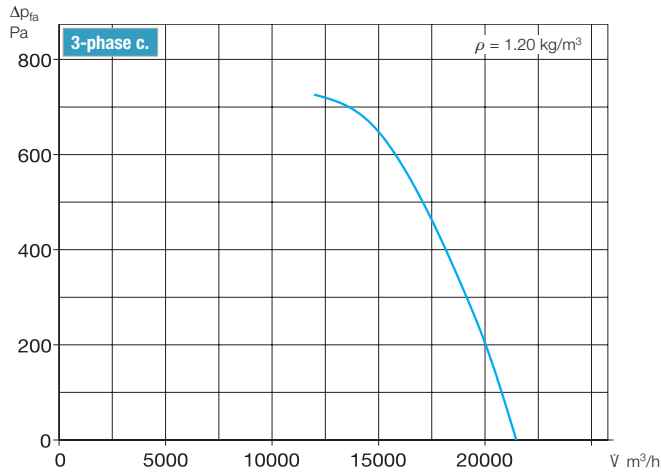

Performance curve VAR 630/6

n=1450 1/min

Frequency	Hz	Tot.	125	250	500	1k	2k	4k	8k
L _{WA} Air noise		dB(A)	87	70	76	82	83	78	62
L _{PA, 4m} Air noise		dB(A)	67	50	56	62	63	58	42

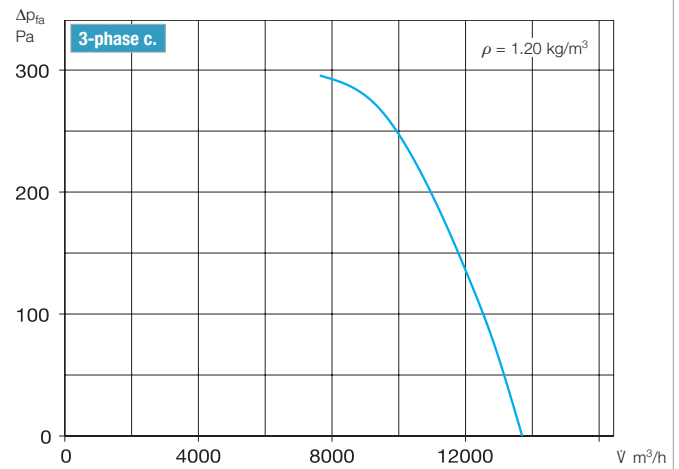

Performance curve VAR 630/8

n=725 1/min

Frequency	Hz	Tot.	125	250	500	1k	2k	4k	8k
L _{WA} Air noise		dB(A)	80	65	71	76	75	62	55
L _{PA, 4m} Air noise		dB(A)	60	45	51	56	55	42	35

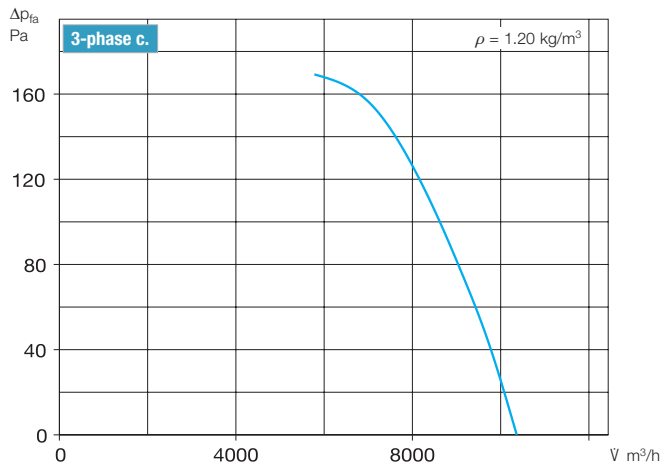

Other accessories Page

^{b)}Access. for expl.-proof fans

Flanged flexible connector
STS 630 Ex Ref. no. 02509

Flexible connecting sleeve
FM 630 Ex Ref. no. 01696

Filters and silencers 481 ff.

Shutters and ventilation grilles 561 ff.

Speed controllers, controllers and switches 599 ff.

Accessories VAR 630 Description see page 276 ff.

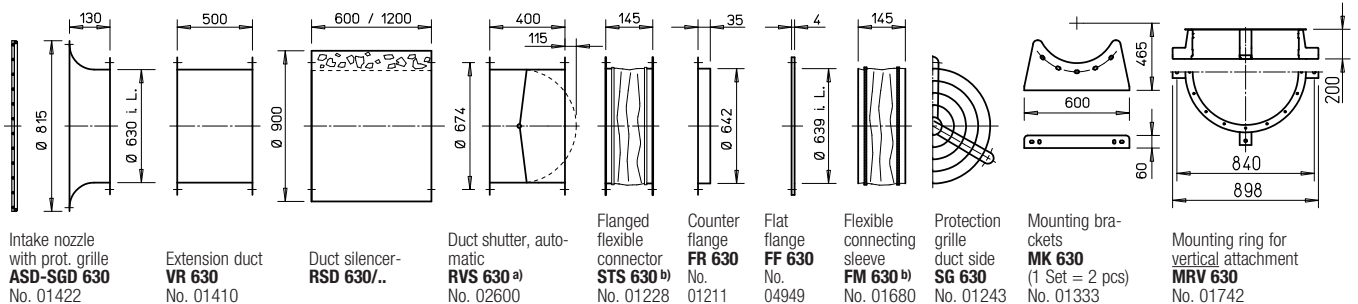

^{a)} Shutter, motorised see Accessories product pages. ^{b)} Types for explosion-proof fans see left page.

Smooth installation guaranteed – like clockwork.

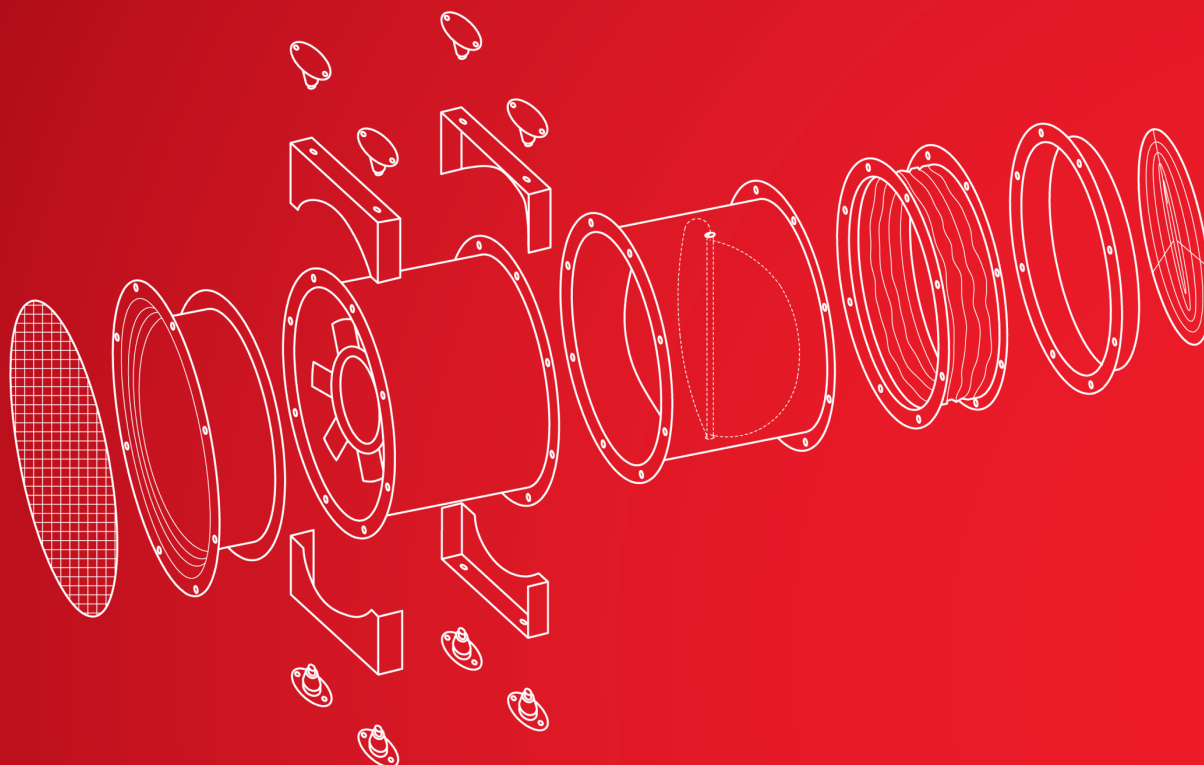

■ **Installation accessories circular duct fans**

Whatever the installation and duct connection requirements: Helios' wide range includes the right system components. From the intake nozzle to the electric duct shutter and vibration dampers.

277ff

■ **Silencers, air filters, heating elements**

Helios air treatment components provide for clean, warm and calm air. The extensive range includes all sizes and capacities, perfectly tailored to Helios fans. This provides the necessary flexibility for planning and installation.

481ff

■ **Shutters, ventilation grilles**

Weather-proof and corrosion-free. Made of break-resistant, UV-resistant plastic with a long service life. Helios shutters and weather protection grilles stand out due to their appealing design, robustness and ease of installation.

561ff

■ **Speed controllers, frequency inverters, controllers, switches**

In addition to the specific installation accessories for round duct fans, Helios offers a wide range of control and switching devices which are perfectly tailored to round duct fans.

599ff

ASD-SGD

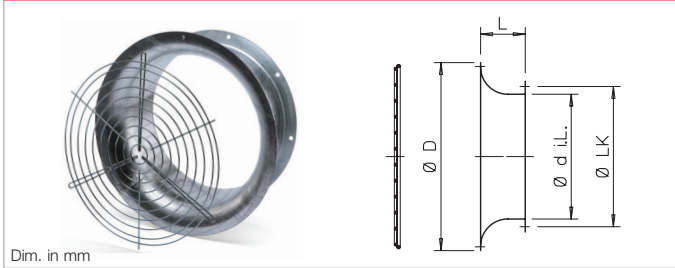

■ **Intake nozzle with protection grille** and large entry radius. Made sheet. With flange on connection side in accordance with DIN 24155, p. 2. Powder-coated protection

grille for inlet side coverage (galvanised from Ø 800) in accordance with DIN EN ISO 13857.

Type	Ref. no.	Ø D	L	Ø D i.L.	Ø LK	Weight aprx. kg
ASD 200*	01388	310	140	203	235	0.9
ASD-SGD 225	01413	345	140	225	259	2.5
ASD-SGD 250	01414	370	140	250	286	2.8
ASD-SGD 280	01415	400	140	280	322	3.2
ASD-SGD 315	01416	435	140	315	356	3.5
ASD-SGD 355	01417	475	140	355	395	4.0
ASD-SGD 400	01418	545	140	400	438	4.5
ASD-SGD 450	01419	595	140	450	487	5.7
ASD-SGD 500	01420	625	140	500	541	6.3
ASD-SGD 560	01421	745	130	560	605	7.0
ASD-SGD 630	01422	815	130	630	674	7.6
ASD-SGD 710	01423	955	200	710	751	19.5
ASD-SGD 800	01424	1060	200	800	837	22.3
ASD-SGD 900	01309	1140	200	900	934	25.0
ASD-SGD 1000	01310	1240	200	1000	1043	28.5

* without protection grille.

SG

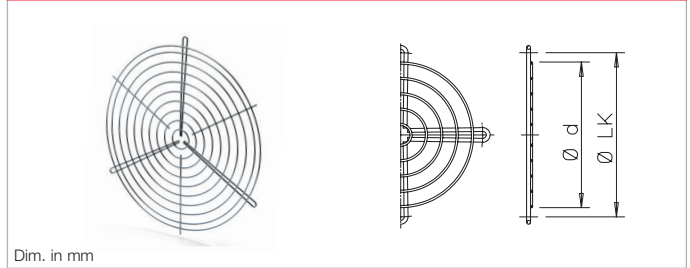

■ **Protection grille** for outlet side coverage. Powder-coated, colour: silver metallic (galvanised from Ø 800).

Dimensions and mounting clips tailored to fan/flange pipe nominal size in accordance with DIN 24155, p. 2. DIN EN ISO 13857.

Type	Ref. no.	Ø D	Ø LK	Weight aprx. kg	Number of attachment points
SG 200	01216	190	235	0.1	3
SG 225	01215	224	259	0.2	3
SG 250	01236	241	286	0.2	3
SG 280	01428	270	322	0.3	4
SG 315	01237	310	356	0.4	4
SG 355	01238	350	395	0.4	4
SG 400	01239	390	438	0.5	3
SG 450	01240	450	487	0.6	3
SG 500	01241	490	541	0.7	3
SG 560	01242	550	605	0.9	4
SG 630	01243	630	674	1.5	4
SG 710	01244	710	751	1.8	4
SG 800	01245	790	837	2.2	4
SG 900	01246	890	934	2.7	4
SG 1000	01290	990	1043	3.5	4

RVS

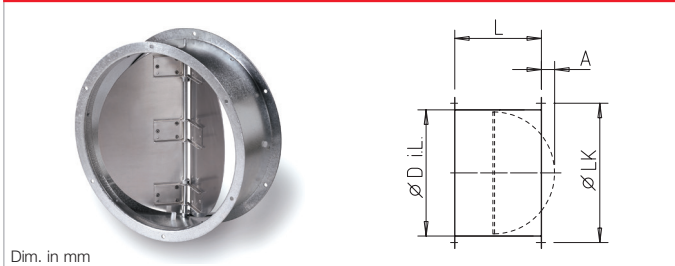

■ **Automatic duct shutter with spring return¹⁾**
Can be installed horizontally in any direction, vertically with through-flow from bottom to top. Shutter opening in flow direction; automatic function through fan operation. Spring mechanism outside of air

flow. Locking force depends on fan power and installation position can be changed. Shutter and casing made of galvanised steel sheet, shutter made of aluminium for nominal size 225 – 560 mm. Double-sided flange. Holes pursuant to DIN 24155, p. 2.

Type ²⁾	Ref. no.	Ø D i.L.	L	A	Ø LK	Weight aprx. kg
RVS 225	02591	225	300	—	259	3.0
RVS 250	02592	250	300	—	286	3.4
RVS 280	02593	280	300	—	322	3.9
RVS 315	02594	315	300	—	356	4.3
RVS 355	02595	355	300	—	395	5.0
RVS 400	02596	400	330	—	438	7.2
RVS 450	02597	454	330	15	487	10.4
RVS 500	02598	504	330	40	541	11.7
RVS 560	02599	560	330	65	605	16.1
RVS 630	02600	630	400	115	674	19.5
RVS 710	02601	710	400	155	751	26.5
RVS 800	02602	800	420	200	837	37.3
RVS 900	02603	900	420	250	934	41.8
RVS 1000	02604	1000	420	300	1043	47.3

¹⁾ Pressure loss diagram see page 564. ²⁾ Ambient temperature –30 to +100 °C.

RVM

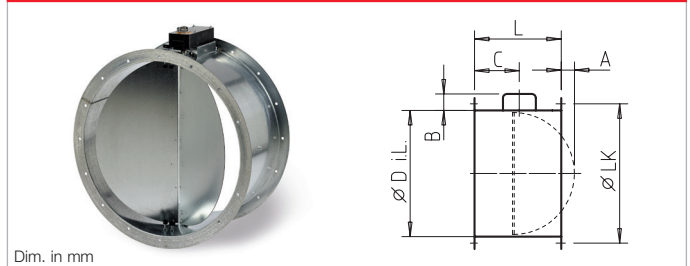

■ **Motorised duct shutter¹⁾**
like RVS, but can be installed horizontally and vertically in any direction and with a mounted spring return motor (outside of air flow). Elec. control parallel with fan; cable length 0.9 m, normally closed.

Ambient temperature –30 to +60 °C
Protection category IP54
Voltage/Frequency 230 V AC, 50/60 Hz
Power consumption – up to Ø 560 / from Ø 630 14 W/6.5 W
Shutter opening time, approx. 75 sec.
Wiring diagram no. 380.1

Type ³⁾	Ref. no.	Ø D i.L.	B	C	L	A	Ø LK	Weight aprx. kg
RVM 225	02575	225	95	130	300	—	259	3.3
RVM 250	02576	250	95	130	300	—	286	3.7
RVM 280	02577	280	95	130	300	—	322	4.2
RVM 315	02578	315	95	130	300	—	356	4.6
RVM 355	02579	355	95	130	300	—	395	5.3
RVM 400	02580	400	95	130	330	—	438	7.5
RVM 450	02581	454	95	130	330	15	487	10.7
RVM 500	02582	504	95	130	330	40	541	12.0
RVM 560	02583	560	95	130	330	65	605	16.4
RVM 630	02609	630	150	225	400	115	674	21.0
RVM 710	02610	710	150	225	400	155	751	28.0
RVM 800	02614	800	150	225	420	200	837	37.8
RVM 900	02615	900	150	225	420	250	934	42.3
RVM 1000*	02616	1000	150	225	420	300	1043	47.8

³⁾ Types RVM not for use in potentially explosive areas. *RVM 1000 only for horizontal throughflow.

VR

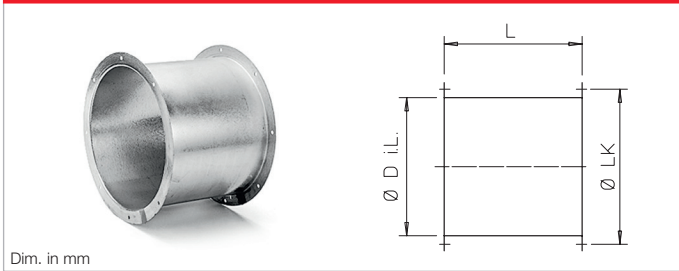

Extension duct

Pipe section with double-sided flanges and holes according to DIN 24155, p. 2. Made of hot-dip galvanised steel sheet for the

extension of the fan shaft. For types with protruding motor, for installation in pipeline. Prevents power losses in case of free outlet.

Type	Ref. no.	Ø D i.L.	L	Ø LK	Weight aprx. kg
VR 225	01401	225	300	259	2.5
VR 250	01402	250	300	286	2.8
VR 280	01403	280	300	322	3.2
VR 315	01404	315	300	356	3.5
VR 355	01405	355	300	395	4.0
VR 400	01406	400	330	438	6.0
VR 450	01407	454	330	487	9.0
VR 500	01408	504	330	541	10.0
VR 560	01409	560	500	605	14.0
VR 630	01410	630	500	674	15.5
VR 710	01411	710	500	751	21.5
VR 800	01412	800	420	837	31.0
VR 900	01311	900	420	934	34.0
VR 1000	01312	1000	420	1043	37.6

STS

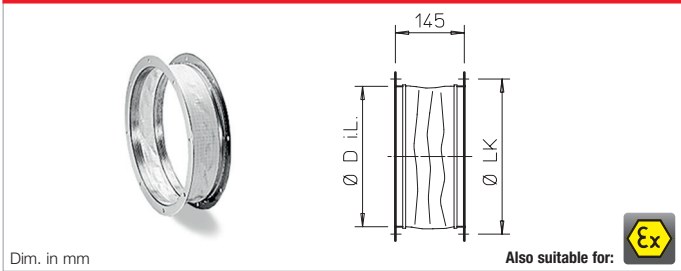

Flanged flexible connector

Flexible connector for installation between the fan and duct system. Prevents structure-borne noise transmission, bridges installation

tolerances. Elastic sleeve made of silicone-free PVC fabric (max. + 80 °C). With galvanised angle flange rings on both sides, dimensions according to DIN 24155 p. 2.

Type	Ref. no.	Ex Type*	Ref. no.	Ø D i.L.	Ø LK	Weight aprx. kg
STS 200	01219	—	—	205	235	1.3
STS 225	01218	STS 225 Ex	02500	229	259	1.1
STS 250	01220	STS 250 Ex	02501	252	286	1.3
STS 280	01231	STS 280 Ex	02502	288	322	1.5
STS 315	01221	STS 315 Ex	02503	322	356	1.8
STS 355	01222	STS 355 Ex	02504	361	395	2.3
STS 400	01223	STS 400 Ex	02505	404	438	2.5
STS 450	01224	STS 450 Ex	02506	453	487	3.8
STS 500	01225	STS 500 Ex	02507	507	541	3.4
STS 560	01226	STS 560 Ex	02508	570	605	4.5
STS 630	01228	STS 630 Ex	02509	638	674	4.6
STS 710	01229	STS 710 Ex	02510	711	751	7.0
STS 800	01233	STS 800 Ex	02511	801	837	7.5
STS 900	01234	STS 900 Ex	02512	898	934	7.5
STS 1000	01235	STS 1000 Ex	02513	1004	1043	15.0

* for explosion-proof fans.

FR / FF

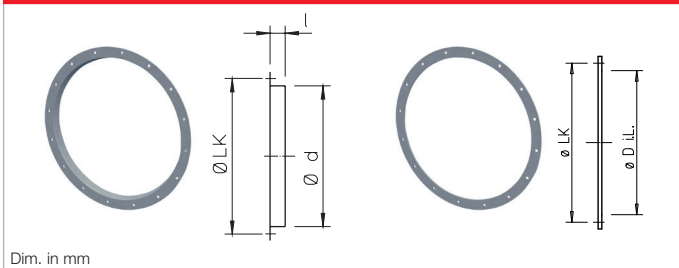

**Counter flange FR/
Flat flange FF**

Angle flange ring/flat flange ring made of galvanised steel sheet. Dimensions/holes according to DIN 24155 p. 2.

Type	Ref. no.	Type	Ref. no.	Ø LK	l	Ø D	Ø D i.L.	Weight aprx. kg
FR 200	01202	—	—	235	25	209	—	0.5
FR 225	01201	—	—	259	30	233	—	0.5
FR 250	01203	FF 250	04941	286	25	256	256	0.7
FR 280	01214	FF 280	04942	322	30	292	286	0.9
FR 315	01204	FF 315	04943	356	30	326	321	1.0
FR 355	01205	FF 355	04944	395	30	365	361	1.1
FR 400	01206	FF 400	04945	438	30	408	409	1.2
FR 450	01207	FF 450	04946	487	35	457	459	1.3
FR 500	01208	FF 500	04947	541	35	511	509	1.5
FR 560	01209	FF 560	04948	605	35	574	569	2.1
FR 630	01211	FF 630	04949	674	35	642	639	2.3
FR 710	01212	FF 710	04950	751	35	715	719	3.1
FR 800	01198	FF 800	04951	837	35	806	809	3.9
FR 900	01199	FF 900	04952	934	35	903	909	4.4
FR 1000	01210	FF 1000	04953	1043	35	1012	1009	9.5

FM

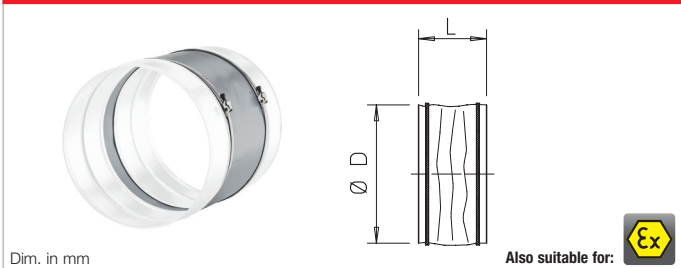

Flexible connecting sleeve

incl. 2 hose clamps. Installation between fan and duct system. Prevents structure-borne noise transmission, bridges installation

tolerances. Elastic sleeve made of silicone-free PVC fabric (max. temp. + 80 °C). UV- and weather resistant. Dimensions according to DIN 24155, p. 2.

Type	Ref. no.	Ex Type*	Ref. no.	Ø D	Ø L	Weight aprx. kg
FM 200	01670	FM 200 Ex	01686	213	145	0.2
FM 225	01671	FM 225 Ex	01687	235	145	0.2
FM 250	01672	FM 250 Ex	01688	260	145	0.2
FM 280	01673	FM 280 Ex	01689	296	145	0.2
FM 315	01674	FM 315 Ex	01690	330	145	0.2
FM 355	01675	FM 355 Ex	01691	369	145	0.3
FM 400	01676	FM 400 Ex	01692	412	145	0.3
FM 450	01677	FM 450 Ex	01693	461	145	0.3
FM 500	01678	FM 500 Ex	01694	515	145	0.4
FM 560	01679	FM 560 Ex	01695	577	145	0.4
FM 630	01680	FM 630 Ex	01696	646	145	0.4
FM 710	01666	—	—	720	145	0.5

* for explosion-proof fans.

MK

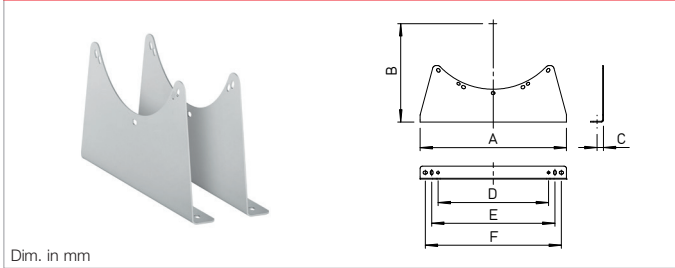

Dim. in mm

■ Mounting bracket

For attaching the fan flange casing to ceilings, walls or floors. Made of hot-dip galvanised steel. Hole matches the hole circle of the fan flange. Delivered as pair including screws and nuts.

■ Reference

In case of heavy motors, an extension duct VR (accessories) should be provided to place the centre of gravity. Attach the brackets to both external flanges.

Type	Ref. no.	A	B	C	D	E	F	Weight aprx. kg
MK 200-225	01446	310	208/220	20	—	220	265	1.5
MK 250-280	01447	340	227/245	20	—	240	285	1.7
MK 315-355	01448	380	281/300	25	250	295	340	2.2
MK 400-450	01449	360	311/335	25	240	280	320	2.6
MK 500	00674	570	383	25	430	480	530	5.3
MK 560	00675	570	415	25	430	480	530	5.3
MK 630	01333	600	465	30	460	510	560	8.5
MK 710	01372	670	515	35	515	565	620	10.5
MK 800	01373	680	565	35	500	550	—	15.5
MK 900	01374	760	625	35	580	630	—	18.0
MK 1000	01375	840	690	35	710	—	—	19.5

SDD-U

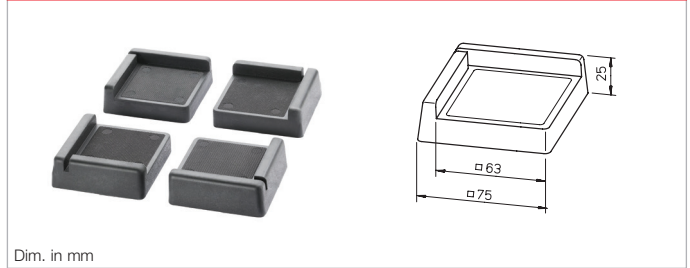

Dim. in mm

■ Vibration damper mounts

The elastic rubber elements SDD-U are suitable as mounts for the free-standing indoor installation of ventilation units on flat, horizontal surfaces. They prevent the direct transmission of vibrations and structure-borne noise to other

parts of buildings.

A set consists of four elements which are placed under the corners of the ventilation unit. Maximum pressure load: 40 kg/element = total 160 kg.

SDD-U Ref. no. 05627

SDD

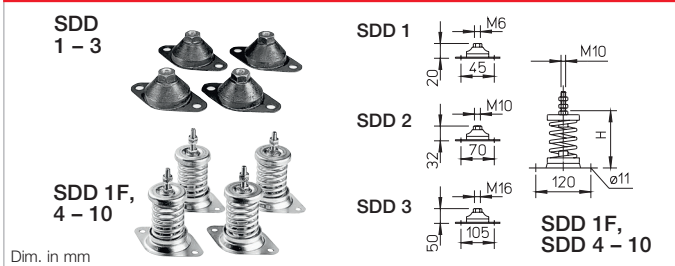

Dim. in mm

■ Vibration dampers for compression load

For vibration and noise-insulating installation of fans on horizontal surfaces. Easy installation in combination with MK (accessories). Selection according to fan weight, see table.

Rubber bonded metal elements must be used for small and medium weight loads and temperatures up to max. +60 °C, and spring-type vibration dampers must be used for high loads and temperatures above +60 °C (e.g. smoke extraction).

Type	Ref. no.	Max. fan weight kg	H Height in mm	Spring-type vibration damper	Delivery unit 1 set = 4 pcs
SDD 1	01452	80	*		
SDD 1 F	01942	80	112 – 87	•	
SDD 2	01453	180	*		
SDD 3	01367	750	*		
SDD 4	01944	130	112 – 87	•	
SDD 5	01924	210	112 – 86	•	
SDD 6	01926	350	112 – 85	•	
SDD 7	01928	520	112 – 85	•	
SDD 8	01930	900	112 – 82	•	
SDD 9	01934	1300	112 – 85	•	
SDD 10	01951	1800	112 – 88	•	

* specified in dimensional drawing.

SDZ

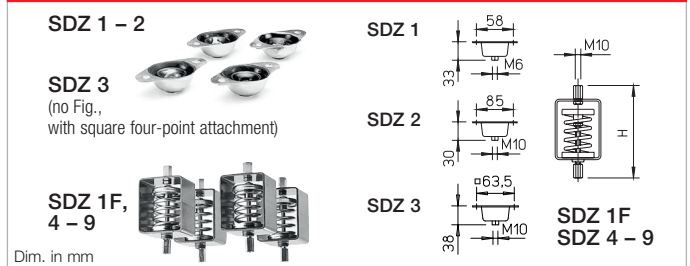

Dim. in mm

■ Vibration dampers for tensile load

For vibration and noise-insulating fan suspension (ceiling mounting). Design, description and delivery according to SDD series.

■ Important installation note for vibration dampers:

A uniform load distribution (balance centre of gravity in case of heavy motor) must be ensured during installation.

Type	Ref. no.	Max. fan weight kg	H Height in mm	Spring-type vibration damper	Delivery unit 1 set = 4 pcs
SDZ 1	01454	60	*		
SDZ 1 F	01943	80	190 – 215	•	
SDZ 2	01455	160	*		
SDZ 3	01366	300	*		
SDZ 4	01945	130	190 – 215	•	
SDZ 5	01925	210	190 – 216	•	
SDZ 6	01927	350	190 – 217	•	
SDZ 7	01929	520	190 – 217	•	
SDZ 8	01931	900	190 – 220	•	
SDZ 9	01935	1300	190 – 217	•	

* specified in dimensional drawing.

DIF

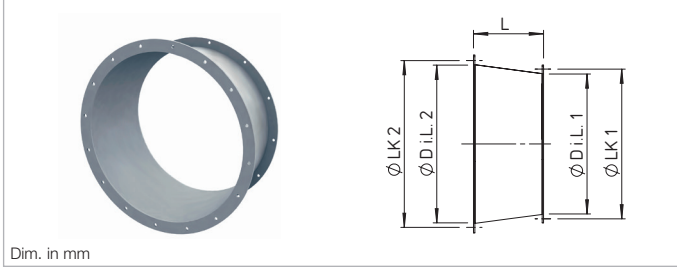

Dim. in mm

■ **Diffusor DIF**

Aerodynamically optimised diffusor for high pressure recovery. Delays air flow due to size step to convert dynamic pressure to static pressure. Additional application as an adapter for an optimised transition to the next size. Specially developed for application directly behind a fan and at the end of a pipeline as an outdoor outlet with reduced

outlet losses. In case of a free outlet at the diffusor, the protection grille (type SG) can be used in the next larger dimension. High-quality design made of hot-dip galvanised steel sheet with double-sided welded flange, hole pattern according to DIN 24155.

Type	Ref. no.	Size step	L	Ø D.i.L. 1	Ø LK 1	Ø D.i.L. 2	Ø LK 2	Weight aprx. kg
DIF 250	40230	250 to 400	200	250	286	400	438	5.5
DIF 280	03551	280 to 315	140	280	322	315	356	4.1
DIF 315	03552	315 to 355	160	315	356	355	395	4.9
DIF 355	03553	355 to 400	180	355	395	400	438	5.9
DIF 400	03554	400 to 450	200	400	438	450	487	7.0
DIF 450	03555	450 to 500	225	450	487	500	541	8.4
DIF 500	03556	500 to 560	250	500	541	560	605	11.5
DIF 560	03565	560 to 630	280	560	605	630	674	15.4
DIF 630	03566	630 to 710	315	630	674	710	751	19.0
DIF 710	03567	710 to 800	355	710	751	800	837	24.1
DIF 800	03568	800 to 900	400	800	837	900	934	37.8
DIF 900	03569	900 to 1000	450	900	934	1000	1043	45.7
DIF 1000	03570	1000 to 1120	500	1000	1043	1120	1174	54.9
DIF 1120	03571	1120 to 1250	560	1120	1174	1250	1311	66.5
DIF 1250	03572	1250 to 1400	630	1250	1311	1400	1465	81.3

MRV

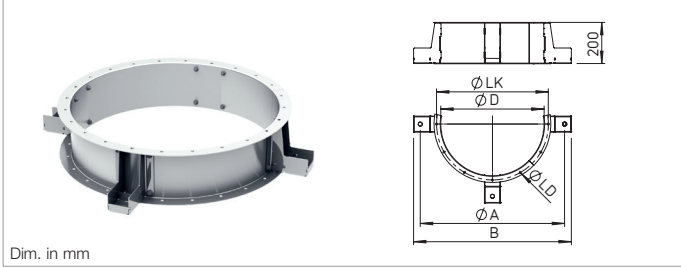

Dim. in mm

■ **Mounting ring MRV**

The mounting ring MRV is intended for the vertical attachment of fans (e.g. Helios types AVD, AMD, VAR etc.). Four mounting brackets for direct attachment or mounting vibration dampers (SDZ or SDD) ensure the secure vertical installation of fans. Made of hot-dip galvanised steel sheet.

Type	Ref. no.	Ø A	B	Ø D	Ø LK	Ø LD	Weight aprx. kg	Load capacity kg
MRV 315	01755	510	576	315	356	9.5 (8x)	6.5	280
MRV 355	01759	550	618	355	395	9.5 (8x)	6.9	280
MRV 400	01760	595	662	400	438	9.5 (12x)	7.4	280
MRV 450	01761	650	714	450	487	9.5 (12x)	7.9	280
MRV 500	01740	700	765	500	541	9.5 (12x)	8.3	280
MRV 560	01741	770	827	560	605	11.5 (16x)	12.9	390
MRV 630	01742	840	898	630	674	11.5 (16x)	13.9	390
MRV 710	01743	920	980	710	751	11.5 (16x)	15.7	390
MRV 800	01744	1030	1101	800	837	11.5 (24x)	24.8	1050
MRV 900	01745	1130	1201	900	934	11.5 (24x)	27.0	1050
MRV 1000	01749	1230	1301	1000	1043	11.5 (24x)	29.1	1050