

Revision	Date	Person	Change

		Target Client name Address		ADJUSTMENT AND CONTROL DEVICE LIST MyVallox 51K CFI			
		Drawer Person	Designer Person	Project number 001	Date Date	Revision A	Drawing number 001

PART ID	DEVICE	LOCATION	SETTING VALUE	BUYS / INSTALLS	NOTE.
%RHCO2	Concentration measurement	Internal	%RH- ja CO2-sensor	Standard delivery	Standard delivery
AI	Analog input	Connection box		Standard delivery	
DI1	Digital Input	Connection box		Standard delivery	
DI2	Digital Input	Connection box		Standard delivery	
F1	ICO Coarse >75%	Internal	ISO Coarse >75%	Standard delivery	
F2	ISO ePM1 >50%	Internal	ISO ePM1 >50%	Standard delivery	
F3	ICO Coarse >75%	Internal	ISO Coarse >75%	Standard delivery	
FG	Bypass damper motor	Internal		Standard delivery	
H1	Control Panel	Connection box		Standard delivery	Need to be wired. Can be more than one panel.
HRC	Cross counterflow heat exchanger	Internal		Standard delivery	
LAN	LAN/Ethernet-connection	Cable		Standard delivery	LAN-cabel on top of the unit.
LP	Electrical heater	Internal	900 W, with built-in thermal protection	Standard delivery	
MB	Modbus-connection	Connection box		Standard delivery	Connected to MV-unit connection box
PF, CF	EC Constant Flow -fan with airflow adjustment	Internal	EC Constant Flow -fan	Standard delivery	
TE1	NTC 4k7	Internal	4k7	Standard delivery	
TE2	NTC 4k7	Internal	4k7	Standard delivery	
TE3	NTC 4k7	Internal	4k7	Standard delivery	
TE4	NTC 4k7	Internal	4k7	Standard delivery	
TE5	NTC 4k7	Internal	4k7	Standard delivery	
TF, CF	EC Constant Flow -fan	Internal	EC Constant Flow -fan with airflow adjustment	Standard delivery	
X1	Relay output	Internal		Standard delivery	
CO2	CO2	Room		VC / EC	Option. External sensor connected to Modbus.
KNX	KNX-converter	External converter		VC / EC	Option, external KNX converter
RH	%RH	Room		VC / EC	Option. External sensor connected to Modbus.
TE6	External NTC-sensor	Duct	NTC 4k7	VC / EC	Option

Revision	Date	Person	Change



Target  
Client name  
Address

ADJUSTMENT AND CONTROL  
DEVICE LIST  
MyVallox 51K CFI

Drawer Person	Designer Person	Project number 001	Date. Date	Revision ...	Drawing number 001	Page 03 / 11
------------------	--------------------	-----------------------	---------------	-----------------	-----------------------	-----------------



## EXTERNAL ELECTRICAL CONNECTION

### MyVallox 51K CFI

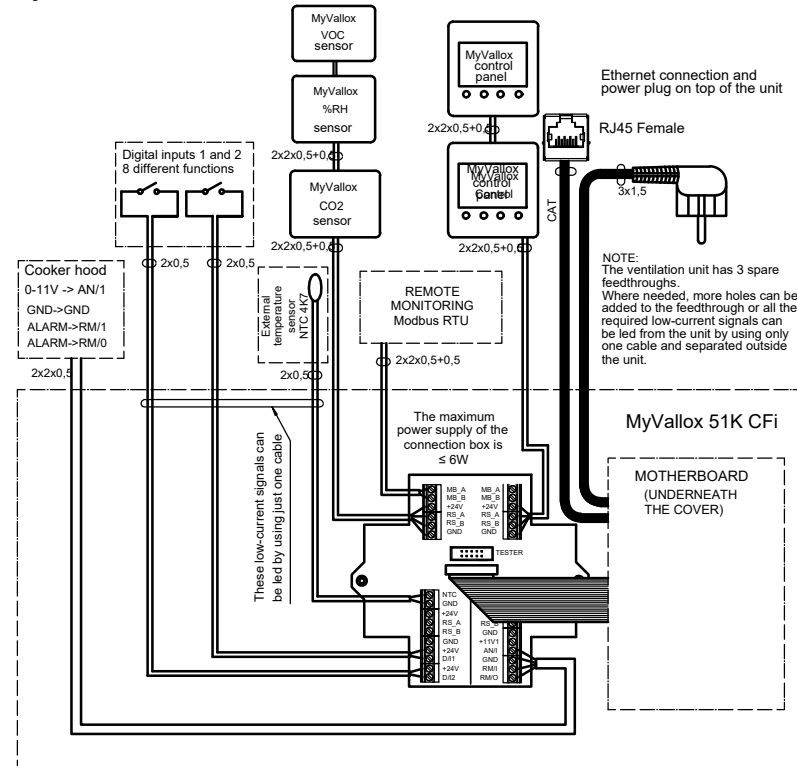

#### POWER SUPPLY

Maximum	≤6 W	MB_A	External Modbus A signal	D/I1	Digital input 1
MyVallox Control	1 W	MB_B	External Modbus B signal	D/I2	Digital input 2
MyVallox Touch	0.5 W	+24V	+24V voltage (DC)	11V1	11.1 V operating voltage
MyVallox %RH sensor	0.3 W	GND	Digital and analog ground potential	AN/I	Analog input 0-10 VDC
MyVallox CO2 sensor	1.2 W	RS_A	Local hardware Modbus A signal	RM/I	24V relay input
MyVallox VOC sensor	2 W	RS_B	Local hardware Modbus B signal	RM/O	24V relay output
External actuator or damper motor of the unit that receives feed from the relay		NTC	External temperature sensor connector		
Voltage	24 VDC				

Revision	Date	Person	Change

# VALLOX

Target  
Client name  
Address

ADJUSTMENT AND CONTROL  
DEVICE LIST

MyVallox 51K CFI

Drawer  
Person

Designer  
Person

Project number  
001

Date.  
Date

Revision  
...

Drawing number  
001

Page  
05 / 11

# EXTERNAL ELECTRICAL CONNECTION

## Vallox Captura cooker hood

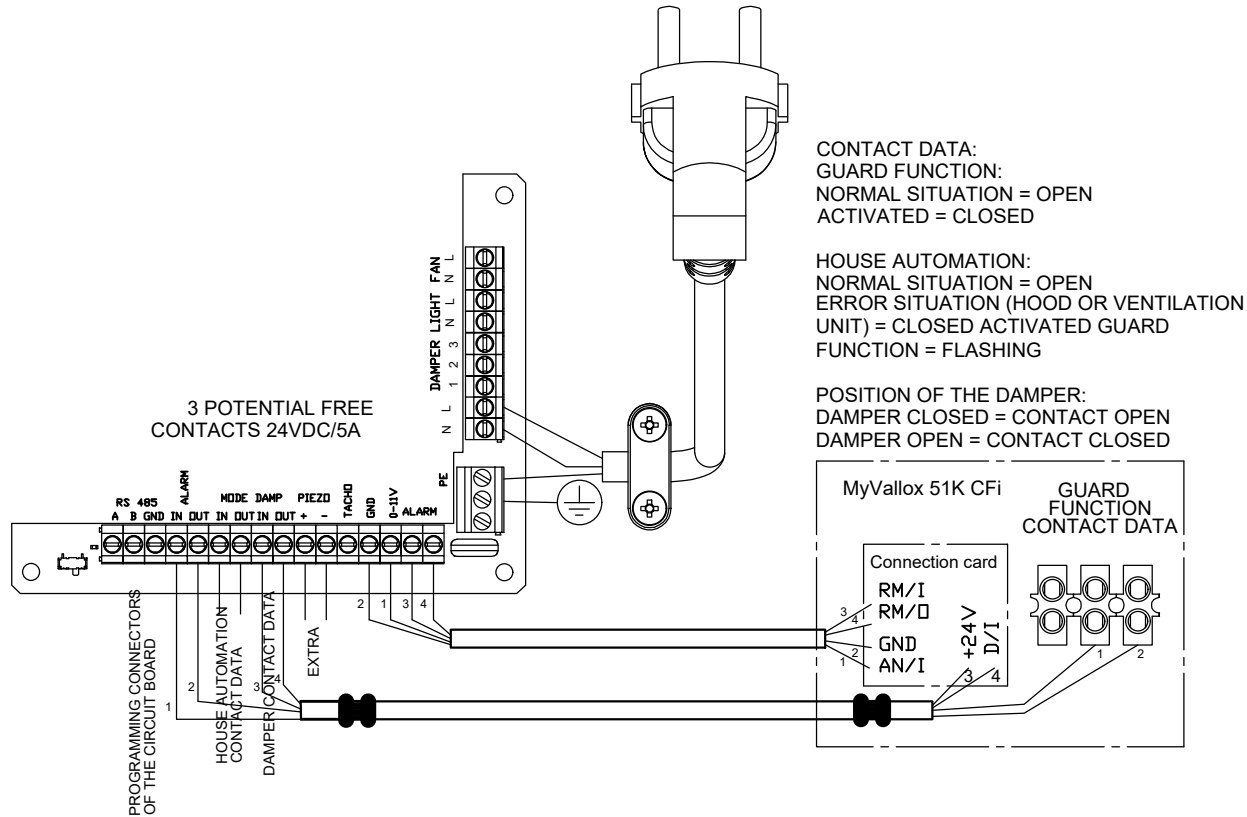

CONTACT DATA:  
 GUARD FUNCTION:  
 NORMAL SITUATION = OPEN  
 ACTIVATED = CLOSED

HOUSE AUTOMATION:  
 NORMAL SITUATION = OPEN  
 ERROR SITUATION (HOOD OR VENTILATION UNIT) = CLOSED ACTIVATED GUARD FUNCTION = FLASHING

POSITION OF THE DAMPER:  
 DAMPER CLOSED = CONTACT OPEN  
 DAMPER OPEN = CONTACT CLOSED

Revision	Date	Person	Change



Target  
 Client name  
 Address

ADJUSTMENT AND CONTROL  
 DEVICE LIST  
 MyVallox 51K CFI

Drawer Person	Designer Person	Project number 001	Date Date	Revision ...	Drawing number 001	Page 06 / 11
------------------	--------------------	-----------------------	--------------	-----------------	-----------------------	-----------------

## Vallox ventilation unit's control options

- Vallox Captura cooker hood
  - o local control
- MyVallox Touch / MyVallox Control control panel
  - o local control
- MyVallox Home - Web user interface
  - o local control in the home network
- MyVallox Cloud - Web user interface as a cloud service
  - o control via www.MyVallox.com
- Modbus RTU
  - o remote monitoring of the property via Modbus
- Digital and analogue inputs
  - o local control, cooker hood, or remote monitoring

## Fan speed control

- The fan speed is controlled by setting the unit to the Away, At Home, Boost or Custom mode and with the programmable input. The mode can be selected with any of the control options.
- The airflows of the supply air and extract air fans (l/s or m<sup>3</sup>/h) can be set in the At Home, Away and Boost modes. The airflow relation of the supply air and extract air fans is determined separately for each mode when the unit is commissioned. MyVallox CFI units can be set to % control, in which case to ventilation unit functions in a way similar to Vallox MV units.

## Airflow setting and adjustment in different modes

- The supply and extract airflows are determined separately for the At Home, Away, Boost and Custom modes and the programmable input when the unit is commissioned. Only the supply airflow is adjustable, and the extract airflow is adjusted automatically in relation to the supply airflow.

The airflows stay constant in spite of pressure losses caused by the duct system, wind, dirty filters, a frozen HR cell or defrosting cycles.

- o Away mode settings
  - Supply airflow setting: Set the supply airflow (l/s or m<sup>3</sup>/h).
  - Extract airflow setting: The extract airflow is adjusted automatically in relation to the supply airflow.
  - Supply air temperature setting: Set a target temperature for supply air.
  - Humidity and carbon dioxide control: The humidity and carbon dioxide controls are turned on or off.
- o At Home mode settings
  - Supply airflow setting: Set the supply airflow (l/s or m<sup>3</sup>/h).
  - Extract airflow setting: The extract airflow is adjusted automatically in relation to the supply airflow.
  - Supply air temperature setting: Set a target temperature for supply air.
  - Humidity and carbon dioxide control: The humidity and carbon dioxide controls are turned on or off.
- o Boost mode settings
  - Supply airflow setting: Set the supply airflow (l/s or m<sup>3</sup>/h).
  - Extract airflow setting: The extract airflow is adjusted automatically in relation to the supply airflow.
  - Supply air temperature setting: Set a target temperature for supply air.
  - Humidity and carbon dioxide control: The humidity and carbon dioxide controls are turned on or off.
  - Timer and its duration: In the Boost mode, the timer is turned on or off. When the timer goes off, the ventilation unit switches back to the previous mode.
- o Custom mode settings
  - Supply airflow setting: Set the supply airflow (l/s or m<sup>3</sup>/h).
  - Extract airflow setting: Set the extract airflow (l/s or m<sup>3</sup>/h).
  - Supply air temperature setting: Set a target temperature for supply air.
  - Timer and its duration: In the Custom mode, the timer is turned on or off. When the timer goes off, the ventilation unit switches back to the previous mode.
- o Programmable input settings
  - Supply airflow setting: Set the supply airflow (l/s or m<sup>3</sup>/h).
  - Extract airflow setting: Set the extract airflow (l/s or m<sup>3</sup>/h).
  - Supply air temperature setting: Set a target temperature for supply air.
  - Timer and its duration: The programmable input timer is turned on or off. When the timer goes off, the ventilation unit switches back to the previous mode.
  - The programmable input can only be turned on via digital inputs 1 or 2 or the Modbus.

Revision	Date	Person	Change			Target Client name Address		ADJUSTMENT AND CONTROL DEVICE LIST MyVallox 51K CFI								
				Drawer Person	Designer Person	Project number 001	Date. Date	Revision A	Drawing number 001	Page 07 / 11						

## Supply air temperature adjustment

- The adjustment options for the supply air temperature are supply air, extract air and cooling.
- The temperature range of supply air is +5...+25°C (recommended setting: +18°C).
- The post-heating radiator is only used in the heat recovery mode, during bypass defrosting and when the outdoor air temperature is lower than the heating season setting.

## Supply air adjustment options

- The supply air temperature is adjusted directly according to the target temperature by the means of heat recovery and post-heating.
  - Heat recovery and post-heating**
    - o If the temperature of the air passing through the HR cell is lower than the target supply air temperature and the outdoor air temperature is lower than the heating season setting, the HR cell and post-heating radiator adjust the temperature to the target temperature.
  - Heat recovery bypass**
    - o The HR cell is bypassed if the outdoor air temperature is higher than the heating season setting and the supply air temperature is higher than the target supply air temperature.
  - Cold recovery**
    - o The HR cell cools the outdoor air flowing in with extract air when the extract air temperature is at least two degrees lower than the outdoor air temperature.

## Extract air adjustment options:

- The supply air temperature is adjusted automatically based on the extract air temperature; in which case ventilation adapts to the indoor conditions dynamically.
  - Adjusting the target supply air temperature based on the extract air temperature**
    - o If the extract air temperature is lower than the target supply air temperature and the outdoor air temperature is lower than the heating season setting, the target supply air temperature is raised by max. 10°C.
    - o If the extract air temperature is higher than the target supply air temperature and the outdoor air temperature is lower than the heating season setting, the target supply air temperature is lowered by max. 10°C.
  - Heat recovery and post-heating**
    - o If the temperature of the air passing through the HR cell is lower than the target supply air temperature and the outdoor air temperature is lower than the heating season setting, the HR cell and post-heating radiator adjust the temperature to the target temperature.
  - Heat recovery bypass**
    - o The HR cell is bypassed if the outdoor air temperature is lower than the heating season setting and the supply air temperature is higher than the target supply air temperature.
  - Cold recovery**
    - o The HR cell cools the outdoor air flowing in with extract air when the extract air temperature is at least two degrees lower than the outdoor air temperature.

## Cooling

- The supply air temperature is controlled based on the extract air temperature, but ventilation can also be boosted when necessary.

## Heat recovery cell bypass

- The heat recovery cell bypass can be partial, full, or completely disabled.

### Partial heat recovery cell bypass

- o The system strives to maintain the target supply air temperature by bypassing the HR cell completely or partially if the outdoor air temperature is higher than the heating season setting.
- o If the outdoor air temperature is lower than the heating season setting, the HR cell is never bypassed.

### Full heat recovery cell bypass

- o The HR cell is fully bypassed when the outdoor air temperature is higher than the heating season setting.
- o The system switches to the cold recovery mode when all the following conditions are met.
  - The target supply air temperature is lower than the extract air temperature.
  - The outdoor air temperature is at least two degrees higher than the indoor air temperature.

### Heat recovery cell bypass disabled

- o The HR cell is never bypassed (exception: bypass defrosting).

## Humidity control

- The ventilation unit controls the fan speed according to the humidity level.
- The unit's extract air chamber has a humidity sensor for humidity control.
- A separate humidity sensor (accessory) can be installed in the apartment outside the unit.
- The humidity level can be determined automatically or manually.
  - o Determining the humidity level automatically takes approximately 10 hours from the start-up of the unit. After that, the unit updates the humidity level automatically.
  - o The humidity range for manual setting is 1-99%.
- The humidity control increases the fan speed up to the fan setting in the Boost mode. When the Boost mode is on, the fan speed can increase up to the maximum speed.
- The humidity control cannot decrease the fan speed to a point lower than the current mode's fan speed.
- NOTE! The ventilation unit is not able to increase the apartment's humidity level.

## Carbon dioxide control

- The ventilation unit controls the fan speed according to the carbon dioxide level.
- The unit's extract air chamber has a carbon dioxide sensor for carbon dioxide control.
- A separate carbon dioxide sensor (accessory) can be installed in the apartment outside the unit. The carbon dioxide adjustment range is 500-2000 ppm. The factory setting is 800 ppm.
- The carbon dioxide control increases the fan speed up to the fan setting in the Boost mode. When the Boost mode is on, the fan speed can increase up to the maximum speed.
- The carbon dioxide control cannot decrease the fan speed to a point lower than the current mode's fan speed.

## VOC control

- The ventilation unit controls the fan speed according to the VOC level
- This requires a VOC sensor (accessory) installed outside the unit.
- The VOC sensor feeds the ventilation unit a value proportional to the carbon dioxide level, the adjustment range of which is 500-2000 ppm.
- The VOC control increases the fan speed up to the fan setting in the Boost mode. When the Boost mode is on, the fan speed can increase up to the maximum speed.
- The VOC control cannot decrease the fan speed to a point lower than the current mode's fan speed.

## Ventilation unit's defrosting function

- The unit has an optional HR cell defrosting function. When the formation of ice has reached a certain point, the HR cell is defrosted. The cell is defrosted by extract air by bypassing the supply-side of the HR cell. The supply and extract airflow ratio is kept as constant as possible. During the defrosting cycles, the supply air temperature can be set between +12°C and +20°C. The unit uses the post-heating radiator and additional heating radiator (if applicable) to reach the target supply air temperature.
- Alternatively, the cell can be defrosted by stopping the supply air fan.
- If the unit is unable to defrost the HR cell within the set time due to, for example, a frozen ceiling lead-through, the unit runs a boosted defrosting cycle and increases the extract fan speed.
- The unit also allows manual defrosting, which can be activated from the different user interfaces.

## Boosted defrosting function

- Boosted defrosting function activates in exceptional conditions, if one of the following is met:
  - The supply air temperature is below 0°C after passing through the heat recovery cell.
  - The extract air temperature is below 0°C.
  - The calculated defrosting efficiency of the heat recovery cell indicates that the cell is frozen.
- During the boosted defrosting function:
  - The supply air fan air flow is limited according to the supply air temperature setting.
  - The extract air fan is running at full speed.
  - The maximum duration of the function is 60 minutes.

Revision	Date	Person	Change			Target		ADJUSTMENT AND CONTROL		
						Client name		DEVICE LIST		
						Address		MyVallox 51K CFI		
						Drawer	Designer	Project number	Date.	Revision
				Person	Person	001	Date	A	001	08 / 11

## Safety devices

- Excess heat protectors of the post-heating radiator: The radiator is equipped with two excess heat protectors. One of them has automatic recovery (BTS) and the other is the cut-off type (BTC).
- The fans have automatic excess heat protectors.
- The door's safety switch cuts off power to the unit when the door is opened. Regardless of this, the unit should always be unplugged before starting maintenance work.
- MyVallox 119 CFI, MyVallox 149 CFI, MyVallox 51 CFI and MyVallox 51K CFI units are not equipped with the door's safety switch.

## Alarms and reminders

- In the event of a critical malfunction, the ventilation unit stops. There are also malfunctions that trigger an alarm but do not stop the ventilation unit.
- Critical malfunctions that stop the unit:
  - o The supply air or extract air fan has stopped.
  - o The temperature sensor is damaged.
  - o The supply or extract air sensor is damaged (only CFI models).
  - o The supply air temperature is permanently under +5°C.
- Malfunctions that do not stop the unit:
  - o Communication error between the controller and the mother board.
  - o High supply air temperature.
  - o The target supply or extract airflow is not achieved (only CFI models).
- The 24 V voltage-free malfunction relay provides information on unit malfunctions. In the event of a malfunction, the relay tips open. The relay tips open in the following situations:
  - o The supply air or extract air fan has stopped.
  - o The temperature sensor is damaged.
  - o The ventilation unit has shut down (operation mode).
  - o The supply or extract air sensor is damaged (only CFI models).
  - o The supply air temperature is permanently under +5°C.
- The maintenance reminder reminds the user to change the filter and carry out basic maintenance every four months (factory setting). The reminder interval can be changed, the reminder can be disabled, or it can be acknowledged automatically. See the manual for the maintenance measures to be carried out.
- Information is also accessible through the Modbus.
- Alternatively, the relay can be programmed with the following functions:

Relay function	Tips closed	Tips open
Maintenance reminder	normal operation	maintenance reminder
Malfunction	normal operation	malfunction
Malfunction and maintenance reminder	normal operation	maintenance reminder/malfunction
Emergency stop	normal operation	emergency stop
Bypass flap mode	winter setting	summer setting
Duct radiator control	on	off
Air heating	on	off
On/off status	on	off

## Digital controls (2 pcs)

- The unit has two digital inputs that can be set to perform various functions according to the table below.
- The digital controls can be implemented by a push button or rocker switch. Both digital inputs recognise the switch type automatically.
- The push button functions are activated whenever the push button is released. A function activated by the push button can be cancelled by keeping the push button pressed down for five seconds.
- When using the push button, the selected mode is activated for the period set in the timer. When the timer goes off, the unit returns to normal operation.
- The rocker switch functions are activated and deactivated according to the rocker switch mode.
- When the rocker switch is switched to ON position for the first time, it takes five seconds for the rocker switch function to activate. After that, the function will activate immediately.
- The rocker switch can also be used to activate a push button function by keeping it in the ON position for less than five seconds. The push button function can be cancelled by keeping the switch in the ON position for over five seconds.

Function	Rocker switch		Tips open 24 V pulse for less than 5 seconds
	0 V	24 V	
Custom mode	Off	On	On for the set time
At Home/Away control	At Home	Away	Switches the mode between At Home and Away
Emergency stop	Unit shuts down	Normal operation	Unit shuts down
Boost	Off	On	On for the set time
Direct cell bypass control	Automatic mode	Bypass mode	Switches the bypass mode
Week clock	Off	On	Switches the week clock mode
Programmable input	Off	On	On for the set time

## Programmable input (1)

- One programmable digital input can be installed to the ventilation unit.
- The programmable digital input can be used to switch a pre-set function on (24 V) or off (0 V). Function settings:
  - o Supply and extract air fan speeds.
  - o Supply air temperature setting.
  - o Duration.

## Analog input (1)

The analogue input control options:

Function	Voltage rating
Stop, Away, At Home, Boost	Stop = 0-1 V, Away = 2-4 V, At Home = 5-7 V, Boost = 8-10 V
Supply air temperature control	0-10 V = +5... +25°C

Revision	Date	Person	Change	 Target Client name Address		ADJUSTMENT AND CONTROL DEVICE LIST				
						MyVallox 51K CFI				
				Drawer Person	Designer Person	Project number 001	Date. Date	Revision A	Drawing number 001	Page 09 / 11

## Modbus

- Two-way traffic via Modbus (RTU)
  - o The Modbus can be used to control and read the unit's modes
  - o Ventilation unit settings (e.g. adjusting the supply air temperature)
  - o Malfunction analysis
  - o More information is available in the separate Modbus register

## Control and sensor power consumption

The total power of the devices connected to the ventilation unit must not exceed 6 W. See below the power consumption of each device:

- o Controller 1 W
- o Humidity sensor 0.3 W
- o Carbon dioxide sensor 1.2 W
- o VOC sensor 2 W

## Control of an external liquid radiator through the ventilation unit's 24 V relay

### Liquid radiator in the outdoor air duct

- The ventilation unit measures the outdoor temperature with an NTC temperature sensor (accessory) installed in the outdoor air duct before the liquid radiator.
- Heating (optional)
  - o If the outdoor air temperature falls below the winter setting, the radiator is turned on.
  - o If the outdoor air temperature rises above the winter setting, the radiator is turned off.
- Cooling
  - o If the outdoor air temperature is higher than the summer setting and the supply air temperature rises one degree above the target supply air temperature, the radiator is turned on.
  - o If the supply air temperature falls below the target supply air temperature, the radiator is turned off.
- Automatic condensation limit (optional)
  - o The ventilation unit measures the dew point based on the temperature and humidity and does not cool the supply air below this temperature.
  - o This requires an NTC temperature sensor installed in the duct.

### Liquid radiator in the supply air duct

- The ventilation unit measures the supply air temperature with an NTC temperature sensor (accessory) installed in the supply air duct after the liquid radiator or in the room. The unit strives to maintain the target supply air temperature. If the target temperature is not reached by partially bypassing the HR cell, the duct radiator is turned on.
- Ventilation heating
  - o If the supply air or room air temperature falls below the target temperature, the radiator is turned on.
  - o If the supply air or room air temperature rises above the target temperature, the radiator is turned off.
- Cooling
  - o If the outdoor air temperature is higher than the summer setting and the supply air or room air temperature rises one degree above the target supply air temperature, the radiator is turned on.
  - o If the supply air or room air temperature falls below the target supply air temperature, the radiator is turned off.
- Automatic condensation limit (optional)
  - o The ventilation unit measures the dew point based on the temperature and humidity and does not cool the supply air below this temperature.
  - o This requires an NTC temperature sensor installed in the duct.
- Freeze protection of the liquid radiator inside the unit (245 VKL)
  - o The liquid radiator inside the unit is protected by programmable freeze protection.
  - o Both of the unit's fans stop if the supply air temperature falls below +5°C and the outdoor air temperature is below 0°C.
  - o The fans are turned on when the supply air temperature is above +5°C.

Revision	Date	Person	Change			Target Client name Address		ADJUSTMENT AND CONTROL DEVICE LIST MyVallox 51K CFI		
				Drawer Person	Designer Person	Project number 001	Date. Date	Revision A	Drawing number 001	Page 10 /11

MODBUS (RTU) REGISTERS

Temperatures are in centikelvins.  
 - Temperature in Celsius degrees = (temperature in centikelvins - 27315) / 100  
 - Temperature in centikelvin degrees = (temperature in Celsius degrees \* 100) + 27315

All registers are holding registers.

Supported function codes:  
 - Read multiple holding registers, 0x03  
 - Write one holding register, 0x06  
 - Write multiple holding registers, 0x10

Writing to read-only holding registers is prohibited and will cause an error code.

VARIABLE NAME	R/RW	ADDRESS	MIN	MAX	TYPE	DESCRIPTION
SWITCH UNIT ON/OFF	R/W	4x4610	0	5		Unit state, 0=normal, 5=off
HONE/AWAY	R/W	4x4609	0	1		Use mode (0=Away, 1=Hone)
HR CELL STATUS	R	3x4616	0	3		0=Heat recovery, 1=Cool recovery, 2=Bypass, 3=Defrost
UNIT MIN AIRFLOW	R	3x46032			flow	Unit minimum air-flow
UNIT MAX AIRFLOW	R	4x46031			flow	Unit maximum air-flow
AWAY AIRFLOW SETTING	R/W	4x20501	unit_min	unit_max	flow	Airflow in Away-mode
HONE AIRFLOW SETTING	R/W	4x20507	unit_min	unit_max	flow	Airflow in Hone-mode
BOOST AIRFLOW SETTING	R/W	4x20513	unit_min	unit_max	flow	Airflow in Boost-mode
AWAY SUPPLY TEMP SETTING	R/W	4x20502	27815	29815	cK	Supply air set temperature in Away-mode
HONE SUPPLY TEMP SETTING	R/W	4x20508	27815	29815	cK	Supply air set temperature in Hone-mode
BOOST SUPPLY TEMP SETTING	R/W	4x20514	27815	29815	cK	Supply air set temperature in Boost-mode

VARIABLE NAME	R/RW	ADDRESS	MIN	MAX	TYPE	DESCRIPTION
OUTDOOR AIR TEMPERATURE	R	3x4356	21000	33224	cK	Outdoor air temperature

VARIABLE NAME	R/RW	ADDRESS	MIN	MAX	TYPE	Description
EXTRACT AIR TEMPERATURE	R	3x4354	21000	33224	cK	Extract air temperature
RH VALUE	R	3x4363	0	100	%	Relative humidity
CO2 VALUE	R	3x4364	0	10000	PPM	Carbon dioxide level

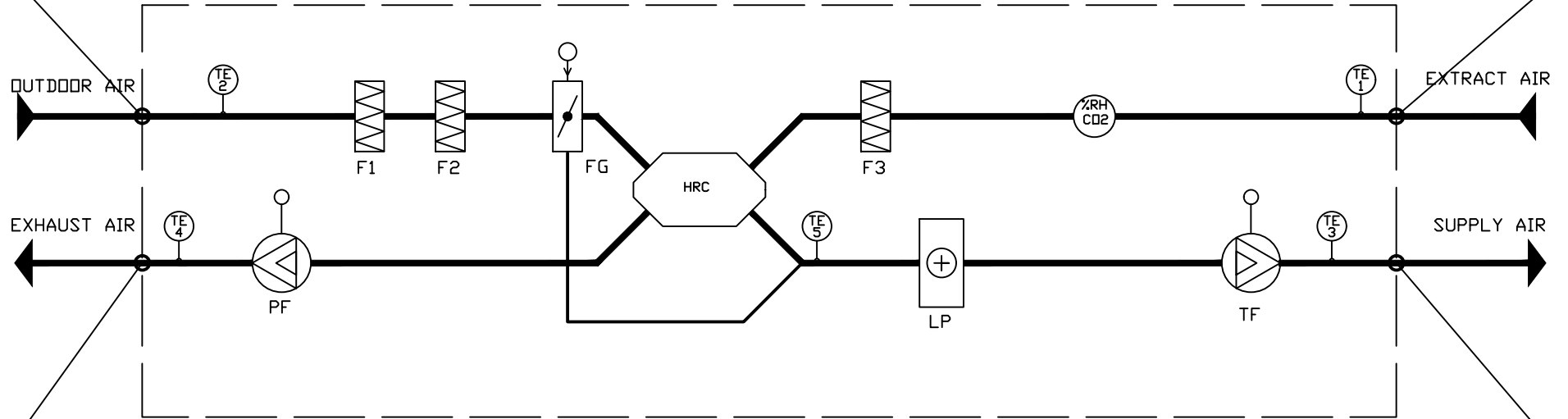

VARIABLE NAME	R/RW	ADDRESS	MIN	MAX	TYPE	DESCRIPTION
EXHAUST AIR TEMPERATURE	R	3x4355	21000	33224	cK	Exhaust air temperature
CFI EXTRACT AIRFLOW	R	3x46004	0	unit_max	flow	Extract air flow

VARIABLE NAME	R/RW	ADDRESS	MIN	MAX	TYPE	DESCRIPTION
SUPPLY AIR TEMPERATURE	R	3x4358	21000	33224	cK	Supply air temperature
CFI SUPPLY AIRFLOW	R	3x40063	0	unit_max	flow	Supply air flow

Revision	Date	Person	Change



Target  
Client name  
Address

ADJUSTMENT AND CONTROL  
DEVICE LIST  
MyVallox 51K CFI

Drawer Person	Designer Person	Project number 001	Date Date	Revision A	Drawing number 001	Page 11 / 11
------------------	--------------------	-----------------------	--------------	---------------	-----------------------	-----------------