

## MyVALLOX MODBUS CONFIGURATION

### Tekniska instruktioner

MyVallox-ventilationsaggregat kan styras med Modbus RTU-kompatibla fastighetsautomationssystem. Samma Modbus-buss kan kopplas till upp till 32 MyVallox-ventilationsaggregat. Vid styrning av ett ventilationsaggregat med ett fastighetsautomationssystem kan man till exempel avläsa olika sensorvärden och ändra ventilationsaggregatets läge.

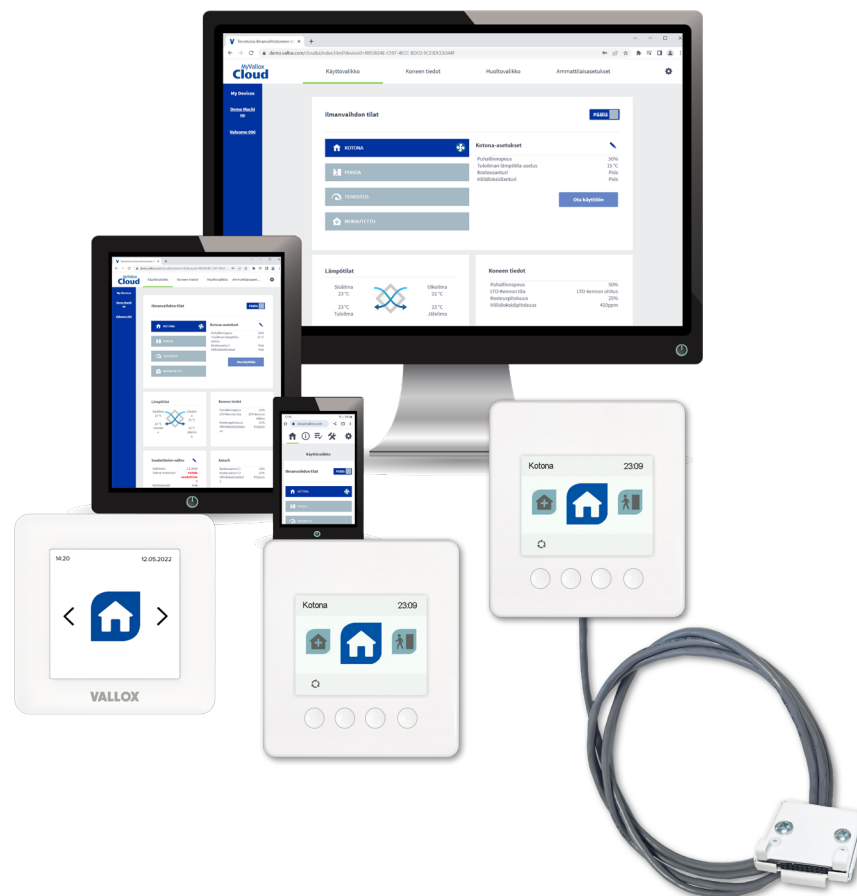

## ALLMÄNT

Alla ändringar som görs via användargränssnittet kan också göras via Modbus RTU. Modbus TCP stöds inte.

Uppgiftsformen är alltid 16 bitars siffra utan förtecken, och alla register innehåller heltal utan bit-masked-strukturer.

Alla register är hållregister.

Som skalningskoefficient används 1, förutom för temperaturer (cK).

### Understödda funktionskoder

- Läs hållregister, 0x03
- Skriv enkelt register, 0x06
- Skriv flera register, 0x10

Det är förbjudet att skriva i odefinierade register. Det orsakar en felkod. Detta ska beaktas när man skriver flera register samtidigt.

Det är förbjudet att skriva i skrivskyddade register. Det orsakar en felkod.

Det är förbjudet att skriva värden utanför det tillåtna intervallet. Det orsakar en felkod.

## MODBUS-INSTÄLLNINGAR

Om ventilationsaggregatet till exempel är anslutet till fastighetsautomationssystemet via Modbus-bussen, ska följande Modbus-inställningar göras:

- Ventilationsaggregatets Modbus-adress
- Modbus överföringshastighet
- Modbus-paritet
- Modbus-stoppsbit (stop bit)

I dessa instruktioner anges hur inställningarna görs med MyVallox Control-panelen, MyVallox Touch-kontrollpanelen eller www-gränssnittet. Med hjälp av dessa instruktioner kan också enskilda inställningar, såsom Modbus-adressen, definieras.

## ÖVERGÅNG MELLAN LÄGEN

Ventilationsaggregat har två grundlägen: Hemma och Borta. Någondera är alltid valt.

- Grundläget kan avläsas och ställas in i registret 4609, 0 = Hemma-läge och 1 = Borta-läge.

### Tidsinställda lägen

Ventilationsaggregat har också tre tidsinställda lägen: Forcering, Anpassat och Programmerbar. De tidsinställda lägena häver grundläget tillfälligt. Det önskade läget aktiveras genom att man skriver den önskade tiden i minuter och läget i timerregistret. Läget aktiveras och timerregistret börjar räkna bakåt. När timerregistren för alla tidsinställda lägen är i noll, går ventilationsaggregatet tillbaka till grundläget.

- 4612 = Forcering-lägets timerregister
- 4613 = Anpassat-lägets timerregister
- 4614 = Självprogrammerbara lägets timerregister

Det tidsinställda läget kan ställas in att fortsätta tills vidare genom att ange värdet 65535 i lägets timerregister. Detta förhindrar timern från att räkna bakåt, tills timerregistret ställs om manuellt eller läget ändras från ett annat användargränssnitt.

Timer kan också deaktiveras från motsvarande timerbrytarregister, 0 = timer av och 1 = timer på. Detta förhindrar också användning av timer via alla användargränssnitt.



#### OBS

Användning av MyVallox digitala ingång för att ändra lägena ändrar också på innehållet i timerbrytarregistren.

- 21766 = Register som tillåter tidsinställning av forceringsläget
- 21767 = Register som tillåter tidsinställning av anpassningsläget
- 21772 = Register som tillåter tidsinställning av det självprogrammerbara läget

## EXEMPEL

### Aktivering av Anpassat-läget för 15 minuter

- Skriv 15 i register 4613.
- Skriv 1 i register 21767 (om det inte redan finns där).

### Aktivering av Forcering-läget utan timer (läget hålls påslaget)

Metod 1:

- Skriv 65535 i register 4612.

Metod 2:

- Skriv vilket som helst värde (annat än 0) i register 4612.
- Skriv 0 i register 21766.

### Avslutning av Forcering-läget, återgång till det valda grundläget (Borta/Hemma)

- Skriv 0 i register 4612.
- Alternativt kan du skriva 0 i registren 4613, 4614 för att avsluta alla tidsinställda lägen.

### Övergång från Hemma-läge till Borta-läge

- Skriv 1 i register 4609.
- Alternativt kan du skriva 0 i registren 4612, 4613, 4614 för att avsluta alla tidsinställda lägen.

## LÄGESPRIORITERINGAR

Om flera än ett läge är aktiva på en gång, upphäver ett läge med högre prioritering de övriga lägena. Om t.ex. Anpassat-läget och Forcering-läget är aktiva samtidigt, använder ventilationsaggregatet Anpassat-läget. Lägenas prioriteringsordning är följande:

1. Självprogrammerbara läget
2. Anpassat-läget
3. Forcering-läget
4. Hemma/Borta-(grund)läget

## AVSLAGNING AV STRÖMMEN FRÅN AGGREGATET

Strömmen kan slås av från aggregatet genom att skriva "5" i register 4610, och strömmen kan slås på genom att skriva "0" i register 4610.

## UPPGIFTERNAS OMVANDLINGSFORMLER



### OBS

Temperaturerna anges i centKelvin.

- Temperatur i Celsius = (temperatur i centKelvin-27315)/100
- Temperatur i centKelvin = (temperatur i Celsius\*100)+27315

## AGGREGATETS FELLÄGEN

Felmeddelanden kan läsas i register 4621. Register 4621 går i läge 1 endast när ett fel som stoppar aggregatet (kritiskt) aktiveras. Fel som inte stoppar aggregatet ändrar inte på registrets läge.

0 = normal funktion, 1 = kritiskt fel, aggregatet har stannat. Feltypen kan avläsas i MyVallox-användargränssnittet eller via modbus enligt anvisningen nedan.

register	namn	R/RW	min	max	type	description
3x4621	CRITICAL FAULT ACTIVE	R	0	1		Unit critical fault active, unit is off

### Avläsning av olika fellägen

Register 36865 visar det totala antalet kvitterade och aktiva fel.

register	namn	R/RW	min	max	type	description
3x36865	TOTAL FAULT COUNT	R	0	33		Total count of faults

### Avläsning av fel

Tabellen fylls i i den ordning som felen uppkommer. Om det totala antalet fel till exempel är 1, avläses felkoden i register 36866, och i register 36871 om felet är aktivt eller kvitterat.

register	namn	R/RW	min	max	type	description
3x36866	FAULT 1	R	0	50		Fault 1 code
4x36871	FAULT 1 ACTIVITY	R/W	0	1		Fault 1 state [0= active,1= solved]
3x36872	FAULT 2	R	0	50		Fault 2 code
4x36877	FAULT 2 ACTIVITY	R/W	0	1		Fault 2 state [0= active,1= solved]
3x36878	FAULT 3	R	0	50		Fault 3 code
4x36883	FAULT 3 ACTIVITY	R/W	0	1		Fault 3 state [0= active,1= solved]
3x36884	FAULT 4	R	0	50		Fault 4 code
4x36889	FAULT 4 ACTIVITY	R/W	0	1		Fault 4 state [0= active,1= solved]
3x36890	FAULT 5	R	0	50		Fault 5 code
4x36895	FAULT 5 ACTIVITY	R/W	0	1		Fault 5 state [0= active,1= solved]
3x36896	FAULT 6	R	0	50		Fault 6 code
4x36901	FAULT 6 ACTIVITY	R/W	0	1		Fault 6 state [0= active,1= solved]
3x36902	FAULT 7	R	0	50		Fault 7 code
4x36907	FAULT 7 ACTIVITY	R/W	0	1		Fault 7 state [0= active,1= solved]
3x36908	FAULT 8	R	0	50		Fault 8 code
4x36913	FAULT 8 ACTIVITY	R/W	0	1		Fault 8 state [0= active,1= solved]
3x36914	FAULT 9	R	0	50		Fault 9 code
4x36919	FAULT 9 ACTIVITY	R/W	0	1		Fault 9 state [0= active,1= solved]
3x36920	FAULT 10	R	0	50		Fault 10 code
4x36925	FAULT 10 ACTIVITY	R/W	0	1		Fault 10 state [0= active,1= solved]

### Felkoders förklaringar

fault code	explanation	fault code	explanation
0	No fault	8	Supply air from HR cell sensor failure
1	Extract fan failure	9	Extract airflow sensor
2	Supply fan failure	10	Optional temperature sensor failure
3	Supply airflow sensor	11	High supply air temperature
4	Extract air temperature sensor failure	12	Water radiator freezing prevention
5	Outdoor air temperature sensor failure	23	Low supply air temperature
6	Supply air temperature sensor failure	25	Supply airflow is not achieved
7	Exhaust air temperature sensor failure	26	Extract airflow is not achieved

## Modbus-inställningar med MyVallox-kontrollpaneler

=> Professionella inställningar

=> 1/0- och bussinställningar

=> Modbus-inställningar

=> Ange ventilationsaggregatets Modbus-adress. Du kan välja en adress i intervallet 1–247.

=> Ange Modbus överföringshastighet. Alternativen är 9600, 19200, 38400, 57600 eller 115200.

=> Ställ in Modbus-knapparna. Alternativen är:

- ingen — Ingen paritet
- jämn — Jämn paritet
- udda — Udda paritet.

=> Ställ in Modbus-bussens stoppbit (stop bit). Alternativen är 1 eller 2.

=> Bekräfta inställningarna genom att klicka på **Godkänn**.

## Modbus-inställningar med WWW-gränssnitt

MyVallox-ventilationsaggregatets Modbus-inställningar kan också göras via WWW-gränssnittet. Det finns två alternativ:

- MyVallox Home-lokalnätanslutning
- MyVallox Cloud-molntjänst

Det rekommenderas att Modbus-inställningarna görs vid ibruktagningen så att de sparas automatiskt som ibruktagningsinställningar.

1. Välj Professionella inställningar.
2. Rulla vyn tills du ser Modbus-inställningarna.



3. Klicka på **Redigera**:



4. Modbus-inställningarnas vy öppnas i redigeringsläget:

5. Ange ventilationsaggregatets Modbus-adress i Adress-fältet. Du kan ställa in adressen med det blå skjutreglaget. Du kan välja en adress i intervallet 1–247.
6. Välj Modbus-bussens anslutningshastighet i Överföringshastighet-förteckningsmenyn (Baud rate). Alternativen är 9600, 19200, 38400, 57600 eller 115200.
7. Välj Modbus-bussens paritet i Paritet-förteckningsmenyn. Alternativen är:
  - ingen — Ingen paritet
  - jämn — Jämn paritet
  - udda — Udda paritet.
8. Ställ in Modbus-bussens stoppbit i Stoppbit-fältet. Alternativen är 1 eller 2.
9. Klicka på **Godkänn**.
10. Nu har Modbus-inställningarna gjorts.

ELSCHEMA

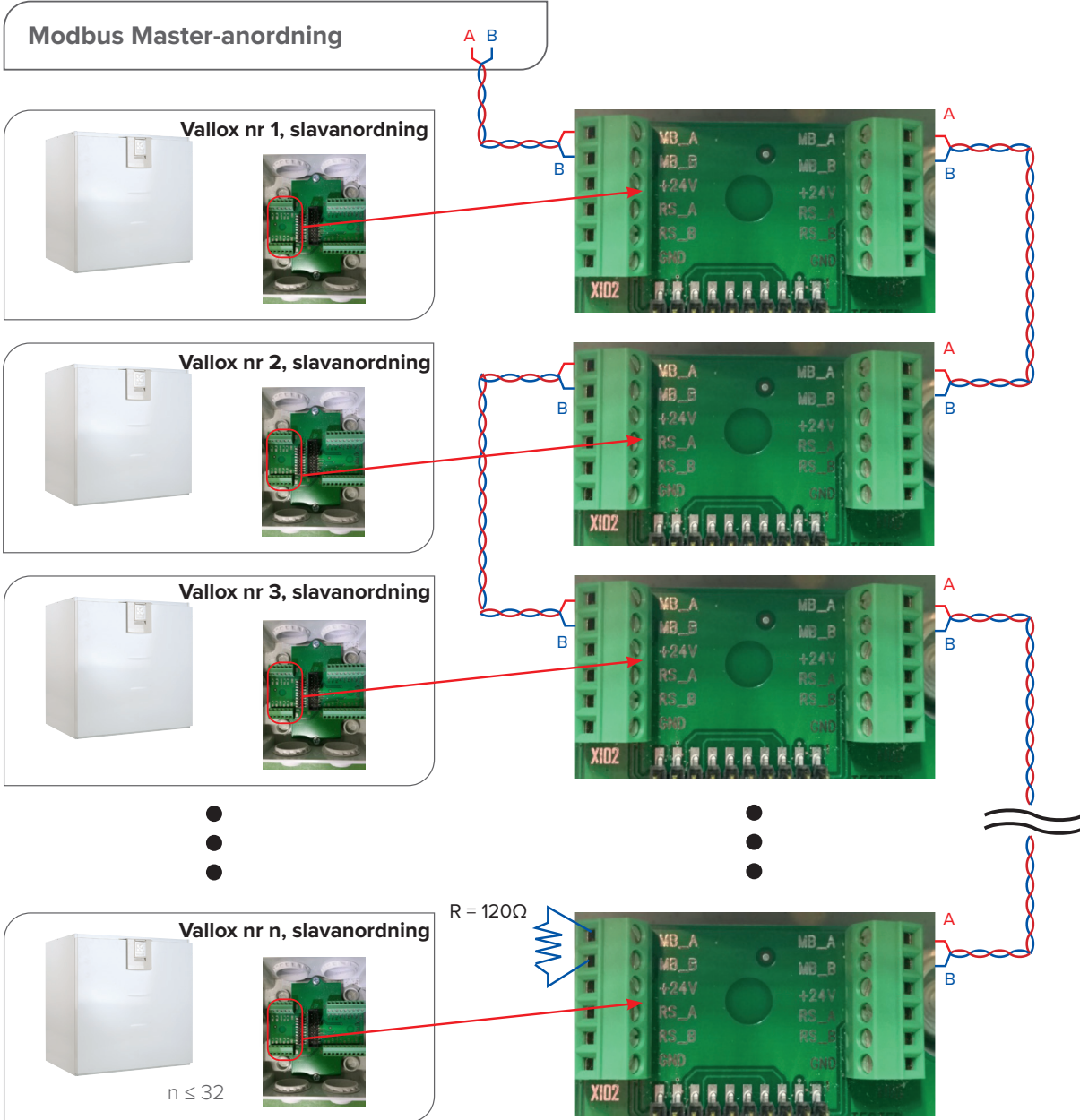

## MODBUS-REGISTER

### Avläsning av temperatur- och sensoruppgifter

Temperaturerna avläses i centKelvin.

Omvandlingsformel: Temperatur i Celsius = (temperatur i centKelvin-27315)/100

register	namn	R/RW	min	max	type	description
3x4354	EXTRACT AIR TEMPERATURE	R	21000	33224	cK	Read current extract air temperature in cK
3x4355	EXHAUST AIR TEMPERATURE	R	21000	33224	cK	Read current supply air from cell temperature in cK
3x4356	OUTDOOR AIR TEMPERATURE	R	21000	33224	cK	Read current outdoor air temperature in cK
3x4357	SUPPLY CELL AIR TEMPERATURE	R	21000	33224	cK	Read current supply air from cell temperature in cK
3x4358	SUPPLY AIR TEMPERATURE	R	21000	33224	cK	Read current supply air temperature in cK
3x4389	OPTIONAL SENSOR TEMPERATURE	R	20000	33224	cK	Read current optional external temperature in cK
3x4363	RH VALUE	R	0	100	RH%	Read current RH measurement, 0 = No sensor installed. Shows the highest value if multiple sensors installed.
3x4364	CO2 VALUE	R	0	10000	PPM	Read current CO2 value, 0 = No sensor installed Shows the highest value if multiple sensors installed.

### Avläsning och skrivande av temperatur- och sensorinställningar

Fukt- och koldioxidssensorer

register	namn	R/RW	min	max	type	description
4x20490	RH TRESHOLD	R/W	0	65535	%	Set and read the RH level, 65535 = RH level calibration on-going
4x20499	AWAY RH CONTROL	R/W	0	1		Read and set RH control in use in away mode [0=not in use, 1= in use]
4x20505	HOME RH CONTROL	R/W	0	1		Read and set RH control in use in at home mode [0=not in use, 1= in use]
4x20511	BOOST RH CONTROL	R/W	0	1		Read and set RH control in use in boost mode [0=not in use, 1= in use]
4x20491	CO2 THRESHOLD	R/W	500	2000	PPM	Set and read the CO2 threshold
4x20500	AWAY CO2 CONTROL	R/W	0	1		Read and set CO2 control in use in away mode [0=not in use, 1= in use]
4x20506	HOME CO2 CONTROL	R/W	0	1		Read and set CO2 control in use in at home mode [0=not in use, 1= in use]
4x20512	BOOST CO2 CONTROL	R/W	0	1		Read and set CO2 control in use in boost mode[0=not in use, 1= in use]

### Tilluftens temperaturinställningar

Temperaturerna skrivs och avläses i centKelvin.

Omvandlingsformel: Temperatur i centKelvin = (temperatur i Celsius\*100)+27315

register	namn	R/RW	min	max	type	description
4x20502	AWAY SUPPLY TEMP SETTING	R/W	27815	29815	cK	Read and set supply air temperature setting in away mode (cK)
4x20508	HOME SUPPLY TEMP SETTING	R/W	27815	29815	cK	Read and set supply air temperature setting in at home mode (cK)
4x20514	BOOST SUPPLY TEMP SETTING	R/W	27815	29815	cK	Read and set supply air temperature setting in boost mode (cK)
4x20497	CUSTOM SUPPLY TEMP SETTING	R/W	27815	29815	cK	Read and set supply air temperature setting in custom mode (cK)
4x20493	PROG. INPUT TEMP SETTING	R/W	27815	29815	cK	Read and set supply air temperature setting in programmable input (cK)

## Styrning av ventilationsaggregatet

register	namn	R/RW	min	max	type	description
4x4609	HOME/AWAY/ AUTOMATIC	R/W	0	2		Set the unit to At Home or Away or Automatic mode [0=Home, 1=Away, 2=Automatic]
4x4610	SWITCH UNIT ON/OFF	R/W	0	5		Switch the unit off or on [0=on, 5 = off]

### Vallox MV-aggregat (%-styrning)

register	namn	R/RW	min	max	type	description
4x20501	AWAY SPEED SETTING	R/W	0	100	%	Read or set the fan speed setting for away mode, 0-100%
4x20507	HOME SPEED SETTING	R/W	0	100	%	Read or set the fan speed setting for at home mode, 0-100%
4x20513	BOOST SPEED SETTING	R/W	0	100	%	Read or set the fan speed setting for boost mode, 0-100%
4x20487	CUSTOM EXTRACT SPEED SETTING	R/W	0	100	%	Read or set the Extract fan speed setting at custom mode, 0-100%
4x20488	CUSTOM SUPPLY SPEED SETTING	R/W	0	100	%	Read or set the Supply fan speed setting at custom mode, 0-100%
4x20494	PROG. INPUT EXTRACT SPEED SETTING	R/W	0	100	%	Read or set the Extract fan speed at programmable input, 0-100%
4x20495	PROG. INPUT SUPPLY SPEED SETTING	R/W	0	100	%	Read or set the Supply fan speed at at programmable input, 0-100%
4x20485	EXTR_FAN_BALANCE_BASE	R/W	0	100	%	Extract fan speed balance ground value
4x20486	SUPP_FAN_BALANCE_BASE	R/W	0	100	%	Supply fan speed balance ground value

### MyVallox CFi-aggregat (l/s eller m<sup>3</sup>/h)

Obs! Luftmängden kan inte ställas in som större eller mindre än ventilationsaggregatets maximala eller minimala luftflöde.

- MyVallox CFi-aggregatets maximala luftflöde (unit\_max) kan läsas i register 46031
- MyVallox CFi-aggregatets minimala luftflöde (unit\_min) kan läsas i register 46032

register	name	R/RW	min	max	type	description
4x20501	AWAY AIRFLOW SETTING	R/W	unit_min	unit_max		Read or set the fan speed setting for away mode (l/s or m3/h)
4x20507	HOME AIRFLOW SETTING	R/W	unit_min	unit_max		Read or set the fan speed setting for at home mode (l/s or m3/h)
4x20513	BOOST AIRFLOW SETTING	R/W	unit_min	unit_max		Read or set the fan speed setting for boost mode (l/s or m3/h)
4x20487	CUSTOM EXTRACT AIRFLOW SETTING	R/W	unit_min	unit_max		Read or set the Extract fan speed setting at custom mode (l/s or m3/h)
4x20488	CUSTOM SUPPLY AIRFLOW SETTING	R/W	unit_min	unit_max		Read or set the Supply fan speed setting at custom mode (l/s or m3/h)
4x20494	PROG. INPUT EXTRACT AIRFLOW SETTING	R/W	unit_min	unit_max		Read or set the Extract fan speed at programmable input (l/s or m3/h)
4x20495	PROG. INPUT SUPPLY AIRFLOW SETTING	R/W	unit_min	unit_max		Read or set the Supply fan speed at at programmable input (l/s or m3/h)
4x32779	CFI LIMITER	R/W	0	1	off/on	Enables CF limiter [0 = off, 1 = on]
3x32780	CFI LIMITER ACTIVE	R	0	1	false/true	Limiter activated [0 = no, 1 = yes]
3x32781	CFI SUPPLY FANLOAD LEVEL	R	0	10		Supply fan load indicator, scales from 0–10 [0 = no load, 10 = max load]
3x32782	CFI EXTRACT FANLOAD LEVEL	R	0	10		Extract fan load indicator, scales from 0–10 [0 = no load, 10 = max load]
4x46031	CONSTANT FAN MAX VALUE	R/W	0	2000	l/s or m <sup>3</sup> /h	Units defined the maximum airflow. The default value is taken from the configuration number and edited by airflow tests. Editing this by hand is not recommended.
4x46032	CONSTANT FAN MIN VALUE	R/W	0	300	l/s or m <sup>3</sup> /h	Units defined minimum airflow. The default is taken from the configuration number. Editing this by hand is not recommended.

## Timer

register	namn	R/RW	min	max	type	description
4x4612	BOOST MODE TIMER	R/W	0	65535	minutes	Set and read Boost timer time (time that is set in the timer). Timer is enabled from register 21766. 65535 = Timed mode runs indefinitely. The timer is not used when 65535 is written to this register.
4x20544	BOOST MODE TIME	R/W	1	65535	minutes	Set and read Boost timer current value, decreases when custom boost is controlling the unit.
4x21766	BOOST MODE ENABLE TIMER	R/W	0	1		Boost timer enabled [0=timer disabled, 1= timer enabled]
4x4613	CUSTOM MODE TIME	R/W	0	65535	minutes	Set and read Custom timer time (time that is set in the timer). Timer is enabled from register 21767. 65535 = Timed mode runs indefinitely. The timer is not used when 65535 is written to this register.
4x20545	CUSTOM MODE TIME	R/W	1	65535	minutes	Set and read custom timer current value, decreases when custom mode is controlling the unit.
4x21767	CUSTOM MODE ENABLE TIMER	R/W	0	1		Enable or disable custom timer [0=timer disabled, 1= timer enabled]
4x4614	PROG. INPUT TIMER	R/W	0	65535	minutes	Set and read programmable input timer time (time that is set in the timer). Timer is enabled from 21772. 65535 = Timed mode runs indefinitely. The timer is not used when 65535 is written to this register.
4x20496	PROG. INPUT TIME	R/W	1	65535	minutes	Set and read programmable input input current value, decreases when programmable input is controlling the unit.
4x21772	PROG. INPUT TIMER ENABLED	R/W	0	1		Enable or disable programmable input mode timer [0=timer disabled, 1= timer enabled]

## Avläsning av fläkthastighet

register	namn	R/RW	min	max	type	description
3x4353	FAN SPEED	R	0	100	%	Read current fan speed 0-100%, only available with % control
3x46003	CFi SUPPLY AIRFLOW	R	0	unit_max	flow	Read current supply airflow, only available CFi units
3x46004	CFi EXTRACT AIRFLOW	R	0	unit_max	flow	Read current extract airflow, only available CFi units

## Filter

register	name	R/RW	min	max	type	description
3x4620	REMAINING_TIME_FOR_FILTER	R	0	365	days	Read remaining time to filter change indication
4x20546	FILTER_CHANGED_DAY	R/W	1	31	days	Last filter change date
4x20547	FILTER_CHANGED_MONTH	R/W	1	12	months	Last filter change date
4x20548	FILTER_CHANGED_YEAR	R/W	0	99	years	Last filter change date

## Övriga register

register	name	R/RW	min	max	type	description
4x4611	DEFROSTING	R/W	0	1		Start defrosting manually [0 = no defrosting, 1 = Defrosting is on]
3x4616	HR CELL STATUS	R	0	3		Read HR cell status [0 = heat recovery, 1 = cool recovery, 2 = HR cell bypass, 3 =defrosting]
4x20549	TEMPERATURE CONTROL METHOD	R/W	0	3		Read or set supply air heating method [0 =supply air, 1 = extract air, 2 = cooling, 3 = airheating]
3x4359	RH_LEVEL	R	0	3		RH level (no sensor, low, med, high).
3x4360	CO2_LEVEL	R	0	3		CO2 level (no sensor, low, med, high)
3x4361	EXTR_FAN_SPEED	R	0	10000	RPM	Extract fan speed
3x4362	SUPP_FAN_SPEED	R	0	10000	RPM	Supply fan speed
3x4365	CUSTOM_SWITCH	R	0	1		Digital input 1 state (off on)
3x4366	DIGITAL_INPUT	R	0	1		Digital input 2 state (off on)
3x4367	ANALOG_CTRL_INPUT	R	0	100	%	Analog input control state
3x4368	MULTISENSOR_CO2	R	0	65535	12bit	CO2 concentration from multisensor
3x4369	MULTISENSOR_TEMP	R	0	65535	12bit	Tempearature from multisensor
3x4370	MULTISENSOR_RH	R	0	65535	12bit	Humidity from multisensor3x
3x4372	ANALOG_SENSOR_INPUT	R	0	65535	%RH	Internal %RH sensor 65535 = No sensor
3x4373	RH_SENSOR_0	R	0	65535	%RH	RH value from sensor 0
3x4374	RH_SENSOR_1	R	0	65535	%RH	RH value from sensor 1
3x4375	RH_SENSOR_2	R	0	65535	%RH	RH value from sensor 2
3x4376	RH_SENSOR_3	R	0	65535	%RH	RH value from sensor 3
3x4377	RH_SENSOR_4	R	0	65535	%RH	RH value from sensor 4
3x4378	RH_SENSOR_5	R	0	65535	%RH	RH value from sensor 5
3x4379	CO2_SENSOR_0	R	0	65535	PPM	CO2 value from sensor 0
3x4380	CO2_SENSOR_1	R	0	65535	PPM	CO2 value from sensor 1
3x4381	CO2_SENSOR_2	R	0	65535	PPM	CO2 value from sensor 2
3x4382	CO2_SENSOR_3	R	0	65535	PPM	CO2 value from sensor 3
3x4383	CO2_SENSOR_4	R	0	65535	PPM	CO2 value from sensor 4
3x4384	CO2_SENSOR_5	R	0	65535	PPM	CO2 value from sensor 5
3x4390	VOC_LEVEL	R	0	65535	PPM	VOC sensor highest value (not used locked to 1000)
3x4391	VOC_SENSOR_0	R	0	65535	PPM	VOC value from sensor 0
3x4392	VOC_SENSOR_1	R	0	65535	PPM	VOC value from sensor 1
3x4393	VOC_SENSOR_2	R	0	65535	PPM	VOC value from sensor 2
3x4394	VOC_SENSOR_3	R	0	65535	PPM	VOC value from sensor 3
4x4615	WEEKLY_TIMER_ENABLED	R/W	0	1		Weekly timer state (off on)
3x4617	TOTAL_UP_TIME_YEARS	R	0	65535	a	Total up time
3x4618	TOTAL_UP_TIME_HOURS	R	0	8760	h	Total up time
3x4619	CURRENT_UP_TIME_HOURS	R	0	65535	h	Current up time
4x4627	COMMAND	R/W	0	65535		Command variable
3x4628	MLV_STATE	R	0	1		"Earth heat" radiator state flag (off on)
4x4849	MINUTE	R/W	0	59	minutes	Minutes of the current time
4x4850	HOUR	R/W	0	23	hours	Hours of the current time
4x4851	DAY	R/W	1	31	days	Days of the current time
4x4852	MONTH	R/W	1	12	months	Months of the current date
4x4853	YEAR	R/W	0	99	years	Years of the current date
3x4854	WEEKDAY	R	1	7	weekday	Weekday (Mon Tue Wed ...)
3x8194	GW_ADDRESS_1	R	0	65535		Gateway address (0xAABB)
3x8195	GW_ADDRESS_2	R	0	65535		Gateway address (0xCCDD)
3x8196	MASK_ADDRESS_1	R	0	65535		Mask (0xAABB)
3x8197	MASK_ADDRESS_2	R	0	65535		Mask (0xCCDD)
4x8211	ETH_CLOUD_ENABLED	R/W	0	1		Outgoing connection to cloud (disabled enabled)
3x8212	IP_ADDRESS_1	R	0	65535		IP address first two bytes (0xAABB)
3x8213	IP_ADDRESS_1	R	0	65535		IP address last two bytes (0xCCDD)
4x20482	MODBUS_ADDRESS	R/W	1	247	8bit addr.	Modbus address on remote bus 1...247 (0xF7)
4x20483	MODBUS_BAUD_x100	R/W	96	1152		Baud * 100 Modbus speed on remote bus

register	name	R/RW	min	max	type	description
4x20484	MODBUS_FRAME	R/W	0	514	8bit pair	Modbus data frame; MSB parity ...
4x20517	RELAY_MODE	R/W	0	8	16bit value	Error relay mode (maintenance reminder error ...)
4x20518	DIGITAL_INPUT_1_MODE	R/W	0	8	16bit value	Digital input 1 mode (None custom home/away ...)
4x20519	DIGITAL_INPUT_2_MODE	R/W	0	8	16bit value	Digital input 2 mode (None custom home/away ...)
4x20520	ANALOG_INPUT_MODE	R/W	0	3	16bit value	Analog input mode (None Situational control ...)
4x20521	MLV_SUPPLY_LOWER_LIMIT	R/W	27815	29815	cK	MLV cooling lower limit for supply
4x20523	MLV_AUTO_MANUAL	R/W	0	1	16bit value	MLV control type (automatic manual)
4x20529	MLV_SUMMER_SETPOINT	R/W	28315	29815	cK	MLV summer setpoint
4x20530	MLV_MODES	R/W	0	2	16bit value	MLV Modes (heating and cooling heating cooling)
4x20531	MLV_WINTER_SETPOINT	R/W	26315	27815	cK	MLV winter setpoint
4x20537	FILTER_CHANGE_INTERVAL	R/W	30	365	days	Interval for filter change indicator (reload value)
4x20538	CELL_TYPE	R/W	0	2	16bit value	Heat recovery cell (aluminium plastic enthalpy)
4x20539	EXTRA_HEATER_TYPE	R/W	0	2	16bit value	Extra heater type (None Electric Water)
4x20540	POST_HEATER_TYPE	R/W	0	2	16bit value	Post heater type (None Electric Water)
4x20543	RH_LEVEL_MODE	R/W	0	1		Automatic level update Manual
4x20551	PARTIAL_BYPASS	R/W	0	2	16bit value	Partial bypass state (None, summer, always)
4x20552	BYPASS_LOCKED	R/W	0	1	16bit value	Bypass locked to winter position (open locked)
4x20553	OPT_TEMP_SENSOR_MODE	R/W	0	3	16bit value	Opt. Sensor mode (None, MLV, out, Airheater, MLV Supply)
4x20554	POST_HEATER_WINTER_SETPOINT	R/W	25315	30315	cK	Post heater winter limit temperature
4x20555	DEWPOINT_LIMIT_IN_USE	R/W	0	1	16bit value	Use dew point limit in supply air setting (not in use)
4x21764	ACCESS_LEVEL	R/W	0	2		Access level (free limited very limited)
4x21765	PARENTAL_CTRL_ENABLED	R/W	0	1		Parental control state (off, on)
4x21768	SUMMER_TIME_AUTO_ENAB	R/W	0	1		Automatic summer time (off, on)
4x21769	12_HOUR_CLOCK_ENABLED	R/W	0	1		12 hour clock (off on)
4x40961	SCHEDULE_MONDAY_00	R/W	0	3		State at 00:00 on Monday [None, home, away, boost]
4x40962	SCHEDULE_MONDAY_01	R/W	0	3		State at 01:00 on Monday [None, home, away, boost]
4x40963	SCHEDULE_MONDAY_02	R/W	0	3		State at 02:00 on Monday [None, home, away, boost]
4x40964	SCHEDULE_MONDAY_03	R/W	0	3		State at 03:00 on Monday [None, home, away, boost]
4x40965	SCHEDULE_MONDAY_04	R/W	0	3		State at 04:00 on Monday [None, home, away, boost]
4x40966	SCHEDULE_MONDAY_05	R/W	0	3		State at 05:00 on Monday [None, home, away, boost]
4x40967	SCHEDULE_MONDAY_06	R/W	0	3		State at 06:00 on Monday [None, home, away, boost]
4x40968	SCHEDULE_MONDAY_07	R/W	0	3		State at 07:00 on Monday [None, home, away, boost]
4x40969	SCHEDULE_MONDAY_08	R/W	0	3		State at 08:00 on Monday [None, home, away, boost]
4x40970	SCHEDULE_MONDAY_09	R/W	0	3		State at 09:00 on Monday [None, home, away, boost]
4x40971	SCHEDULE_MONDAY_10	R/W	0	3		State at 10:00 on Monday [None, home, away, boost]
4x40972	SCHEDULE_MONDAY_11	R/W	0	3		State at 11:00 on Monday [None, home, away, boost]
4x40973	SCHEDULE_MONDAY_12	R/W	0	3		State at 12:00 on Monday [None, home, away, boost]
4x40974	SCHEDULE_MONDAY_13	R/W	0	3		State at 13:00 on Monday [None, home, away, boost]
4x40975	SCHEDULE_MONDAY_14	R/W	0	3		State at 14:00 on Monday [None, home, away, boost]
4x40976	SCHEDULE_MONDAY_15	R/W	0	3		State at 15:00 on Monday [None, home, away, boost]
4x40977	SCHEDULE_MONDAY_16	R/W	0	3		State at 16:00 on Monday [None, home, away, boost]
4x40978	SCHEDULE_MONDAY_17	R/W	0	3		State at 17:00 on Monday [None, home, away, boost]
4x40979	SCHEDULE_MONDAY_18	R/W	0	3		State at 18:00 on Monday [None, home, away, boost]
4x40980	SCHEDULE_MONDAY_19	R/W	0	3		State at 19:00 on Monday [None, home, away, boost]
4x40981	SCHEDULE_MONDAY_20	R/W	0	3		State at 20:00 on Monday [None, home, away, boost]
4x40982	SCHEDULE_MONDAY_21	R/W	0	3		State at 21:00 on Monday [None, home, away, boost]
4x40983	SCHEDULE_MONDAY_22	R/W	0	3		State at 21200 on Monday [None, home, away, boost]
4x40984	SCHEDULE_MONDAY_23	R/W	0	3		State at 23:00 on Monday [None, home, away, boost]
4x40985	SCHEDULE_TUESDAY_00	R/W	0	3		State at 00:00 on Tuesday [None, home, away, boost]

register	name	R/RW	min	max	type	description
4x40986	SCHEDULE_TUESDAY_01	R/W	0	3		State at 01:00 on Tuesday [None, home, away, boost]
4x40987	SCHEDULE_TUESDAY_02	R/W	0	3		State at 02:00 on Tuesday [None, home, away, boost]
4x40988	SCHEDULE_TUESDAY_03	R/W	0	3		State at 03:00 on Tuesday [None, home, away, boost]
4x40989	SCHEDULE_TUESDAY_04	R/W	0	3		State at 04:00 on Tuesday [None, home, away, boost]
4x40990	SCHEDULE_TUESDAY_05	R/W	0	3		State at 05:00 on Tuesday [None, home, away, boost]
4x40991	SCHEDULE_TUESDAY_06	R/W	0	3		State at 06:00 on Tuesday [None, home, away, boost]
4x40992	SCHEDULE_TUESDAY_07	R/W	0	3		State at 07:00 on Tuesday [None, home, away, boost]
4x40993	SCHEDULE_TUESDAY_08	R/W	0	3		State at 08:00 on Tuesday [None, home, away, boost]
4x40994	SCHEDULE_TUESDAY_09	R/W	0	3		State at 09:00 on Tuesday [None, home, away, boost]
4x40995	SCHEDULE_TUESDAY_10	R/W	0	3		State at 10:00 on Tuesday [None, home, away, boost]
4x40996	SCHEDULE_TUESDAY_11	R/W	0	3		State at 11:00 on Tuesday [None, home, away, boost]
4x40997	SCHEDULE_TUESDAY_12	R/W	0	3		State at 12:00 on Tuesday [None, home, away, boost]
4x40998	SCHEDULE_TUESDAY_13	R/W	0	3		State at 13:00 on Tuesday [None, home, away, boost]
4x40999	SCHEDULE_TUESDAY_14	R/W	0	3		State at 14:00 on Tuesday [None, home, away, boost]
4x41000	SCHEDULE_TUESDAY_15	R/W	0	3		State at 15:00 on Tuesday [None, home, away, boost]
4x41001	SCHEDULE_TUESDAY_16	R/W	0	3		State at 16:00 on Tuesday [None, home, away, boost]
4x41002	SCHEDULE_TUESDAY_17	R/W	0	3		State at 17:00 on Tuesday [None, home, away, boost]
4x41003	SCHEDULE_TUESDAY_18	R/W	0	3		State at 18:00 on Tuesday [None, home, away, boost]
4x41004	SCHEDULE_TUESDAY_19	R/W	0	3		State at 19:00 on Tuesday [None, home, away, boost]
4x41005	SCHEDULE_TUESDAY_20	R/W	0	3		State at 20:00 on Tuesday [None, home, away, boost]
4x41006	SCHEDULE_TUESDAY_21	R/W	0	3		State at 21:00 on Tuesday [None, home, away, boost]
4x41007	SCHEDULE_TUESDAY_22	R/W	0	3		State at 22:00 on Tuesday [None, home, away, boost]
4x41008	SCHEDULE_TUESDAY_23	R/W	0	3		State at 23:00 on Tuesday [None, home, away, boost]
4x41009	SCHEDULE_WEDNESDAY_00	R/W	0	3		State at 00:00 on Wednesday [None, home, away, boost]
4x41010	SCHEDULE_WEDNESDAY_01	R/W	0	3		State at 01:00 on Wednesday [None, home, away, boost]
4x41011	SCHEDULE_WEDNESDAY_02	R/W	0	3		State at 02:00 on Wednesday [None, home, away, boost]
4x41012	SCHEDULE_WEDNESDAY_03	R/W	0	3		State at 03:00 on Wednesday [None, home, away, boost]
4x41013	SCHEDULE_WEDNESDAY_04	R/W	0	3		State at 04:00 on Wednesday [None, home, away, boost]
4x41014	SCHEDULE_WEDNESDAY_05	R/W	0	3		State at 05:00 on Wednesday [None, home, away, boost]
4x41015	SCHEDULE_WEDNESDAY_06	R/W	0	3		State at 06:00 on Wednesday [None, home, away, boost]
4x41016	SCHEDULE_WEDNESDAY_07	R/W	0	3		State at 07:00 on Wednesday [None, home, away, boost]
4x41017	SCHEDULE_WEDNESDAY_08	R/W	0	3		State at 08:00 on Wednesday [None, home, away, boost]
4x41018	SCHEDULE_WEDNESDAY_09	R/W	0	3		State at 09:00 on Wednesday [None, home, away, boost]
4x41019	SCHEDULE_WEDNESDAY_10	R/W	0	3		State at 10:00 on Wednesday [None, home, away, boost]
4x41020	SCHEDULE_WEDNESDAY_11	R/W	0	3		State at 11:00 on Wednesday [None, home, away, boost]
4x41021	SCHEDULE_WEDNESDAY_12	R/W	0	3		State at 12:00 on Wednesday [None, home, away, boost]
4x41022	SCHEDULE_WEDNESDAY_13	R/W	0	3		State at 13:00 on Wednesday [None, home, away, boost]
4x41023	SCHEDULE_WEDNESDAY_14	R/W	0	3		State at 14:00 on Wednesday [None, home, away, boost]
4x41024	SCHEDULE_WEDNESDAY_15	R/W	0	3		State at 15:00 on Wednesday [None, home, away, boost]
4x41025	SCHEDULE_WEDNESDAY_16	R/W	0	3		State at 16:00 on Wednesday [None, home, away, boost]
4x41026	SCHEDULE_WEDNESDAY_17	R/W	0	3		State at 17:00 on Wednesday [None, home, away, boost]
4x41027	SCHEDULE_WEDNESDAY_18	R/W	0	3		State at 18:00 on Wednesday [None, home, away, boost]
4x41028	SCHEDULE_WEDNESDAY_19	R/W	0	3		State at 19:00 on Wednesday [None, home, away, boost]
4x41029	SCHEDULE_WEDNESDAY_20	R/W	0	3		State at 20:00 on Wednesday [None, home, away, boost]
4x41030	SCHEDULE_WEDNESDAY_21	R/W	0	3		State at 21:00 on Wednesday [None, home, away, boost]
4x41031	SCHEDULE_WEDNESDAY_22	R/W	0	3		State at 22:00 on Wednesday [None, home, away, boost]
4x41032	SCHEDULE_WEDNESDAY_23	R/W	0	3		State at 23:00 on Wednesday [None, home, away, boost]
4x41033	SCHEDULE_THURSDAY_00	R/W	0	3		State at 00:00 on Thursday [None, home, away, boost]
4x41034	SCHEDULE_THURSDAY_01	R/W	0	3		State at 01:00 on Thursday [None, home, away, boost]

register	name	R/RW	min	max	type	description
4x41035	SCHEDULE_THURSDAY_02	R/W	0	3		State at 02:00 on Thursday [None, home, away, boost]
4x41036	SCHEDULE_THURSDAY_03	R/W	0	3		State at 03:00 on Thursday [None, home, away, boost]
4x41037	SCHEDULE_THURSDAY_04	R/W	0	3		State at 04:00 on Thursday [None, home, away, boost]
4x41038	SCHEDULE_THURSDAY_05	R/W	0	3		State at 05:00 on Thursday [None, home, away, boost]
4x41039	SCHEDULE_THURSDAY_06	R/W	0	3		State at 06:00 on Thursday [None, home, away, boost]
4x41040	SCHEDULE_THURSDAY_07	R/W	0	3		State at 07:00 on Thursday [None, home, away, boost]
4x41041	SCHEDULE_THURSDAY_08	R/W	0	3		State at 08:00 on Thursday [None, home, away, boost]
4x41042	SCHEDULE_THURSDAY_09	R/W	0	3		State at 09:00 on Thursday [None, home, away, boost]
4x41043	SCHEDULE_THURSDAY_10	R/W	0	3		State at 10:00 on Thursday [None, home, away, boost]
4x41044	SCHEDULE_THURSDAY_11	R/W	0	3		State at 11:00 on Thursday [None, home, away, boost]
4x41045	SCHEDULE_THURSDAY_12	R/W	0	3		State at 12:00 on Thursday [None, home, away, boost]
4x41046	SCHEDULE_THURSDAY_13	R/W	0	3		State at 13:00 on Thursday [None, home, away, boost]
4x41047	SCHEDULE_THURSDAY_14	R/W	0	3		State at 14:00 on Thursday [None, home, away, boost]
4x41048	SCHEDULE_THURSDAY_15	R/W	0	3		State at 15:00 on Thursday [None, home, away, boost]
4x41049	SCHEDULE_THURSDAY_16	R/W	0	3		State at 16:00 on Thursday [None, home, away, boost]
4x41050	SCHEDULE_THURSDAY_17	R/W	0	3		State at 17:00 on Thursday [None, home, away, boost]
4x41051	SCHEDULE_THURSDAY_18	R/W	0	3		State at 18:00 on Thursday [None, home, away, boost]
4x41052	SCHEDULE_THURSDAY_19	R/W	0	3		State at 19:00 on Thursday [None, home, away, boost]
4x41053	SCHEDULE_THURSDAY_20	R/W	0	3		State at 20:00 on Thursday [None, home, away, boost]
4x41054	SCHEDULE_THURSDAY_21	R/W	0	3		State at 21:00 on Thursday [None, home, away, boost]
4x41055	SCHEDULE_THURSDAY_22	R/W	0	3		State at 22:00 on Thursday [None, home, away, boost]
4x41056	SCHEDULE_THURSDAY_23	R/W	0	3		State at 23:00 on Thursday [None, home, away, boost]
4x41057	SCHEDULE_FRIDAY_00	R/W	0	3		State at 00:00 on Friday [None, home, away, boost]
4x41058	SCHEDULE_FRIDAY_01	R/W	0	3		State at 01:00 on Friday [None, home, away, boost]
4x41059	SCHEDULE_FRIDAY_02	R/W	0	3		State at 02:00 on Friday [None, home, away, boost]
4x41060	SCHEDULE_FRIDAY_03	R/W	0	3		State at 03:00 on Friday [None, home, away, boost]
4x41061	SCHEDULE_FRIDAY_04	R/W	0	3		State at 04:00 on Friday [None, home, away, boost]
4x41062	SCHEDULE_FRIDAY_05	R/W	0	3		State at 05:00 on Friday [None, home, away, boost]
4x41063	SCHEDULE_FRIDAY_06	R/W	0	3		State at 06:00 on Friday [None, home, away, boost]
4x41064	SCHEDULE_FRIDAY_07	R/W	0	3		State at 07:00 on Friday [None, home, away, boost]
4x41065	SCHEDULE_FRIDAY_08	R/W	0	3		State at 08:00 on Friday [None, home, away, boost]
4x41066	SCHEDULE_FRIDAY_09	R/W	0	3		State at 09:00 on Friday [None, home, away, boost]
4x41067	SCHEDULE_FRIDAY_10	R/W	0	3		State at 10:00 on Friday [None, home, away, boost]
4x41068	SCHEDULE_FRIDAY_11	R/W	0	3		State at 11:00 on Friday [None, home, away, boost]
4x41069	SCHEDULE_FRIDAY_12	R/W	0	3		State at 12:00 on Friday [None, home, away, boost]
4x41070	SCHEDULE_FRIDAY_13	R/W	0	3		State at 13:00 on Friday [None, home, away, boost]
4x41071	SCHEDULE_FRIDAY_14	R/W	0	3		State at 14:00 on Friday [None, home, away, boost]
4x41072	SCHEDULE_FRIDAY_15	R/W	0	3		State at 15:00 on Friday [None, home, away, boost]
4x41073	SCHEDULE_FRIDAY_16	R/W	0	3		State at 16:00 on Friday [None, home, away, boost]
4x41074	SCHEDULE_FRIDAY_17	R/W	0	3		State at 17:00 on Friday [None, home, away, boost]
4x41075	SCHEDULE_FRIDAY_18	R/W	0	3		State at 18:00 on Friday [None, home, away, boost]
4x41076	SCHEDULE_FRIDAY_19	R/W	0	3		State at 19:00 on Friday [None, home, away, boost]
4x41077	SCHEDULE_FRIDAY_20	R/W	0	3		State at 20:00 on Friday [None, home, away, boost]
4x41078	SCHEDULE_FRIDAY_21	R/W	0	3		State at 21:00 on Friday [None, home, away, boost]
4x41079	SCHEDULE_FRIDAY_22	R/W	0	3		State at 22:00 on Friday [None, home, away, boost]
4x41080	SCHEDULE_FRIDAY_23	R/W	0	3		State at 23:00 on Friday [None, home, away, boost]
4x41081	SCHEDULE_SATURDAY_00	R/W	0	3		State at 00:00 on Saturday [None, home, away, boost]
4x41082	SCHEDULE_SATURDAY_01	R/W	0	3		State at 01:00 on Saturday [None, home, away, boost]
4x41083	SCHEDULE_SATURDAY_02	R/W	0	3		State at 02:00 on Saturday [None, home, away, boost]

register	name	R/RW	min	max	type	description
4x41084	SCHEDULE_SATURDAY_03	R/W	0	3		State at 03:00 on Saturday [None, home, away, boost]
4x41085	SCHEDULE_SATURDAY_04	R/W	0	3		State at 04:00 on Saturday [None, home, away, boost]
4x41086	SCHEDULE_SATURDAY_05	R/W	0	3		State at 05:00 on Saturday [None, home, away, boost]
4x41087	SCHEDULE_SATURDAY_06	R/W	0	3		State at 06:00 on Saturday [None, home, away, boost]
4x41088	SCHEDULE_SATURDAY_07	R/W	0	3		State at 07:00 on Saturday [None, home, away, boost]
4x41089	SCHEDULE_SATURDAY_08	R/W	0	3		State at 08:00 on Saturday [None, home, away, boost]
4x41090	SCHEDULE_SATURDAY_09	R/W	0	3		State at 09:00 on Saturday [None, home, away, boost]
4x41091	SCHEDULE_SATURDAY_10	R/W	0	3		State at 10:00 on Saturday [None, home, away, boost]
4x41092	SCHEDULE_SATURDAY_11	R/W	0	3		State at 11:00 on Saturday [None, home, away, boost]
4x41093	SCHEDULE_SATURDAY_12	R/W	0	3		State at 12:00 on Saturday [None, home, away, boost]
4x41094	SCHEDULE_SATURDAY_13	R/W	0	3		State at 13:00 on Saturday [None, home, away, boost]
4x41095	SCHEDULE_SATURDAY_14	R/W	0	3		State at 14:00 on Saturday [None, home, away, boost]
4x41096	SCHEDULE_SATURDAY_15	R/RW	0	3		State at 15:00 on Saturday [None, home, away, boost]
4x41097	SCHEDULE_SATURDAY_16	R/W	0	3		State at 16:00 on Saturday [None, home, away, boost]
4x41098	SCHEDULE_SATURDAY_17	R/W	0	3		State at 17:00 on Saturday [None, home, away, boost]
4x41099	SCHEDULE_SATURDAY_18	R/W	0	3		State at 18:00 on Saturday [None, home, away, boost]
4x41100	SCHEDULE_SATURDAY_19	R/W	0	3		State at 19:00 on Saturday [None, home, away, boost]
4x41101	SCHEDULE_SATURDAY_20	R/W	0	3		State at 20:00 on Saturday [None, home, away, boost]
4x41102	SCHEDULE_SATURDAY_21	R/W	0	3		State at 21:00 on Saturday [None, home, away, boost]
4x41103	SCHEDULE_SATURDAY_22	R/W	0	3		State at 22:00 on Saturday [None, home, away, boost]
4x41104	SCHEDULE_SATURDAY_23	R/W	0	3		State at 23:00 on Saturday [None, home, away, boost]
4x41105	SCHEDULE_SUNDAY_00	R/W	0	3		State at 00:00 on Sunday [None, home, away, boost]
4x41106	SCHEDULE_SUNDAY_01	R/W	0	3		State at 01:00 on Sunday [None, home, away, boost]
4x41107	SCHEDULE_SUNDAY_02	R/W	0	3		State at 02:00 on Sunday [None, home, away, boost]
4x41108	SCHEDULE_SUNDAY_03	R/W	0	3		State at 03:00 on Sunday [None, home, away, boost]
4x41109	SCHEDULE_SUNDAY_04	R/W	0	3		State at 04:00 on Sunday [None, home, away, boost]
4x41110	SCHEDULE_SUNDAY_05	R/W	0	3		State at 05:00 on Sunday [None, home, away, boost]
4x41111	SCHEDULE_SUNDAY_06	R/W	0	3		State at 06:00 on Sunday [None, home, away, boost]
4x41112	SCHEDULE_SUNDAY_07	R/W	0	3		State at 07:00 on Sunday [None, home, away, boost]
4x41113	SCHEDULE_SUNDAY_08	R/W	0	3		State at 08:00 on Sunday [None, home, away, boost]
4x41114	SCHEDULE_SUNDAY_09	R/W	0	3		State at 09:00 on Sunday [None, home, away, boost]
4x41115	SCHEDULE_SUNDAY_10	R/W	0	3		State at 10:00 on Sunday [None, home, away, boost]
4x41116	SCHEDULE_SUNDAY_11	R/W	0	3		State at 11:00 on Sunday [None, home, away, boost]
4x41117	SCHEDULE_SUNDAY_12	R/W	0	3		State at 12:00 on Sunday [None, home, away, boost]
4x41118	SCHEDULE_SUNDAY_13	R/W	0	3		State at 13:00 on Sunday [None, home, away, boost]
4x41119	SCHEDULE_SUNDAY_14	R/W	0	3		State at 14:00 on Sunday [None, home, away, boost]
4x41120	SCHEDULE_SUNDAY_15	R/W	0	3		State at 15:00 on Sunday [None, home, away, boost]
4x41121	SCHEDULE_SUNDAY_16	R/W	0	3		State at 16:00 on Sunday [None, home, away, boost]
4x41122	SCHEDULE_SUNDAY_17	R/W	0	3		State at 17:00 on Sunday [None, home, away, boost]
4x41123	SCHEDULE_SUNDAY_18	R/W	0	3		State at 18:00 on Sunday [None, home, away, boost]
4x41124	SCHEDULE_SUNDAY_19	R/W	0	3		State at 19:00 on Sunday [None, home, away, boost]
4x41125	SCHEDULE_SUNDAY_20	R/W	0	3		State at 20:00 on Sunday [None, home, away, boost]
4x41126	SCHEDULE_SUNDAY_21	R/W	0	3		State at 21:00 on Sunday [None, home, away, boost]
4x41127	SCHEDULE_SUNDAY_22	R/W	0	3		State at 22:00 on Sunday [None, home, away, boost]
4x41128	SCHEDULE_SUNDAY_23	R/W	0	3		State at 23:00 on Sunday [None, home, away, boost]

**VALLOX**

[www.vallox.com](http://www.vallox.com)

Vallox Oy | Myllykyläntie 9-11 | 32200 LOIMAA | FINLAND

D11408/07.08.2025