

# VALLOX

**Model**

MyVallox 125 CFi

**Document**

D11778

**Type**

3766

**Valid from**

01.05.2026

**Updated**

18.06.2026

**MyVALLOX**  
125 CFi

User manual

---

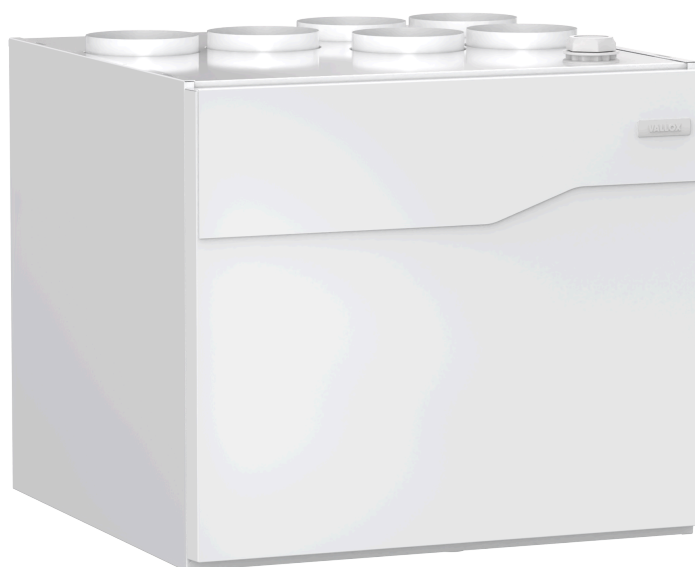

---

# Contents

<b>1. Introduction</b> .....	<b>3</b>
<b>1.1. Safety</b> .....	<b>3</b>
1.1.1. Safety signs used in the instructions .....	4
<b>1.2. Intended use</b> .....	<b>5</b>
<b>1.3. Warnings</b> .....	<b>6</b>
<b>1.4. System description</b> .....	<b>7</b>
<b>1.5. Guarantee</b> .....	<b>7</b>
<b>1.6. Disposal of the ventilation unit</b> .....	<b>8</b>
<b>1.7. Main parts</b> .....	<b>9</b>
<b>2. Installation</b> .....	<b>10</b>
<b>2.1. Mounting on the wall</b> .....	<b>11</b>
<b>2.2. Mounting the ventilation unit to the ceiling</b> .....	<b>12</b>
<b>2.3. Removal of condensing water</b> .....	<b>14</b>
<b>3. Ventilation unit control options</b> .....	<b>16</b>
<b>3.1. Connecting the ventilation unit to the cloud service</b> .....	<b>16</b>
<b>3.2. Connecting the ventilation unit to a computer</b> .....	<b>17</b>
<b>3.3. Registering the ventilation unit in the MyVallox Cloud service</b> .....	<b>18</b>
<b>4. Maintenance</b> .....	<b>22</b>
<b>4.1. Replacing the filters</b> .....	<b>23</b>
<b>4.2. Cleaning the heat recovery cell</b> .....	<b>24</b>
<b>4.3. Cleaning the fans</b> .....	<b>26</b>
<b>4.4. Condensing water</b> .....	<b>30</b>
<b>4.5. Updating the unit software (MyVallox Control)</b> .....	<b>30</b>
<b>4.6. Troubleshooting</b> .....	<b>32</b>
<b>5. Technical specifications</b> .....	<b>33</b>
<b>5.1. Supply/extract air volumes and input powers</b> .....	<b>34</b>
<b>5.2. Sound values</b> .....	<b>35</b>
<b>5.3. Internal electrical connection</b> .....	<b>36</b>

---

<b>5.4.</b> External electrical connection.....	<b>38</b>
<b>5.5.</b> External electrical connection for controlling the MLV duct radiator.....	<b>40</b>
<b>5.6.</b> Duct radiator operation.....	<b>41</b>
<b>5.7.</b> Dimensions and duct outlets .....	<b>44</b>
<b>6. Exploded view and list of spare parts .....</b>	<b>49</b>
<b>7. Declaration of Conformity.....</b>	<b>51</b>

---

# 1. INTRODUCTION

Thank you for choosing a Vallox product. For optimal performance, read the instructions carefully before installation, operation, or maintenance.

## 1.1. Safety

Safe and appropriate handling requires knowledge of the basic safety regulations, and of the intended use of the ventilation system. Read this manual before operating the ventilation unit. Retain the manual for later reference. If you lose the manual, it can be downloaded from our website.

These instructions contain all the information needed for the safe operation of the unit. All persons who install, operate, and maintain the ventilation unit must follow the provided instructions. Furthermore, all local accident prevention regulations must be observed.

### Installation

Installation and setup should be carried out only by qualified experts. Electrical installations and connections must be carried out only by an electrician and in compliance with local regulations

**!** **NOTE:** For further information, go to <https://www.vallox.com>

---

## 1.1.1. Safety signs used in the instructions

 **DANGER:**

Indicates a hazard that will result in death or serious injury if not avoided.

 **WARNING:**

Indicates a hazard that can result in death or serious injury if not avoided.

 **CAUTION:**

Indicates a hazard that can result in minor or moderate injury if not avoided.

 **IMPORTANT:**

Indicates a hazard that can result in damage to property or loss of data if not avoided.

 **NOTE:**

Indicates essential information about the product.

**TIP:**

Provides additional information about the use of the product and its benefits.

---

## 1.2. Intended use

All Vallox ventilation units have been designed to provide appropriate and continuous ventilation so as to present no threat to health and to maintain structures in good condition.

**⚠ WARNING:**

Ensure that the fireplace air intake is sufficient. Operating certain kitchen range hood, central vacuum cleaner and ventilation unit functions can create underpressure in the indoor air. Combustion gases can then be released from the fireplace into the indoor air.

The following can create underpressure indoors:

- Kitchen range hood or central vacuum cleaner are in operation while there is a fire burning in the fireplace
- The supply air fan is stopped during the defrosting function of the ventilation unit
- The boosted defrosting function of the ventilation unit is being used

Underpressure can prevent fireplace air intake, and combustion gases can then be released into the indoor air.

**! IMPORTANT:** In order to ensure that the indoor air presents no harm to health and remains optimal also for the structures of the building, ventilation must be kept on without disruptions. It is recommended that ventilation be left turned on during long holidays also. This keeps the indoor air fresh and prevents humidity from condensing in the ventilation ducts and structures. It also reduces the risk of moisture damage.

**! IMPORTANT:**

Prolonged overpressure can result in damage to the structures of the building.

---

## 1.3. Warnings

 **WARNING:** The unit is not intended for use by children under 8 or by persons with reduced sensory, physical or mental capabilities, or whose lack of knowledge and experience do not ensure safe operation of the unit. Such persons can use the unit under supervision, or by following the instructions of someone who is responsible for their safety. Children must be supervised and not be allowed to play with the device.

- The ventilation unit is very heavy.
- The door of the ventilation unit is heavy.
- Water must at all times be kept out of the electrical system.
- The timer function of the Custom mode can only be turned off when the external fireplace switch has a timer.
- The fan settings must be completed by a qualified specialist in accordance with the ventilation plan. If you edit the settings, ensure that they comply with the ventilation plan.
- The safety switch automatically turns off the power when the door of the ventilation unit is opened in connection with maintenance measures. **Always disconnect the ventilation unit from the mains** before starting maintenance.
- If the heating resistor needs to be removed from the unit in connection with maintenance measures, ensure that the relay is not hot before pulling it out of the unit.
- Connect the cables so that they do not touch the resistor.

## 1.4. System description

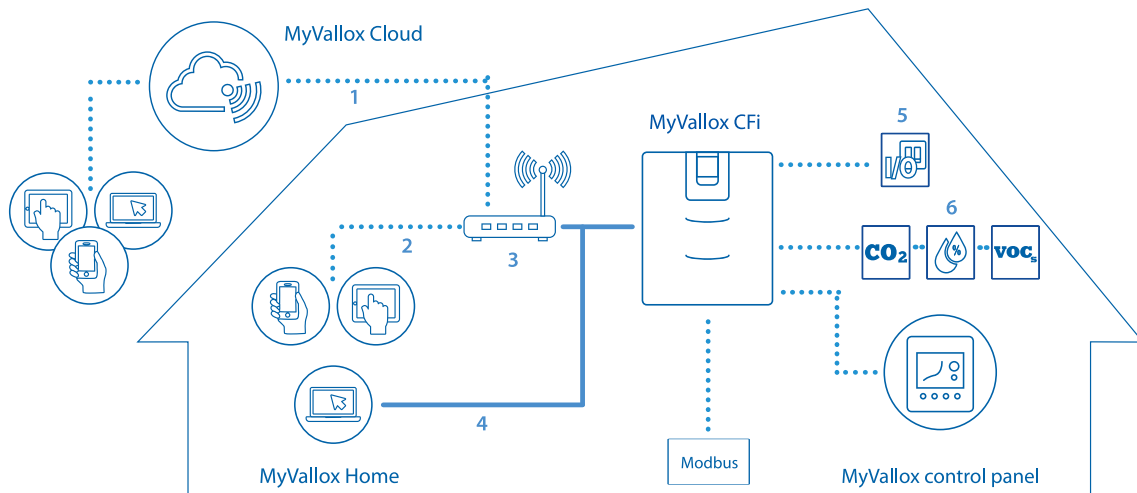

- 1 Internet
- 2 WLAN
- 3 Router
- 4 WLAN/LAN
- 5 Additional switch
- 6 Sensors

## 1.5. Guarantee

The guarantee and liability exclude damage resulting from:

- Inappropriate use of the ventilation unit or the control panel
- Incorrect or inappropriate installation, setup, or use
- Failure to follow instructions regarding transport, installation, operation, or maintenance
- Structural or electronic modifications or changes made to the software

---

## 1.6. Disposal of the ventilation unit

Do not dispose of electronic devices with household waste. Follow local laws and regulations on safe and ecological disposal of the product.

See the MyVallox ventilation unit recycling instructions at: [https://res.cloudinary.com/vallox/image/upload/v1704800151/FileStock/ValidManuals/Recycling\\_Instructions\\_Vallox\\_Ventilation\\_units.pdf](https://res.cloudinary.com/vallox/image/upload/v1704800151/FileStock/ValidManuals/Recycling_Instructions_Vallox_Ventilation_units.pdf).

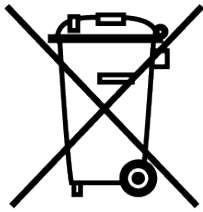

## 1.7. Main parts

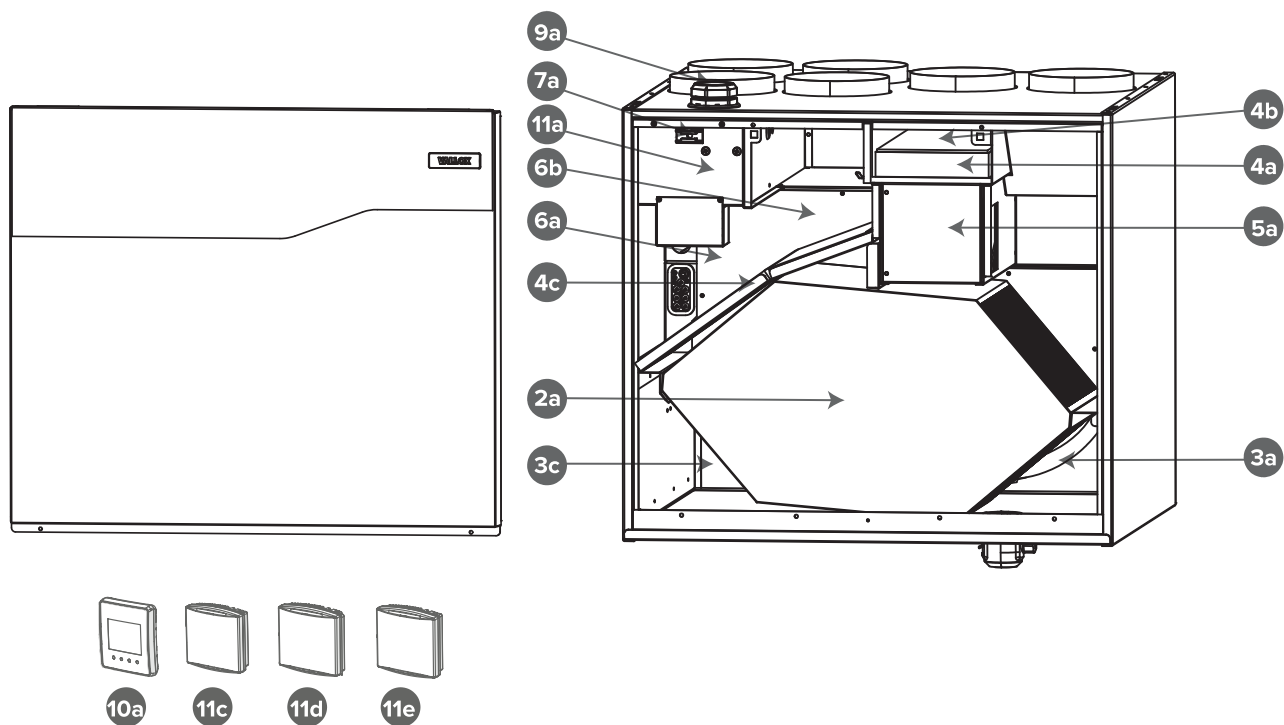

The figure shows the Vallox R model. In the L model, the parts are mirrored.

No.	Part	No.	Part
2a	Heat recovery cell	6b	Additional heating resistor
3a	Extract air fan	7a	Safety switch
3c	Supply air fan	9a	Ceiling bushing for electric wires
4a	Fine filter for supply air	10a	Control panel
4b	Coarse filter for supply air	11a	Internal carbon dioxide and humidity sensor
4c	Coarse filter for extract air	11c	Carbon dioxide sensor (optional)
5a	Bypass damper of the HR cell	11d	Humidity sensor (optional)
6a	Post-heating resistor	11e	VOC sensor (optional)

---

## 2. INSTALLATION

This chapter describes the installation of the Vallox ventilation unit.

Only a qualified technician is allowed to install and set up the unit. Electrical installation and connection work must be carried out by an electrician in line with local regulations.

Check the package contents before installation and make sure that all parts are in good condition. Store the product in a dry place (indoors).

Check the dimensions and weight of the product from the technical specification of the unit.

The ventilation unit must be installed in a dry place where the temperature does not drop below +10°C. When installed without its enclosure, the unit must be placed in a place where its running noise is not bothersome; for example, a storage room, utility room or a false ceiling.

It is normal for frost and ice to accumulate inside the ventilation unit when it is cold. This does not require any action from the user.

If the relative humidity of the ambient air is high and the outdoor temperature is very low, moisture may condense on the unit surface. This does not require any action from the user. The possibility of condensation should always be taken into account when selecting the furnishings and fixtures to be placed close to the unit.

Avoid mounting the ventilation unit to a hollow partition wall or a bedroom wall, or prevent the conduction of noise through the wall.

**! NOTE:**

The whole length of the outdoor air duct to the unit and the exhaust air duct from the unit must be insulated using closed-cell insulation. Closed-cell insulation is needed for the duct component that runs through warm spaces.

**! NOTE:**

The ventilation unit must be installed so that it can be connected to a LAN cable. The LAN cable must be able to be connected to a router.

## 2.1. Mounting on the wall

**! NOTE:**

Avoid mounting the ventilation unit to a hollow partition wall or a bedroom wall, or prevent the conduction of noise through the wall.

The minimum distance between the unit roof and the ceiling surface is 30 mm. Please note that the unit sits 10 mm higher than the final height when mounted by using a wall bracket.

**! NOTE:**

A space of at least 500 mm must be left in front of the unit for maintenance purposes.

**! NOTE:**

Install the ventilation unit in a place where the temperature does not drop below +10°C.

Mount the ventilation unit to the wall by using a wall mounting plate. Follow the images below. Make sure the unit is level after installation.

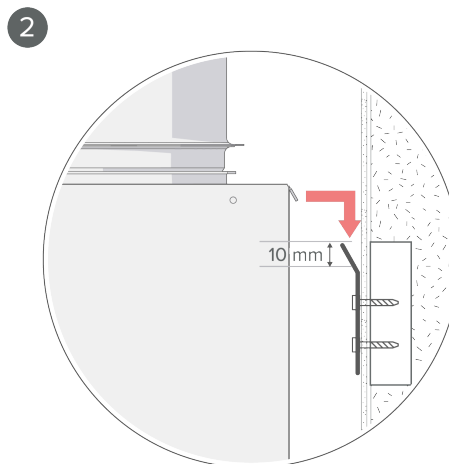
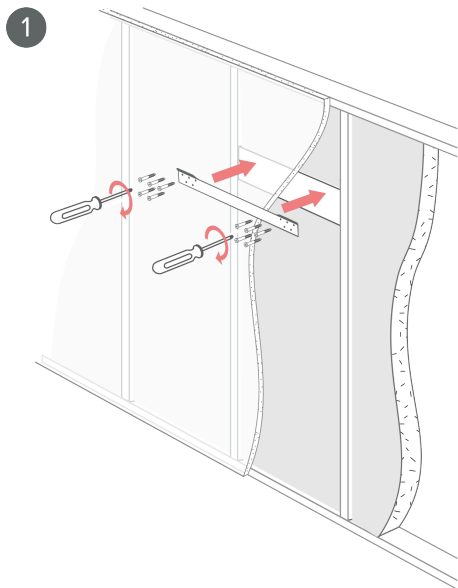

## 2.2. Mounting the ventilation unit to the ceiling

MyVallox 125 CFi units (excluding model B) can be equipped with an optional ceiling mounting plate.

**! NOTE:** The ventilation unit is very heavy. Do not perform this procedure alone. Use appropriate lifting equipment, where necessary.

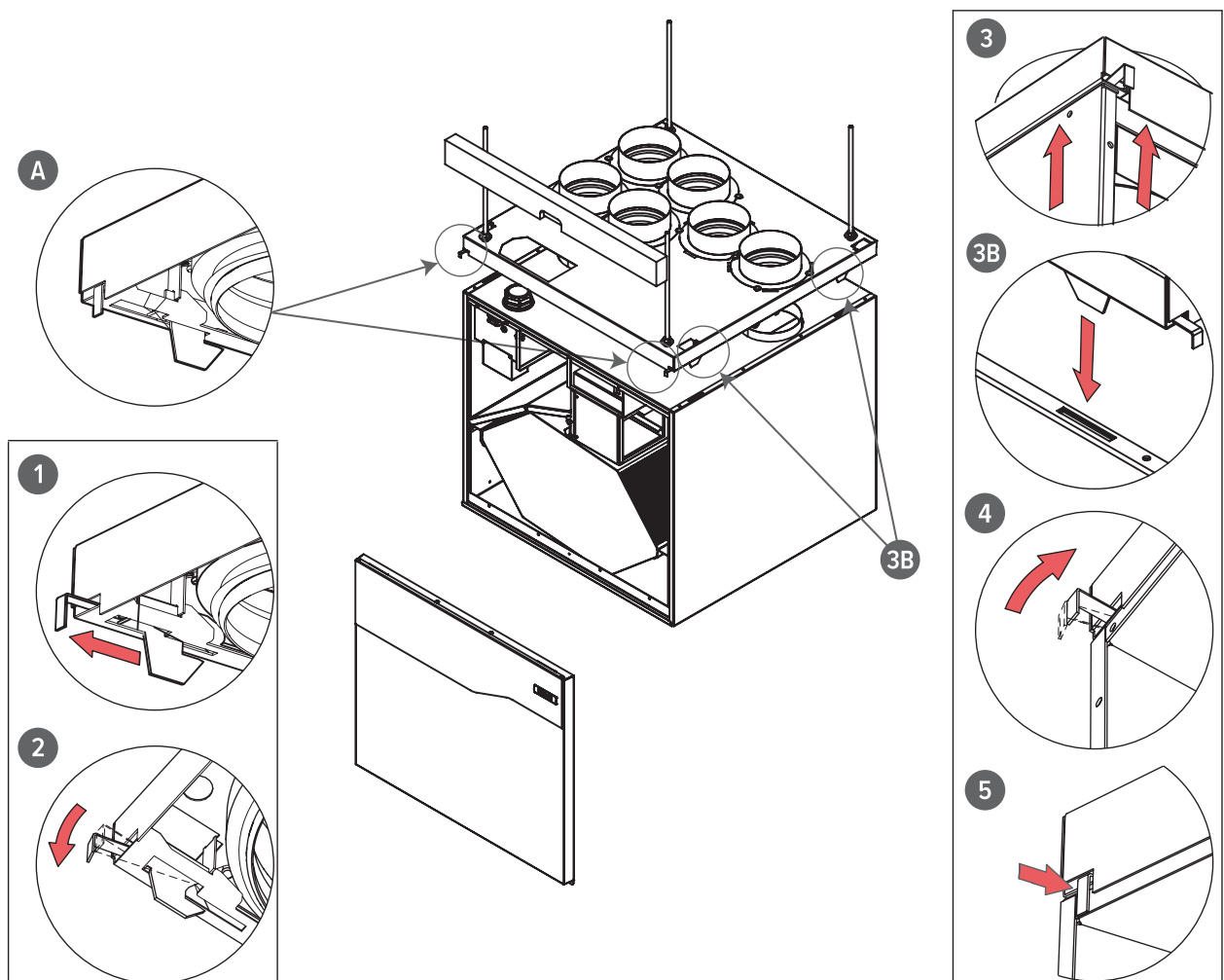

1. Fasten the M8 thread bars on the rafter frames or other frame structure and fasten the nuts onto the bars.
2. Lift the ceiling mounting plate in place.
3. Push a rubber damper and a washer to each thread bar.

4. Adjust the nuts so that the ceiling mounting plate is level.

**! NOTE:** The end of the thread bar must be 5 mm or less below the fastening nut. Do not fasten the ceiling mounting plate too tight to the ceiling. There must be nuts above the ceiling mounting plate to prevent the plate from lifting up when the unit is being mounted. Check that the sliding bars move and return to their original position by turning the operating levers **(A)** to the open position and then back to the closed position.

The upper edge of the ceiling mounting plate can be installed against the ceiling. Alternatively, a concealed mounting method can be used, in which case the ceiling can be 30 mm below the upper edge.

5. Check that the condensate insulation rings (at least exhaust air and outdoor air duct) are in place in the outlet collars below the ceiling mounting plate.
6. Pull out the operating levers **(A)** (**figure 1**) and turn them towards the outer sides of the plate so that they are secured in the open position (**figure 2**).
7. Remove the ventilation unit's door before installing the ventilation unit to the ceiling mounting plate.
8. Lift the ventilation unit close to the ceiling mounting plate and feed the cables and the connection box through the hole in the ceiling mounting plate on top of the ceiling.

**! NOTE:** Remember to make a maintenance hatch in the ceiling so that the cables and the connection box can be accessed. The distance between the maintenance hatch and the ceiling mounting plate should be around 500 mm.

Alternatively, the cables can be fed between the ceiling mounting plate and the ventilation unit to the rear wall.

9. Lift the ventilation unit up against the ceiling mounting plate (**figure 3**). Where needed, guide the mounting hooks on the ceiling mounting plate (**3B**) to the grooves on the side panels of the ventilation unit. Turn the operating levers back to the closed position (**figure 4**). The levers will lock the unit to the ceiling mounting plate (**figure 5**). When the operating levers are in the closed position and the unit has been secured to the ceiling mounting plate, the levers should be level with the front edge of the ceiling mounting plate.
10. Where required, the unit can be detached from the ceiling mounting plate. Remove the door of the unit, lift the unit slightly upwards, pull out both operating levers **(A)** (**figure 1**) and and turn them towards the outer sides of the plate so that they are secured in the open position (**figure 2**).

**! NOTE:** Tighten the upper nut of the thread bars adequately so that the ceiling mounting plate cannot rise upwards.

### Attic floor feedthrough plate

The top panel feedthrough plate is an optional accessory. When an attic floor penetration plate is used the tightness of the vapour barrier has to be ensured.

The attic floor penetration plate is installed at the same level as the rear wall of the ventilation unit. The minimum distance of the attic floor penetration plate from the rear wall is 10 mm, and the width varies depending on the model. Follow the model-specific instructions on the penetration plate.

## 2.3. Removal of condensing water

**NOTE:** The unit comes with the Vallox Silent Klick siphon package. See the instructions for siphon installation in the package or at <https://www.vallox.com>. When using an alternative siphon installation method, move the washer and locking part to the pipe connection mounted to the wall.

Figure 1. Dimensioning figure and space required for installation of the Vallox Silent Klick siphon

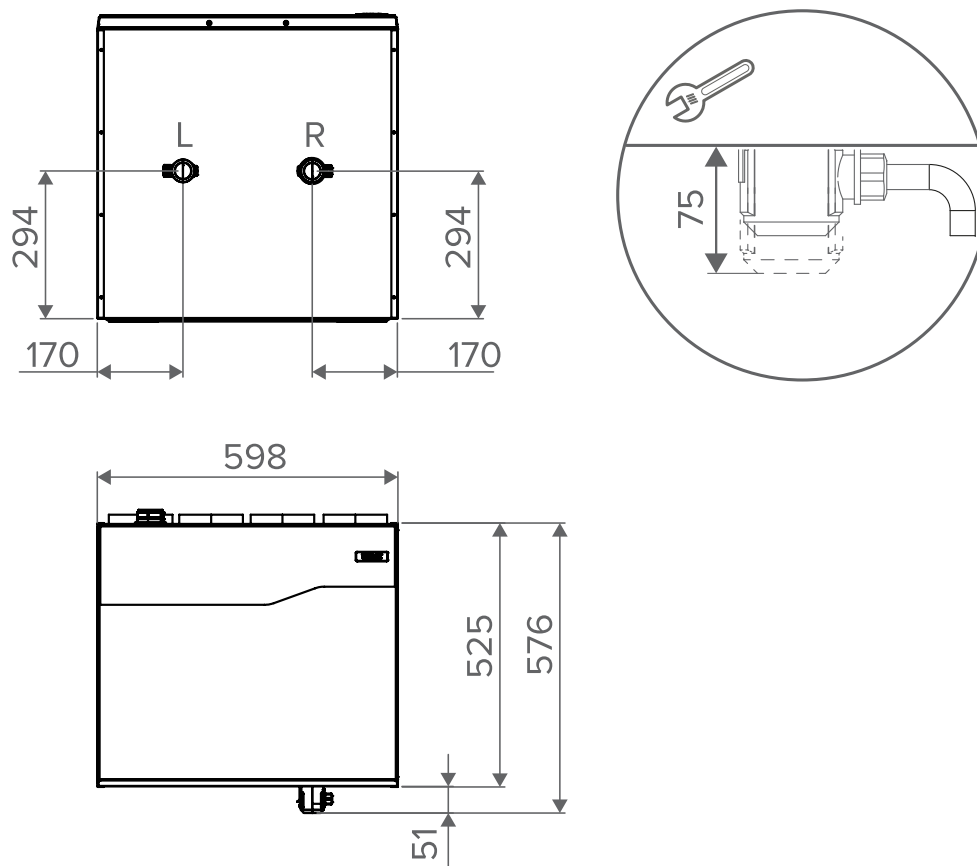
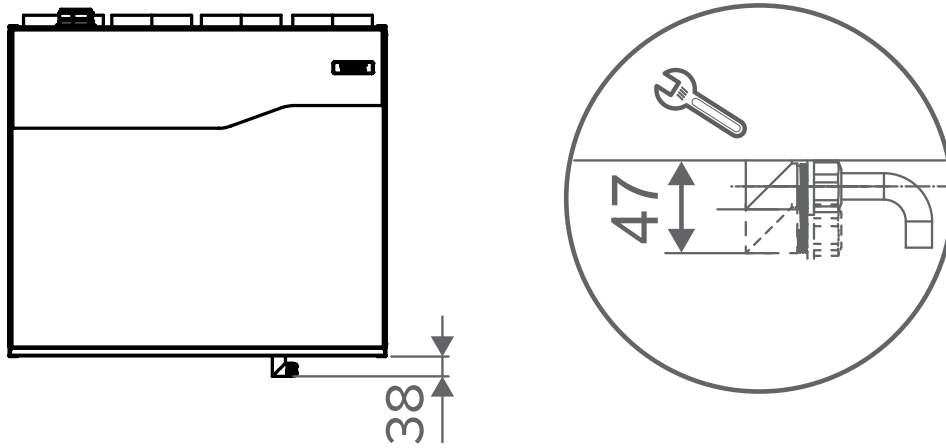

Figure 2. Space required by the alternative Vallox Silent Klick water seal installation method (elbow)



---

## 3. VENTILATION UNIT CONTROL OPTIONS

The Vallox ventilation unit can be controlled by the following means:

- Through the MyVallox control panel installed to the building
- Through the MyVallox Home LAN connection and the MyVallox Home/Cloud user interface
- Through the MyVallox Cloud service and the MyVallox Home/Cloud user interface
- Through a remote monitoring or building automation system that uses voltage signals or Modbus messages.

The ventilation unit's integrated humidity and carbon dioxide sensors control ventilation automatically, as necessary. Ventilation can also be adjusted automatically by using an optional carbon dioxide, humidity, or VOC (air quality) sensor. When these sensors are used, ventilation remains optimal even when the apartment is unoccupied. The standard equipment and available optional accessories vary from country to country.

Each user can use the week clock to adjust the ventilation to fit their lifestyle and schedule.

**TIP:**

The MyVallox control panel automatically switches to the sleep mode when the pre-set **Sleep time** has elapsed. To reactivate the MyVallox control panel, press any button.

### 3.1. Connecting the ventilation unit to the cloud service

You can connect the ventilation unit to the MyVallox Cloud service. In the cloud service, you can control ventilation remotely with a smartphone or tablet, for example. The unit software is updated automatically through the cloud service. To connect to the cloud service, the ventilation unit must be connected to the internet through LAN and registered for the cloud service. By registering the unit, you create a MyVallox Cloud account for yourself. Read more about the service at <https://cloud.vallox.com>.

To register a Vallox ventilation unit with the MyVallox Cloud service:

1. Connect one end of the network cable to the grey connector of the Vallox ventilation unit and the other end to the router.
2. Open the computer's network settings by selecting **Start** → **My Computer** → **Network**. You can see a computer icon with the text Vallox and a series of numbers. Open the MyVallox Home user interface by double clicking on the icon. The MyVallox Home user interface opens.

**OR**

---

Select on the MyVallox control panel **Service menu** → **Diagnostics display** → **IP address**. Type in the IP address and press Enter. The MyVallox Home user interface opens.

3. Select Special functions.
4. The MyVallox Cloud area will open and you can see whether you are signed in to the cloud service.
5. Select **Connect**.
6. The registration page of the MyVallox Cloud cloud service opens, **Ventilation unit ID** i.e. the unique identification number of the unit will be automatically generated into the field.
7. Enter the following information in the form:
  - **Ventilation unit name** - Enter the ventilation unit name of your choice in this field.
  - **Language** - Select the desired language from the menu.
  - **Country** - Select the desired country from the menu.
  - **Choose username** - Enter the username of your choice in this field.
  - **Email** - Enter the email address of your choice in this field.
  - **Password** - Enter the password of your choice in this field.
  - **Retype your password** - Retype your password in this field.
8. Select the **I want to receive notifications related to my ventilation unit** box if you wish to receive email notifications related to your ventilation unit.
9. Read the terms and conditions of use of the service and select **I have read and accepted the terms and conditions of use of the MyVallox Cloud cloud service**. The use of the service requires that the user has accepted the terms and conditions.
10. Select **Create MyVallox Cloud account**. The ventilation unit generates a unique identification code and sends it to the service. The service will remember the unit the next time you sign into the cloud service.
11. A confirmation message will be sent to your email address. Click on the link in the message to confirm your email address and to sign in to the cloud service for the first time.
12. Once you have signed in, the MyVallox Cloud service will open and the main page of the MyVallox Cloud account will be displayed in your browser.

## 3.2. Connecting the ventilation unit to a computer

To use a computer as a second controller alongside the MyVallox control panel, connect the computer directly to the Vallox ventilation unit.

Before starting, ensure that you have:

- A computer with a browser that supports Web Sockets data transmission. Supported browsers:
  - Firefox, version 31 or higher.
  - Internet Explorer, version 10 or higher.
  - Opera, version 25 or higher.
  - Chrome, version 31 or higher.

- Safari, version 7 or higher.
- An internet connection to the Vallox ventilation unit with a network cable (RJ-45).

To use the Vallox ventilation unit through the MyVallox Home user interface:

1. Start the computer.
2. Connect one end of the network cable to the computer's Ethernet port and the other end to the grey Ethernet port of the Vallox ventilation unit.

**! NOTE:**

You can also connect the Vallox ventilation unit to a router. In that case, the Vallox ventilation unit can be connected to the MyVallox Cloud service. You can also use a WLAN network by connecting the Vallox ventilation unit to a computer.

3. On the computer, select: **Start** → **My Computer** → **Network**.
4. Please wait until you see a computer icon with the text **Vallox** and a series of numbers. Double-click on the icon to open the MyVallox Home user interface in your browser. The ventilation unit is now connected to the computer.

**OR**

You can skip steps 3 and 4 and:

- a. Select on the MyVallox control panel **Service menu** → **Unit information** → **IP address**. The MyVallox Home user interface opens in your browser.
- b. Type in the IP address and press **Enter**

### 3.3. Registering the ventilation unit in the MyVallox Cloud service

This section explains how to register the Vallox ventilation unit in the MyVallox Cloud service.

When the ventilation unit is connected to the MyVallox Cloud service, you can control ventilation remotely with a smartphone or tablet, for example. The unit software is updated automatically through the cloud service. To connect to the cloud service, the ventilation unit must be connected to the internet through LAN and registered for the cloud service. By registering the unit, you create a MyVallox Cloud account for yourself.

To register a Vallox ventilation unit with the MyVallox Cloud service:

1. Connect one end of the network cable to the grey connector of the Vallox ventilation unit and the other end to the router's LAN port (usually numbered 1,2,3,4). The LAN port must not be bridged, i.e. it must share private IP addresses (addresses that begin with 10.x.x.x, 172.x.x.x or 192.168.x.x).

**TIP:**

If the ventilation unit rejects the IP address and it is not possible to connect the unit to the intranet, go to the router settings and make sure the DHCP server is on and it is sharing private IP addresses (addresses that begin with 10.x.x.x, 172.x.x.x or 192.168.x.x).

2. Open the computer's network settings by selecting **Start** → **My Computer** → **Network**. You can see a computer icon with the text **Vallox** and a series of numbers.

**OR**

Select on the MyVallox Control control panel **Service menu** → **Unit information** → **IP address**. Type in the IP address and press **Enter**.

3. Open the MyVallox Home user interface by double-clicking on the icon.

4. Select **Special functions**. 
5. Under **Cloud service**, you can see whether you are signed in to the MyVallox Cloud service.

**Cloud service**

You are not signed in into the MyVallox Cloud cloud service.

**Connect**

6. Select **Connect**.
7. The registration page of the MyVallox Cloud service opens. The **Ventilation unit ID**, i.e. the unit's unique identifier, is generated automatically in the field.

Register your Vallox ventilation unit to start using the service

I already have an account: [Log in](#)

Ventilation unit ID:  
4147A205-334D-41C5-9B72-695C7048A6F2 \*

Ventilation unit name:  
\*

Language:  
\*

Country:  
\*

Email:  
\*

Password:  
\*

I want to receive notifications related to my ventilation unit:

I have read and accepted the terms and conditions of use of the MyVallox Cloud cloud service:

[Create MyVallox Cloud account](#)

8. Enter the following information in the form:
  - **Ventilation unit name** — Enter the ventilation unit name of your choice in this field.
  - **Language** — Select the desired language.
  - **Country** — Select the desired country.
  - **Email** — Enter your email address in this field. The email address is your username.
  - **Password** — Enter the password of your choice in this field.
9. Select the **I want to receive notifications related to my ventilation unit** box if you wish to receive notifications related to your ventilation unit.
10. Select **I have read and accepted the terms and conditions of use of the MyVallox Cloud cloud service** and read the terms and conditions of use of the service. The use of the service requires that the user has accepted the terms and conditions.
11. Select **Create MyVallox Cloud account**. The ventilation unit generates a unique identification code and sends it to the service. The service will remember the unit the next time you sign into the cloud service.

- 
12. A confirmation message will be sent to your email address. Click on the link in the message to confirm your email address and to sign in to the cloud service for the first time.
  13. Once you have signed in, the MyVallox Cloud service will open and the main page of the MyVallox Cloud account will appear in your browser.

#### My devices

---

[Demo Machine](#)

Last seen:

--

Device ID:

8853824E-C597-4ECC-BDC0-9C23DCC6344F



## 4. MAINTENANCE

This section describes the maintenance of the Vallox ventilation unit.

**⚠ WARNING:** The safety switch automatically turns off the power when the upper door of the Vallox ventilation unit is opened. **Always disconnect** the Vallox ventilation unit from the mains before starting maintenance.

**⚠ WARNING:**  
If you are using water to clean unit parts, be careful that the water does not touch the electrical parts.

**! IMPORTANT:**  
If the power cord is damaged, the manufacturer, its service representative or other person with similar qualifications must replace it to avoid danger.

**! NOTE:**  
Vallox ventilation units are available in two models: a left-handed (L) and a right-handed (R) model. The images below depict the right-handed model.  
In the right-handed model, outdoor air enters the unit from the right side of the centre line, as shown in these instructions. In the left-handed model, outdoor air enters the unit from the left. Correspondingly, the placement of the filters, HR cell bypass damper and heating resistor is reversed.

The table below indicates the recommended maintenance intervals for different Vallox ventilation unit parts.

Table 1. Recommended maintenance intervals for Vallox ventilation unit parts

Part	Year 1				Year 2			
	Spring	Summer	Autumn	Winter	Spring	Summer	Autumn	Winter
Filters	x		x		x		x	
Cell								x
Fans	x		x		x		x	
Siphon			x					x
General cleaning and visual check			x					x

---

## 4.1. Replacing the filters

When the maintenance reminder becomes activated, check the cleanliness of the filters and replace them if required.

The Vallox ventilation unit has three air filters:

- Coarse filter for supply air filters insects, heavy pollen and other relatively large foreign objects out of the outdoor air.
- Fine filter for supply air filters microscopic pollen and dust particles out of the supply air.
- Coarse filter for extract air filters the extract air and keeps the heat recovery cell clean.

The filter replacement interval depends on the ambient particle concentration. It is recommended that the filters be replaced every spring and autumn, or, at the very least, once a year.

**! NOTE:**

Using original Vallox filters ensures that the ventilation unit remains in top condition, giving the best results. Selection and ordering of filter packages: [filters.vallox.com](https://filters.vallox.com)

**! NOTE:** The service space in front of the ventilation unit must be at least 500 mm.

To replace the filters:

1. Disconnect the ventilation unit from the mains electricity supply.
2. Lift off the door cover panel. Undo the door's mounting screws (4 mm hexagon).
3. Lift the door off.

**! CAUTION:** The door is heavy.

4. Remove the old filters (**A, B, C**) and discard them.

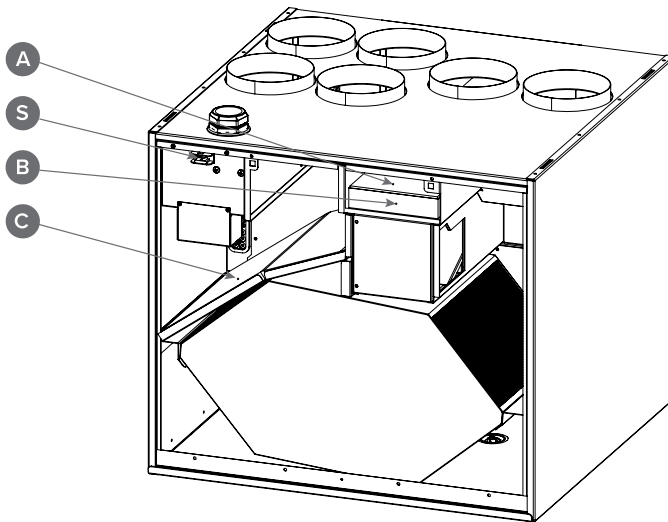

5. Install the new filters (**A, B, C**).
6. Close the door of the unit. Ensure that the safety switch catch of the door is touching the safety switch (**S**), allowing the unit to be turned on. Tighten the door tightening screws only to the extent that the outdoor damper of the door comes into contact with the frame of the unit. The outdoor damper of the door must not be pressed in around the screws.
7. Plug the ventilation unit back into the mains.

The filters have now been successfully replaced.

## 4.2. Cleaning the heat recovery cell

**⚠ WARNING:** The safety switch automatically turns off the power when the upper door of the Vallox ventilation unit is opened. **Always disconnect** the Vallox ventilation unit from the mains before starting maintenance.

Check that the heat recovery cell is clean roughly once a year, or whenever the filters are being replaced. Clean by washing as required.

To check and clean the heat recovery cells:

1. Disconnect the ventilation unit from the mains electricity supply.
2. Remove the door cover panel. Undo the unit's mounting screws (4 mm hexagon).
3. Lift the door off.

**⚠ CAUTION:** The door is heavy.

4. Remove the extract air filter (**B**).
5. Unlock the locking nuts in the upper support of the cell (**A**) and pull the upper support of the cell outwards.

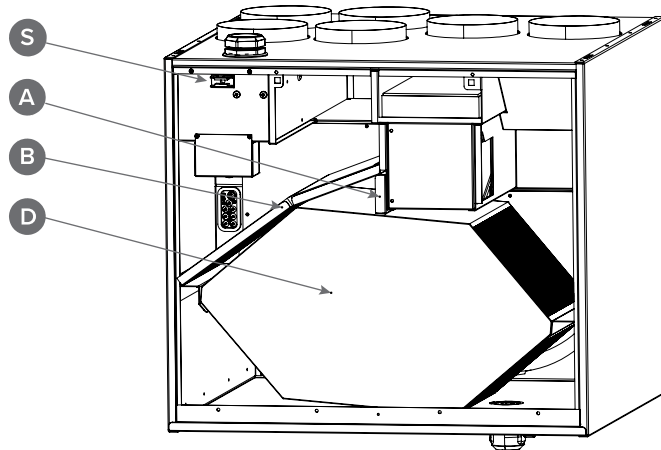

6. Lift and pull the HR cell (**D**) out of the unit.

**! IMPORTANT:** Handle the cell carefully! For example, do not lift the cell by the layers. The cell layers are very thin and easily damaged.

7. If the cell is dirty, clean it by immersing it in warm water, to which a small amount of a mild detergent has been added.
8. Rinse the cell clean with a water spray. Do not use a high-pressure cleaner.
9. When all the water has drained from between the layers, reassemble the ventilation unit as follows:

10. Ensure that the lower support (**C**) is in place against the knobs at the bottom of the unit.

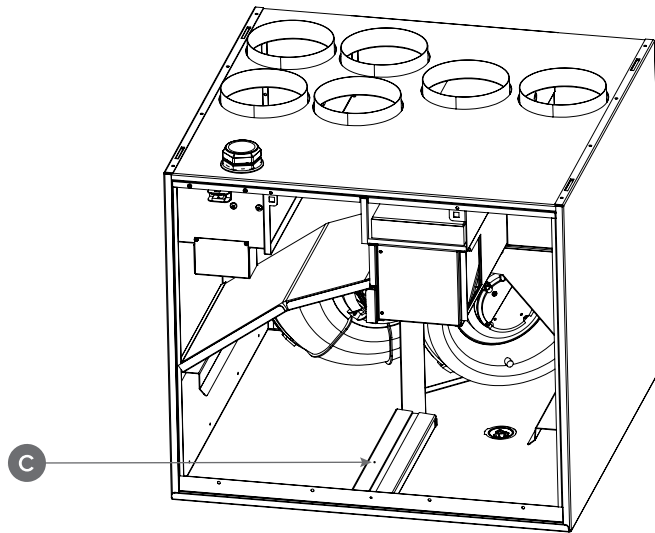

11. Lift the HR cell in place.
12. Push the upper support (**A**) against the cell. Ensure that the upper support is properly nestled against the cell (remains upright). Tighten the locking nuts.
13. Install the extract air filter (**B**) in place.
14. Close the door. Ensure that the safety switch catch of the door is touching the safety switch (**S**). Tighten the door tightening screws only to the extent that the outdoor damper of the door comes into contact with the frame of the unit. The outdoor damper of the door must not be pressed in around the screws.
15. Plug the ventilation unit back into the mains.

The heat recovery cell has now been checked and cleaned.

### 4.3. Cleaning the fans

Check the condition of the fans in connection with filter replacement and HR cell maintenance. Clean the fans if necessary.

You can clean the fan blades with compressed air (wear protective goggles) or by brushing them gently. Do not remove or move the balance blocks on the fan blades.

To clean the fan:

1. Disconnect the ventilation unit from the mains electricity supply.
2. Remove the door cover panel. Undo the unit's mounting screws (4 mm hexagon).
3. Lift the door off.

 **CAUTION:** The door is heavy.

4. Remove the filters and the heat recovery cell. See sections [Replacing the filters](#) and [Cleaning the heat recovery cell](#).
5. Remove the support plate (**F**) by undoing the screws (**E**).

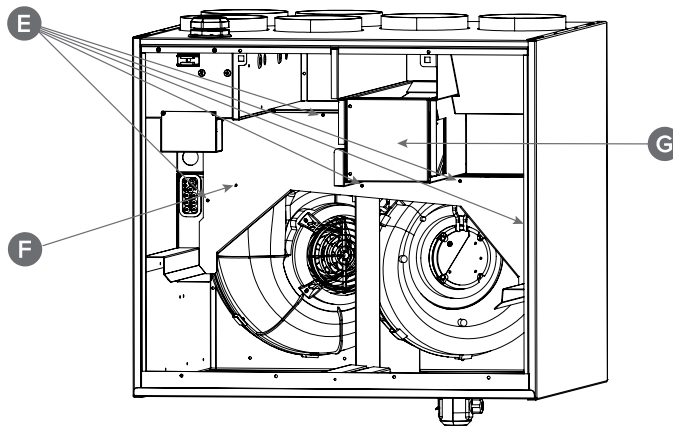

6. Detach the bypass module (**G**) cable from the connector (found in front of the extract air fan (in front of **P**)). Pull the bypass module (**G**) out of the unit.
7. Remove the plastic nuts used to fasten the fans (**J**) (2 per fan). Remove the two wing screws (**I**) (2 pcs) of the additional heating resistor (**H**) (only when changing the supply air fan) and remove the cable of the resistor (**H**) from the connector.
8. Remove the fan from the unit by lowering it before turning the fan anti-clockwise, whilst tilting it. Remove the control grille by undoing the screws (4 pcs).

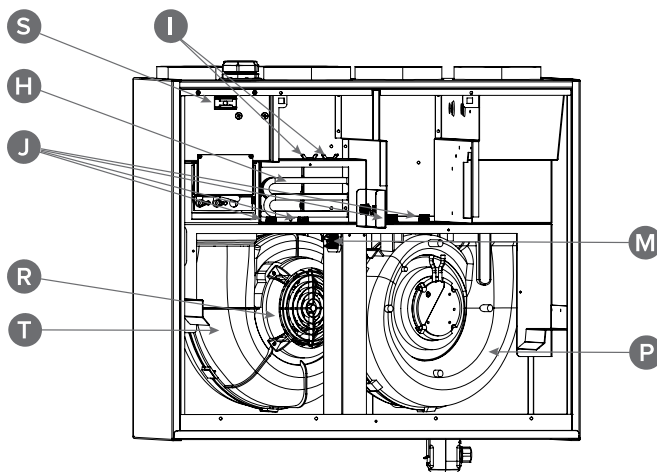

9. You can now clean the fan. Put the control grille (**R**) back in place after cleaning.
10. Reassemble in reverse order after cleaning. After reassembling the fan, ensure that the rubber feedthrough (**M**) is in place.
11. Close the door. Ensure that the safety switch catch of the door is touching the safety switch (**S**). Tighten the door tightening screws only to the extent that the outdoor damper of the door comes into contact with the frame of the unit. The outdoor damper of the door must not be pressed in around the screws.
12. Plug the ventilation unit back into the mains.

---

**! IMPORTANT:**

Remember to reattach the damper actuator bar to the damper pivot and secure it with the orange magnet. Make sure the sensors and their feedthrough rubbers are in place. Check also that the connections have been made correctly and the earthing screw is in place in the left corner.

## Cleaning the anemometer

The anemometer in the fan must be cleaned at least every three (3) years. It is recommended to use compressed air (max 2–3 bar) for the cleaning.

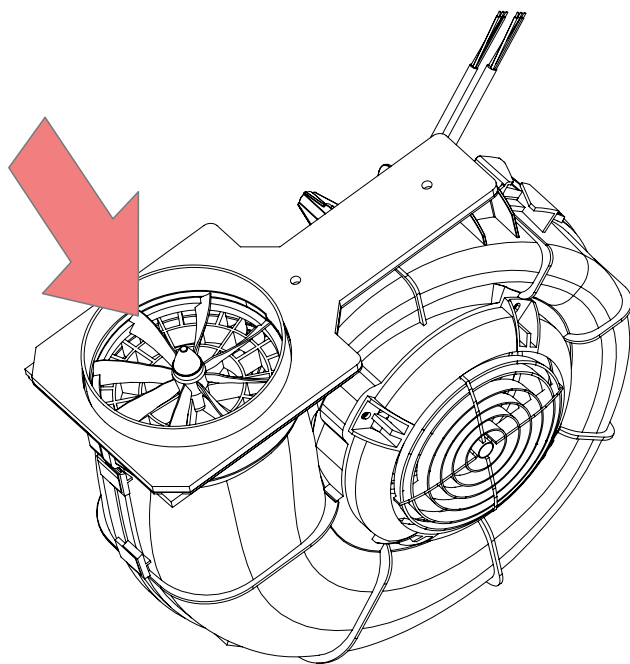

**! IMPORTANT:**

When using compressed air, the arms of the anemometer must not be allowed to freely. This could damage the bearings.

**! IMPORTANT:**

Cleaning with a brush is not recommended. This could damage the arms.

## 4.4. Condensing water

In the heating season, the extract air humidity condenses to water. In new buildings, condensation runoff can form rapidly. Condensed water must be able to freely leave the unit.

**! NOTE:**

Some condensing water may have accumulated in the bottom pool of the unit; this is normal and requires no corrective action.

At some time before the heating season begins (e.g. during autumn maintenance), check that the siphon or the condensing water outlet in the bottom pool are not clogged. To check this, pour some water into the pool. Clean as required.

**! WARNING:**

Water must at all times be kept out of the electrical system.

## 4.5. Updating the unit software (MyVallox Control)

To update the ventilation unit software through the MyVallox Control panel:

1. Download the latest update package to your computer from the home page of the MyVallox Cloud service <https://cloud.vallox.com>. You can find the latest update under Latest firmware version.

**! NOTE:** The name of the update file must always be the same: HSWUPD.BIN. If you have downloaded an older update file to your computer, delete it before downloading the new update to make sure the file name does not change.

2. Connect the computer to the ventilation unit control panel with a USB Micro-B connector.

**! NOTE:**

- The MyVallox control panel cannot be used when it is connected to the computer. A USB icon is shown on the control panel.
- If the computer is unable to find the ventilation unit, you are probably using a charging cable. Try another USB Micro-B cable.

3. When the ventilation unit is turned on, the control panel appears as an external drive in the computer's resource management.
4. Copy the new update package HSWUPD.BIN and paste it to the control panel, i.e. the root of the external drive.

**! IMPORTANT:** Do not change the file name.

- 
5. Make sure the update package has been completely transferred to the control panel by selecting Safely Remove USB. This is an OS-specific function.
  6. Disconnect the USB cable.
  7. The control panel loads the update for a moment (you can see the process on the panel) and starts to transfer the update package to the ventilation unit in the background. This takes approximately 4–5 hours.
  8. When the update is complete, the unit launches the new software and restarts itself automatically.

**! NOTE:** The ventilation unit must stay on throughout the update process. If the ventilation unit's power is cut off during the process, the transfer time of 4–5 hours starts from the beginning.

**! NOTE:** If a red error screen appears on the control panel, the update must be downloaded again. Go back to step 1.

When the update is complete, the software version shown on the **Unit information** screen should be the same as the version at <https://cloud.vallox.com>.

## 4.6. Troubleshooting

The table below provides instructions for troubleshooting and repair.

### ! IMPORTANT:

We recommend you always use the latest software version. You can check the latest version at <https://cloud.vallox.com>.

### ! NOTE:

Error messages are displayed on the control panel and in the MyVallox Home and MyVallox Cloud services.

Error	Cause	Follow these steps
Error message: Extract air fan	The extract air fan has stopped.	Make sure the fan has really stopped. Check the fan wires and operation. If necessary, the fan must be replaced. Contact the service centre.
Error message: Supply air fan	The supply air fan has stopped.	Make sure the fan has really stopped. Check the fan wires and operation. If necessary, the fan must be replaced. Contact the service centre.
Error message: Temperature sensor 1/2/3/4/5	A temperature sensor indicated by the user interface is damaged.	Check the sensor installation. If necessary, the sensor must be replaced. Contact the service centre.
Error message: High supply air temperature	The supply air temperature is too high.	Check the operation of the post-heating and additional heating resistors. Make sure the resistors are on in the user interface. If necessary, contact the service centre.
Error message: Low supply air temperature	The supply air temperature is too low.	Check the operation of the post-heating and additional heating resistors. Make sure the resistors are on in the user interface. If necessary, contact the service centre.
Error message: Bus error	Problems in data transmission.	Make sure that the control panel and any external sensors are connected and working correctly.
Both the ventilation unit and the control panel do not work.	The unit's power supply has been cut off or the safety switch pusher on the door does not touch the safety switch.	Check: <ul style="list-style-type: none"> <li>• Fuse on the fuse panel</li> <li>• The unit's glass tube fuse. Contact the service centre.</li> <li>• Push in the safety switch and check does the unit start up. If the unit starts up, make sure the safety switch pusher on the door is pressing on the safety switch.</li> </ul>
The ventilation unit works but the control panel does not work.	The control panel's 24 VDC supply has been cut off, there are problems in data transmission or the control panel is damaged.	<ul style="list-style-type: none"> <li>• Check the cords between the unit and the control panel.</li> <li>• Unplug the unit and restart the unit.</li> <li>• Update the unit software.</li> <li>• Contact the service centre.</li> </ul>

## 5. TECHNICAL SPECIFICATIONS

Object	MyVallox 125 CFI
Product titles	MyVallox 125 CFI R MyVallox 125 CFI L
Type code	3766
Electrical connection	230 V, 50 Hz, 9.3 A power plug
Enclosure protection class	IP34
Fans	<ul style="list-style-type: none"> <li>• Supply air — 0.17 kW 1.35 A EC</li> <li>• Extract air — 0.17 kW 1.35 A EC</li> </ul>
Air volumes	<ul style="list-style-type: none"> <li>• Supply air — 107 dm<sup>3</sup>/s, 100 Pa</li> <li>• Extract air — 111 dm<sup>3</sup>/s, 100 Pa</li> </ul>
Heat recovery bypass	Automatic
Post-heating	Electrical resistor, 900 W
Pre-heating	-
Additional heating	Electrical resistor, 900 W
Filters	<ul style="list-style-type: none"> <li>• Supply air — ISO Coarse &gt; 75% + ISO ePM<sub>1</sub> ≥ 50 %</li> <li>• Extract air — ISO Coarse &gt; 75%</li> </ul>
Specific energy consumption (SEC)	In a cold climate — A+ In a temperate climate — A
Efficiencies*	<ul style="list-style-type: none"> <li>• Annual efficiency — 75%</li> <li>• Supply air efficiency — 81%</li> <li>• Specific Fan Power (SFP) — 1.54 kW/m<sup>3</sup>/s (75 dm<sup>3</sup>/s)</li> </ul>
Dimensions (w × h × d)	598 x 525 x 601 mm
Weight	66 kg

\*Working point defined in the Ecodesign Directive (2009/125/EC), Southern Finland, Helsinki-Vantaa TRY year 2020.

## 5.1. Supply/extract air volumes and input powers

Figure 3. Supply and extract air volumes

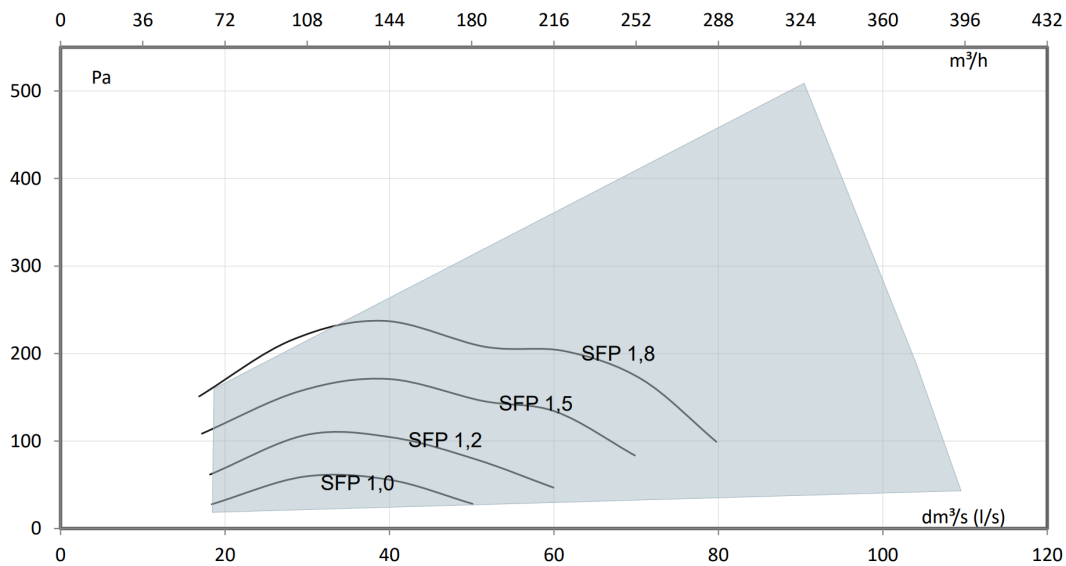

$$\text{SFP} = \frac{\text{Input power (total) (W)}}{\text{Air flow (max) (dm}^3\text{/s)}}$$

The recommended SFP (Specific Fan Power) rate is <math><1.8 \text{ (kW m}^3\text{/s)}</math>. At a lower total pressure, the SFP rate is lower.

Table 2. Fan input power

	l/s	m <sup>3</sup> /h	Pa	W
<b>Min</b>	18	65	97	26
<b>Mid</b>	60	216	119	86
<b>Max</b>	104	373	188	311

You can calculate the operating-point-specific input power with the *Vallox MySelecta* product selection program.

## 5.2. Sound values

Sound power level in the supply air duct (one duct) by octave band $L_W$ dB										
Air flow l/s		20	30	40	50	60	70	80	90	110
Medium frequency of the octave band Hz	63	60	63	66	70	74	78	80	82	82
	125	56	60	62	64	66	69	70	73	78
	250	52	57	61	63	65	67	69	73	72
	500	39	45	50	54	58	61	64	71	70
	1000	40	46	52	56	59	62	65	67	69
	2000	28	37	43	48	52	56	59	62	63
	4000	18	26	34	40	45	49	53	56	58
	8000	22	22	26	32	38	43	48	51	53
$L_W$ dB		66	66	69	72	76	79	81	84	84
$L_{WA}$ dB(A)		52	52	56	60	63	66	69	73	73

Sound power level in the extract air duct (one duct) by octave band $L_W$ dB										
Air flow l/s		20	30	40	50	60	70	80	90	110
Medium frequency of the octave band Hz	63	52	55	60	66	70	75	77	80	82
	125	45	50	53	57	59	62	64	67	69
	250	35	43	48	53	55	58	60	62	64
	500	26	31	36	40	45	46	50	51	59
	1000	17	24	30	34	38	41	43	46	48
	2000	13	15	20	24	29	33	36	39	42
	4000	16	16	17	18	21	24	27	30	34
	8000	22	22	21	22	22	22	24	26	29
$L_W$ dB		53	57	61	66	70	75	77	80	82
$L_{WA}$ dB(A)		33	38	43	47	51	54	56	58	61

Sound pressure level coming through the envelope of the unit in the room in which it is installed (10 m <sup>2</sup> sound absorption)										
Air flow l/s		20	30	40	50	60	70	80	90	100
$L_{pA}$ dB (A)		24	29	34	38	41	45	48	50	51

The operating-point-specific sound values can be calculated with the *Vallox MySelecta* product selection program.

### 5.3. Internal electrical connection

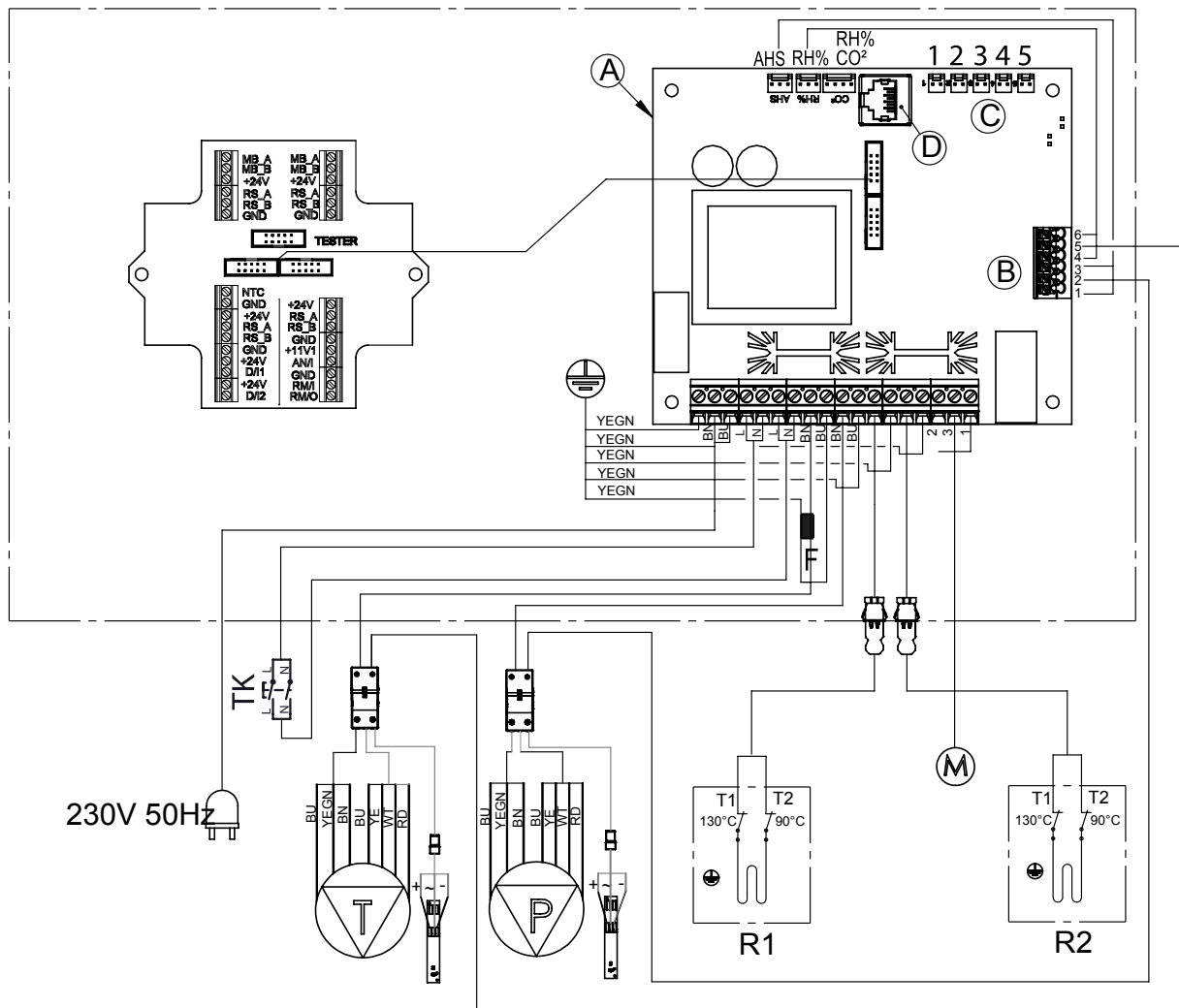

<b>A</b>	Motherboard	<b>11V1</b>	11.1 V operating voltage
<b>B</b>	<ol style="list-style-type: none"> <li>1. Extract air fan tachometer (WT)</li> <li>2. GND (GN)</li> <li>3. Extract air fan PWM (YE)</li> <li>4. Supply air fan tachometer (WT)</li> <li>5. GND (GN)</li> <li>6. Supply air fan PWM (YE)</li> </ol>	<b>AN/I</b>	Analog input 0–10 VDC
<b>C</b>	<ol style="list-style-type: none"> <li>1. Extract air</li> <li>2. Outdoor air</li> <li>3. Supply air</li> <li>4. Exhaust air</li> <li>5. Supply air from the HR cell</li> </ol>	<b>RM/I</b>	24 V relay input

<b>D</b>	LAN	<b>RM/O</b>	24 V relay output
<b>MB_A</b>	External Modbus A signal	<b>T</b>	Supply air fan
<b>MB_B</b>	External Modbus B signal	<b>P</b>	Extract air fan
<b>+24V</b>	+24V voltage (DC)	<b>F</b>	Choke
<b>GND</b>	Digital and analog ground potential	<b>M</b>	Damper motor
<b>RS_A</b>	Local hardware Modbus A signal	<b>AHS</b>	Air flow measuring sensor for extract air fan
<b>RS_B</b>	Local hardware Modbus B signal	<b>%RH</b>	Air flow measuring sensor for supply air fan
<b>NTC</b>	External temperature sensor connector	<b>%RH CO<sub>2</sub></b>	Internal humidity and carbon dioxide sensor
<b>D/I1</b>	Digital input 1	<b>R1</b>	Post-heating resistor with 90°C and 130°C overheating protection
<b>D/I2</b>	Digital input 2	<b>R2</b>	Additional heating resistor with 90°C and 130°C overheating protection

Table 3. Cable colours

Code	Colour	Code	Colour
<b>BK</b>	Black	<b>GN</b>	Green
<b>BU</b>	Blue	<b>RD</b>	Red
<b>BN</b>	Brown	<b>YE</b>	Yellow
<b>WT</b>	White	<b>YEGN</b>	Yellow-green

## 5.4. External electrical connection

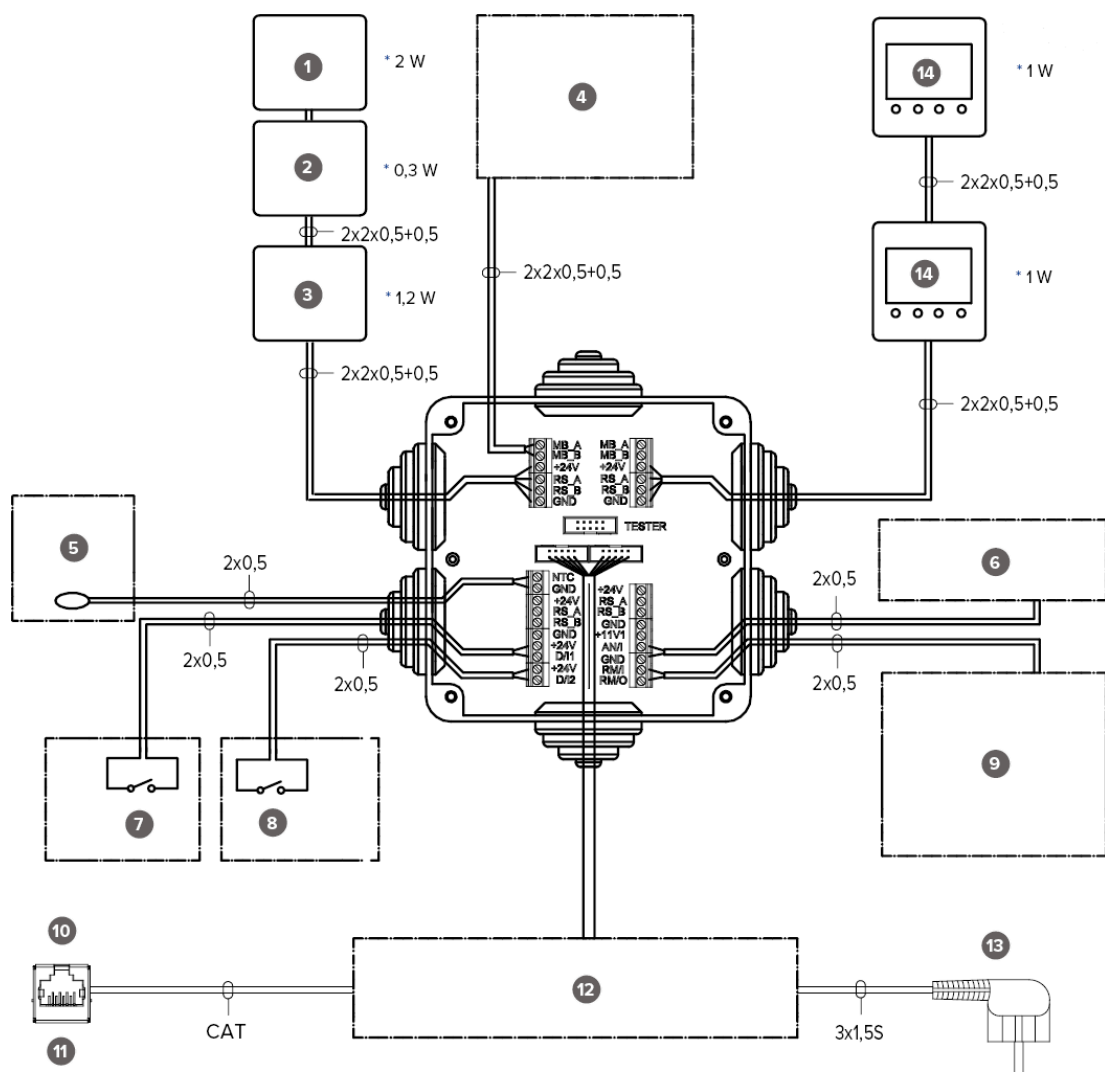

\*  $\Sigma$  = max. 6 W

1	MyVallox VOC sensor	8	Digital input 2. 8 different functions.
2	MyVallox %RH sensor	9	Potential-free contact data 24 VDC (max 3 A, 72 W) can be programmed to display information such as errors or to control the valve and pump of the MLV radiator.
3	MyVallox CO <sub>2</sub> sensor	10	Ethernet connection on top of the unit
4	Remote monitoring Modbus RTU	11	RJ45 female
5	External temperature sensor NTC 47K	12	Internal connection of the ventilation unit
6	Analog input. Two separate functions.	13	Plug connection 1.2 m on top of the unit
7	Digital input 1. 8 different functions.	14	MyVallox control panel

<b>MB_A</b>	External Modbus A signal	<b>D/I1</b>	Digital input 1
<b>MB_B</b>	External Modbus B signal	<b>D/I2</b>	Digital input 2
<b>+24V</b>	+24 V voltage (DC)	<b>11V1</b>	11.1 V operating voltage
<b>GND</b>	Digital and analog ground potential	<b>AN/I</b>	Analog input 0-10 VDC
<b>RS_A</b>	Local hardware Modbus A signal	<b>RM/I</b>	24 V relay input
<b>RS_B</b>	Local hardware Modbus B signal	<b>RM/O</b>	24 V relay output
<b>NTC</b>	External temperature sensor connector		

Table 4. Power supply

Object	Feed
<b>Maximum</b>	≤ 6 W
<b>MyVallox Control</b>	1 W
<b>MyVallox Touch</b>	0.5 W
<b>%RH sensor</b>	0.3 W
<b>CO<sub>2</sub> sensor</b>	1.2 W
<b>VOC sensor</b>	2 W
<b>Voltage</b>	24 VDC

## 5.5. External electrical connection for controlling the MLV duct radiator

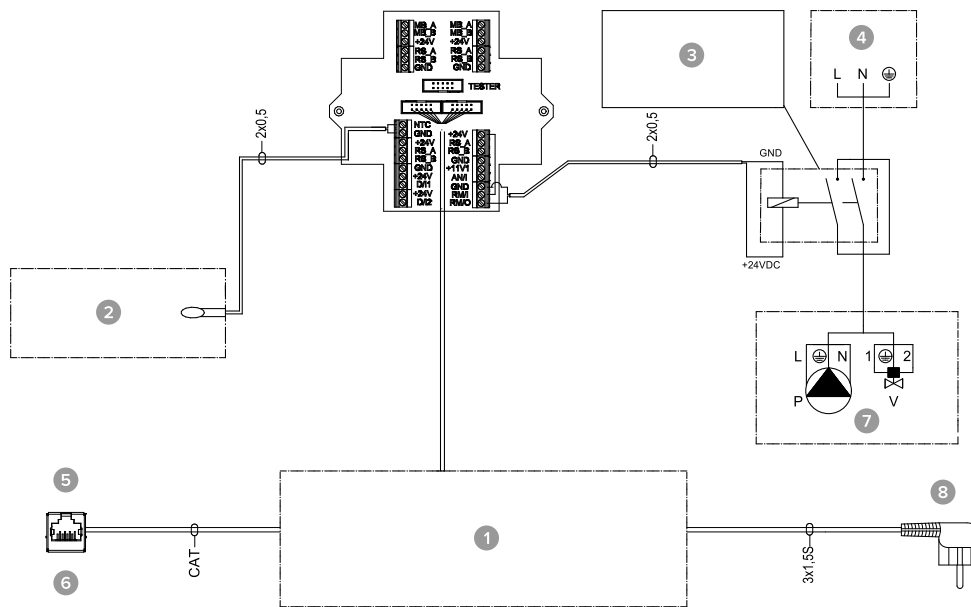

No.	Name	No.	Name
1	Internal connection of the ventilation unit	5	Ethernet connection on top of the unit
2	External temperature sensor NTC 4K7	6	RJ45 Female
3	24 VDC relay/contactor for controlling the pump and solenoid valve	7	MLV control
4	Distribution board	8	Plug connection 1.2 m on top of the unit

<b>MB_A</b>	External Modbus A signal	<b>D/I2</b>	Digital input 2
<b>MB_B</b>	External Modbus B signal	<b>11V1</b>	11.1 V operating voltage
<b>+24V</b>	+24 V voltage (DC)	<b>AN/I</b>	Analog input 0-10 VDC
<b>GND</b>	Digital and analog ground potential	<b>RM/I</b>	24 V relay input
<b>RS_A</b>	Local hardware Modbus A signal	<b>RM/O</b>	24 V relay output
<b>RS_B</b>	Local hardware Modbus B signal	<b>P</b>	Circulation pump
<b>NTC</b>	External temperature sensor connector	<b>V</b>	Solenoid valve
<b>D/I1</b>	Digital input 1		

---

## 5.6. Duct radiator operation

**Always primarily follow the connection plan provided by the HVAC designer or heat pump manufacturer.** Remember to also read the duct radiator's instructions for use.

The accompanying figure shows an example of the arrangement for connecting the heating/cooling radiator unit to the heat collection circuit.

**NOTE:**

If the duct radiator is used in the supply air duct, it can only be used for cooling.

The output pipe of the radiator unit is connected to the return pipe of the heat collection circuit. The liquid returning from the radiator unit is circulated back to the heat collection circuit's return pipe. If it is known that the pressure losses inside the heat collection circuit's heat pump are too great, bypassing the heat pump is recommended. In that case the liquid is circulated when the heat pump is at rest, and the pressure loss of the bypass' one-way valve Y2 must be smaller than the pressure loss of the heat pump.

**Heating:** The pump is switched on when the outdoor air temperature drops below the factory-set winter limit (-5°C).

**Cooling:** The target supply air temperature set for the unit's mode (e.g. At Home mode) determines when the pump is switched on. The pump is switched on when the supply air setting is lower than the temperature of the air supplied.

The duct radiator can be installed in the supply air duct or the outdoor air duct. If the radiator is placed in the outdoor air duct, it can be used for pre-heating and cooling. If the radiator is placed in the supply air duct, it can only be used for heating or cooling.

**NOTE:**

To control the outdoor air duct radiator, an external NTC sensor is installed in the outdoor air duct before the radiator. To control the supply air duct radiator, an external NTC sensor is installed after the radiator.

The duct radiator can be set to work automatically or manually.

- **Automatic operation:** In summer, the set supply air temperature is maintained. In winter, the duct radiator is switched on when the outdoor air temperature drops below the winter setting.
- **Manual operation:** In summer, the duct radiator is switched on when the outdoor air temperature rises above the summer setting. In winter, the duct radiator is switched on when the outdoor air temperature drops below the winter setting.

To prevent the risk of condensation in the supply air duct, you can set the adjustment of the supply air limit to automatic or manual.

- Automatic adjustment: The supply air limit is adjusted automatically according to the extract air dew point. When the supply air temperature drops too low, the duct radiator is switched off.
- Manual adjustment: The supply air limit is set manually. When the supply air temperature drops below the set value, the duct radiator is switched off.

If you are using an external sensor, go to the external sensor settings and select either outdoor air duct radiator or supply air duct radiator control. The external sensor's temperature reading is displayed in the maintenance menu: **Menu> > Service menu> > Unit information (page 5)> > External sensor.**

**! NOTE:**

When choosing the relay (C), take into account the maximum joint power supply of the motherboard of the MV electric box (max. 6 W), if the relay is supplied by the motherboard's +24 V connector.

**! NOTE:**

Due to the risk of humidity damage, in a duct that has not been insulated for condensation the supply air temperature must not fall below +16 ... 20 °C.

Figure 4. Duct radiator operation chart in the outdoor air duct

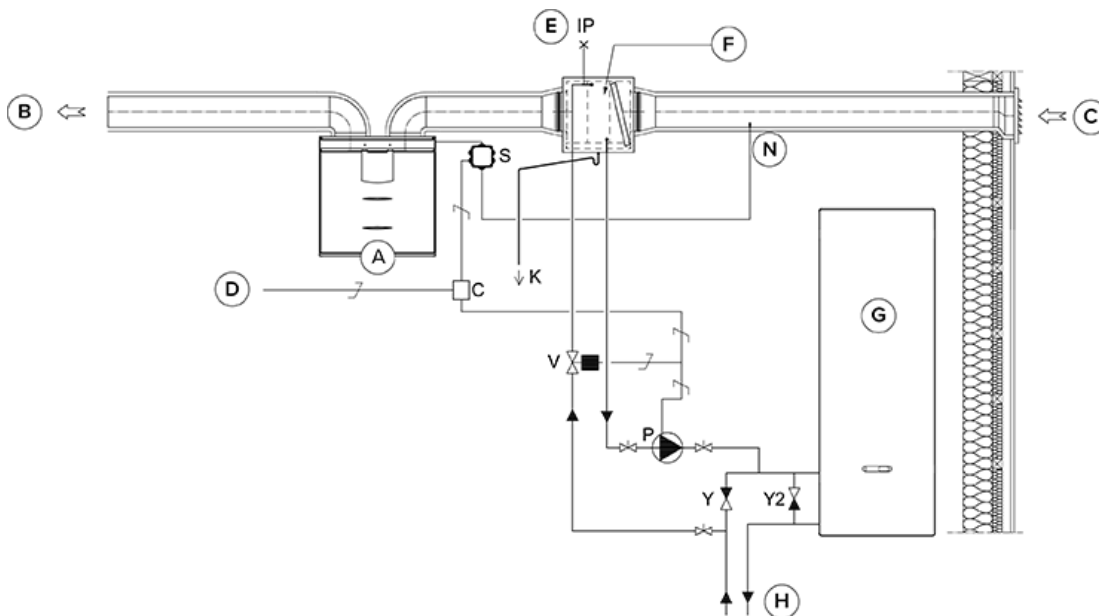
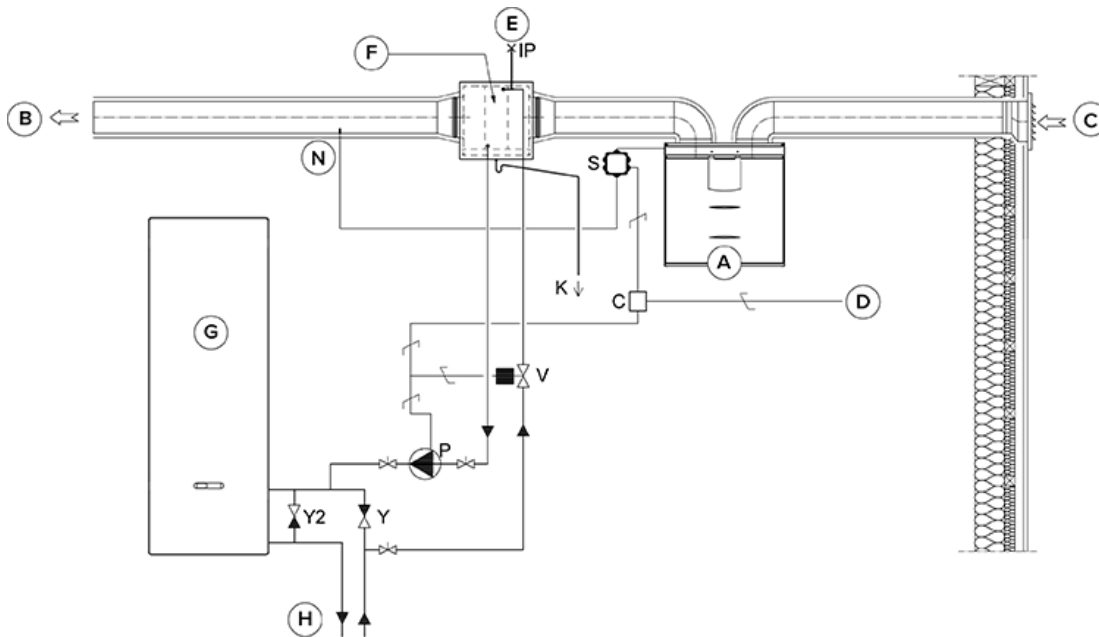

Figure 5. Duct radiator operation chart in the supply air duct



Name	Name
<b>A</b> Ventilation unit	<b>P</b> Circulation pump. Not included in delivery. Due to a risk of condensation, use a pump that is suitable for pumping liquid colder than the environment (e.g. Grundfos Magna 1 25-80).
<b>B</b> Supply air	<b>V</b> Solenoid valve. Not included in delivery. The valve should be suitable for heat collection circuit liquid (e.g. Danfoss 032U161431, HVAC code 4122110).
<b>C</b> Outdoor air	<b>K</b> Condensing water tube. Not included in delivery.
<b>D</b> Feed from the distribution board	<b>IP</b> De-aerator. Not included in delivery.
<b>E</b> Air extraction	<b>S</b> External electrical junction box for the MV
<b>F</b> Duct radiator (reverse connection)	<b>C</b> 24 VDC Relay/contacter for controlling the pump and solenoid valve. Not included in delivery. (e.g. ABB CR-P024DC2).
<b>G</b> Heat pump	<b>Y</b> One-way valve. Not included in delivery.
<b>H</b> Heat collection circuit	<b>Y2</b> One-way valve. Not included in delivery. The pressure loss must be smaller than the pressure loss of the heat pump.
<b>N</b> External NTC sensor	

## 5.7. Dimensions and duct outlets

Figure 6. Dimensions MyVallox 125 CFi

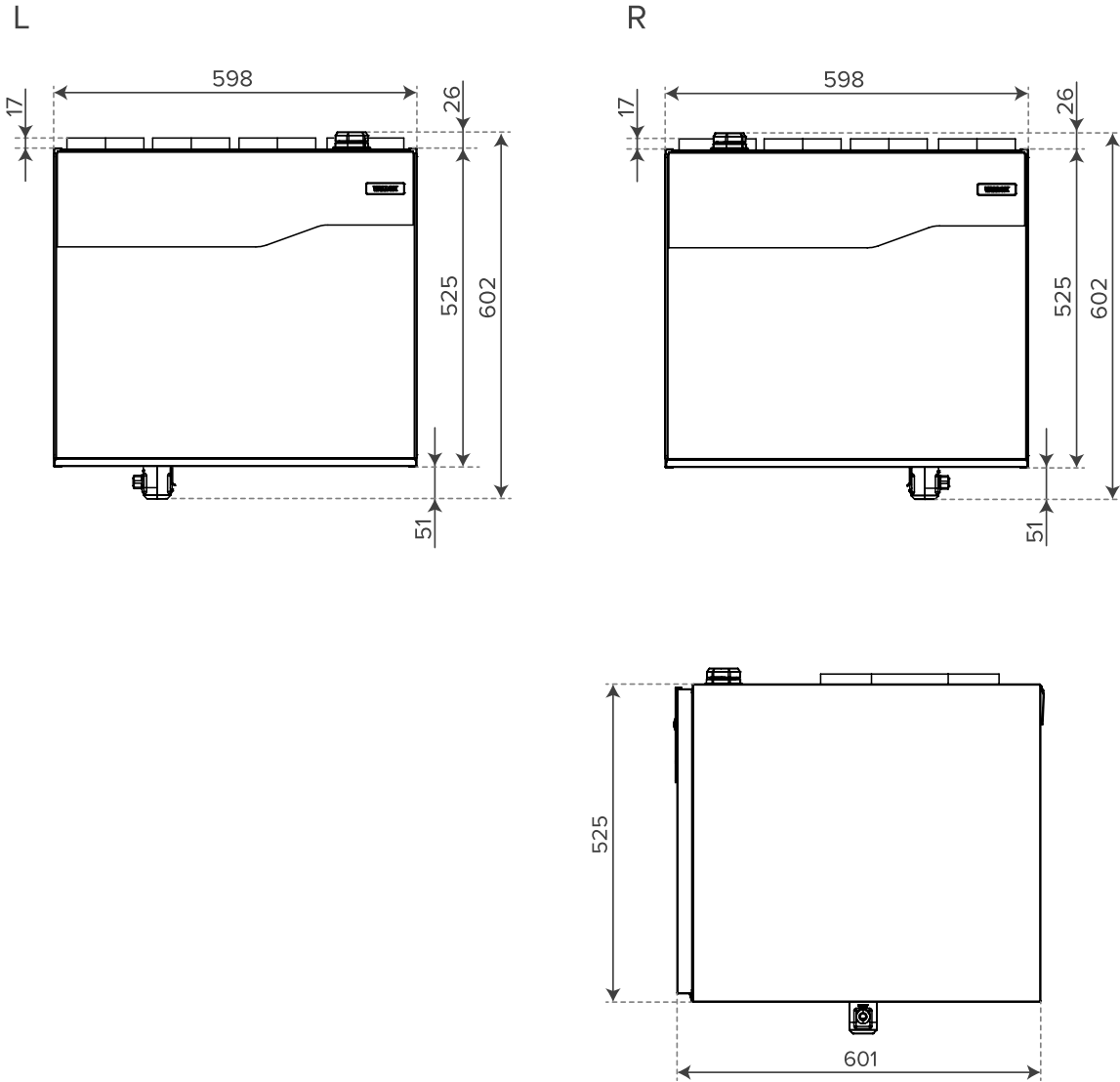

Figure 7. Dimensions and duct outlets 125A

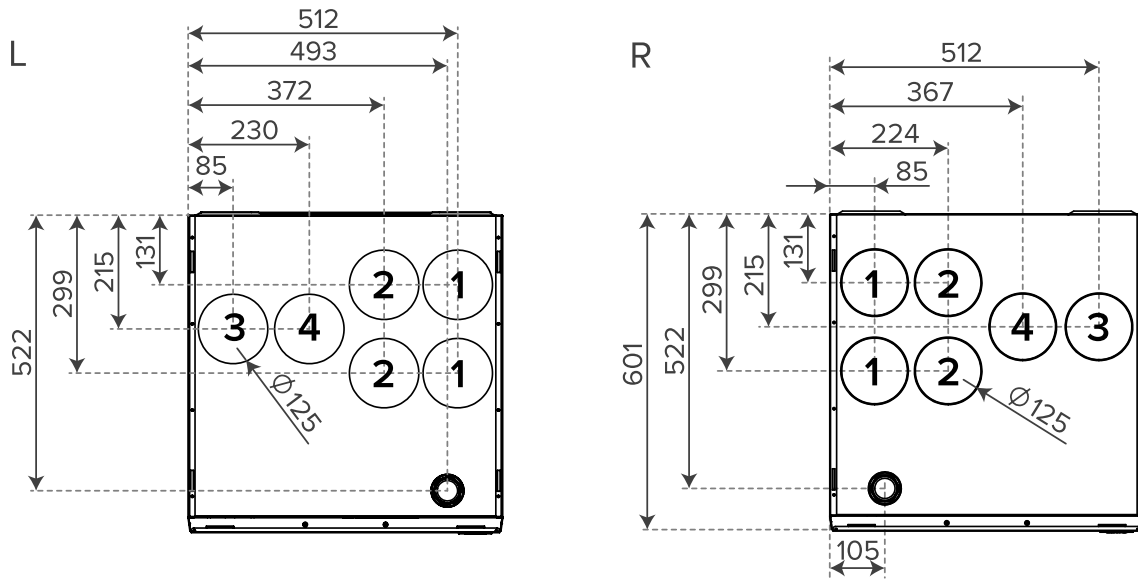

Figure 8. Dimensions and duct outlets 125B

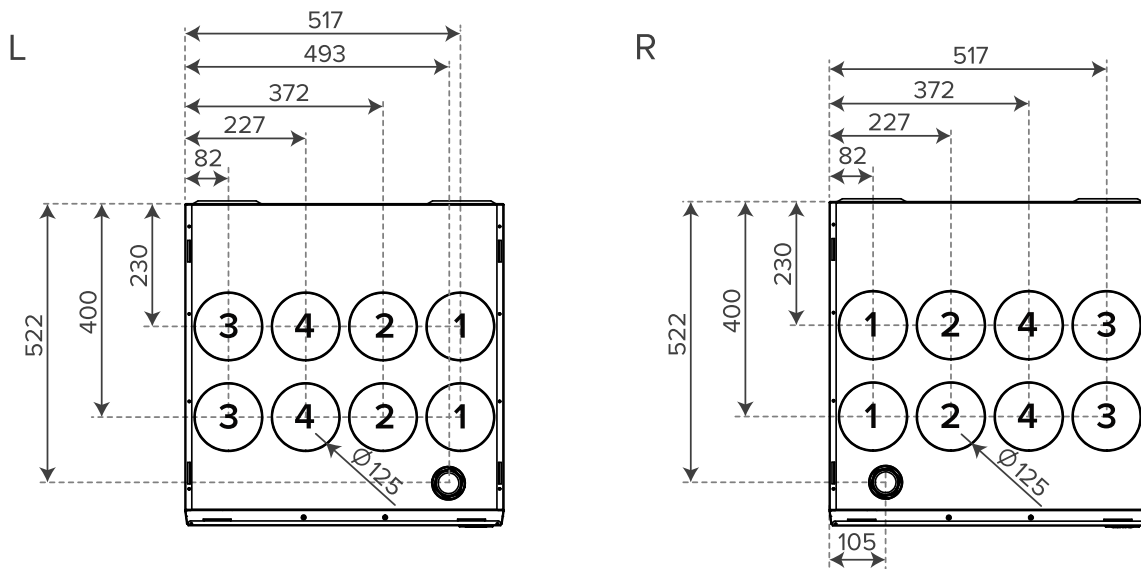

Figure 9. Dimensions and duct outlets 125C

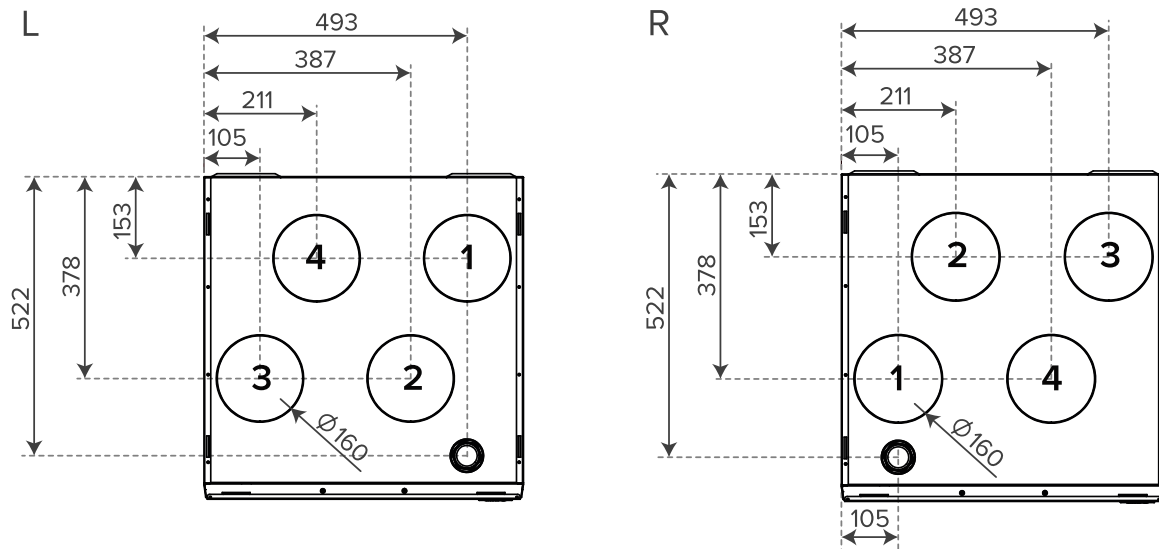

Figure 10. Dimensions and duct outlets 125D

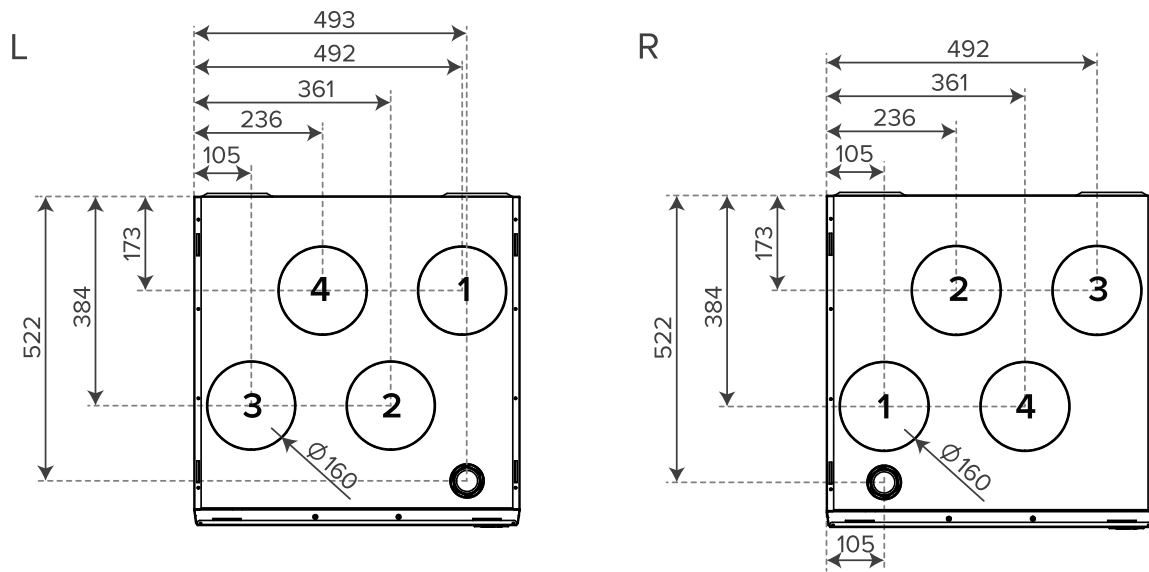

Figure 11. Dimensions and duct outlets 125E

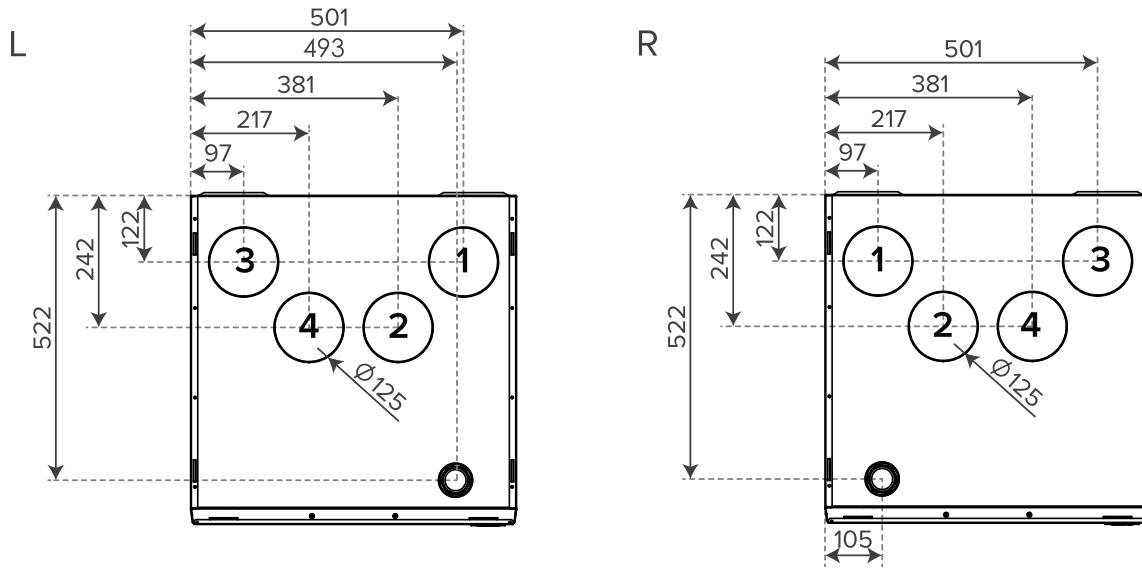

Figure 12. Dimensions and duct outlets 125F

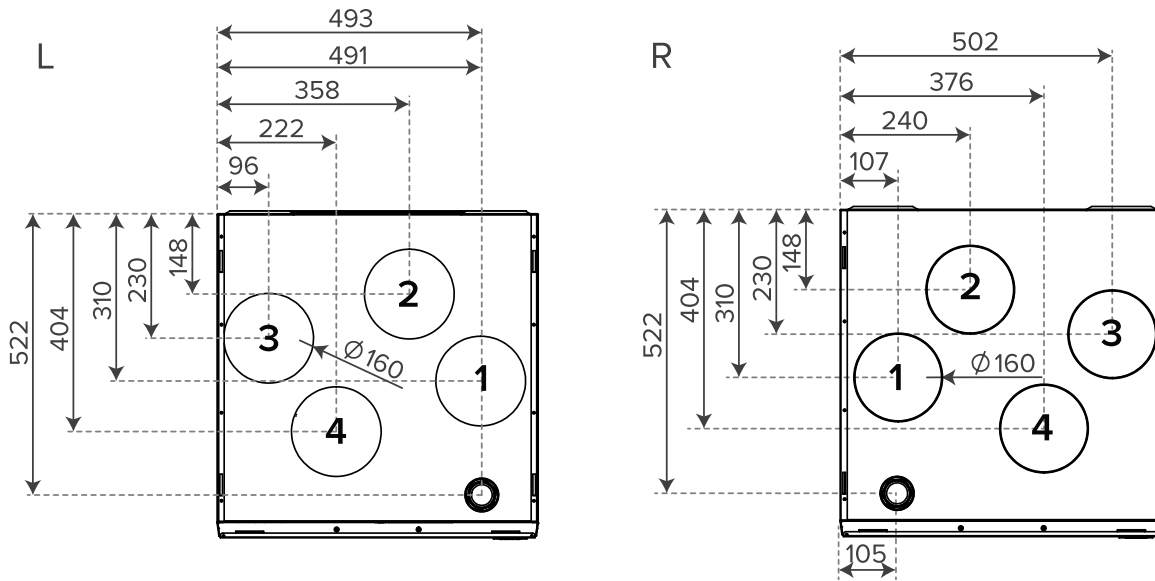

Figure 13. Dimensions and duct outlets 125G

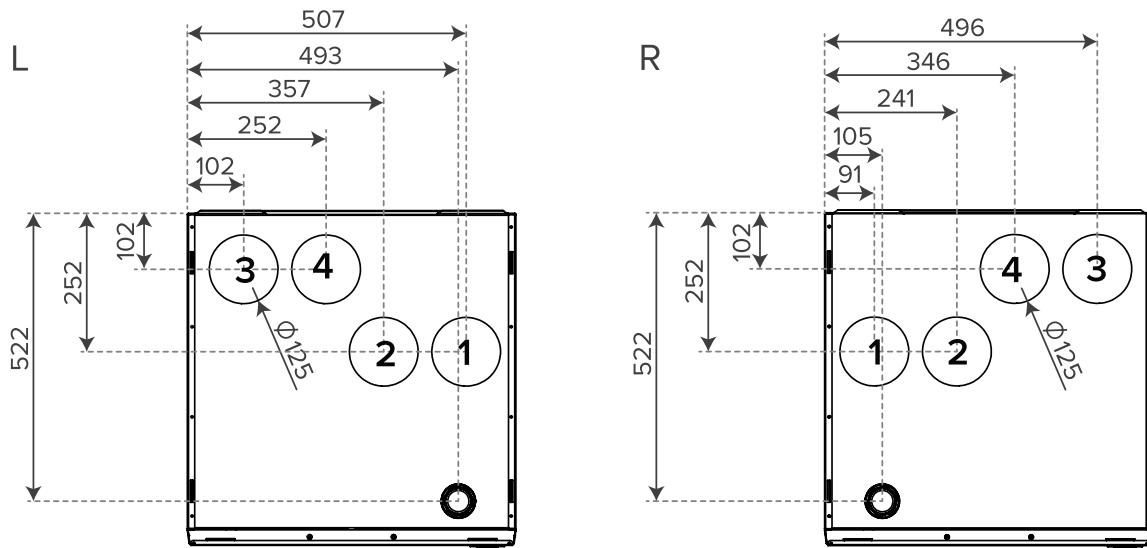
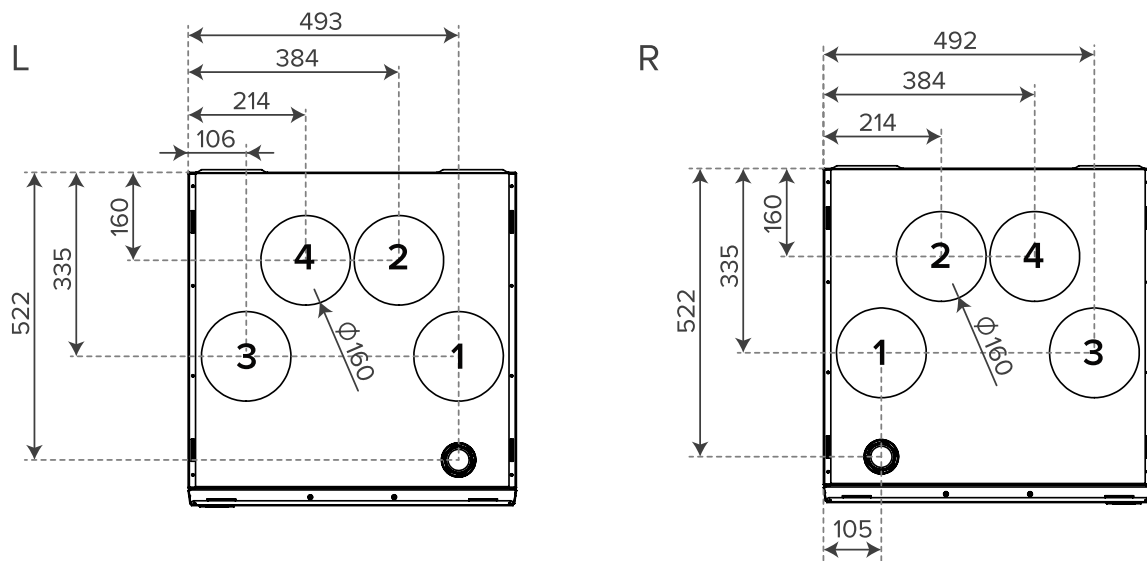

Figure 14. Dimensions and duct outlets 125H



## Duct outlets

The inner diameter of the female outlet collar is 125 mm or 160 mm, depending on the model.

1. Supply air from the unit to the apartment
2. Extract air from the apartment to the unit
3. Exhaust air flowing outdoors from the unit
4. Outdoor air to the unit

## 6. EXPLODED VIEW AND LIST OF SPARE PARTS

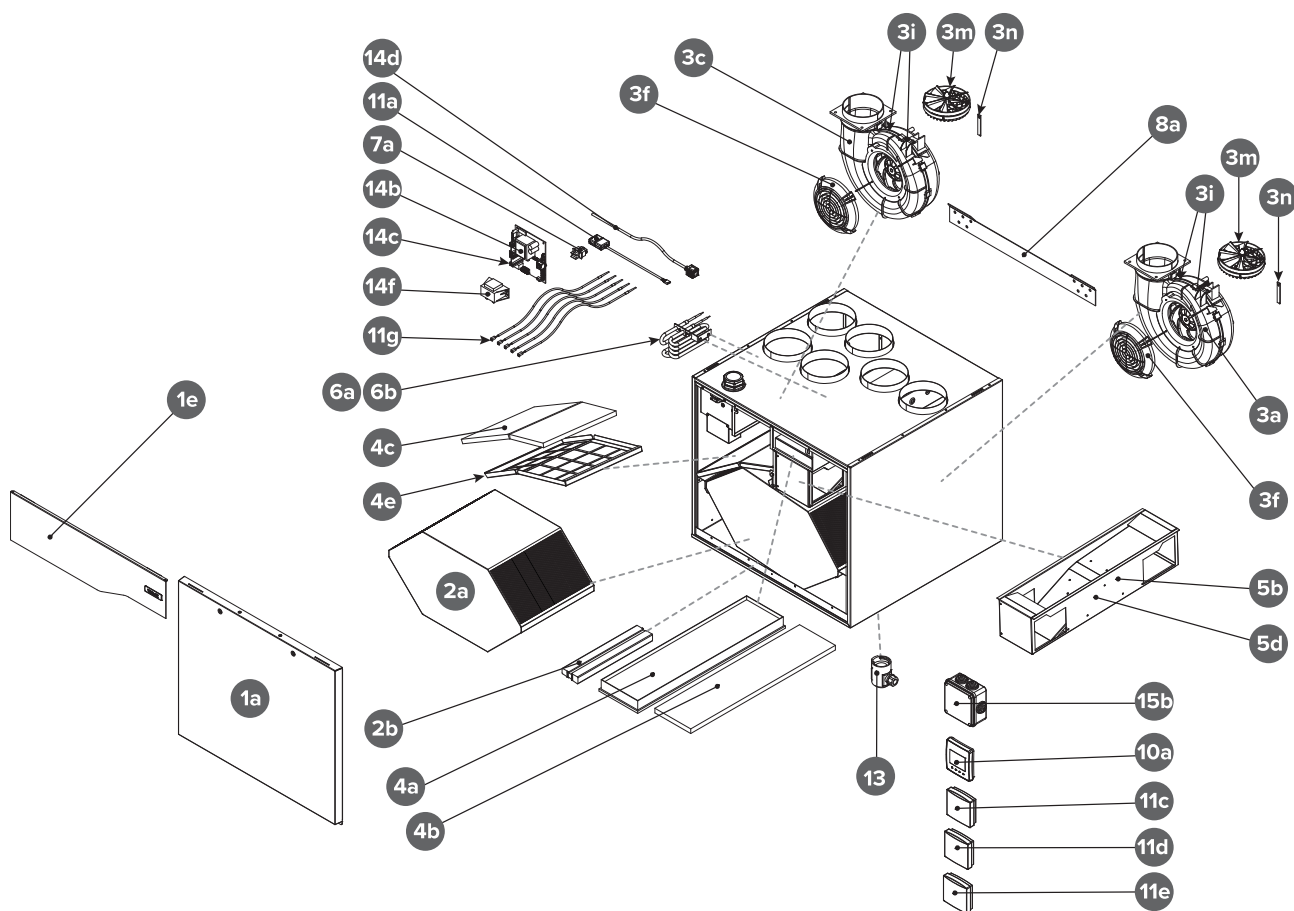

No.	Part	No.	Part
1a	Door	6a	Post-heating resistor
1e	Door cover panel	6b	Additional heating resistor
2a	HR cell	7a	Safety switch
2b	Lower support of the HR cell	8a	Wall mounting plate
3a	Extract air fan	10a	Control panel
3c	Supply air fan	11a	Internal humidity and carbon dioxide sensor
3f	Air flow control grille	11c	MyVallox carbon dioxide sensor (optional)
3i	Plastic nut M5x16x12	11d	MyVallox humidity sensor (optional)
3m	Anemometer	11e	MyVallox VOC sensor (optional)
3n	Hall sensor circuit board	11g	NTC sensor kit
4a	Fine filter for supply air	13a	Siphon Vallox Silent Klick
4b	Coarse filter for supply air	14b	Motherboard
4c	Coarse filter for extract air	14c	Glass tube fuse 63mA slow 5x20mm

---

No. Part

4e Extract air filter frame

5b Bypass damper actuator

5d HR cell bypass damper assembly

No. Part

14d RJ-45 extension cable

14f Choke

15b Connection box

# 7. DECLARATION OF CONFORMITY



DECLARATION OF CONFORMITY

## DECLARATION OF CONFORMITY

**Manufacturer** Vallox Oy  
**Address** Myllykyläntie 9-11, FIN-32200 LOIMAA, FINLAND  
**Telephone number** +358 10 7732 200  
**The person who compiles the technical file** Petri Koivunen  
Vallox Oy  
Myllykyläntie 9-11, FIN-32200 LOIMAA, FINLAND  
Tel. +358 10 7732 200  
Email [info@vallox.com](mailto:info@vallox.com)  
**Description of unit** Ventilation unit with heat recovery

**Model** MyVallox 51/51K/99/119/125/149/245/ 245 VKL CFI  
Vallox 51/51K SC/MV,  
Vallox 99/125/096/110/145/245/245 VKL MV,  
Vallox 99 MV CF,  
Vallox TSK Multi 50/80 MV,  
ValloPlus 180/180K/270/370/510/520/850 MV,  
ValloPlus 180/270 SC,  
ValloMulti 200 SC/MV, ValloMulti 300 MV

Declares that the ventilation unit for supply and extract air, equipped with heat recovery and operating as part of a ventilation system has been designed and manufactured to the following specifications:

1. Low Voltage Directive (2014/35/EU) – EN 60335-1:2012 + A11:2014, A13:2017 + A1:2919 + A14:2019 + A2:2019; EN 62233:2008
2. EMC Directive (2014/30/EU) – EN 61000-6-1:2007, EN 61000-3-2:2014 + A1:2009 + A2:2009, EN 61000-3-3:2013, EN 61000-6-3:2007 + A1:2011
3. Ecodesign Directive (2009/125/EY) – Commission regulation 1253/2014 – EN 13141-7 Annex B, EN 308, EN 13141-7, ISO 3741, ISO 5135
4. RoHS Directive (2011/65/EU, 2015/863/EU)

This is the original Declaration of Conformity

Loimaa, 22<sup>nd</sup> September 2025

Jukka-Pekka Korja  
Managing Director

Vallox Oy  
Myllykyläntie 9-11  
FI-32200 LOIMAA  
FINLAND

Tel. +358 10 7732 200  
Fax. +358 10 7732 201  
[www.vallox.com](http://www.vallox.com)  
[firstname.familyname@vallox.com](mailto:firstname.familyname@vallox.com)

ALV rek./VAT  
Y-tunnus | Business ID:  
Kotipaikka|Registered Domicile: Loimaa, Finland

F106723509  
0672350-9

# VALLOX

[www.vallox.com](http://www.vallox.com)

Vallox Oy | Myllykyläntie 9-11 | 32200 LOIMAA | FINLAND

D11778/18.06.2026EN/PDF