

VALLOX

Model

MyVallox 245 CFi

Document

D11735

Type

3734

Valid from

01.05.2026

Updated

17.06.2026

My**VALLOX**
245 CFi

User manual



Contents

1. Introduction	3
1.1. Safety	3
1.1.1. Safety signs used in the instructions	4
1.2. Intended use	5
1.3. Warnings	6
1.4. System description	7
1.5. Guarantee	7
1.6. Disposal of the ventilation unit	8
1.7. Differences between the models	8
1.8. Main parts	9
2. Installation	11
2.1. Mounting on the floor	12
2.2. Removal of condensing water	12
3. Ventilation unit control options	13
3.1. Connecting the ventilation unit to the cloud service	13
3.2. Connecting the ventilation unit to a computer	14
3.3. Registering the ventilation unit in the MyVallox Cloud service	15
4. Maintenance	19
4.1. Opening and closing the doors	20
4.2. Changing the filters	22
4.3. Cleaning the heat recovery cell	23
4.4. Cleaning the fans	24
4.5. Removing the resistor	26
4.6. Condensing water	28
4.7. Updating the unit software (MyVallox Control)	28
4.8. Troubleshooting	30
5. Technical specifications	31
5.1. Supply/extract air volumes and input powers	34

5.2. Sound values	37
5.3. Internal electrical connection MyVallox 245 CFI	38
5.4. Internal electrical connection MyVallox 245 CFI VKL.....	40
5.5. External electrical connection.....	42
5.6. External electrical connection for controlling the MLV duct radiator.....	44
5.7. Duct radiator operation.....	45
5.8. Dimensions and duct outlets	48
6. Exploded view and list of spare parts	49
7. Declaration of Conformity.....	51

1. INTRODUCTION

Thank you for choosing a Vallox product. For optimal performance, read the instructions carefully before installation, operation, or maintenance.

1.1. Safety

Safe and appropriate handling requires knowledge of the basic safety regulations, and of the intended use of the ventilation system. Read this manual before operating the ventilation unit. Retain the manual for later reference. If you lose the manual, it can be downloaded from our website.

These instructions contain all the information needed for the safe operation of the unit. All persons who install, operate, and maintain the ventilation unit must follow the provided instructions. Furthermore, all local accident prevention regulations must be observed.

Installation

Installation and setup should be carried out only by qualified experts. Electrical installations and connections must be carried out only by an electrician and in compliance with local regulations

 **NOTE:** For further information, go to <https://www.vallox.com>

1.1.1. Safety signs used in the instructions

 **DANGER:**

Indicates a hazard that will result in death or serious injury if not avoided.

 **WARNING:**

Indicates a hazard that can result in death or serious injury if not avoided.

 **CAUTION:**

Indicates a hazard that can result in minor or moderate injury if not avoided.

 **IMPORTANT:**

Indicates a hazard that can result in damage to property or loss of data if not avoided.

 **NOTE:**

Indicates essential information about the product.

TIP:

Provides additional information about the use of the product and its benefits.

1.2. Intended use

All Vallox ventilation units have been designed to provide appropriate and continuous ventilation so as to present no threat to health and to maintain structures in good condition.

⚠ WARNING:

Ensure that the fireplace air intake is sufficient. Operating certain kitchen range hood, central vacuum cleaner and ventilation unit functions can create underpressure in the indoor air. Combustion gases can then be released from the fireplace into the indoor air.

The following can create underpressure indoors:

- Kitchen range hood or central vacuum cleaner are in operation while there is a fire burning in the fireplace
- The supply air fan is stopped during the defrosting function of the ventilation unit
- The boosted defrosting function of the ventilation unit is being used

Underpressure can prevent fireplace air intake, and combustion gases can then be released into the indoor air.

! IMPORTANT: In order to ensure that the indoor air presents no harm to health and remains optimal also for the structures of the building, ventilation must be kept on without disruptions. It is recommended that ventilation be left turned on during long holidays also. This keeps the indoor air fresh and prevents humidity from condensing in the ventilation ducts and structures. It also reduces the risk of moisture damage.

! IMPORTANT:

Prolonged overpressure can result in damage to the structures of the building.

1.3. Warnings

 **WARNING:** The unit is not intended for use by children under 8 or by persons with reduced sensory, physical or mental capabilities, or whose lack of knowledge and experience do not ensure safe operation of the unit. Such persons can use the unit under supervision, or by following the instructions of someone who is responsible for their safety. Children must be supervised and not be allowed to play with the device.

- The ventilation unit is very heavy.
- The door of the ventilation unit is heavy.
- Water must at all times be kept out of the electrical system.
- The timer function of the Custom mode can only be turned off when the external fireplace switch has a timer.
- The fan settings must be completed by a qualified specialist in accordance with the ventilation plan. If you edit the settings, ensure that they comply with the ventilation plan.
- The safety switch automatically turns off the power when the door of the ventilation unit is opened in connection with maintenance measures. **Always disconnect the ventilation unit from the mains** before starting maintenance.
- If the heating resistor needs to be removed from the unit in connection with maintenance measures, ensure that the relay is not hot before pulling it out of the unit.
- Connect the cables so that they do not touch the resistor.

1.4. System description

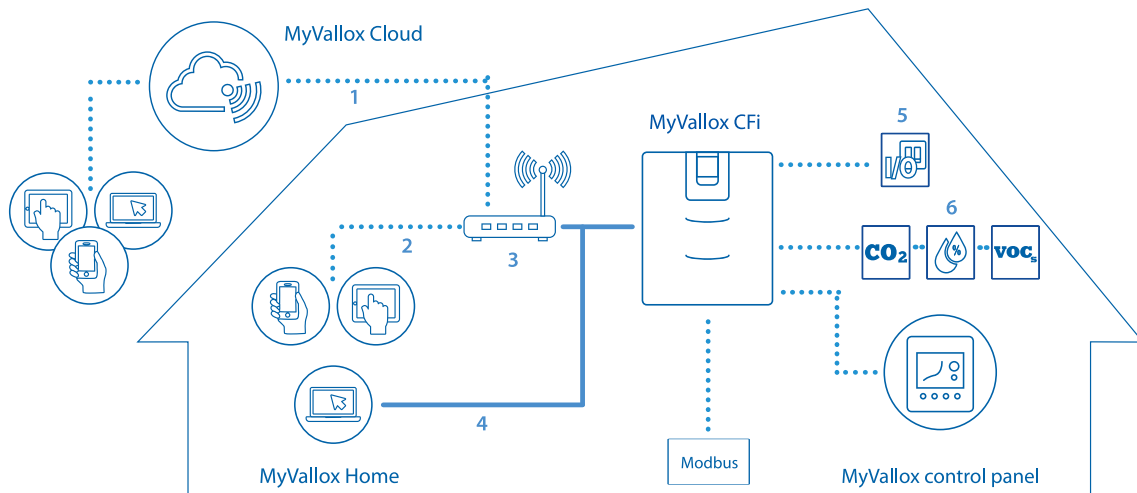

- 1 Internet
- 2 WLAN
- 3 Router
- 4 WLAN/LAN
- 5 Additional switch
- 6 Sensors

1.5. Guarantee

The guarantee and liability exclude damage resulting from:

- Inappropriate use of the ventilation unit or the control panel
- Incorrect or inappropriate installation, setup, or use
- Failure to follow instructions regarding transport, installation, operation, or maintenance
- Structural or electronic modifications or changes made to the software

1.6. Disposal of the ventilation unit

Do not dispose of electronic devices with household waste. Follow local laws and regulations on safe and ecological disposal of the product.

See the MyVallox ventilation unit recycling instructions at: https://res.cloudinary.com/vallox/image/upload/v1704800151/FileStock/ValidManuals/Recycling_Instructions_Vallox_Ventilation_units.pdf.

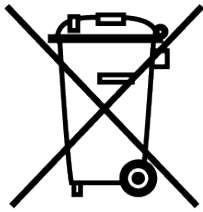







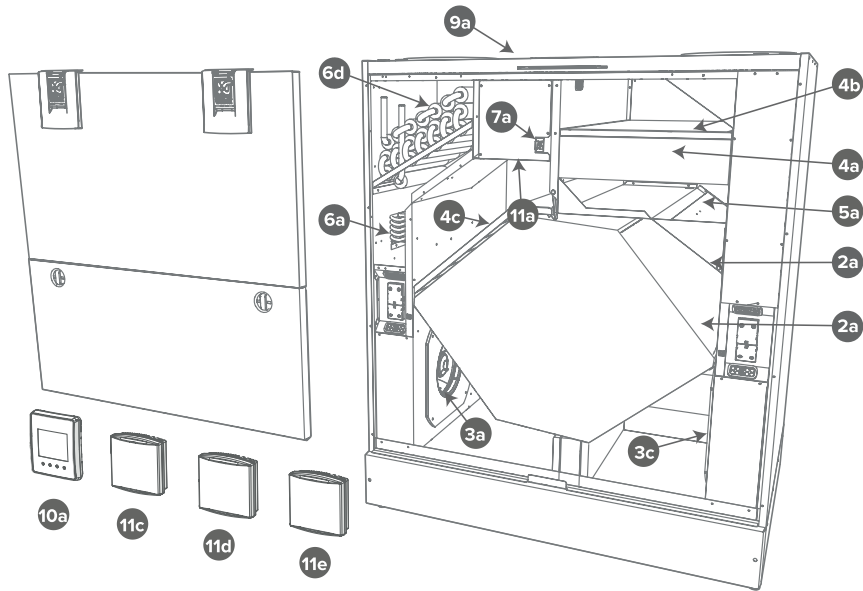









1.7. Differences between the models

- MyVallox 245 CFi has an electric 1500 W post-heating resistor and an electric 1500 W additional heating resistor.
- MyVallox 245 CFi VKL has a liquid circulation post-heating radiator and two electric 1500 W additional heating resistors.

1.8. Main parts



R model in the figure. In the L model, the parts are mirrored.

No.	Part	No.	Part
2a	 Heat recovery cell	6d	 Post-heating liquid radiator (245 CFi VKL)
3a	 Extract air fan	7a	 Safety switch
3c	 Supply air fan	9a	 Ceiling bushing for electric wires
4a	 Fine filter for supply air	10a	 Control panel
4b	 Coarse filter for supply air	11a	 Internal carbon dioxide and humidity sensor
4c	 Coarse filter for extract air	11c	 Carbon dioxide sensor (optional)
5a	 Bypass damper of the HR cell	11d	 Humidity sensor (optional)
6a	 Post-heating resistor (in front of the supply air fan)	11e	 VOC sensor (optional)

2. INSTALLATION

This chapter describes the installation of the Vallox ventilation unit.

Only a qualified technician is allowed to install and set up the unit. Electrical installation and connection work must be carried out by an electrician in line with local regulations.

Check the package contents before installation and make sure that all parts are in good condition. Store the product in a dry place (indoors).

Check the dimensions and weight of the product from the technical specification of the unit.

The ventilation unit must be installed in a dry place where the temperature does not drop below +10°C. When installed without its enclosure, the unit must be placed in a place where its running noise is not bothersome; for example, a storage room, utility room or a false ceiling.

It is normal for frost and ice to accumulate inside the ventilation unit when it is cold. This does not require any action from the user.

If the relative humidity of the ambient air is high and the outdoor temperature is very low, moisture may condense on the unit surface. This does not require any action from the user. The possibility of condensation should always be taken into account when selecting the furnishings and fixtures to be placed close to the unit.

Avoid mounting the ventilation unit to a hollow partition wall or a bedroom wall, or prevent the conduction of noise through the wall.

! NOTE:

The whole length of the outdoor air duct to the unit and the exhaust air duct from the unit must be insulated using closed-cell insulation. Closed-cell insulation is needed for the duct component that runs through warm spaces.

! NOTE:

The ventilation unit must be installed so that it can be connected to a LAN cable. The LAN cable must be able to be connected to a router.

2.1. Mounting on the floor

MyVallox 245 CFi is always mounted on the floor. Adjust the adjusting legs so that the unit is level.

! NOTE: Install the ventilation unit in a place where the temperature does not drop below +10°C.

! NOTE: When installing the unit, reserve a space of at least 800 mm in front of the unit for servicing purposes.

! IMPORTANT: If the power cord is damaged, the manufacturer, its service representative or other person with similar qualifications must replace it to avoid danger.

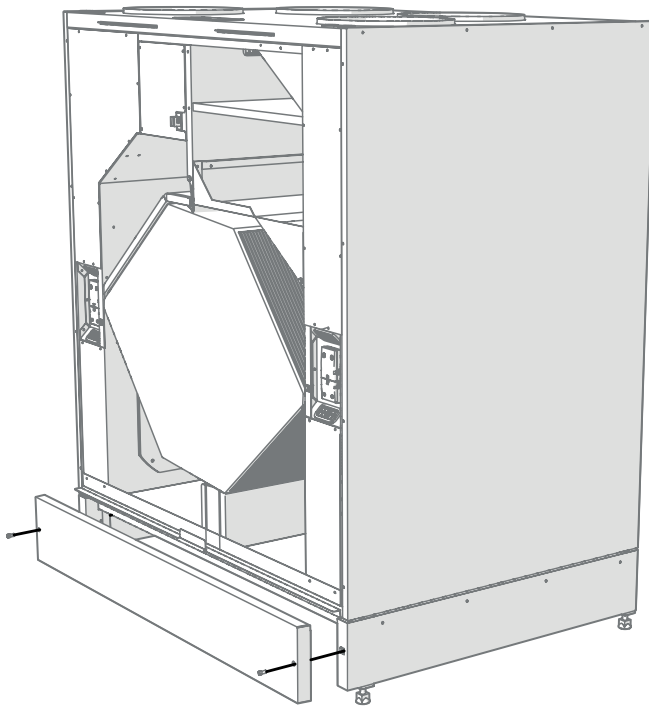

2.2. Removal of condensing water

The Vallox Silent Klick water seal package is delivered with the unit. Installation instructions for the siphon are enclosed with the Vallox Silent Klick siphon package, and can also be found online at <https://www.vallox.com>.

! NOTE: To install the siphon, remove the front panel of the base by undoing the two hexagon screws.

! WARNING:
Water must at all times be kept out of the electrical system.

3. VENTILATION UNIT CONTROL OPTIONS

The Vallox ventilation unit can be controlled by the following means:

- Through the MyVallox control panel installed to the building
- Through the MyVallox Home LAN connection and the MyVallox Home/Cloud user interface
- Through the MyVallox Cloud service and the MyVallox Home/Cloud user interface
- Through a remote monitoring or building automation system that uses voltage signals or Modbus messages.

The ventilation unit's integrated humidity and carbon dioxide sensors control ventilation automatically, as necessary. Ventilation can also be adjusted automatically by using an optional carbon dioxide, humidity, or VOC (air quality) sensor. When these sensors are used, ventilation remains optimal even when the apartment is unoccupied. The standard equipment and available optional accessories vary from country to country.

Each user can use the week clock to adjust the ventilation to fit their lifestyle and schedule.

TIP:

The MyVallox control panel automatically switches to the sleep mode when the pre-set **Sleep time** has elapsed. To reactivate the MyVallox control panel, press any button.

3.1. Connecting the ventilation unit to the cloud service

You can connect the ventilation unit to the MyVallox Cloud service. In the cloud service, you can control ventilation remotely with a smartphone or tablet, for example. The unit software is updated automatically through the cloud service. To connect to the cloud service, the ventilation unit must be connected to the internet through LAN and registered for the cloud service. By registering the unit, you create a MyVallox Cloud account for yourself. Read more about the service at <https://cloud.vallox.com>.

To register a Vallox ventilation unit with the MyVallox Cloud service:

1. Connect one end of the network cable to the grey connector of the Vallox ventilation unit and the other end to the router.
2. Open the computer's network settings by selecting **Start** → **My Computer** → **Network**. You can see a computer icon with the text Vallox and a series of numbers. Open the MyVallox Home user interface by double clicking on the icon. The MyVallox Home user interface opens.

OR

Select on the MyVallox control panel **Service menu** → **Diagnostics display** → **IP address**. Type in the IP address and press Enter. The MyVallox Home user interface opens.

3. Select Special functions.
4. The MyVallox Cloud area will open and you can see whether you are signed in to the cloud service.
5. Select **Connect**.
6. The registration page of the MyVallox Cloud cloud service opens, **Ventilation unit ID** i.e. the unique identification number of the unit will be automatically generated into the field.
7. Enter the following information in the form:
 - **Ventilation unit name** - Enter the ventilation unit name of your choice in this field.
 - **Language** - Select the desired language from the menu.
 - **Country** - Select the desired country from the menu.
 - **Choose username** - Enter the username of your choice in this field.
 - **Email** - Enter the email address of your choice in this field.
 - **Password** - Enter the password of your choice in this field.
 - **Retype your password** - Retype your password in this field.
8. Select the **I want to receive notifications related to my ventilation unit** box if you wish to receive email notifications related to your ventilation unit.
9. Read the terms and conditions of use of the service and select **I have read and accepted the terms and conditions of use of the MyVallox Cloud cloud service**. The use of the service requires that the user has accepted the terms and conditions.
10. Select **Create MyVallox Cloud account**. The ventilation unit generates a unique identification code and sends it to the service. The service will remember the unit the next time you sign into the cloud service.
11. A confirmation message will be sent to your email address. Click on the link in the message to confirm your email address and to sign in to the cloud service for the first time.
12. Once you have signed in, the MyVallox Cloud service will open and the main page of the MyVallox Cloud account will be displayed in your browser.

3.2. Connecting the ventilation unit to a computer

To use a computer as a second controller alongside the MyVallox control panel, connect the computer directly to the Vallox ventilation unit.

Before starting, ensure that you have:

- A computer with a browser that supports Web Sockets data transmission. Supported browsers:
 - Firefox, version 31 or higher.
 - Internet Explorer, version 10 or higher.
 - Opera, version 25 or higher.
 - Chrome, version 31 or higher.

- Safari, version 7 or higher.
- An internet connection to the Vallox ventilation unit with a network cable (RJ-45).

To use the Vallox ventilation unit through the MyVallox Home user interface:

1. Start the computer.
2. Connect one end of the network cable to the computer's Ethernet port and the other end to the grey Ethernet port of the Vallox ventilation unit.

! NOTE:

You can also connect the Vallox ventilation unit to a router. In that case, the Vallox ventilation unit can be connected to the MyVallox Cloud service. You can also use a WLAN network by connecting the Vallox ventilation unit to a computer.

3. On the computer, select: **Start** → **My Computer** → **Network**.
4. Please wait until you see a computer icon with the text **Vallox** and a series of numbers. Double-click on the icon to open the MyVallox Home user interface in your browser. The ventilation unit is now connected to the computer.

OR

You can skip steps 3 and 4 and:

- a. Select on the MyVallox control panel **Service menu** → **Unit information** → **IP address**. The MyVallox Home user interface opens in your browser.
- b. Type in the IP address and press **Enter**

3.3. Registering the ventilation unit in the MyVallox Cloud service

This section explains how to register the Vallox ventilation unit in the MyVallox Cloud service.

When the ventilation unit is connected to the MyVallox Cloud service, you can control ventilation remotely with a smartphone or tablet, for example. The unit software is updated automatically through the cloud service. To connect to the cloud service, the ventilation unit must be connected to the internet through LAN and registered for the cloud service. By registering the unit, you create a MyVallox Cloud account for yourself.

To register a Vallox ventilation unit with the MyVallox Cloud service:

1. Connect one end of the network cable to the grey connector of the Vallox ventilation unit and the other end to the router's LAN port (usually numbered 1,2,3,4). The LAN port must not be bridged, i.e. it must share private IP addresses (addresses that begin with 10.x.x.x, 172.x.x.x or 192.168.x.x).

TIP:

If the ventilation unit rejects the IP address and it is not possible to connect the unit to the intranet, go to the router settings and make sure the DHCP server is on and it is sharing private IP addresses (addresses that begin with 10.x.x.x, 172.x.x.x or 192.168.x.x).

2. Open the computer's network settings by selecting **Start** → **My Computer** → **Network**. You can see a computer icon with the text **Vallox** and a series of numbers.

OR

Select on the MyVallox Control control panel **Service menu** → **Unit information** → **IP address**. Type in the IP address and press **Enter**.

3. Open the MyVallox Home user interface by double-clicking on the icon.

4. Select **Special functions**. 
5. Under **Cloud service**, you can see whether you are signed in to the MyVallox Cloud service.

Cloud service

You are not signed in into the MyVallox Cloud cloud service.

Connect

6. Select **Connect**.
7. The registration page of the MyVallox Cloud service opens. The **Ventilation unit ID**, i.e. the unit's unique identifier, is generated automatically in the field.

Register your Vallox ventilation unit to start using the service

I already have an account: [Log in](#)

Ventilation unit ID:
 *

Ventilation unit name:
 *

Language:
 *

Country:
 *

Email:
 *

Password:
 *

I want to receive notifications related to my ventilation unit:

[I have read and accepted the terms and conditions of use of the MyVallox Cloud cloud service:](#)

[Create MyVallox Cloud account](#)

8. Enter the following information in the form:
 - **Ventilation unit name** — Enter the ventilation unit name of your choice in this field.
 - **Language** — Select the desired language.
 - **Country** — Select the desired country.
 - **Email** — Enter your email address in this field. The email address is your username.
 - **Password** — Enter the password of your choice in this field.
9. Select the **I want to receive notifications related to my ventilation unit** box if you wish to receive notifications related to your ventilation unit.
10. Select **I have read and accepted the terms and conditions of use of the MyVallox Cloud cloud service** and read the terms and conditions of use of the service. The use of the service requires that the user has accepted the terms and conditions.
11. Select **Create MyVallox Cloud account**. The ventilation unit generates a unique identification code and sends it to the service. The service will remember the unit the next time you sign into the cloud service.

-
12. A confirmation message will be sent to your email address. Click on the link in the message to confirm your email address and to sign in to the cloud service for the first time.
 13. Once you have signed in, the MyVallox Cloud service will open and the main page of the MyVallox Cloud account will appear in your browser.

My devices

[Demo Machine](#)

Last seen:

--

Device ID:

8853824E-C597-4ECC-BDC0-9C23DCC6344F



4. MAINTENANCE

This section describes the maintenance of the Vallox ventilation unit.

⚠ WARNING: The safety switch automatically turns off the power when the upper door of the Vallox ventilation unit is opened. **Always disconnect** the Vallox ventilation unit from the mains before starting maintenance.

⚠ WARNING:
If you are using water to clean unit parts, be careful that the water does not touch the electrical parts.

! IMPORTANT:
If the power cord is damaged, the manufacturer, its service representative or other person with similar qualifications must replace it to avoid danger.

! NOTE:
Vallox ventilation units are available in two models: a left-handed (L) and a right-handed (R) model. The images below depict the right-handed model.
In the right-handed model, outdoor air enters the unit from the right side of the centre line, as shown in these instructions. In the left-handed model, outdoor air enters the unit from the left. Correspondingly, the placement of the filters, HR cell bypass damper and heating resistor is reversed.

The table below indicates the recommended maintenance intervals for different Vallox ventilation unit parts.

Table 1. Recommended maintenance intervals for Vallox ventilation unit parts

Part	Year 1				Year 2			
	Spring	Summer	Autumn	Winter	Spring	Summer	Autumn	Winter
Filters	x		x		x		x	
Cell								x
Fans	x		x		x		x	
Siphon			x					x
General cleaning and visual check			x					x

4.1. Opening and closing the doors

1. Turn the latches to open the upper door of the ventilation unit.

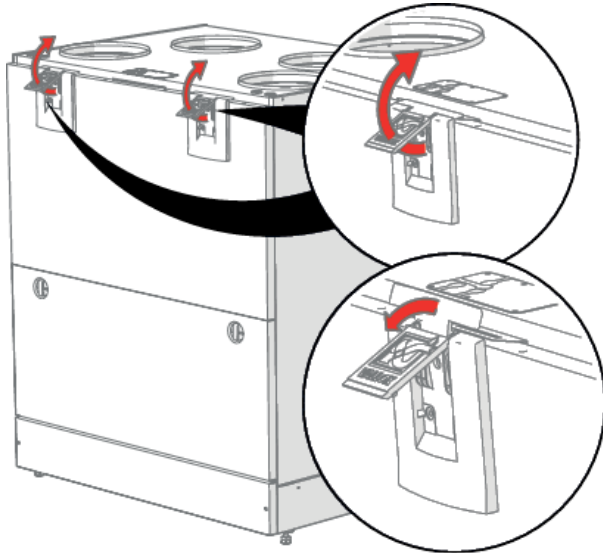

2. Lift the upper door off.

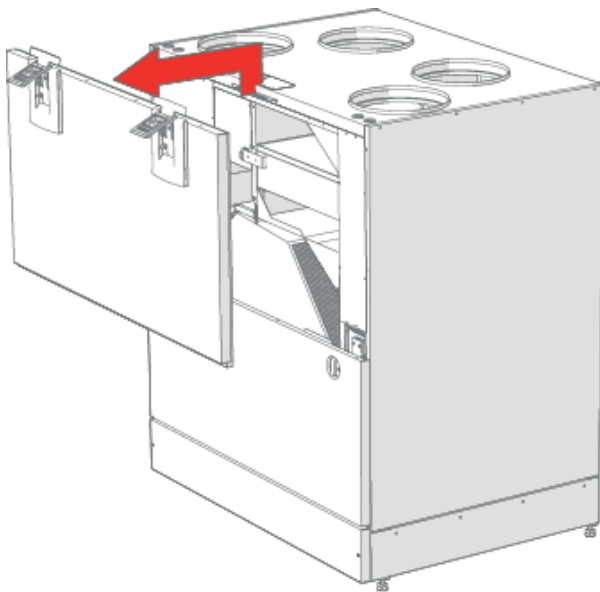

⚠ CAUTION: The door is heavy.

3. Open the lower door of the ventilation unit by undoing the finger screws.

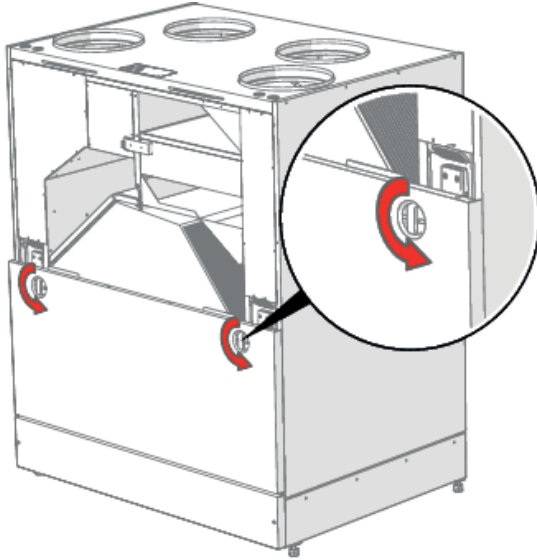

4. Lift the lower door off.

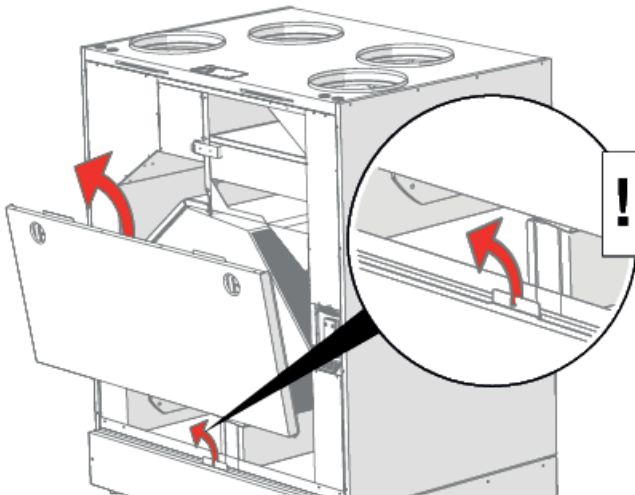

⚠ CAUTION: The door is heavy.

5. Close the doors in reverse order.

There are two unit models, left- (L) and right-handed (R). The figure shows the right-handed model.

4.2. Changing the filters

⚠ WARNING: The safety switch automatically turns off the power when the upper door of the Vallox ventilation unit is opened. **Always disconnect** the Vallox ventilation unit from the mains before starting maintenance.

When the maintenance reminder becomes activated, check the cleanliness of the filters and replace them if required.

The Vallox ventilation unit has three air filters:

- Coarse filter for supply air filters insects, heavy pollen and other relatively large foreign objects out of the outdoor air.
- Fine filter for supply air filters microscopic pollen and dust particles out of the supply air.
- Coarse filter for extract air filters the extract air and keeps the heat recovery cell clean.

The filter replacement interval depends on the ambient particle concentration. It is recommended that the filters be replaced every spring and autumn, or, at the very least, once a year.

! NOTE:

Using original Vallox filters ensures that the ventilation unit remains in top condition, giving the best results. Selection and ordering of filter packages: filters.vallox.com

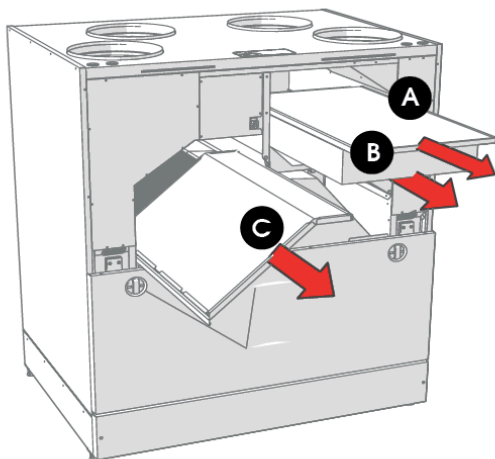

To replace the filters:

1. Disconnect the ventilation unit from the mains electricity supply.
2. Open the upper door of the unit.
3. Remove the old filters (**A, B, C**) and discard them.
4. Install the new filters (**A, B, C**).

5. Close the door of the unit. Ensure that the safety switch catch of the door is touching the safety switch, allowing the unit to be turned on.
6. Plug the ventilation unit back into the mains.

The filters have now been successfully replaced.

4.3. Cleaning the heat recovery cell

⚠ WARNING: The safety switch automatically turns off the power when the upper door of the Vallox ventilation unit is opened. **Always disconnect** the Vallox ventilation unit from the mains before starting maintenance.

Check that the heat recovery cell is clean roughly once a year, or whenever the filters are being replaced. Clean by washing as required.

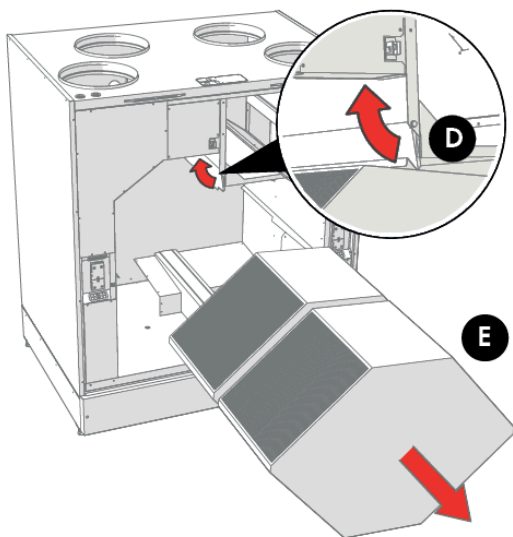

To check and clean the heat recovery cells:

1. Disconnect the ventilation unit from the mains electricity supply.
2. Open the doors of the unit.
3. Remove the filters (A, B, C). See [Changing the filters](#).
4. Remove the support grid of the filters.
5. Disengage the upper support strip (D) of the cell.
6. Lift and pull the cell (E) out of the unit.

⚠ IMPORTANT: Handle the cells carefully! For example, do not lift the cells by the layers. The cell layers are very thin and easily damaged.

7. If the cell is dirty, clean it by immersing it in warm water, to which a small amount of a mild detergent has been added.
8. Rinse the cell clean with a water spray. Do not use a high-pressure cleaner.
9. When all the water has drained from between the layers, reassemble the ventilation unit in the reverse order.
10. Close the doors. Ensure that the safety switch catch of the door is touching the safety switch.
11. Plug the ventilation unit back into the mains.

The heat recovery cells have now been checked and cleaned.

4.4. Cleaning the fans

⚠ WARNING: The safety switch automatically turns off the power when the upper door of the Vallox ventilation unit is opened. **Always disconnect** the Vallox ventilation unit from the mains before starting maintenance.

Check the cleanliness of the fans when servicing the filters and the heat recovery cell. Clean the fans as required.

You can clean the fan blades with compressed air (wear protective goggles) or by brushing them gently.

! IMPORTANT: The fans are extremely sensitive to external shocks. It is recommended that the fans be cleaned in place, i.e. without attempting to remove them.

! IMPORTANT: Handle the fan blades carefully. Do not remove or move the fan blade balancing weights.

! NOTE:
Only the supply air fan is equipped with a sound-damping grille.

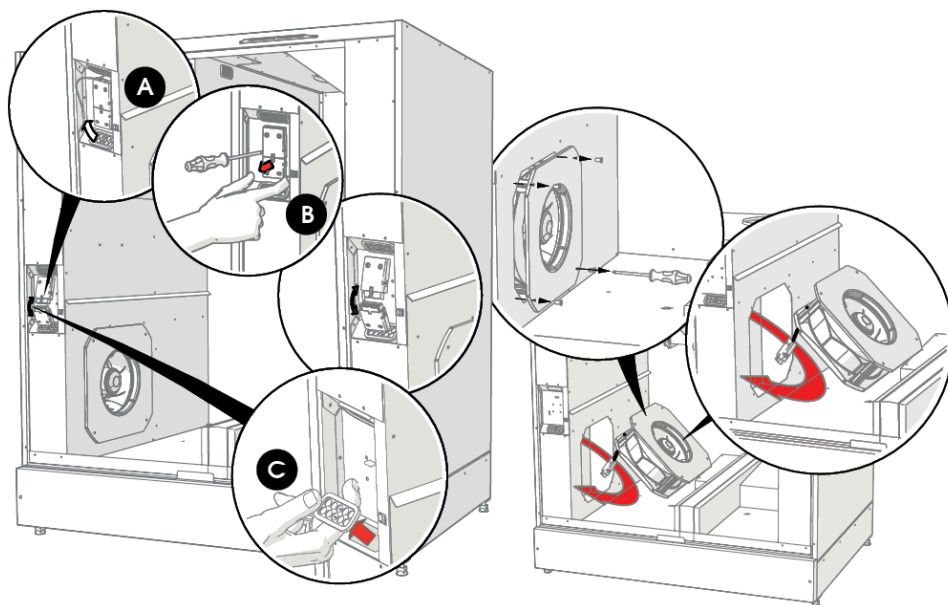

To clean the supply air fan:

1. Disconnect the ventilation unit from the mains electricity supply.
2. Open the doors of the unit.
3. Pull the temperature sensor out of the rubber feed through **(A)**.
4. Disconnect the quick connector **(B)** of the fan cables.
5. Remove the rubber feed through **(C)**.
6. Undo the fan's mounting screws.
7. Pull the fan out of its housing.
8. Clean the fan.
9. To reassemble the ventilation unit, follow the above steps in reverse order.

! NOTE:

Remember to replace the temperature sensor by feeding it through the rubber feed.

10. Close the doors. Ensure that the safety switch catch of the door is touching the safety switch.
11. Plug the ventilation unit back into the mains.

The fan has now been checked and cleaned.

Clean the extract air fan in the same way. The extract air fan is located symmetrically on the opposite side of the unit.

Cleaning the anemometer

The anemometer in the fan must be cleaned at least every three (3) years. It is recommended to

use compressed air (max 2–3 bar) for the cleaning.

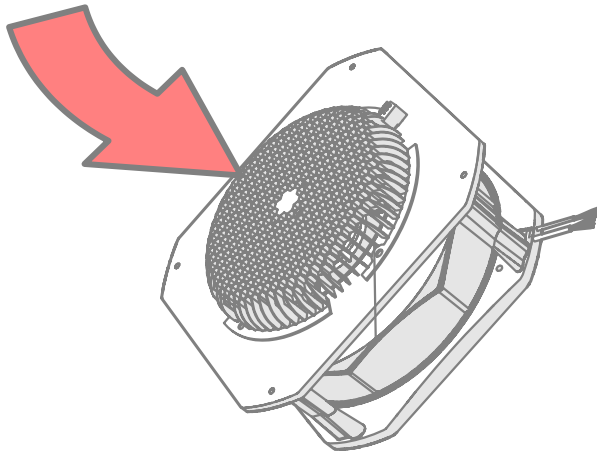

! IMPORTANT:

When using compressed air, the arms of the anemometer must not be allowed to freely. This could damage the bearings.

! IMPORTANT:

Cleaning with a brush is not recommended. This could damage the arms.

4.5. Removing the resistor

! WARNING: The safety switch automatically turns off the power when the upper door of the Vallox ventilation unit is opened. **Always disconnect** the Vallox ventilation unit from the mains before starting maintenance.

To remove the resistor:

1. Disconnect the ventilation unit from the mains electricity supply.
2. Open the doors of the unit.

3. Open the resistor box by undoing the mounting screws (10 PZ2 screws).

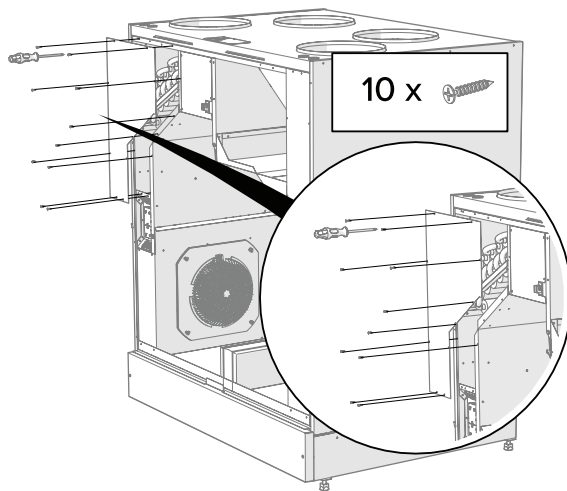

4. Remove the quick connector of the resistor:
 - a. Press down the locking device.
 - b. Pull off the connector.

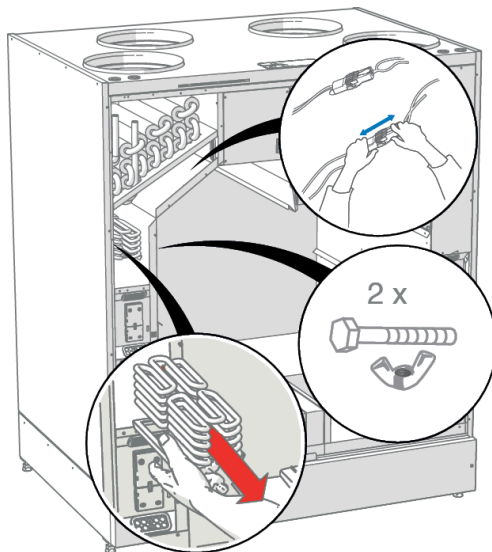

5. Undo the two wing nuts connecting the resistor to the ventilation unit.
6. Lift the resistor out of the ventilation unit.

⚠ WARNING:

Before removing the resistor from the unit, make sure it is not hot.

7. To reassemble the ventilation unit, follow the above steps in reverse order.

⚠ WARNING:

Risk of fire! Connect the cables so that they do not touch the resistor.

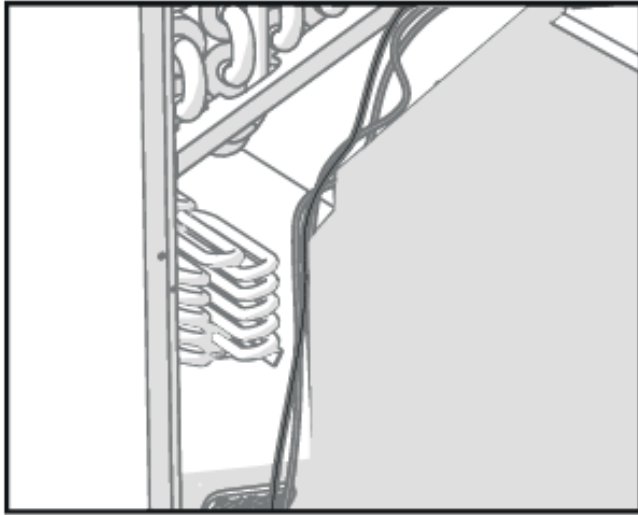

4.6. Condensing water

In the heating season, the extract air humidity condenses to water. In new buildings, condensation runoff can form rapidly. Condensed water must be able to freely leave the unit.

! NOTE:

Some condensing water may have accumulated in the bottom pool of the unit; this is normal and requires no corrective action.

At some time before the heating season begins (e.g. during autumn maintenance), check that the siphon or the condensing water outlet in the bottom pool are not clogged. To check this, pour some water into the pool. Clean as required.

⚠ WARNING:

Water must at all times be kept out of the electrical system.

4.7. Updating the unit software (MyVallox Control)

To update the ventilation unit software through the MyVallox Control panel:

1. Download the latest update package to your computer from the home page of the MyVallox Cloud service <https://cloud.vallox.com>. You can find the latest update under Latest firmware version .

! NOTE: The name of the update file must always be the same: HSWUPD.BIN. If you have downloaded an older update file to your computer, delete it before downloading the new update to make sure the file name does not change.

2. Connect the computer to the ventilation unit control panel with a USB Micro-B connector.

! NOTE:

- The MyVallox control panel cannot be used when it is connected to the computer. A USB icon is shown on the control panel.
- If the computer is unable to find the ventilation unit, you are probably using a charging cable. Try another USB Micro-B cable.

3. When the ventilation unit is turned on, the control panel appears as an external drive in the computer's resource management.
4. Copy the new update package HSWUPD.BIN and paste it to the control panel, i.e. the root of the external drive.

! IMPORTANT: Do not change the file name.

5. Make sure the update package has been completely transferred to the control panel by selecting Safely Remove USB. This is an OS-specific function.
6. Disconnect the USB cable.
7. The control panel loads the update for a moment (you can see the process on the panel) and starts to transfer the update package to the ventilation unit in the background. This takes approximately 4–5 hours.
8. When the update is complete, the unit launches the new software and restarts itself automatically.

! NOTE: The ventilation unit must stay on throughout the update process. If the ventilation unit's power is cut off during the process, the transfer time of 4–5 hours starts from the beginning.

! NOTE: If a red error screen appears on the control panel, the update must be downloaded again. Go back to step 1.

When the update is complete, the software version shown on the **Unit information** screen should be the same as the version at <https://cloud.vallox.com>.

4.8. Troubleshooting

The table below provides instructions for troubleshooting and repair.

! IMPORTANT:

We recommend you always use the latest software version. You can check the latest version at <https://cloud.vallox.com>.

! NOTE:

Error messages are displayed on the control panel and in the MyVallox Home and MyVallox Cloud services.

Error	Cause	Follow these steps
Error message: Extract air fan	The extract air fan has stopped.	Make sure the fan has really stopped. Check the fan wires and operation. If necessary, the fan must be replaced. Contact the service centre.
Error message: Supply air fan	The supply air fan has stopped.	Make sure the fan has really stopped. Check the fan wires and operation. If necessary, the fan must be replaced. Contact the service centre.
Error message: Temperature sensor 1/2/3/4/5	A temperature sensor indicated by the user interface is damaged.	Check the sensor installation. If necessary, the sensor must be replaced. Contact the service centre.
Error message: High supply air temperature	The supply air temperature is too high.	Check the operation of the post-heating and additional heating resistors. Make sure the resistors are on in the user interface. If necessary, contact the service centre.
Error message: Low supply air temperature	The supply air temperature is too low.	Check the operation of the post-heating and additional heating resistors. Make sure the resistors are on in the user interface. If necessary, contact the service centre.
Error message: Bus error	Problems in data transmission.	Make sure that the control panel and any external sensors are connected and working correctly.
Both the ventilation unit and the control panel do not work.	The unit's power supply has been cut off or the safety switch pusher on the door does not touch the safety switch.	Check: <ul style="list-style-type: none"> • Fuse on the fuse panel • The unit's glass tube fuse. Contact the service centre. • Push in the safety switch and check does the unit start up. If the unit starts up, make sure the safety switch pusher on the door is pressing on the safety switch.
The ventilation unit works but the control panel does not work.	The control panel's 24 VDC supply has been cut off, there are problems in data transmission or the control panel is damaged.	<ul style="list-style-type: none"> • Check the cords between the unit and the control panel. • Unplug the unit and restart the unit. • Update the unit software. • Contact the service centre.

5. TECHNICAL SPECIFICATIONS

Table 2. Technical specifications MyVallox 245 CFi, aluminium

Object	MyVallox 245 CFi
Product titles	MyVallox 245 CFi R MyVallox 245 CFi L
Type code	3734
Electrical connection	230 V, 50 Hz, 15.2 A power plug
Enclosure protection class	IP34
Fans	<ul style="list-style-type: none"> • Supply air — 0.17 kW 1.25 A EC • Extract air — 0.17 kW 1.25 A EC
Air volumes	<ul style="list-style-type: none"> • Supply air — 226 dm³/s, 100 Pa • Extract air — 226 dm³/s, 100 Pa
Heat recovery bypass	Automatic
Post-heating	Electrical resistor, 1500 W
Pre-heating	-
Additional heating	Electrical resistor, 1500 W
Filters	<ul style="list-style-type: none"> • Supply air — ISO Coarse > 75% + ISO ePM₁ ≥ 50 % • Extract air — ISO Coarse > 75%
Specific energy consumption (SEC)	In a cold climate — A+ Temperate climate — A+
Efficiencies*	<ul style="list-style-type: none"> • Annual efficiency — 83% • Supply air efficiency — 87% • Specific Fan Power (SFP) — 0.63 kW/m³/s (160 dm³/s)
Dimensions (w × h × d)	1038 x 1241 x 773 mm
Weight	181 kg

*Working point defined in the Ecodesign Directive (2009/125/EC), Southern Finland, Helsinki-Vantaa TRY year 2020.

Table 3. Technical specifications MyVallox 245 CFi, enthalpy

Object	MyVallox 245 CFi enthalpy
Product titles	MyVallox 245 CFi R enthalpy MyVallox 245 CFi L enthalpy
Type code	3735
Electrical connection	230 V, 50 Hz, 15.2 A power plug
Enclosure protection class	IP34
Fans	<ul style="list-style-type: none"> • Supply air — 0.170 kW 1.25 A EC • Extract air — 0.170 kW 1.25 A EC
Air volumes	<ul style="list-style-type: none"> • Supply air — 229 dm³/s, 100 Pa • Extract air — 229 dm³/s, 100 Pa
Heat recovery bypass	Automatic
Post-heating	Electrical resistor, 1500 W
Pre-heating	-
Additional heating	Electrical resistor, 1500 W
Filters	<ul style="list-style-type: none"> • Supply air — ISO Coarse > 75% + ISO ePM₁ ≥ 50 % • Extract air — ISO Coarse > 75%
Specific energy consumption (SEC)	In a cold climate — A+ Temperate climate — A+
Efficiencies*	<ul style="list-style-type: none"> • Supply air efficiency — 86% • Specific Fan Power (SFP) — 0.57 kW/m³/s (160 dm³/s)
Dimensions (w × h × d)	1038 × 1241 × 773 mm
Weight	178.5 kg

*Working point defined in the Ecodesign Directive (2009/125/EC), Southern Finland, Helsinki-Vantaa TRY year 2020.

Table 4. Technical specifications MyVallox 245 CFi VKL

Object	MyVallox 245 CFi VKL
Product titles	MyVallox 245 CFi VKL R MyVallox 245 CFi VKL L
Type code	3734
Electrical connection	230 V, 50 Hz, 15.2 A power plug
Enclosure protection class	IP34
Fans	<ul style="list-style-type: none"> • Supply air — 0.170 kW 1.25 A EC • Extract air — 0.170 kW 1.25 A EC
Air volumes	<ul style="list-style-type: none"> • Supply air — 226 dm³/s, 100 Pa • Extract air — 227 dm³/s, 100 Pa
Heat recovery bypass	Automatic
Post-heating	Liquid radiator
Pre-heating	-
Additional heating	Electrical resistor, 3000 W
Filters	<ul style="list-style-type: none"> • Supply air — ISO Coarse > 75% + ISO ePM₁ ≥ 50 % • Extract air — ISO Coarse > 75%
Specific energy consumption (SEC)	In a cold climate — A+ Temperate climate — A+
Efficiencies*	<ul style="list-style-type: none"> • Annual efficiency — 83% • Supply air efficiency — 87% • Specific Fan Power (SFP) — 0.68 kW/m³/s (158 dm³/s)
Dimensions (w × h × d)	1038 x 1241 x 773 mm
Weight	187 kg

*Working point defined in the Ecodesign Directive (2009/125/EC), Southern Finland, Helsinki-Vantaa TRY year 2020.

5.1. Supply/extract air volumes and input powers

Figure 1. Fan supply and extract air volumes, aluminium heat recovery cell

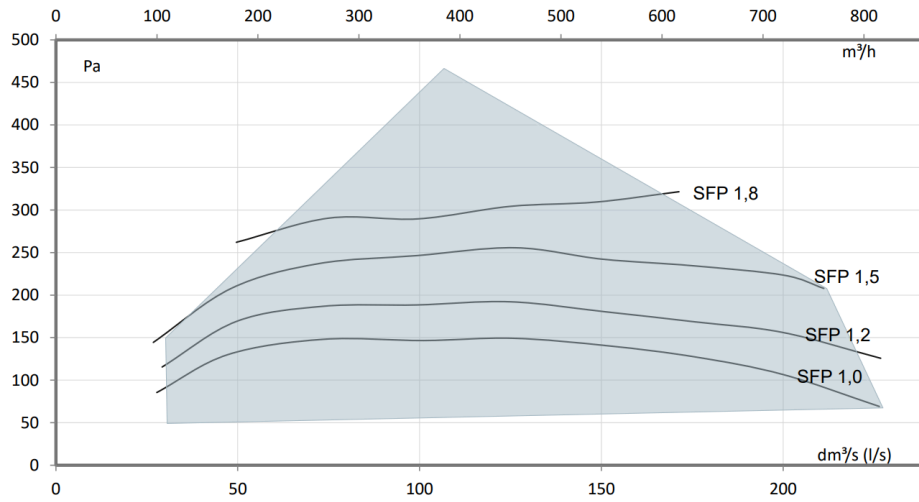

Figure 2. Fan supply and extract air volumes, enthalpy heat recovery cell

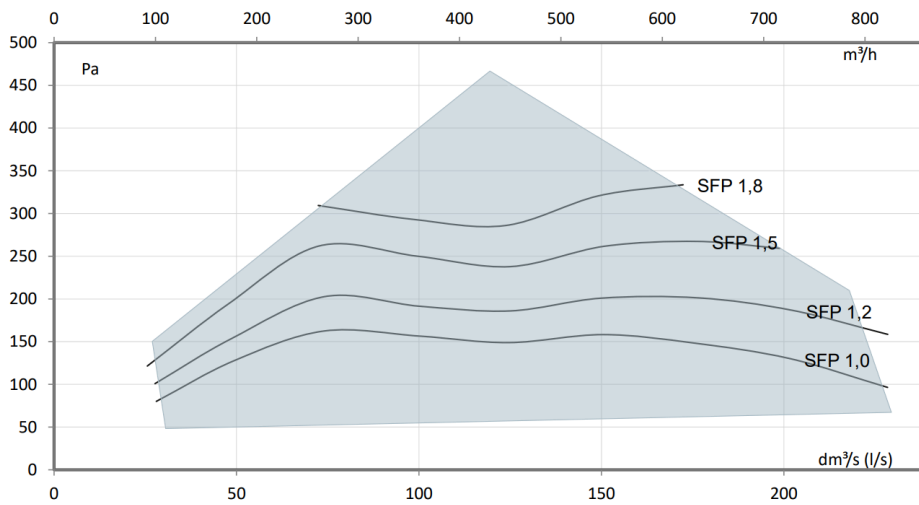
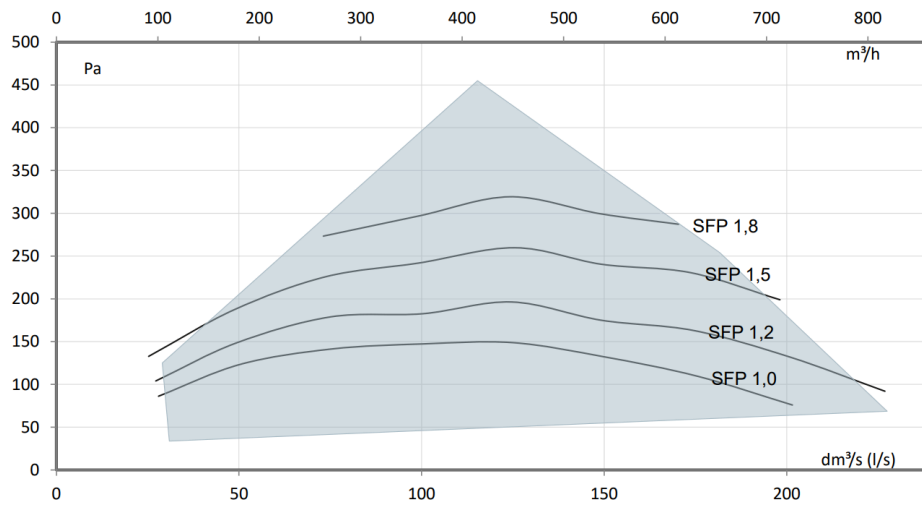

Figure 3. Fan supply and extract air volumes, MyVallox 245 CFi VKL



$$SFP = \frac{\text{Input power (total) (W)}}{\text{Air flow (max) (dm}^3/\text{s)}}$$

The recommended SFP (Specific Fan Power) rate is <math><1.8 \text{ (kW m}^3/\text{s)}</math>. At a lower total pressure, the SFP rate is lower.

Table 5. Input power, aluminium heat recovery cell

	l/s	m ³ /h	Pa	W
Min	30	107	102	35
Mid	125	450	192	149
Max	211	760	208	316

Table 6. Input power, enthalpy heat recovery cell

	l/s	m ³ /h	Pa	W
Min	29	105	75	22
Mid	126	452	165	135
Max	217	782	210	311

Table 7. Input power, MyVallox 245 CFi VKL

	l/s	m ³ /h	Pa	W
Min	30	107	82	25
Mid	125	450	169	142
Max	181	651	254	313

You can calculate the operating-point-specific input power with the *Vallox MySelecta* product selection program.

5.2. Sound values

Sound power level in the supply air duct (one duct) by octave band L_W dB										
Air flow l/s		30	50	75	100	125	150	175	200	225
Medium frequency of the octave band Hz	63	56	60	65	67	70	74	75	78	79
	125	46	51	60	69	74	74	76	77	76
	250	36	46	52	57	67	72	74	76	77
	500	30	39	49	53	58	61	65	68	68
	1000	23	35	43	49	54	58	62	65	65
	2000	19	30	40	47	52	56	60	63	63
	4000	17	18	26	35	42	47	51	55	56
	8000	22	22	22	25	32	38	43	47	48
L_W dB		57	60	66	72	76	78	80	82	83
L_{WA} dB(A)		35	43	51	57	63	67	70	72	73

Sound power level in the extract air duct (one duct) by octave band L_W dB										
Air flow l/s		30	50	75	100	125	150	175	200	225
Medium frequency of the octave band Hz	63	45	51	53	57	61	64	67	69	70
	125	37	39	51	57	54	56	58	60	60
	250	35	36	43	47	53	63	61	65	66
	500	20	25	31	35	39	43	46	48	49
	1000	11	18	27	33	37	41	44	49	50
	2000	13	14	20	27	32	36	40	43	44
	4000	17	16	17	18	22	26	31	34	36
	8000	22	22	22	22	22	22	23	25	26
L_W dB		46	52	56	60	62	67	69	71	72
L_{WA} dB(A)		30	32	39	44	47	55	54	58	59

Sound pressure level coming through the envelope of the unit in the room in which it is installed (10 m ² sound absorption)										
Air flow l/s		30	50	75	100	125	150	175	200	225
L_{pA} dB (A)		23	23	28	34	39	42	45	49	48

The operating-point-specific sound values can be calculated with the *Vallox MySelecta* product selection program.

5. Supply air from the HR cell

D	LAN	RM/O	24 V relay output
MB_A	External Modbus A signal	T	Supply air fan
MB_B	External Modbus B signal	P	Extract air fan
+24V	+24V voltage (DC)	M	Damper motor
GND	Digital and analog ground potential	TK	Safety switch
RS_A	Local hardware Modbus A signal	AHS	Air flow measuring sensor for extract air fan
RS_B	Local hardware Modbus B signal	%RH	Air flow measuring sensor for supply air fan
NTC	External temperature sensor connector	%RH CO₂	Internal humidity and carbon dioxide sensor
D/I1	Digital input 1	R1	Post-heating resistor with 90°C and 130°C overheating protection
D/I2	Digital input 2	R2	Additional heating resistor with 90°C and 130°C overheating protection

Table 8. Cable colours

Code	Colour	Code	Colour
BK	Black	GN	Green
BU	Blue	RD	Red
BN	Brown	YE	Yellow
WT	White	YEGN	Yellow-green

5.4. Internal electrical connection MyVallox 245 CFi VKL

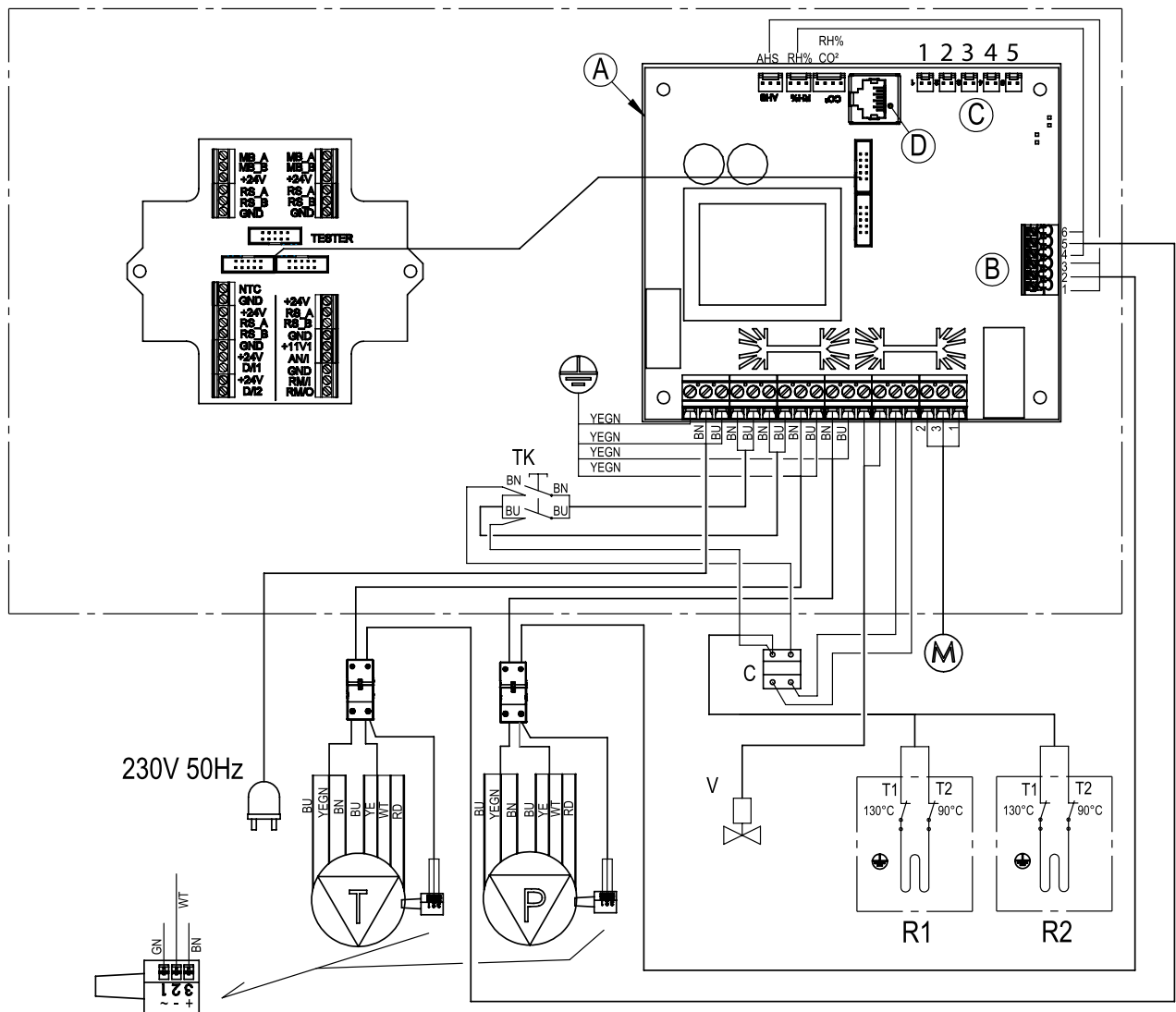

A Motherboard **AN/I** Analog input 0–10 VDC

- B**
1. Extract air fan tachometer (WT)
 2. GND (GN)
 3. Extract air fan PWM (YE)
 4. Supply air fan tachometer (WT)
 5. GND (GN)
 6. Supply air fan PWM (YE)

RM/I 24 V relay input

C

1. Extract air
2. Outdoor air
3. Supply air
4. Exhaust air

RM/O 24 V relay output

5. Supply air from the HR cell

D	LAN	V	Liquid radiator actuator
MB_A	External Modbus A signal	T	Supply air fan
MB_B	External Modbus B signal	P	Extract air fan
+24V	+24V voltage (DC)	M	Damper motor
GND	Digital and analog ground potential	TK	Safety switch
RS_A	Local hardware Modbus A signal	C	Heating resistor relay
RS_B	Local hardware Modbus B signal	AHS	Air flow measuring sensor for extract air fan
NTC	External temperature sensor connector	%RH	Air flow measuring sensor for supply air fan
D/I1	Digital input 1	%RH CO₂	Internal humidity and carbon dioxide sensor
D/I2	Digital input 2	R1	Post-heating resistor with 90°C and 130°C overheating protection
11V1	11.1 V operating voltage	R2	Additional heating resistor with 90°C and 130°C overheating protection

Table 9. Cable colours

Code	Colour	Code	Colour
BK	Black	GN	Green
BU	Blue	RD	Red
BN	Brown	YE	Yellow
WT	White	YEGN	Yellow-green

5.5. External electrical connection

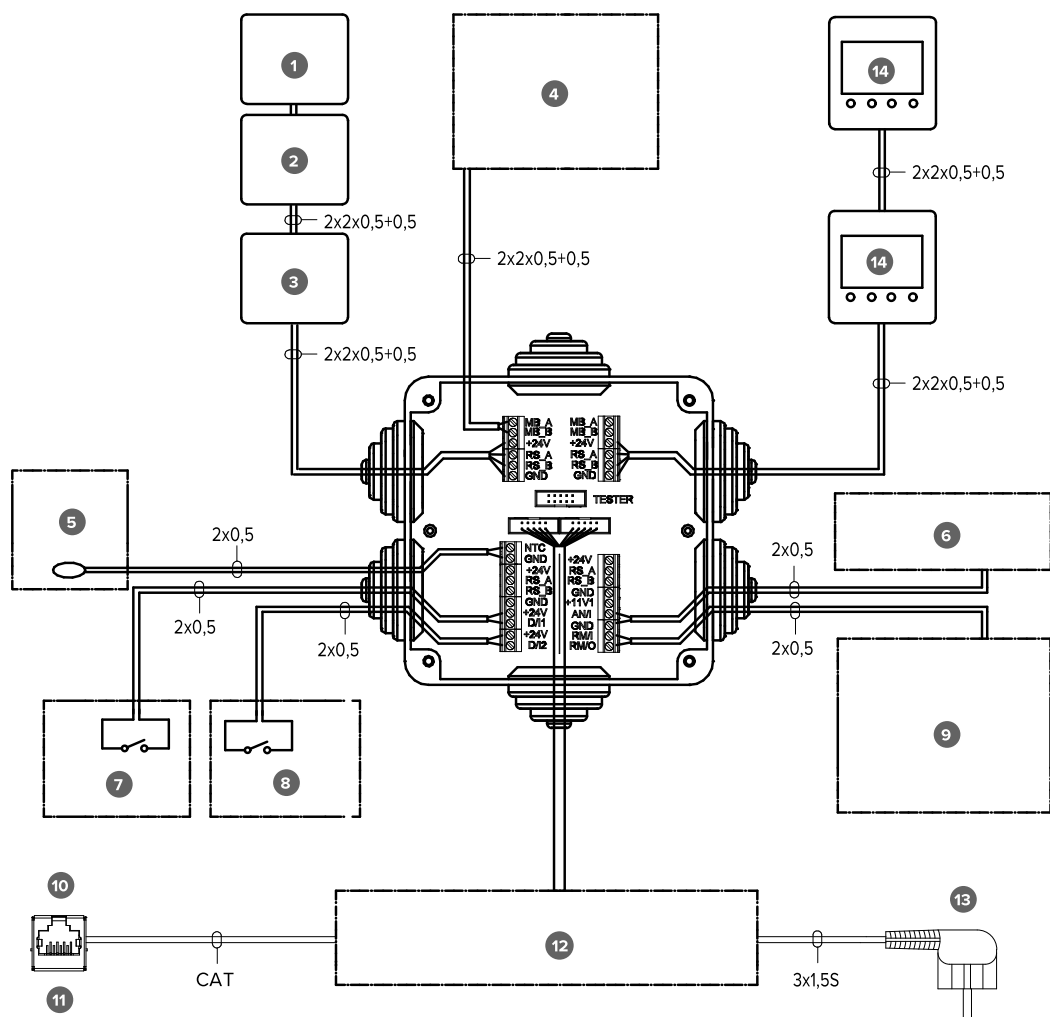

No.	Name	No.	Name
1	MyVallox VOC sensor	8	Digital input 2. 8 different functions.
2	MyVallox %RH sensor	9	Potential-free contact data 24VDC. Can be programmed to display, for example, error notifications or the HR cell's bypass status.
3	MyVallox CO ₂ sensor	10	Ethernet connection on top of the unit
4	Remote monitoring Modbus RTU	11	RJ45 female
5	External temperature sensor NTC 4K7	12	Internal connection of the ventilation unit
6	Analog input. Two separate functions.	13	Plug connection 1.2 m on top of the unit
7	Digital input 1. 8 different functions.	14	MyVallox control panel

MB_A	External Modbus A signal	D/I1	Digital input 1
MB_B	External Modbus B signal	D/I2	Digital input 2
+24V	+24 V voltage (DC)	11V1	11.1 V operating voltage
GND	Digital and analog ground potential	AN/I	Analog input 0-10 VDC
RS_A	Local hardware Modbus A signal	RM/I	24 V relay input
RS_B	Local hardware Modbus B signal	RM/O	24 V relay output
NTC	External temperature sensor connector		

Table 10. Power supply

Object	Feed
Maximum	≤6W
MyVallox Control	1 W
MyVallox Touch	0.5 W
%RH sensor	0.3 W
CO₂ sensor	1.2 W
VOC sensor	2 W
External actuator or damper motor of the unit that receives feed from the relay	
Voltage	24 VDC

5.6. External electrical connection for controlling the MLV duct radiator

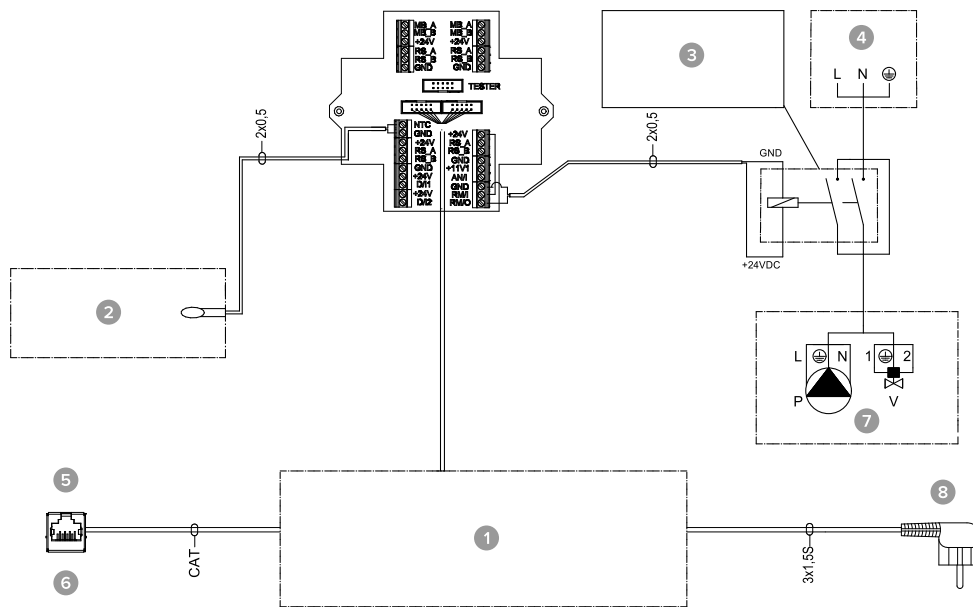

No.	Name	No.	Name
1	Internal connection of the ventilation unit	5	Ethernet connection on top of the unit
2	External temperature sensor NTC 4K7	6	RJ45 Female
3	24 VDC relay/contactor for controlling the pump and solenoid valve	7	MLV control
4	Distribution board	8	Plug connection 1.2 m on top of the unit

MB_A	External Modbus A signal	D/I2	Digital input 2
MB_B	External Modbus B signal	11V1	11.1 V operating voltage
+24V	+24 V voltage (DC)	AN/I	Analog input 0-10 VDC
GND	Digital and analog ground potential	RM/I	24 V relay input
RS_A	Local hardware Modbus A signal	RM/O	24 V relay output
RS_B	Local hardware Modbus B signal	P	Circulation pump
NTC	External temperature sensor connector	V	Solenoid valve
D/I1	Digital input 1		

5.7. Duct radiator operation

Always primarily follow the connection plan provided by the HVAC designer or heat pump manufacturer. Remember to also read the duct radiator's instructions for use.

The accompanying figure shows an example of the arrangement for connecting the heating/cooling radiator unit to the heat collection circuit.

NOTE:

If the duct radiator is used in the supply air duct, it can only be used for cooling.

The output pipe of the radiator unit is connected to the return pipe of the heat collection circuit. The liquid returning from the radiator unit is circulated back to the heat collection circuit's return pipe. If it is known that the pressure losses inside the heat collection circuit's heat pump are too great, bypassing the heat pump is recommended. In that case the liquid is circulated when the heat pump is at rest, and the pressure loss of the bypass' one-way valve Y2 must be smaller than the pressure loss of the heat pump.

Heating: The pump is switched on when the outdoor air temperature drops below the factory-set winter limit (-5°C).

Cooling: The target supply air temperature set for the unit's mode (e.g. At Home mode) determines when the pump is switched on. The pump is switched on when the supply air setting is lower than the temperature of the air supplied.

The duct radiator can be installed in the supply air duct or the outdoor air duct. If the radiator is placed in the outdoor air duct, it can be used for pre-heating and cooling. If the radiator is placed in the supply air duct, it can only be used for heating or cooling.

NOTE:

To control the outdoor air duct radiator, an external NTC sensor is installed in the outdoor air duct before the radiator. To control the supply air duct radiator, an external NTC sensor is installed after the radiator.

The duct radiator can be set to work automatically or manually.

- **Automatic operation:** In summer, the set supply air temperature is maintained. In winter, the duct radiator is switched on when the outdoor air temperature drops below the winter setting.
- **Manual operation:** In summer, the duct radiator is switched on when the outdoor air temperature rises above the summer setting. In winter, the duct radiator is switched on when the outdoor air temperature drops below the winter setting.

To prevent the risk of condensation in the supply air duct, you can set the adjustment of the supply air limit to automatic or manual.

- Automatic adjustment: The supply air limit is adjusted automatically according to the extract air dew point. When the supply air temperature drops too low, the duct radiator is switched off.
- Manual adjustment: The supply air limit is set manually. When the supply air temperature drops below the set value, the duct radiator is switched off.

If you are using an external sensor, go to the external sensor settings and select either outdoor air duct radiator or supply air duct radiator control. The external sensor's temperature reading is displayed in the maintenance menu: **Menu> > Service menu> > Unit information (page 5)> > External sensor.**

! NOTE:

When choosing the relay (C), take into account the maximum joint power supply of the motherboard of the MV electric box (max. 6 W), if the relay is supplied by the motherboard's +24 V connector.

! NOTE:

Due to the risk of humidity damage, in a duct that has not been insulated for condensation the supply air temperature must not fall below +16 ... 20 °C.

Figure 4. Duct radiator operation chart in the outdoor air duct

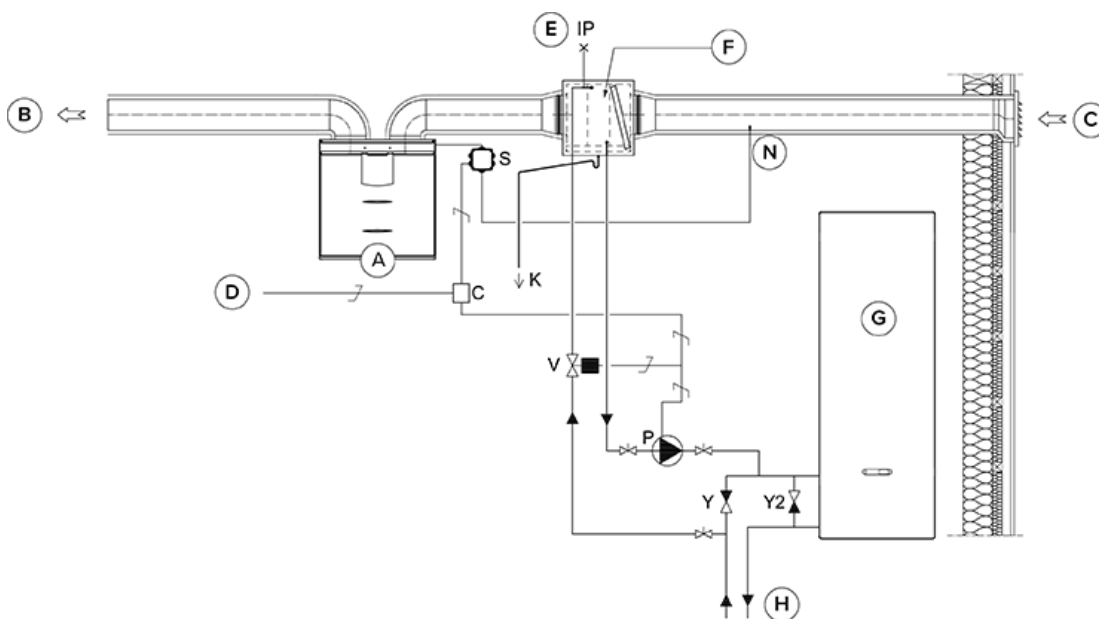
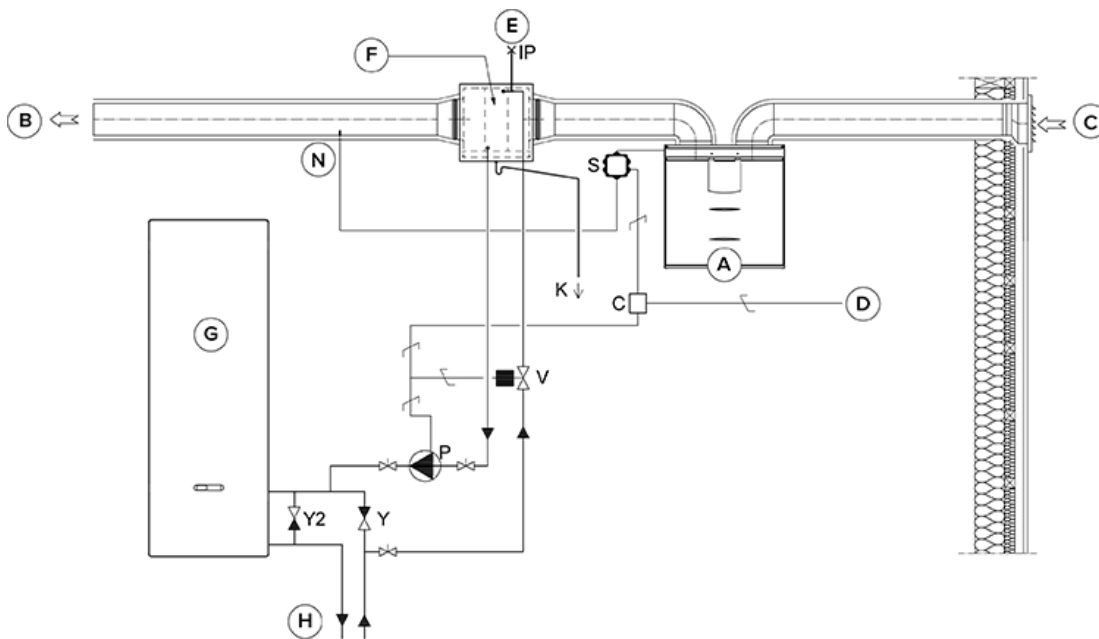

Figure 5. Duct radiator operation chart in the supply air duct



Name	Name
A Ventilation unit	P Circulation pump. Not included in delivery. Due to a risk of condensation, use a pump that is suitable for pumping liquid colder than the environment (e.g. Grundfos Magna 1 25-80).
B Supply air	V Solenoid valve. Not included in delivery. The valve should be suitable for heat collection circuit liquid (e.g. Danfoss 032U161431, HVAC code 4122110).
C Outdoor air	K Condensing water tube. Not included in delivery.
D Feed from the distribution board	IP De-aerator. Not included in delivery.
E Air extraction	S External electrical junction box for the MV
F Duct radiator (reverse connection)	C 24 VDC Relay/contactors for controlling the pump and solenoid valve. Not included in delivery. (e.g. ABB CR-P024DC2).
G Heat pump	Y One-way valve. Not included in delivery.
H Heat collection circuit	Y2 One-way valve. Not included in delivery. The pressure loss must be smaller than the pressure loss of the heat pump.
N External NTC sensor	

5.8. Dimensions and duct outlets

Figure 6. Dimensions

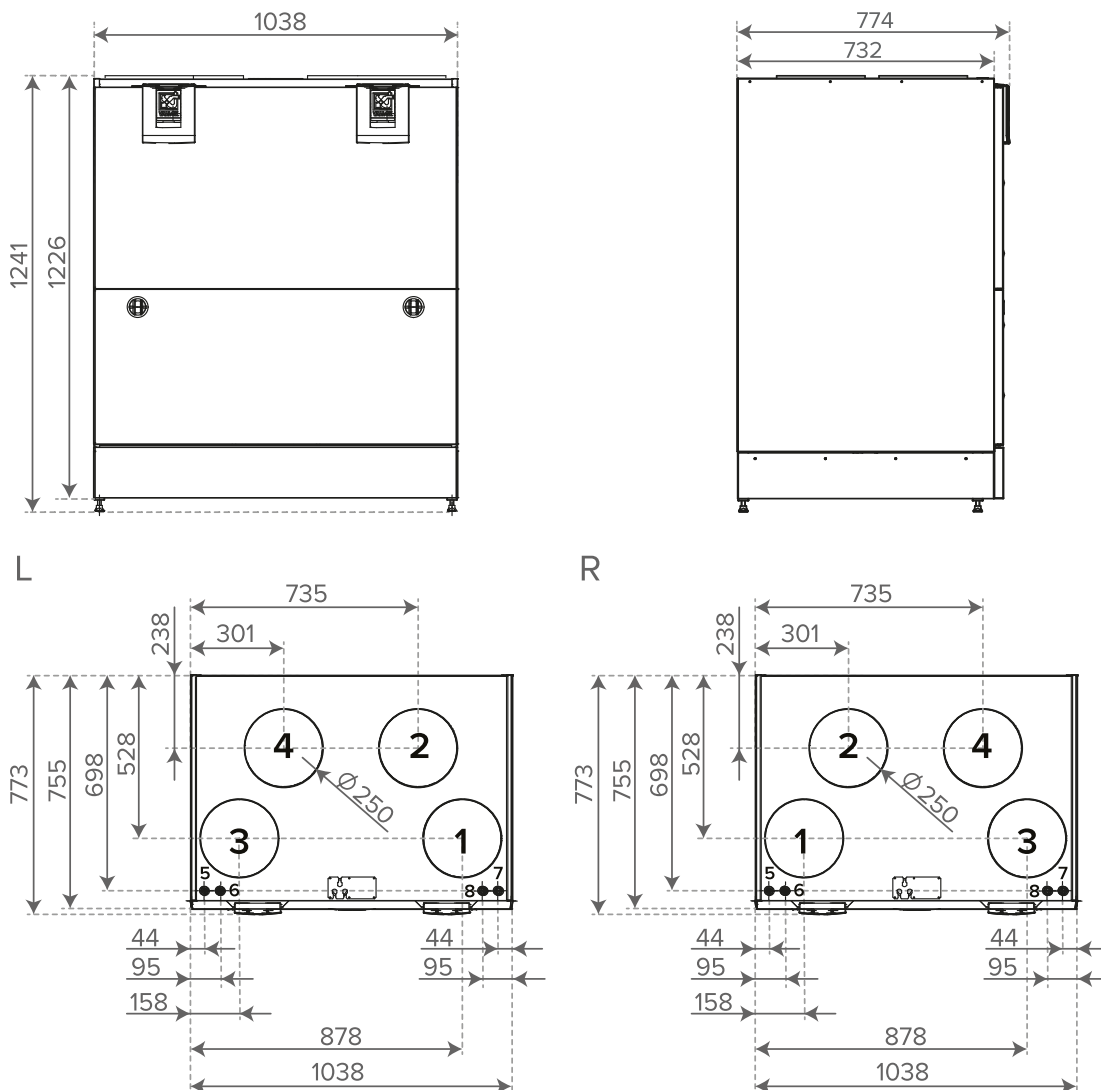

Duct outlets

Inner diameter of the female collar $\varnothing 250$ mm.

1. Supply air from unit to apartment
2. Extract air from apartment to unit
3. Exhaust air from unit to outdoors
4. Outdoor air to unit
5. Liquid radiator output (VKL model) $\varnothing 15$ mm
6. Liquid radiator input (VKL model) $\varnothing 15$ mm
7. Liquid radiator output (VKL model) $\varnothing 15$ mm
8. Liquid radiator input (VKL model) $\varnothing 15$ mm

6. EXPLODED VIEW AND LIST OF SPARE PARTS

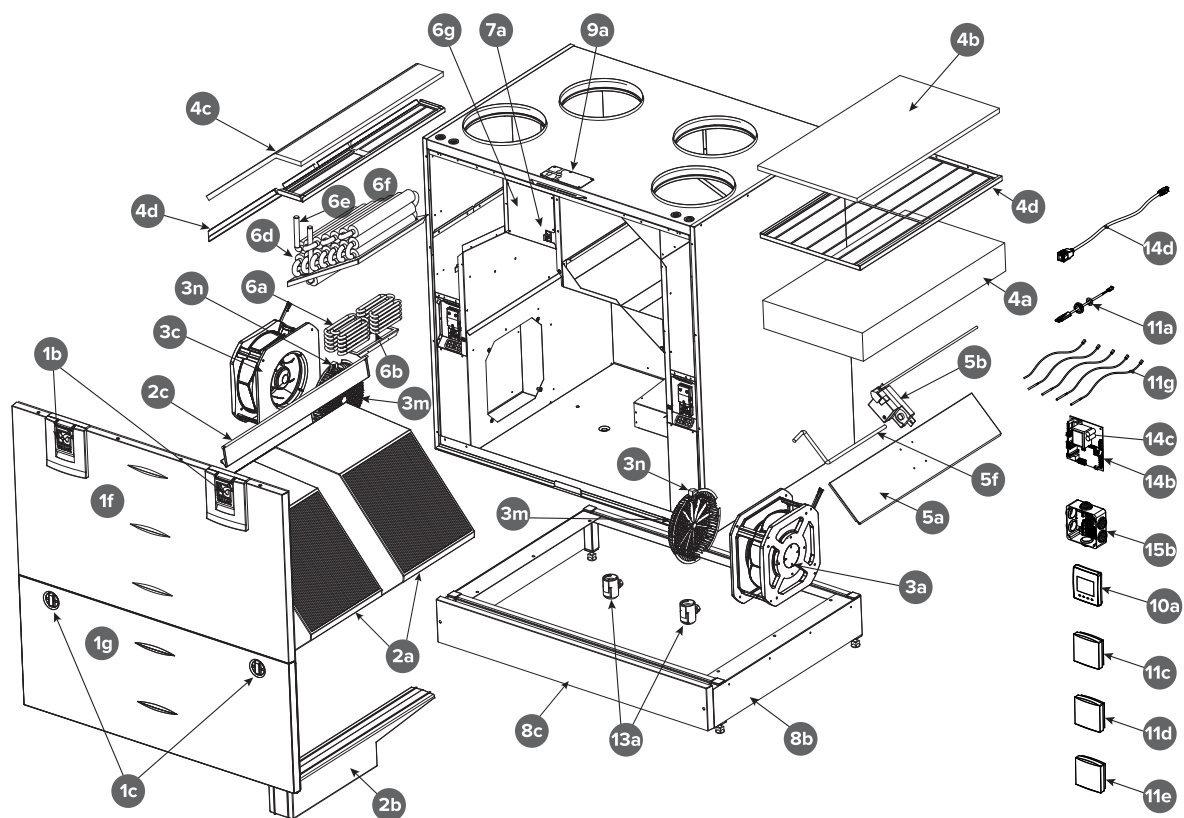

No.	Part	No.	Part
1b	Door latch	6d	Liquid radiator assembly
1c	Door finger screw	6e	Liquid radiator valve
1f	Upper door	6f	Liquid radiator actuator
1g	Lower door	6g	Liquid radiator control relay
2a	HR cell	7a	Safety switch
2b	Lower support of the HR cell	8b	Base assembly
2c	Upper sealing strip of the HR cell	8c	Front panel of the base
3a	Extract air fan	9a	Ceiling bushing Ceiling feedthrough seal
3c	Supply air fan	10a	MyVallox control panel
3m	Anemometer	11a	Internal humidity and carbon dioxide sensor
3n	Hall sensor circuit board	11c	MyVallox carbon dioxide sensor
4a	Fine filter for supply air	11d	MyVallox humidity sensor
4b	Coarse filter for supply air	11e	MyVallox VOC sensor (optional)

No.	Part	No.	Part
4c	Coarse filter for extract air	11g	NTC sensor kit
4d	Filter stand	13a	Siphon Vallox Silent Klick
5a	Bypass damper of the HR cell	14b	Motherboard
5b	Bypass damper actuator	14c	Glass tube fuse 63 mA slow 5 x 20 mm
5f	Bypass arm	14d	RJ45 extension cable
6a	Post-heating resistor	15b	Connection box
6b	Additional heating resistor		

! NOTE: If the fan's anemometer or the Hall sensor's circuit board breaks during the unit's warranty period, the entire fan must be replaced. After the warranty period, only the fan's anemometer and/or the Hall sensor's circuit board can be replaced instead of the entire fan.

7. DECLARATION OF CONFORMITY



DECLARATION OF CONFORMITY

DECLARATION OF CONFORMITY

Manufacturer Vallox Oy
Address Myllykyläntie 9-11, FIN-32200 LOIMAA, FINLAND
Telephone number +358 10 7732 200
The person who compiles the technical file Petri Koivunen
Vallox Oy
Myllykyläntie 9-11, FIN-32200 LOIMAA, FINLAND
Tel. +358 10 7732 200
Email info@vallox.com
Description of unit Ventilation unit with heat recovery

Model MyVallox 51/51K/99/119/125/149/245/ 245 VKL CFI
Vallox 51/51K SC/MV,
Vallox 99/125/096/110/145/245/245 VKL MV,
Vallox 99 MV CF,
Vallox TSK Multi 50/80 MV,
ValloPlus 180/180K/270/370/510/520/850 MV,
ValloPlus 180/270 SC,
ValloMulti 200 SC/MV, ValloMulti 300 MV

Declares that the ventilation unit for supply and extract air, equipped with heat recovery and operating as part of a ventilation system has been designed and manufactured to the following specifications:

1. Low Voltage Directive (2014/35/EU) – EN 60335-1:2012 + A11:2014, A13:2017 + A1:2919 + A14:2019 + A2:2019; EN 62233:2008
2. EMC Directive (2014/30/EU) – EN 61000-6-1:2007, EN 61000-3-2:2014 + A1:2009 + A2:2009, EN 61000-3-3:2013, EN 61000-6-3:2007 + A1:2011
3. Ecodesign Directive (2009/125/EY) – Commission regulation 1253/2014 – EN 13141-7 Annex B, EN 308, EN 13141-7, ISO 3741, ISO 5135
4. RoHS Directive (2011/65/EU, 2015/863/EU)

This is the original Declaration of Conformity

Loimaa, 22nd September 2025

Jukka-Pekka Korja
Managing Director

Vallox Oy
Myllykyläntie 9-11
FI-32200 LOIMAA
FINLAND

Tel. +358 10 7732 200
Fax. +358 10 7732 201
www.vallox.com
firstname.familyname@vallox.com

ALV rek./VAT
Y-tunnus | Business ID:
Kotipaikka|Registered Domicile: Loimaa, Finland

FI06723509
0672350-9

VALLOX

www.vallox.com

Vallox Oy | Myllykyläntie 9-11 | 32200 LOIMAA | FINLAND

D11735/17.06.2026EN/PDF