

-  Sewage
-  Domestic use
-  Civil use
-  Industrial use

※ **Powerful and robust high-efficiency pumps made entirely of stainless steel**



※ **Constructed entirely from stainless steel, BC-ST submersible pumps offer superior corrosion and abrasion.**

PERFORMANCE RANGE

- Flow rate up to **850 l/min** (51 m³/h)
- Head up to **16 m**

INSTALLATION AND USE

BC-ST stainless steel submersible pumps are designed to drain dirty and **sewage water** in **domestic, civil, and industrial settings**. Featuring a **TWO-CHANNEL** impeller, they can efficiently pump liquids containing suspended solids up to 50 mm in diameter with short fibers and handle wastewater, sewage, surface water, and sludge-mixed water in residential properties.

※ The hydraulic configuration of the volute and **TWO-CHANNEL** impeller results from advanced fluid dynamics calculations, delivering superior performance and efficiency for notable energy savings.

※ The **TWO-CHANNEL** impeller provides excellent performance and high energy efficiency, generating increased pressure for pumping solids up to **50 mm** in diameter, making it the best choice for wastewater drainage.

INCLUDES

- ※ Power cable length **10 m**
- ※ Float switch (exclusive to single-phase models)

APPLICATION LIMITS

- Depth below water level up to **5 m** (with an appropriately sized power cable)
- Liquid temperature up to **+40 °C**
- Capable of processing suspended solids up to **Ø 50 mm**
- **Minimum immersion for continuous service:**
 - **290 mm for BC 10/50-ST**
 - **330 mm for BC 15/50-ST**
 - **360 mm for BC 20/50-ST**

AVAILABLE UPON REQUEST

- ※ AISI 316L stainless steel pump shaft
- ※ Different voltage or frequency

PATENTS - TRADE MARKS - MODELS

- Patent No. EP2313658
- Patent No. IT0001428923

CURVES AND PERFORMANCE DATA

60 Hz

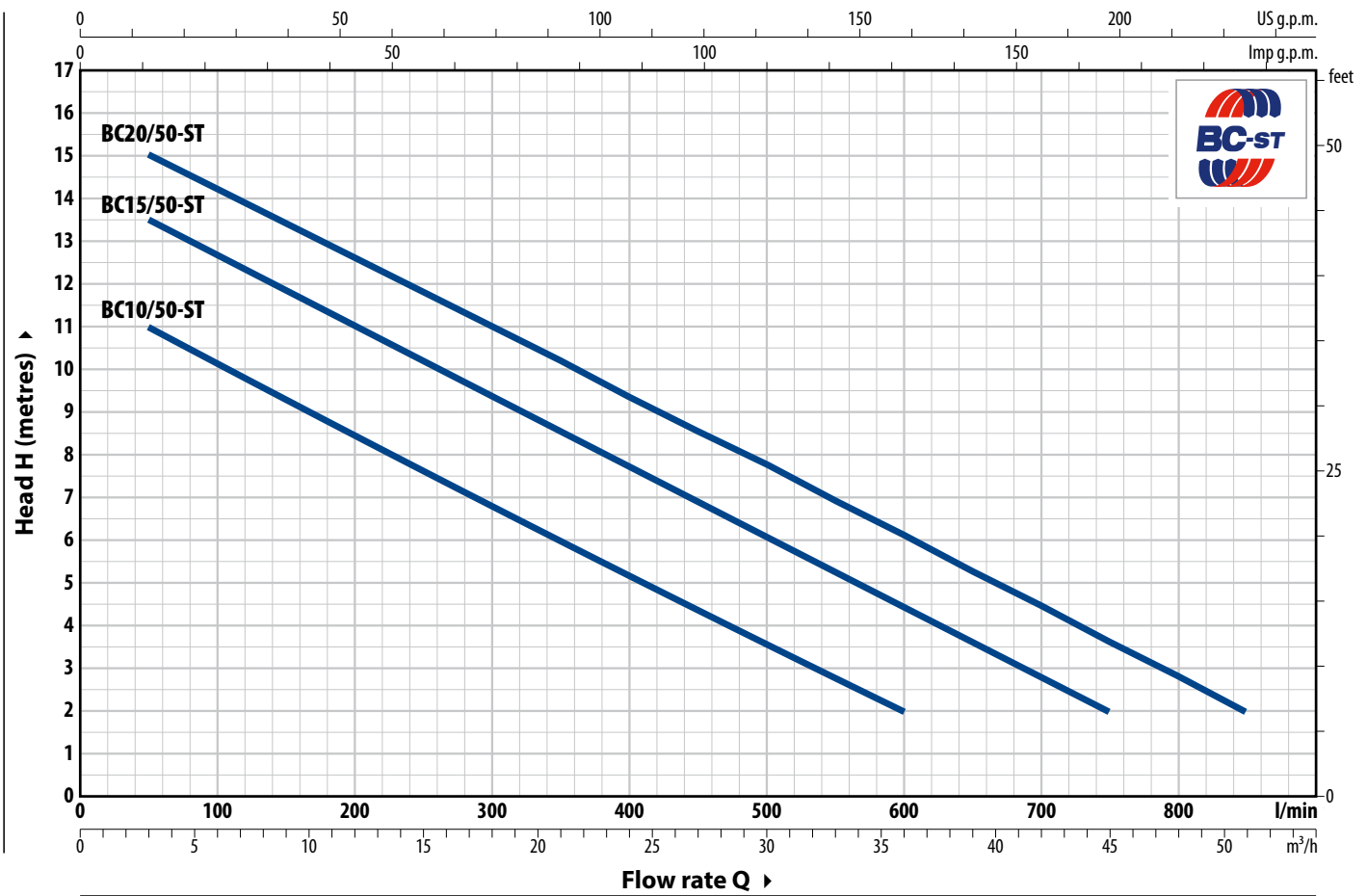

TYPE		POWER (P ₂)		Q	Flow rate														
Single-phase	Three-phase	kW	HP		m ³ /h	0	3	6	12	18	24	30	36	42	45	51			
					0	50	100	200	300	400	500	600	700	750	850				
BCm 10/50-ST	BC 10/50-ST	0.75	1	H metres	12	11	10.3	8.6	6.9	5	3.6	2							
BCm 15/50-ST	BC 15/50-ST	1.1	1.5		14.5	13.5	12.8	11.2	9.5	7.8	6.1	4.5	2.8	2					
BCm 20/50-ST	BC 20/50-ST	1.5	2		16	15	14.4	12.8	11.1	9.5	7.9	6.2	4.5	3.7	2				

Q = Flow rate H = Total manometric head

Performance curves comply with EN ISO 9906 Grade 3B tolerance limits.

ABSORPTION

TYPE	VOLTAGE	
	220 V	110 V
BCm 10/50-ST	6.3 A	12.6 A
BCm 15/50-ST	8.0 A	-
BCm 20/50-ST	10.0 A	-

TYPE	VOLTAGE	
	380 V	440 V
BC 10/50-ST	2.4 A	2.2 A
BC 15/50-ST	3.5 A	3.3 A
BC 20/50-ST	4.3 A	3.8 A

DIMENSIONS AND WEIGHT

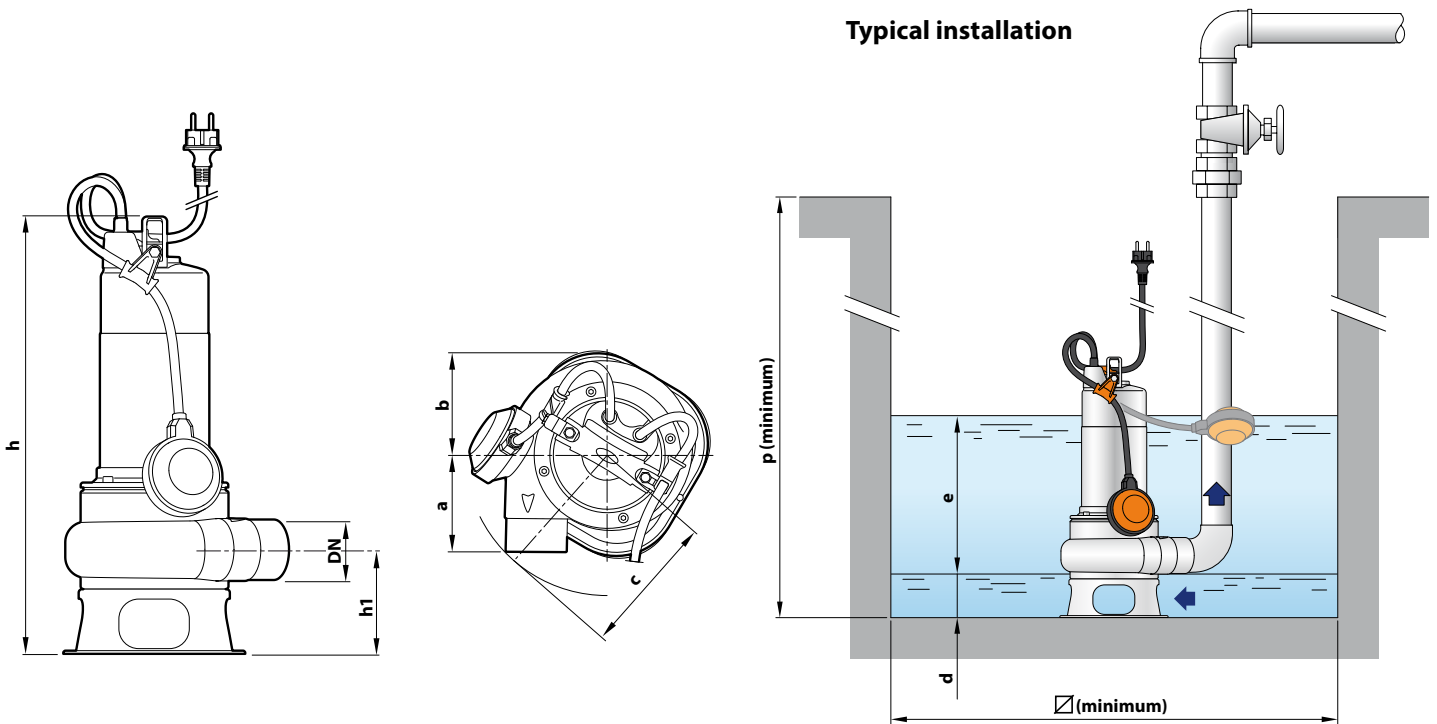

TYPE		PORT DN	Passage of solid bodies	DIMENSIONS mm									kg	
Single-phase	Three-phase			a	b	c	h	h1	d	e	p	∅	1~	3~
BCm 10/50-ST	BC 10/50-ST	2"	∅ 50 mm	102	95	145	450	107	60	adjustable	500	500	13.4	12.2
BCm 15/50-ST	BC 15/50-ST						483						16.0	14.4
BCm 20/50-ST	BC 20/50-ST						513						18.2	16.0

PALLET CAPACITY

TYPE		GROUPAGE n. pumps	CONTAINER n. pumps
Single-phase	Three-phase		
BCm 10/50-ST	BC 10/50-ST	45	60
BCm 15/50-ST	BC 15/50-ST	30	45
BCm 20/50-ST	BC 20/50-ST	30	45

MATERIALS AND COMPONENTS

1 Pump body	AISI 304 stainless steel with ISO 228/1 threaded port		
2 Base	Stainless steel AISI 304		
3 Impeller	TWO-CHANNEL type in micro-cast AISI 304 stainless steel.		
4 Motor sleeve	Stainless steel AISI 304		
5 Motor cover	AISI 304 stainless steel for BC 10/50-ST Cast iron with cataphoresis treatment for BC 15/50-ST, BC 20/50-ST		
6 Motor shaft	Stainless steel AISI 431		
7 Double mechanical seal in oil chamber			
Seal	Shaft	Location	Materials
MG1-14D SIC	Ø 14 mm	Motor side Pump side	Silicon carbide / Graphite / NBR Silicon carbide/Silicon carbide/NBR
8 Capacitor (exclusive to single-phase models)			
9 Electric motor			
BCm-ST:	single-phase 220 V - 60 Hz or 110 V - 60 Hz with winding integrated thermal motor protection		
BC-ST:	three-phase 380 V - 60 Hz or 440 V - 60 Hz		
	– Insulation: class F		
	– Protection rating: IP X8		
10 Power cord			
	Power cable encapsulated with epoxy resin both in the grommet area and where the conductors exit the sheath, for absolute insulation against moisture and water.		
	Type 'H07 RN-F' (Schuko plug exclusive to single-phase models)		
	※ Standard length 10 metres		
11 Float switch (exclusive to single-phase models)			
12 Tilting device for the float cable (exclusive to single-phase models)	Patent No. IT0001428923		
13 Power cable strain relief Patent No. EP2313658			

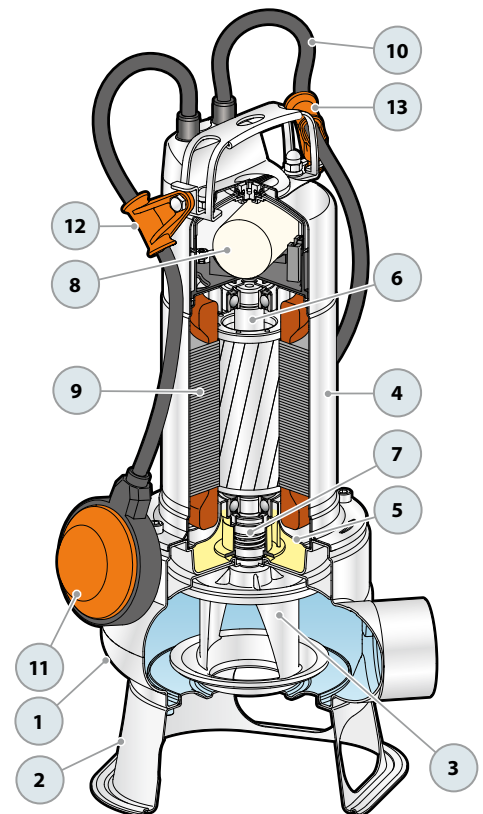

SEWAGE LIFTING SYSTEM KIT VX-ST - BC-ST

VERSION WITH HORIZONTAL DELIVERY AND 3/4" GUIDE PIPES

For VX /35-ST	CODE ASSPVX35ST	DN 2"
For VX /50-ST , BC /50-ST	CODE ASSPVX50ST	DN 2"

※ Kit consisting of:



Coupling foot



Solids rail with ring nut and seal



Support for guide tubes



VERSION WITH VERTICAL DELIVERY AND 3/4" GUIDE PIPES

For VX /35-ST	CODE ASSPVX35STV	DN 2½"
For VX /50-ST, BC /50-ST	CODE ASSPVX50STV	DN 2½"

※ Kit consisting of:



Coupling foot complete with counterflange



Solids rail with ring nut and seal



Support for guide tubes



● ACCESSORIES AVAILABLE FOR ORDER

RUNNING GUIDE

※ For VX /35-ST	CODE ASSFL005
※ For VX /50-ST , BC /50-ST	CODE ASSFL006

Complete with ring nut and gasket

GUIDE TUBE SUPPORT

※ For Ø 3/4 " guide tubes	CODE 859SV340INTFA
---------------------------	--------------------

To ensure stability, insert a support every 2 metres along the guide tube

GUIDE TUBE (AISI 304 stainless steel)

※ 2 metres Ø 3/4" guide tube	CODE 54SARTG0052F
※ 3 metres Ø 3/4" guide tube	CODE 54SARTG0053F
※ 6 metres Ø 3/4" guide tube	CODE 54SARTG0056F



DIMENSIONS (Version with horizontal outlet)

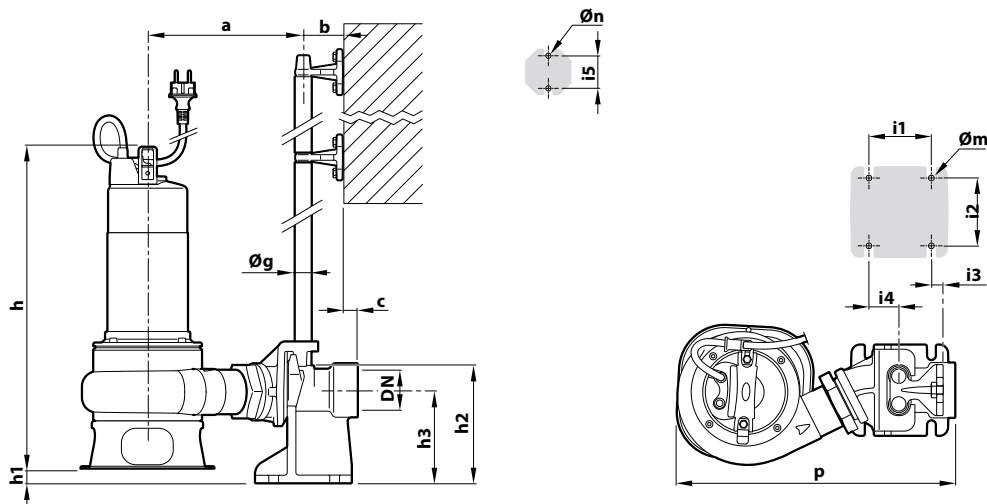

TYPE		Passage of solid bodies mm	PORT DN	DIMENSIONS mm															
Single-ph.	Three-ph.			a	b	c	p	h	h1	h2	h3	i1	i2	i3	i4	i5	Øg	Øm	Øn
VXm 8/35 -ST	VX 8/35 -ST	40	2"	214			386	424	24										
VXm 10/35 -ST	VX 10/35 -ST							439											
VXm 15/35 -ST	VX 15/35 -ST							472											
VXm 20/35 -ST	VX 20/35 -ST							502											
VXm 8/50 -ST	VX 8/50 -ST	50	2"	221	61	17	372	435	23	165	130	85	94	16	40	50	¾"	12	11
VXm 10/50 -ST	VX 10/50 -ST							450											
VXm 15/50 -ST	VX 15/50 -ST							483											
VXm 20/50 -ST	VX 20/50 -ST							513											
BCm 10/50 -ST	BC 10/50 -ST	50	2"					450											
BCm 15/50 -ST	BC 15/50 -ST							483											
BCm 20/50 -ST	BC 20/50 -ST							513											

DIMENSIONS (Version with vertical delivery)

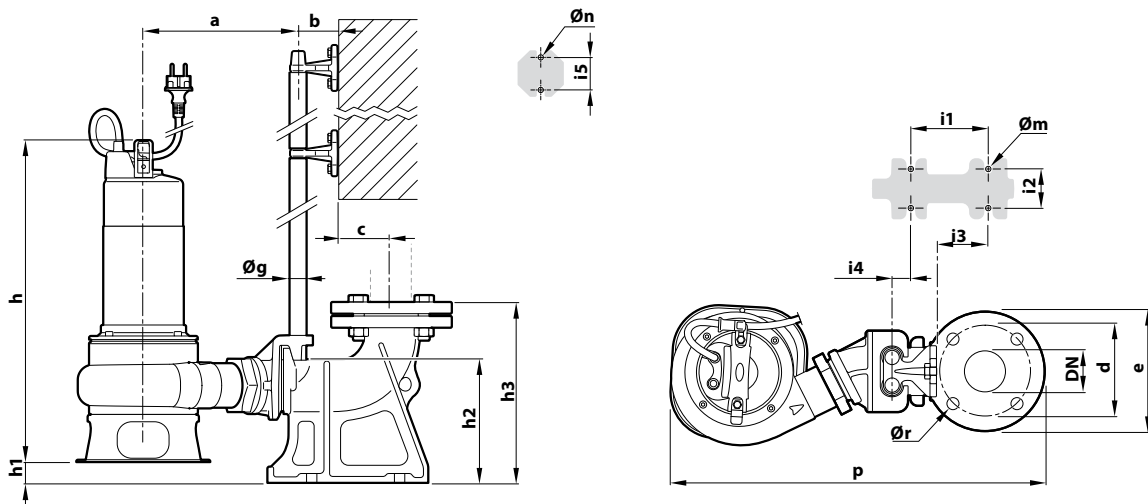

TYPE		Passage of solid bodies mm	PORT DN	DIMENSIONS mm																	
Single-ph.	Three-ph.			a	b	c	d	e	p	h	h1	h2	h3	i1	i2	i3	i4	i5	Øg	Øm	Øn
VXm 8/35 -ST	VX 8/35 -ST	40	2½"	207				495	424	22											
VXm 10/35 -ST	VX 10/35 -ST								439												
VXm 15/35 -ST	VX 15/35 -ST								472												
VXm 20/35 -ST	VX 20/35 -ST								502												
VXm 8/50 -ST	VX 8/50 -ST	50	2½"	212	61	52	125	165	435	26	164	215	120	72	62	3	50	¾"	14	11	18
VXm 10/50 -ST	VX 10/50 -ST								450												
VXm 15/50 -ST	VX 15/50 -ST								483												
VXm 20/50 -ST	VX 20/50 -ST								513												
BCm 10/50 -ST	BC 10/50 -ST	50	2½"						450												
BCm 15/50 -ST	BC 15/50 -ST								483												
BCm 20/50 -ST	BC 20/50 -ST								513												