

CAT. NO.	WIRE RANGE	STUD SIZE [METRIC SIZE]	HYDRAULIC TOOLING			DIELESS TOOLING	NO. CRIMPS	WIRE STRIP LENGTH	
			DIE INDEX	TOOL CAT. NO.	DIE TYPE				DIE CAT. NO.
YAD27M10E38	3/0 AWG STR. CU CODE & FLEX [70-95]mm ²	3/8" [10]	1023	Y35, Y39, Y750, PAT750	NEST	U29D1	Y81KFT- SERIES PAT81KFT- SERIES Y4PC834- SERIES PAT4PC834- SERIES	1	7/8"
					INDENTOR	Y34PR2			

REV	DATE	DESCRIPTION	ECO	BY	C'H'K.
A	10/31/2012	SALES DRAWING RELEASE	29246	DK	MA

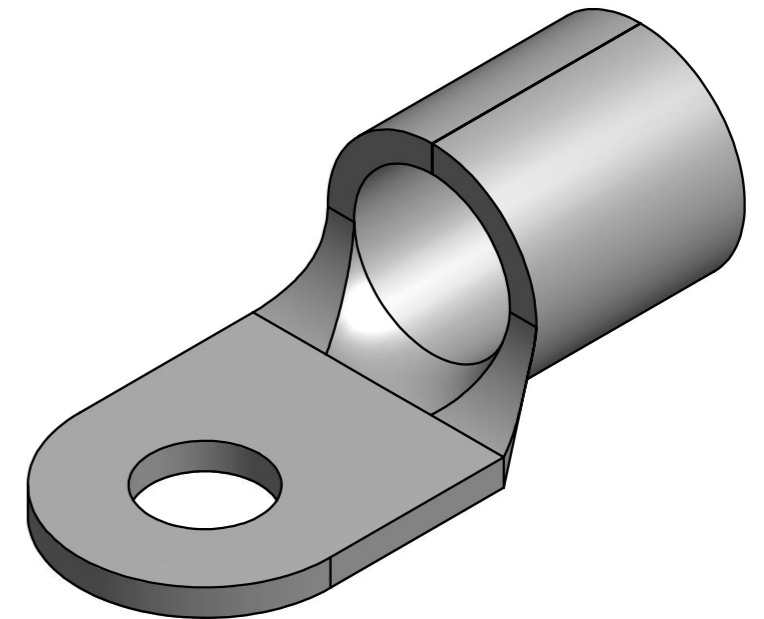
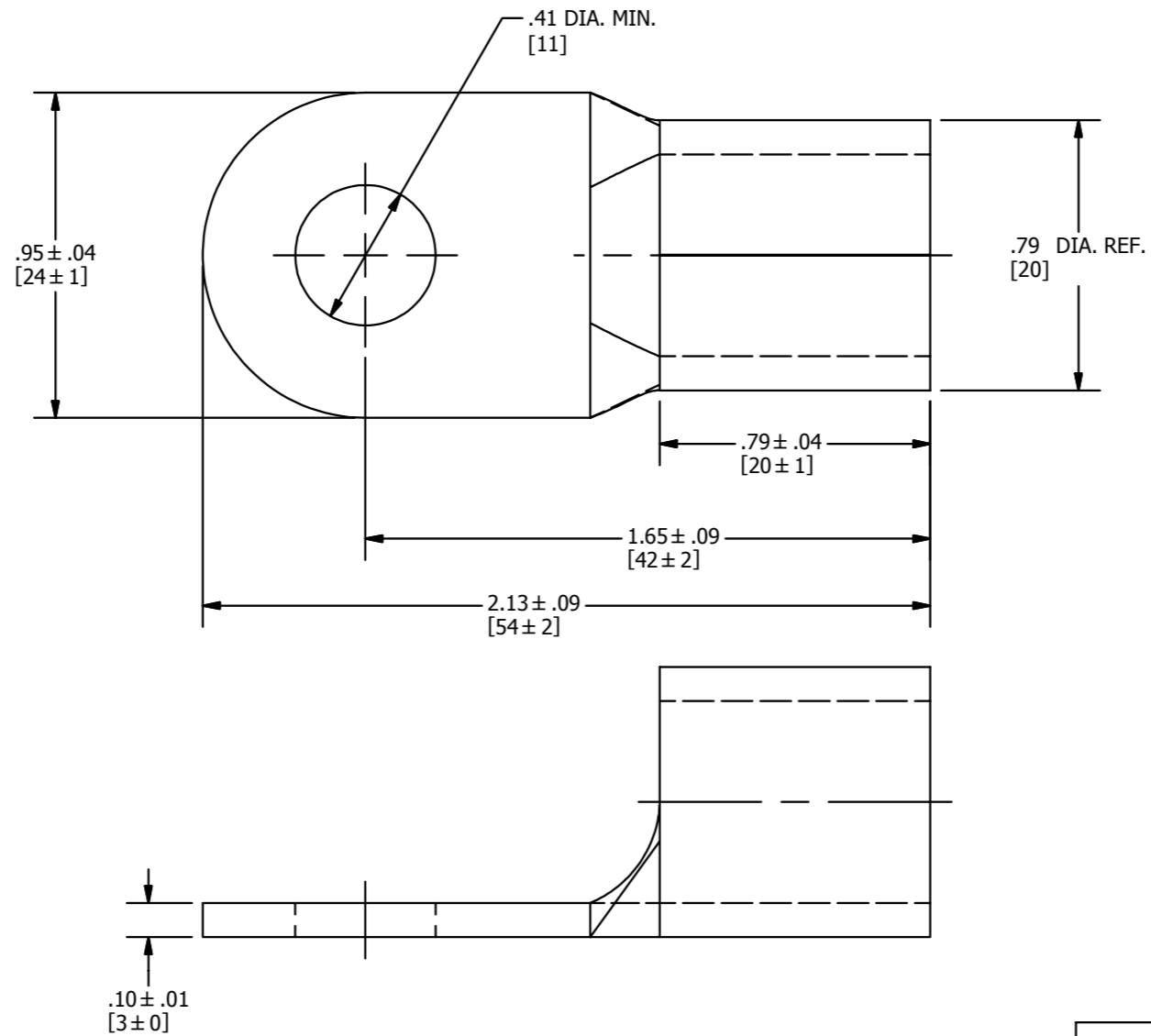

NOTES:

- MATERIAL: COPPER.
- FINISH: TIN PLATED.
- Y35P3 ADAPTOR REQUIRED FOR Y34PR2 INDENTORS IN Y35, Y39, Y750 AND PAT750 TOOLS.
- DIMENSIONS IN BRACKETS [] ARE IN MILLIMETERS ROUNDED OFF TO THE NEAREST MILLIMETER, UNLESS OTHERWISE NOTED, AND ARE FOR REFERENCE ONLY.

TO ORDER BURNDY PRODUCTS CALL		NON-INSULATED BRAZED BARREL COPPER TERMINAL	
UNITED STATES		ITEM NO: 50002480	
1-800-346-4175 (LONDONDERRY, NH)		CAT. NO: YAD27M10E38	
CANADA:		DRAWN BY: N.D.KANNAN 10/31/2012	
1-800-361-6975 (QUEBEC)		CHECKER: J.MICHAUD 11/29/2012	
1-800-387-6487 (ALL OTHER PROVINCES)		DSN APRVL: J.MICHAUD 11/29/2012	
FOR PRODUCT INFO: http://www.burndy.com		MFG APRVL: C.KOWALCZYK 11/29/2012	
		MKT APRVL: S.GALE 11/29/2012	
		PROJ #:	
		SIZE	
		DRAWING NO	
		REV	
		50013614	
		A	
		SHEET 1 OF 1	