

Industrial Water Chiller TAL



CONNECT AND PROTECT

INDUSTRIAL WATER CHILLER – TAL



Figure 1. Size 1 - TAL24-A0



Figure 2. Size 2 - TALA1-A8



Figure 3. Size 3 - TALB5-C5



Figure 4. Size 4 - TALD0-E6

Industry Standards

- UL
- CE

Application

- Machine Tooling
- Laser Cutting
- Plastics Manufacturing
- Battery Energy Storage
- Paired with Air to Water Heat Exchangers for Enclosures
- And much more

Features

- Compact footprint to minimize real estate and maximize capacity
- Fluid type: water, water/glycol mixture
- R134A earth-friendly refrigerant for Size 1
- R410A refrigerant for Size 2 – Size 4
- Ambient temperature operating limits: 46°F (8°C) to 77°F (25°C)
- Fluid temperature precision of ± 2 K
- Hermetic reciprocating compressor or hermetic scroll compressor cooled by the refrigerant
- Refrigeration circuit complete with charging port, drier filter, expansion valve, high- and low-pressure safety pressure switch
- Evaporator is made of brazed stainless-steel plate model
- Microchannel condensing coil, complete with safety grille
- Axial fan complete with electrical protection and safety grille

Finish

- RAL 7035 light-gray, textured finish powder-coat paint
- Other colors and textures available

Options

- Mechanical bypass valve protecting the pump
- Electrical level indicator
- Operation at low ambient temperatures
- Polyurethane air filter

- Castors
- Differential fluid temperature management (two sensors)
- Hot gas bypass for ± 1 K temperature precision
- High pressure pump

PERFORMANCE DATA TAL24/37

Metric

Model		TAL24		TAL37	
		50Hz	60Hz	50Hz	60Hz
Rated Cooling Capacity*	W	2300	2700	3600	4200
Ambient temperature operating limits	°C	+15 -+45			
Settable fluid temperature range	°C	+8 -+25			
Fluid type		Water			
Temperature precision	K	+/-2			
Refrigerant gas	HFC	R134a			
Power supply					
Supply voltage	V ph Hz	230 V (+/-10%) 1 ph 50/60 Hz			
Controller supply voltage	V	230 V AC			
Digital thermostat		TX110			
Compressor					
Compressor type		Reciprocating			
Quantity - Number of circuits	no.	1 - 1			
Nominal power draw	kW	0.84	1.04	1.16	1.5
Axial Fan					
Fan type		Axial			
Quantity	no.	1		1	
Air flow rate	m³/h	1250 - 1650		1550 - 2050	
Centrifugal Fan (optional)					
Fan type		Centrifugal			
Quantity	no.	1			
Air flow rate	m³/h	2100 - 2400		2100 - 2400	
Available head	Pa	250			
Standard Pump					
Pump type		Peripheral			
Quantity	no.	1			
Nominal/max fluid flow rate	l/min	7 - 18		10 - 18	
Nominal available head	bar	3.8	5.8	3.1	4.5
High-Pressure Pump (optional)					
Pump type		Peripheral			
Quantity	no.	1			
Nominal available head	bar	5.6	7.5	5	6.8
Storage tank capacity	l	50			
IN/OUT liquid connections	mm	3/4"			
Net weight (approximate)***	kg	151		153	
Width - Depth - Height	mm	600 - 740 - 1317			
Sound pressure level**	dB(A)	57	60	57	60

* Data relates to operation under the following conditions: inlet/outlet temp. 20/15°C, water without glycol, ambient temperature 32°C.

** Sound pressure level, measured in a free parallelepiped field at a distance of 1 m, per ISO 3746.

*** Weight includes pallets and packaging (where provided for), with refrigerant charge, storage tank empty, axial fans.

The electrical data refer to $\cos \varphi = 0.8$.

Correction factors for calculating the cooling power												
Water outlet temperature	Fw	°C				8	10	15	20	25		
		factor				0.69	0.77	1	1.22	1.44		
Ambient temperature	Fa	°C				15	20	25	32	35	40	45
		factor				1.26	1.2	1.11	1	0.95	0.87	0.8
Percentage glycol by weight	Fg	%	0	10	15	20	25	30	35	40		
		factor	1	0.96	0.95	0.94	0.93	0.91	0.9	0.88		

Cooling power = Nominal cooling power x Fw x Fa x Fg
 *4200 W is the maximum achievable cooling capacity for Size 1 single phase chillers.

PERFORMANCE DATA TAL24/37

Imperial

Model		TAL24		TAL37	
		50Hz	60Hz	50Hz	60Hz
Rated Cooling Capacity*	BTU/hr	7850	9210	12280	14330
Ambient temperature operating limits	°F	+59 -+113			
Settable fluid temperature range	°F	+46 -+77			
Fluid type		Water			
Temperature precision	°F	+/-3.6			
Refrigerant gas	HFC	R134a			
Power supply					
Supply voltage	V ph Hz	230 V (+/-10%) 1 ph 50/60 Hz			
Controller supply voltage	V	230 V AC			
Digital thermostat		TX110			
Compressor					
Compressor type		Reciprocating			
Quantity - Number of circuits	no.	1 - 1			
Nominal power draw	kW	0.84	1.04	1.16	1.5
Axial Fan					
Fan type		Axial			
Quantity	no.	1		1	
Air flow rate	cfm	735 - 970		910 - 1200	
Centrifugal Fan (optional)					
Fan type		Centrifugal			
Quantity	no.	1			
Air flow rate	cfm	1230 - 1410		1230 - 1410	
Available head	psi	0.036			
Standard Pump					
Pump type		Peripheral			
Quantity	no.	1			
Nominal/max fluid flow rate	gpm	1.8 - 4.8		2.6 - 4.8	
Nominal available head	psi	55	84	45	65
High-Pressure Pump (optional)					
Pump type		Peripheral			
Quantity	no.	1			
Nominal available head	psi	81	109	73	99
Storage tank capacity	gal	13.2			
IN/OUT liquid connections	in	3/4"			
Net weight (approximate)***	lbs	332		337	
Width - Depth - Height	in	23.6 - 29.1 - 51.9			
Sound pressure level**	dB(A)	57	60	57	60

* Data relates to operation under the following conditions: inlet/outlet temp. 68/59°F, water without glycol, ambient temperature 90°F.

** Sound pressure level, measured in a free parallelepiped field at a distance of 1 m, per ISO 3746.

*** Weight includes pallets and packaging (where provided for), with refrigerant charge, storage tank empty, axial fans.

The electrical data refer to cos φ = 0.8.

Correction factors for calculating the cooling power										
Water outlet temperature	Fw	°F	46	50	59	68	77			
		factor	0.69	0.77	1	1.22	1.44			
Ambient temperature	Fa	°F	59	68	77	90	95	104	113	
		factor	1.26	1.2	1.11	1	0.95	0.87	0.8	
Percentage glycol by weight	Fg	%	0	10	15	20	25	30	35	40
		factor	1	0.96	0.95	0.94	0.93	0.91	0.9	0.88

Cooling power = Nominal cooling power x Fw x Fa x Fg
 *14,300 BTU/hr is the maximum achievable cooling capacity for Size 1 single phase chillers.

PERFORMANCE DATA TAL29/37/46/57/76/93/A0 THREE-PHASE

Metric

Model		TAL29	TAL37	TAL46	TAL57	TAL76	TAL93	TALAO	
Rated Cooling Capacity*	W	2900	3600	4550	6000	8100	9550	10900	
Ambient temperature operating limits	°C	+15 -+45							
Settable fluid temperature range	°C	+8 -+25							
Fluid type		Water							
Temperature precision	K	+/-2							
Refrigerant gas	HFC	R134a							
Power supply									
Supply voltage	V ph Hz	460 V (+/-10%) 3 ph 50/60 Hz							
Controller supply voltage	V	230 V AC							
Digital thermostat		TX110							
Compressor									
Compressor type		Reciprocating				Scroll			
Quantity - Number of circuits	no.					1 - 1			
Nominal power draw	kW	0.78	1.16	1.42	2.42	2.21	2.60	2.73	
Axial Fan									
Fan type		Axial							
Quantity	no.	1							
Air flow rate	m³/h	1550	1550	1800	1800	3150	3350	4400	
Centrifugal Fan (optional)									
Fan type		Centrifugal							
Quantity	no.	1							
Air flow rate	m³/h	2100 - 2400							
Available head	Pa	250							
Standard Pump									
Pump type		Centrifugal							
Quantity	no.	1							
Nominal/max fluid flow rate	l/min	8 - 40	10 - 40	12.5 - 40	16 - 40	21 - 70	26 - 70	31.5 - 70	
Nominal available head	bar	3	2.9	2.8	2.7	3.1	3	2.8	
High-Pressure Pump (optional)									
Pump type		Centrifugal							
Quantity	no.	1							
Nominal available head	bar	5.1	4.9	4.8	4.6	5.5	5.3	5.1	
Storage tank capacity	l	50							
IN/OUT liquid connections	mm	3/4"							
Net weight (approximate)***	kg	151	153	155	160	165	170	175	
Width - Depth - Height	mm	600 - 740 - 1317							
Sound pressure level**	dB(A)	57							

* Data relates to operation under the following conditions: inlet/outlet temp. 20/15°C, water without glycol, ambient temperature 32°C.

** Sound pressure level, measured in a free parallelepiped field at a distance of 1 m, per ISO 3746.

*** Weight includes pallets and packaging (where provided for), with refrigerant charge, storage tank empty, axial fans.

The electrical data refer to $\cos \varphi = 0.8$.

Correction factors for calculating the cooling power										
Water outlet temperature	Fw	°C				8	10	15	20	25
		factor				0.69	0.77	1	1.22	1.44
Ambient temperature	Fa	°C				15	20	25	32	35 40 45
		factor				1.26	1.2	1.11	1	0.95 0.87 0.8
Percentage glycol by weight	Fg	%	0	10	15	20	25	30	35	40
		factor	1	0.96	0.95	0.94	0.93	0.91	0.9	0.88

Cooling power = Nominal cooling power x Fw x Fa x Fg
 *10,900 W is the maximum achievable cooling capacity for Size 1 three phase chillers.

PERFORMANCE DATA TAL29/37/46/57/76/93/A0 THREE-PHASE

Imperial

Model		TAL29	TAL37	TAL46	TAL57	TAL76	TAL93	TAL A0	
Rated Cooling Capacity*	BTU/hr	9900	12300	15500	20500	27600	32600	37200	
Ambient temperature operating limits	°F	+59 -+113							
Settable fluid temperature range	°F	+46 -+77							
Fluid type		Water							
Temperature precision	°F	+/-3.6							
Refrigerant gas	HFC	R134a							
Power supply									
Supply voltage	V ph Hz	460 V (+/-10%) 3 ph 50/60 Hz							
Controller supply voltage	V	230 V AC							
Digital thermostat		TX110							
Compressor									
Compressor type		Reciprocating				Scroll			
Quantity - Number of circuits	no.					1 - 1			
Nominal power draw	kW	0.78	1.16	1.42	2.42	2.21	2.60	2.73	
Axial Fan									
Fan type		Axial							
Quantity	no.	1							
Air flow rate	cfm	910	910	1060	1060	1850	1970	2590	
Centrifugal Fan (optional)									
Fan type		Centrifugal							
Quantity	no.	1							
Air flow rate	cfm	1230 - 1410							
Available head	in. H ₂ O	1							
Standard Pump									
Pump type		Centrifugal							
Quantity	no.	1							
Nominal/max fluid flow rate	gpm	2.1 - 10.5	2.6 - 10.5	3.3 - 10.5	4.2 - 10.5	5.5 - 18.5	6.8 - 18.5	8.3 - 18.5	
Nominal available head	psi	43	42	40	39	45	43	40	
High-Pressure Pump (optional)									
Pump type		Centrifugal							
Quantity	no.	1							
Nominal available head	psi	74	71	70	67	80	77	74	
Storage tank capacity	gal	13.2							
IN/OUT liquid connections	in	3/4"							
Net weight (approximate)***	lbs	333	337	342	353	364	375	386	
Width - Depth - Height	in	23.6 - 29.1 - 51.9							
Sound pressure level**	dB(A)	57							

* Data relates to operation under the following conditions: inlet/outlet temp. 68/59°F, water without glycol, ambient temperature 90°F.

** Sound pressure level, measured in a free parallelepiped field at a distance of 1 m, per ISO 3746.

*** Weight includes pallets and packaging (where provided for), with refrigerant charge, storage tank empty, axial fans.



The electrical data refer to cos φ = 0.8.

Correction factors for calculating the cooling power										
Water outlet temperature	Fw	°F				46	50	59	68	77
		factor				0.69	0.77	1	1.22	1.44
Ambient temperature	Fa	°F				59	68	77	90	95 104 113
		factor				1.26	1.2	1.11	1	0.95 0.87 0.8
Percentage glycol by weight	Fg	%	0	10	15	20	25	30	35	40
		factor	1	0.96	0.95	0.94	0.93	0.91	0.9	0.88

Cooling power = Nominal cooling power x Fw x Fa x Fg
 *37,200 BTU/hr is the maximum achievable cooling capacity for Size 1 three phase chillers.

DRAWINGS SIZE 1: TAL24/37 SINGLE PHASE AND TAL29/37/46/57/76/93/A0 THREE-PHASE

Notes

1. Units: mm
2. CS – Drain connection
3. FA – Air filter (optional)
4. FT – Filling up tank
5. GS – Lifting eye bolts
6. IN/OUT – Inlet and Outlet of water
7. MN – Gauge
8. PQE – Door electrical cabinet
9. TR – Thermostat
10. VL – Visual tank level
11.  – Installation area
12.  – Air flow through condenser

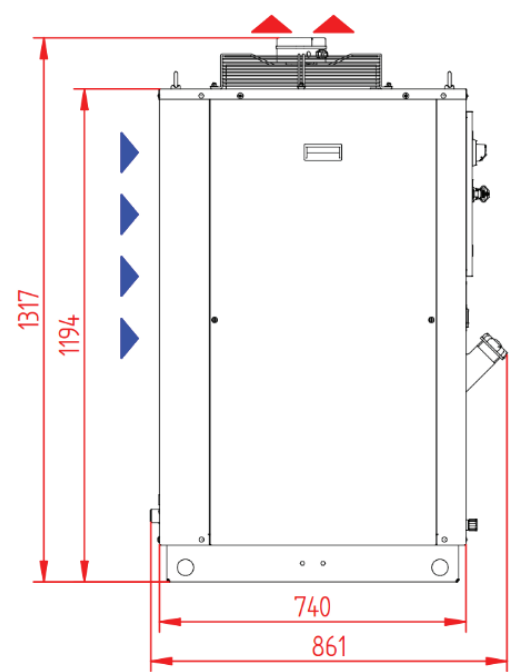
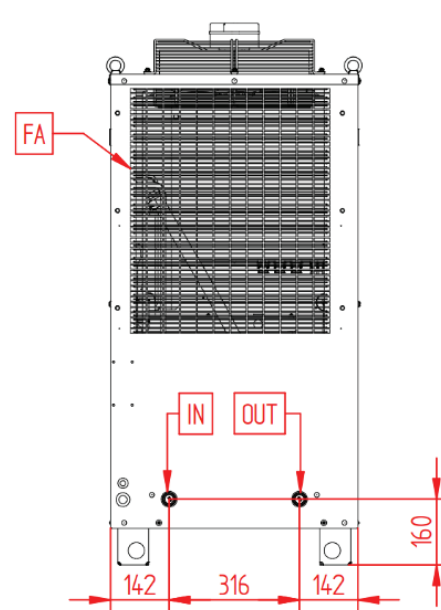
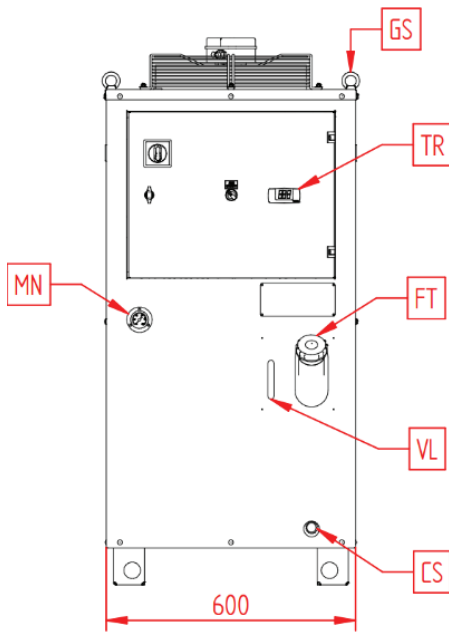
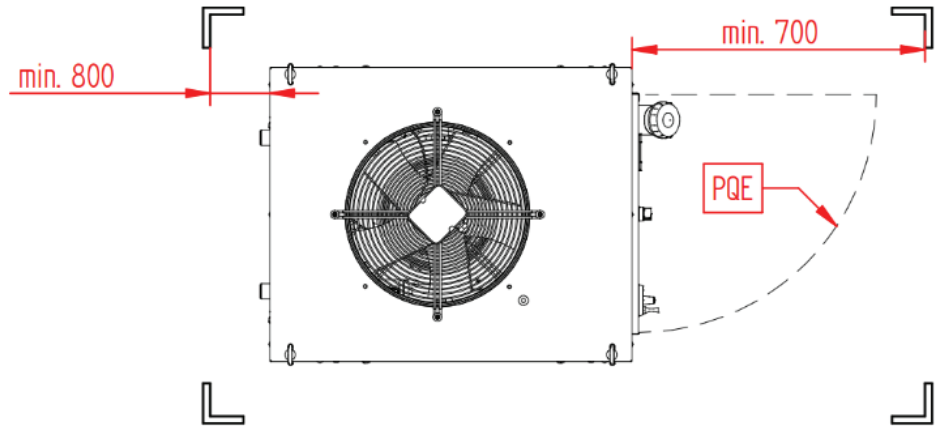

PERFORMANCE DATA TALA1/A3/A5/A8

Metric

Model		TALA1	TALA3	TALA5	TALA8
Rated Cooling Capacity*	W	11400	12400	17800	20100
Ambient temperature operating limits	°C	+15 -+45			
Settable fluid temperature range	°C	+8 -+25			
Fluid type		Water			
Temperature precision	K	+/-2			
Refrigerant gas	HFC	R410a			
Power supply					
Supply voltage	V ph Hz	460 V (+/-10%) 3 ph 50/60 Hz			
Controller supply voltage	V	24 V AC			
Digital thermostat		TX200			
Compressor					
Compressor type		Scroll			
Quantity - Number of circuits	no.	1 - 1			
Nominal power draw	kW	3.03	3.12	4.08	4.91
Axial Fan					
Fan type		Axial			
Quantity	no.	1			
Air flow rate	m³/h	6500			
Centrifugal Fan (optional)					
Fan type		Centrifugal			
Quantity	no.	1			
Air flow rate	m³/h	6500			
Available head	Pa	250			
Standard Pump					
Pump type		Centrifugal			
Quantity	no.	1			
Nominal/max fluid flow rate	l/min	31 - 70	35 - 40	50 - 70	58 - 70
Nominal available head	bar	3.7	3.5	2.8	2.5
High-Pressure Pump (optional)					
Pump type		Centrifugal			
Quantity	no.	1			
Nominal available head	bar	5.2	5	5	4.2
Storage tank capacity	l	130			
IN/OUT liquid connections	mm	1"			
Net weight (approximate)***	kg	200	200	235	235
Width - Depth - Height	mm	750 - 950 - 1526			
Sound pressure level**	dB(A)	67			

* Data relates to operation under the following conditions: inlet/outlet temp. 20/15°C, water without glycol, ambient temperature 32°C.

** Sound pressure level, measured in a free parallelepiped field at a distance of 1 m, per ISO 3746.

*** Weight includes pallets and packaging (where provided for), with refrigerant charge, storage tank empty, axial fans.

The electrical data refer to $\cos \varphi = 0.8$.

Correction factors for calculating the cooling power										
Water outlet temperature	Fw	°C				8	10	15	20	25
		factor				0.76	0.82	1	1.22	1.43
Ambient temperature	Fa	°C				15	20	25	32	35 40 45
		factor				1.26	1.2	1.12	1	0.95 0.87 0.8
Percentage glycol by weight	Fg	%	0	10	15	20	25	30	35	40
		factor	1	0.96	0.95	0.94	0.93	0.91	0.9	0.88

Cooling power = Nominal cooling power x Fw x Fa x Fg
 *20,100 W is the maximum achievable cooling capacity for Size 2 chillers.

PERFORMANCE DATA TALA1/A3/A5/A8

Imperial

Model		TALA1	TALA3	TALA5	TALA8
Rated Cooling Capacity*	BTU/hr	38900	42300	60700	68600
Ambient temperature operating limits	°F	+59 -+113			
Settable fluid temperature range	°F	+46 -+77			
Fluid type		Water			
Temperature precision	°F	+/-3.6			
Refrigerant gas	HFC	R410a			
Power supply					
Supply voltage	V ph Hz	460 V (+/-10%) 3 ph 50/60 Hz			
Controller supply voltage	VAC	24 V AC			
Digital thermostat		TX200			
Compressor					
Compressor type		Scroll			
Quantity - Number of circuits	no.	1 - 1			
Nominal power draw	kW	3.03	3.12	4.08	4.91
Axial Fan					
Fan type		Axial			
Quantity	no.	1			
Air flow rate	cfm	3820			
Centrifugal Fan (optional)					
Fan type		Centrifugal			
Quantity	no.	1			
Air flow rate	cfm	3820			
Available head	in. H ₂ O	1			
Standard Pump					
Pump type		Centrifugal			
Quantity	no.	1			
Nominal/max fluid flow rate	gpm	8.2 - 18.5	9.2 - 18.5	13.2 - 18.5	15.3 - 18.5
Nominal available head	psi	54	51	41	36
High-Pressure Pump (optional)					
Pump type		Centrifugal			
Quantity	no.	1			
Nominal available head	psi	75	72	72	61
Storage tank capacity	gal	34.3			
IN/OUT liquid connections	in	1"			
Net weight (approximate)***	lbs	441	441	518	518
Width - Depth - Height	in	29.5 - 37.4 - 60.1			
Sound pressure level**	dB(A)	67			

* Data relates to operation under the following conditions: inlet/outlet temp. 68/59°F, water without glycol, ambient temperature 90°F.

** Sound pressure level, measured in a free parallelepiped field at a distance of 1 m, per ISO 3746.

*** Weight includes pallets and packaging (where provided for), with refrigerant charge, storage tank empty, axial fans.



The electrical data refer to cos φ = 0.8.

Correction factors for calculating the cooling power										
Water outlet temperature	Fw	°F				46	50	59	68	77
		factor				0.76	0.82	1	1.22	1.43
Ambient temperature	Fa	°F				59	68	77	90	95 104 113
		factor				1.26	1.2	1.12	1	0.95 0.87 0.8
Percentage glycol by weight	Fg	%	0	10	15	20	25	30	35	40
		factor	1	0.96	0.95	0.94	0.93	0.91	0.9	0.88

Cooling power = Nominal cooling power x Fw x Fa x Fg
 *68,600 BTU/hr is the maximum achievable cooling capacity for Size 2 Chillers.

DRAWINGS SIZE 2: TALA1/A3/A5/A8

Notes

1. Units: mm
2. PQE – Door electrical cabinet
3. FM – Air filter
4. FT – Filling up tank
5. GS – Lifting eye bolts
6. IN/OUT - Inlet and Outlet of water
7. VS – Discharge fluid tank
8. TR – Thermostat
9. VL – Visual tank level
10.  – Installation area
11.  – Air flow through condenser

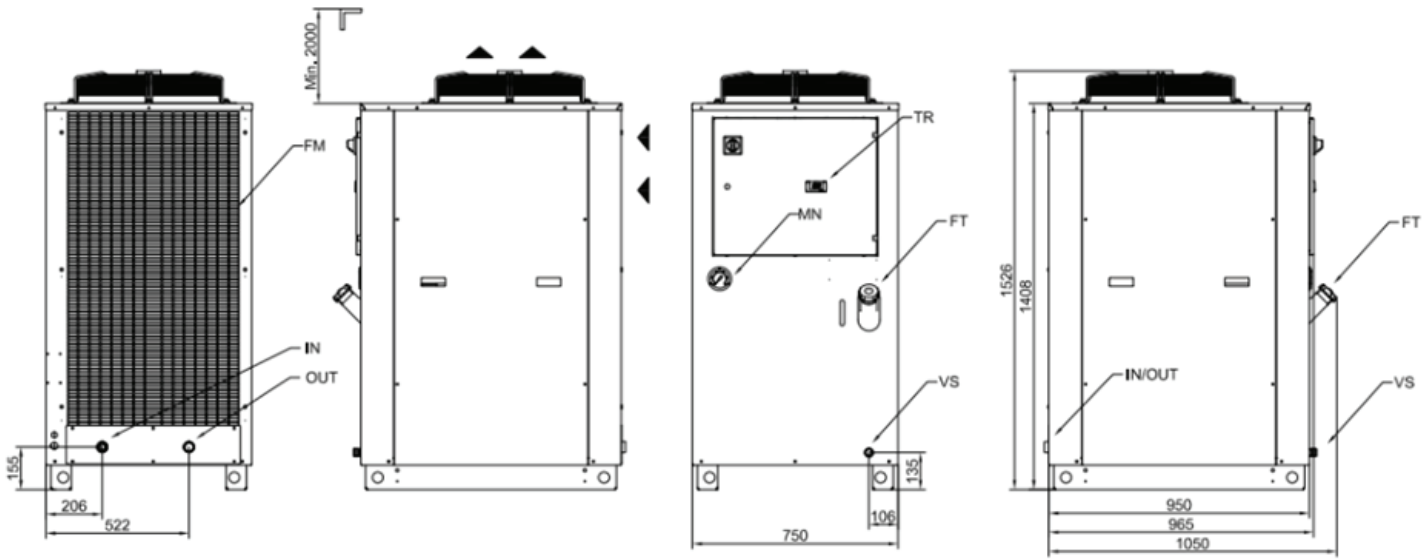
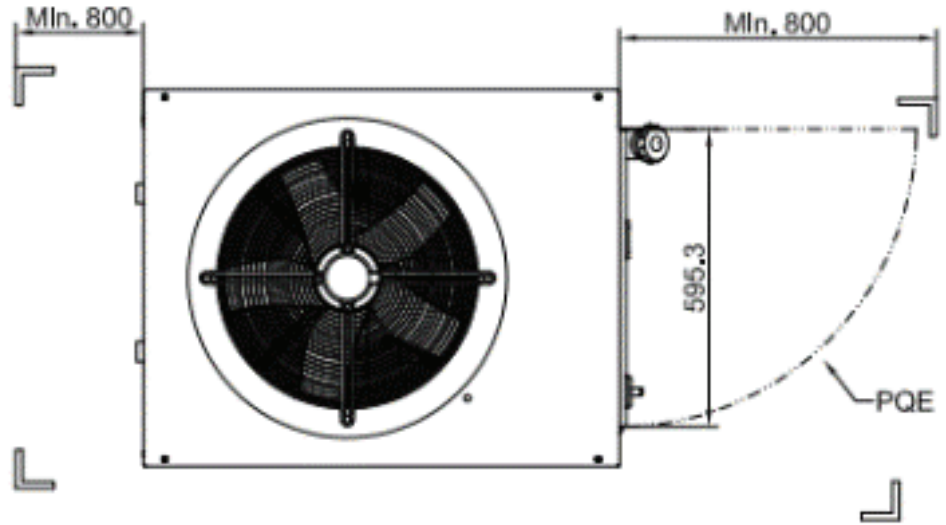

PERFORMANCE DATA SIZE 3: TALB5/B9/C5

Metric

Model		TALB5	TALB9	TALC5
Rated Cooling Capacity*	W	24800	29000	35800
Ambient temperature operating limits	°C	+15 -+45		
Settable fluid temperature range	°C	+8 -+25		
Fluid type		Water		
Temperature precision	K	+/-2		
Refrigerant gas	HFC	R410A		
Power supply				
Supply voltage	V ph Hz	460 V (+/-10%) 3 ph 50/60 Hz		
Controller supply voltage	V	24 V AC		
Digital thermostat		TX200		
Compressor				
Compressor type		Scroll		
Quantity - Number of circuits	no.	1 - 1		
Nominal power draw	kW	6.4	7.4	8.6
Axial Fan				
Fan type		Axial		
Quantity	no.	1		
Air flow rate	m³/h	8300	9700	11500
Centrifugal Fan (optional)				
Fan type		Centrifugal		
Quantity	no.	1		
Air flow rate	m³/h	8300	9700	11500
Available head	Pa	370	180	100
Standard Pump				
Pump type		Centrifugal		
Quantity	no.	1		
Nominal/max fluid flow rate	l/min	79 - 150	92 - 150	100 - 150
Nominal available head	bar	3.5	3.2	3.0
High-Pressure Pump (optional)				
Pump type		Centrifugal		
Quantity	no.	1		
Nominal available head	bar	5.4	5.1	4.9
Storage tank capacity	l	130		
IN/OUT liquid connections	mm	1 1/2"		
Net weight (approximate)***	kg	260	260	260
Width - Depth - Height	mm	900 - 1200 - 1965		
Sound pressure level**	dB(A)	67		

* Data relates to operation under the following conditions: inlet/outlet temp. 20/15°C, water without glycol, ambient temperature 32°C.

** Sound pressure level, measured in a free parallelepiped field at a distance of 1 m, per ISO 3746.

*** Weight includes pallets and packaging (where provided for), with refrigerant charge, storage tank empty, axial fans.

The electrical data refer to $\cos \varphi = 0.8$.

Correction factors for calculating the cooling power												
Water outlet temperature	Fw	°C				8	10	15	20	25		
		factor				0.79	0.84	1	1.18	1.37		
Ambient temperature	Fa	°C				15	20	25	32	35	40	45
		factor				1.25	1.2	1.09	1	0.97	0.91	0.87
Percentage glycol by weight	Fg	%	0	10	15	20	25	30	35	40		
		factor	1	0.96	0.95	0.94	0.93	0.91	0.9	0.88		

Cooling power = Nominal cooling power x Fw x Fa x Fg
 *35,800 W is the maximum achievable cooling capacity for Size 3 chillers.

PERFORMANCE DATA SIZE 3: TALB5/B9/C5

Imperial

Model		TALB5	TALB9	TALC5
Rated Cooling Capacity*	BTU/hr	84600	99000	122100
Ambient temperature operating limits	°F	+59 -+113		
Settable fluid temperature range	°F	+46 -+77		
Fluid type		Water		
Temperature precision	°F	+/-3.6		
Refrigerant gas	HFC	R410A		
Power supply				
Supply voltage	V ph Hz	460 V (+/-10%) 3 ph 50/60 Hz		
Controller supply voltage	V	24 V AC		
Digital thermostat		TX200		
Compressor				
Compressor type		Scroll		
Quantity - Number of circuits	no.	1 - 1		
Nominal power draw	kW	6.4	7.4	8.6
Axial Fan				
Fan type		Axial		
Quantity	no.	1		
Air flow rate	cfm	4880	5710	6770
Centrifugal Fan (optional)				
Fan type		Centrifugal		
Quantity	no.	1		
Air flow rate	cfm	4880	5710	6770
Available head	in. H ₂ O	1.5	0.7	0.4
Standard Pump				
Pump type		Centrifugal		
Quantity	no.	1		
Nominal/max fluid flow rate	gpm	20.1 - 39.6	24.3 - 39.6	26.4 - 39.6
Nominal available head	psi	51	46	44
High-Pressure Pump (optional)				
Pump type		Centrifugal		
Quantity	no.	1		
Nominal available head	psi	78	74	71
Storage tank capacity	gal	34,3		
IN/OUT liquid connections	in	1 1/2"		
Net weight (approximate)***	lbs	573	573	573
Width - Depth - Height	in	35.4 - 47.2 - 77.4		
Sound pressure level**	dB(A)	67		

* Data relates to operation under the following conditions: inlet/outlet temp. 68/59°F, water without glycol, ambient temperature 90°F.

** Sound pressure level, measured in a free parallelepiped field at a distance of 1 m, per ISO 3746.

*** Weight includes pallets and packaging (where provided for), with refrigerant charge, storage tank empty, axial fans.



The electrical data refer to cos φ = 0.8.

Correction factors for calculating the cooling power										
Water outlet temperature	Fw	°F	46	50	59	68	77			
		factor	0.79	0.84	1	1.18	1.37			
Ambient temperature	Fa	°F	59	68	77	90	95	104	113	
		factor	1.25	1.2	1.09	1	0.97	0.91	0.87	
Percentage glycol by weight	Fg	%	0	10	15	20	25	30	35	40
		factor	1	0.96	0.95	0.94	0.93	0.91	0.9	0.88

Cooling power = Nominal cooling power x Fw x Fa x Fg
 *122,100 BTU/hr is the maximum achievable cooling capacity for Size 3 chillers.

DRAWINGS SIZE 3: TALB5/B9/C5

Notes

1. Units: mm
2. MN – Gauge
3. VS – Discharge fluid tank
4. TR – Thermostat
5. VL – Visual tank level
6. PQE – Door electrical cabinet
7. FA – Air filter (optional)
8. FT – Filling up tank
9. GS – Lifting eye bolts
10. IN/OUT - Inlet and Outlet of water
11.  – Installation area
12.  – Air flow through condenser

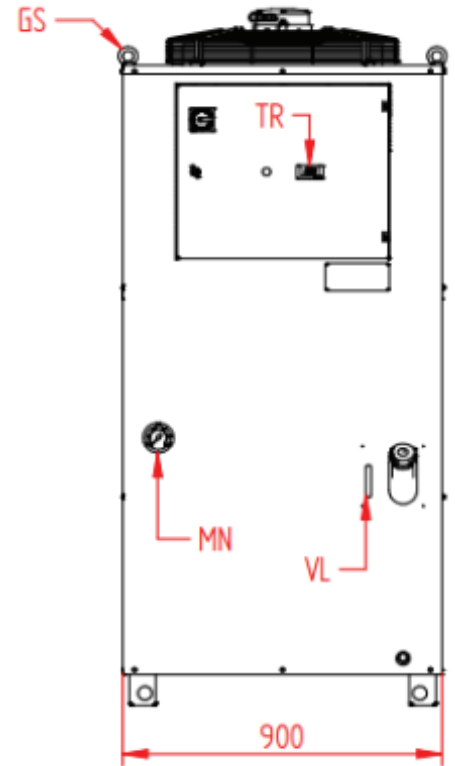
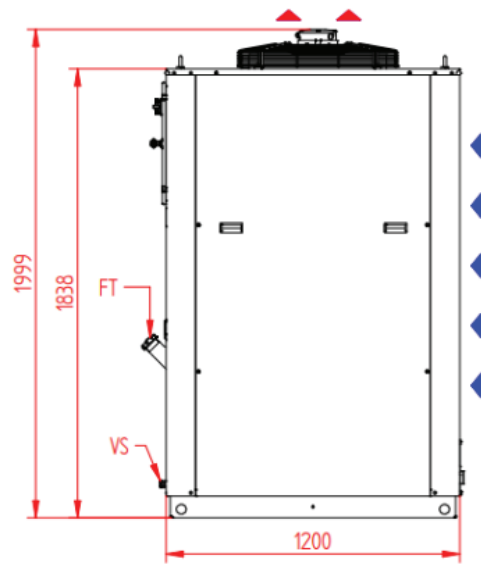
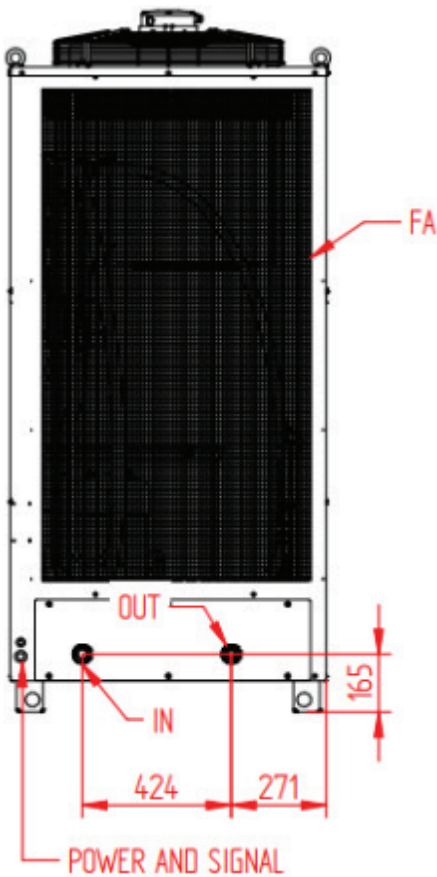
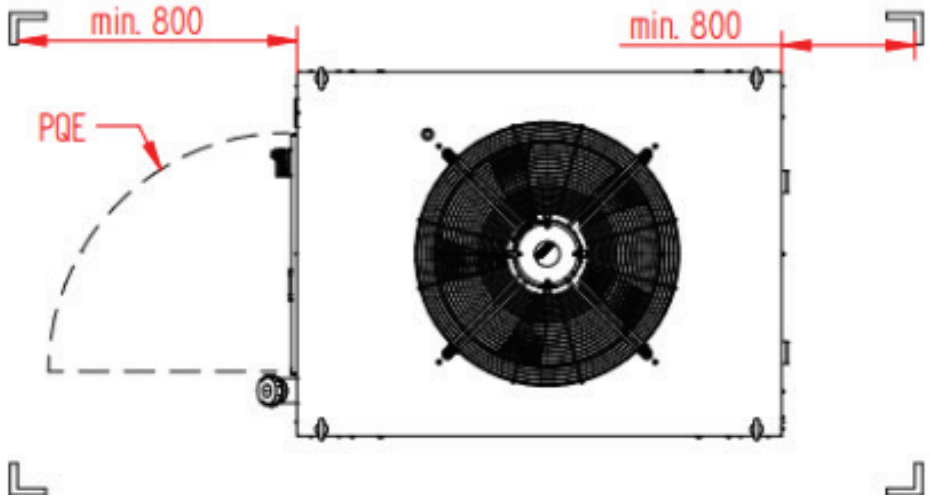

PERFORMANCE DATA SIZE 4: TALD0/D9/E6

Metric

Model		TALD0	TALD9	TALE6
Rated Cooling Capacity*	W	40000	47000	55000
Ambient temperature operating limits	°C	+15 -+45		
Settable fluid temperature range	°C	+8 -+25		
Fluid type		Water		
Temperature precision	K	+/-2		
Refrigerant gas	HFC	R410A		
Power supply				
Supply voltage	V ph Hz	460 V (+/-10%) 3 ph 50/60 Hz		
Controller supply voltage	V	24 V AC		
Digital thermostat		TX350C		
Compressor				
Compressor type		Scroll		
Quantity - Number of circuits	no.	1 - 1		
Nominal power draw	kW	9.4	10.4	12.1
Axial Fan				
Fan type		Axial		
Quantity	no.	1		
Air flow rate	m³/h	12600	14400	16000
Centrifugal Fan (optional)				
Fan type		Centrifugal		
Quantity	no.	1		
Air flow rate	m³/h	12600	14400	16000
Available head	Pa	570	350	200
Standard Pump				
Pump type		Centrifugal		
Quantity	no.	1		
Nominal/max fluid flow rate	l/min	115 - 230	135 - 230	158 - 230
Nominal available head	bar	3.8	3.6	4.6
High-Pressure Pump (optional)				
Pump type		Centrifugal		
Quantity	no.	1		
Nominal available head	bar	6.5	6.2	6.7
Storage tank capacity	l	200		
IN/OUT liquid connections	mm	1 1/2"		
Net weight (approximate)***	kg	580	600	600
Width - Depth - Height	mm	945 - 1795 - 2138		
Sound pressure level**	dB(A)	75		

* Data relates to operation under the following conditions: inlet/outlet temp. 20/15°C, water without glycol, ambient temperature 32°C.

** Sound pressure level, measured in a free parallelepiped field at a distance of 1 m, per ISO 3746.

*** Weight includes pallets and packaging (where provided for), with refrigerant charge, storage tank empty, axial fans.

The electrical data refer to $\cos \varphi = 0.8$.

Correction factors for calculating the cooling power										
Water outlet temperature	Fw	°C				8	10	15	20	25
		factor				0.77	0.83	1	1.2	1.41
Ambient temperature	Fa	°C				15	20	25	32	35 40 45
		factor				1.27	1.2	1.13	1	0.95 0.86 0.8
Percentage glycol by weight	Fg	%	0	10	15	20	25	30	35	40
		factor	1	0.96	0.95	0.94	0.93	0.91	0.9	0.88
Cooling power = Nominal cooling power x Fw x Fa x Fg										

PERFORMANCE DATA SIZE 4: TALD0/D9/E6

Imperial

Model		TALD0	TALD9	TALE6
Rated Cooling Capacity*	BTU/hr	136500	160400	187700
Ambient temperature operating limits	°F	+59 -+113		
Settable fluid temperature range	°F	+46 -+77		
Fluid type		Water		
Temperature precision	°F	+/-3.6		
Refrigerant gas	HFC	R410A		
Power supply				
Supply voltage	V ph Hz	460 V (+/-10%) 3 ph 50/60 Hz		
Controller supply voltage	V	24 V AC		
Digital thermostat		TX350C		
Compressor				
Compressor type		Scroll		
Quantity - Number of circuits	no.	1 - 1		
Nominal power draw	kW	9.4	10.4	12.1
Axial Fan				
Fan type		Axial		
Quantity	no.	1		
Air flow rate	cfm	7420	8480	9420
Centrifugal Fan (optional)				
Fan type		Centrifugal		
Quantity	no.	1		
Air flow rate	cfm	7420	8480	9420
Available head	in. H ₂ O	2.3	1.4	0.8
Standard Pump				
Pump type		Centrifugal		
Quantity	no.	1		
Nominal/max fluid flow rate	gpm	30.4 - 60.8	35.7 - 60.8	41.7 - 60.8
Nominal available head	psi	55	52	66
High-Pressure Pump (optional)				
Pump type		Centrifugal		
Quantity	no.	1		
Nominal available head	psi	94	90	97
Storage tank capacity	gal	52,8		
IN/OUT liquid connections	in	1 1/2"		
Net weight (approximate)***	lbs	1279	1323	1323
Width - Depth - Height	in	37.2 - 70.7 - 84.2		
Sound pressure level**	dB(A)	75		

* Data relates to operation under the following conditions: inlet/outlet temp. 68/59°F, water without glycol, ambient temperature 90°F.

** Sound pressure level, measured in a free parallelepiped field at a distance of 1 m, per ISO 3746.



*** Weight includes pallets and packaging (where provided for), with refrigerant charge, storage tank empty, axial fans.

The electrical data refer to cos φ = 0.8.

Correction factors for calculating the cooling power										
Water outlet temperature	Fw	°F	46	50	59	68	77			
		factor	0.77	0.83	1	1.2	1.41			
Ambient temperature	Fa	°F	59	68	77	90	95	104	113	
		factor	1.27	1.2	1.13	1	0.95	0.86	0.8	
Percentage glycol by weight	Fg	%	0	10	15	20	25	30	35	40
		factor	1	0.96	0.95	0.94	0.93	0.91	0.9	0.88
Cooling power = Nominal cooling power x Fw x Fa x Fg										

DRAWINGS SIZE 4: TALD0/D9/E6

Notes

1. Units: mm
2. PQE – Door electrical cabinet
3. FM – Air filter
4. FT – Filling up tank
5. GS – Lifting eye bolts
6. IN/OUT - Inlet and Outlet of water
7. VS – Discharge fluid tank
8. TR – Thermostat
9. VL – Visual tank level
10.  – Installation area
11.  – Air flow through condenser

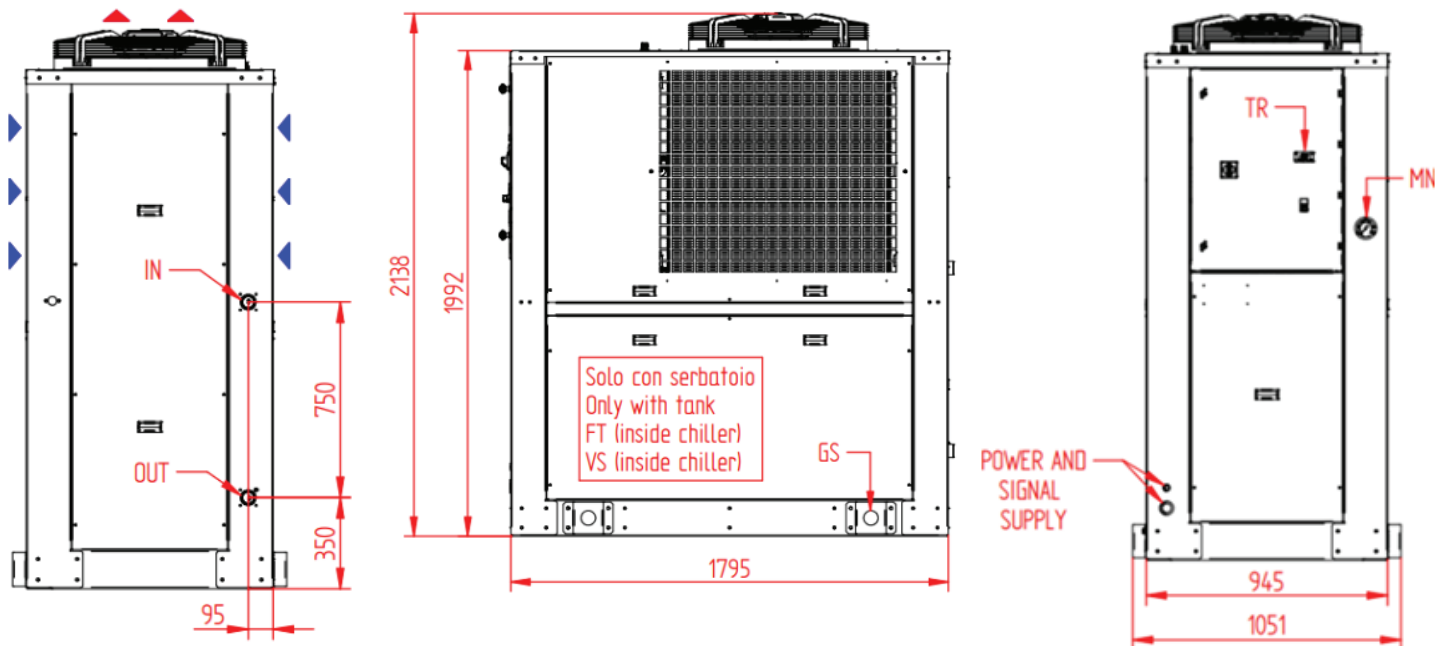
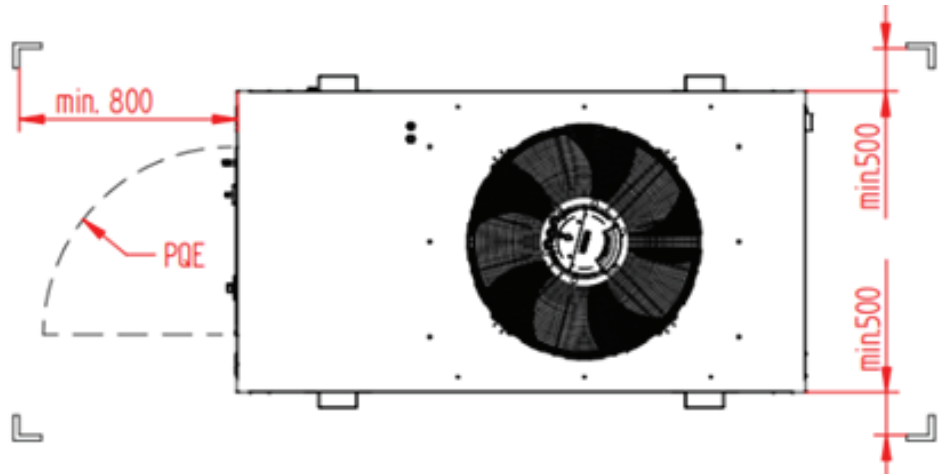

North America

Tel +1.800.545.6258
 Fax +1.800.527.5703
 info@nVent.com

Europe, Middle East, Africa

Tel +32.16.213.511
 Fax +32.16.213.603
 info@nVent.com

Asia Pacific

Tel +86.21.2412.1688
 Fax +86.21.5426.3167
 info@nVent.com

Latin America

Tel +1.713.868.4800
 Fax +1.713.868.2333
 info@nVent.com



Our powerful portfolio of brands:

CADDY ERICO HOFFMAN ILSCO RAYCHEM SCHROFF