

## Wireless BACnet/IP to Allen-Bradley PLC

### FEATURES

- Supports connection to five Allen-Bradley PLCs
- Up to 150 tag or file arrays of data can be mapped in each direction
- Fully configurable BACnet/IP client
- BACnet/IP supports device, binary I/O/V, analog I/O/V, multi-state I/O/V, and character string value object types
- Effortless Browser Based Configuration, no programming software is required
- Simple data translation allows you to manipulate data as it passes between protocols
- 5-Year Hardware Warranty

### Connect BACnet/IP Servers to Allen-Bradley PLCs over Wi-Fi

The 460ETCBC moves data wirelessly between a network of up to 32 BACnet/IP server devices and up to five Allen-Bradley PLCs using Wi-Fi IEEE 802.11 b/g/n at 2.4GHz with AES encryption 128-bit.

With the 460ETCBC, you are making a direct connection between BACnet data and user-defined tags or registers in the data table of your Allen-Bradley PLC. There is no polling from the PLC or EtherNet/IP scan lists to arrange.

### How Do I Use the 460ETCBC-N2EW in My Application?

You allocate two areas of tags or register blocks in your Allen-Bradley PLC. One area is write only tags or register blocks accepting data from BACnet. The other is read only tags or register blocks to send data to your BACnet devices. It's really that simple.

### Why Use Real Time Automation as a Gateway Supplier?

While there are certainly other companies offering protocol gateways, there is no one who provides the level of support and service that you receive from RTA.

When you call, a live person answers the phone. When you talk with sales, you will get honest answers and recommendations. When you get support, it is from an engineer who had a hand in the product's development, and support doesn't require a ticket or 24-hour wait.



**A Solution, A Philosophy, the RTA Way.** We understand the long hours spent on a factory floor and the pressure to keep a line running and product flowing. That's how Real Time Automation came to be. You want easy-to-use solutions where the hardest part is to open the box. You need customer support second to none. If you get all that and a fun customer experience all the better. Thirty years later, our mission remains the same: **To move your data where you need it, when you need it, and how you need it.**

| ETHERNET TAG CLIENT FEATURES  |  |
|---|--|
| PLC Support   | ControlLogix, CompactLogix, FlexLogix, MicroLogix, SLCs and PLC5Es   |
| Maximum Number of PLCs Supported                                    | 5  |
| Maximum Number of Input/Output Tags or Files per PLC                | 150  |
| Maximum Number of Bytes per PLC Tag                                 | 400  |
| Array Support   | Yes, for all data types except strings   |
| Supported Data Types  | Usint, Sint, Uint, Int, Uuint, Dint, Real, String, Bit Array 16, Bit Array 32, Bool, and Long                    |
| BACNET IP CLIENT FEATURES   |  |
| Operation Mode  | BACnet/IP Client   |
| Supported Object Types  | Device, BI/BO/BV, AI/AO/AV, MI/MO/MV, Character String Value   |
| Supported Service Codes   | Read Property-A, Read Property Multiple-A, Write Property-A, Write Property Multiple-A, Device Dynamic Binding-A |
| Maximum Connections   | 32   |
| Number Read/Write Scan Lines per Device                             | 200 Total - 100 reads & 100 writes   |
| Scan Line Support   | Up to 128 Objects  |
| INCLUDED WITH GATEWAY   |  |
| 3' power cable with flying leads                                    | 5-year hardware warranty   |
| IPSetup software – automatically locates RTA gateway on the network | Unlimited firmware feature upgrades for life   |
| CAT5 crossover cable for direct connection to PC during programming | Complete, unlimited access to our industry leading support staff   |
| Manual  |  |

| ELECTRICAL / ENVIRONMENTAL   |  |
|------------------------------|--|
| DC Input Voltage             | 12-24 VDC  |
| Maximum Baud Rate            | 115K baud  |
| Operating Temperature        | -40 C to 85 C  |
| Certification                | RoHS-Compliant, UL, CUL, CE Approvals, Class I Div 2   |
| ENCLOSURE / HARDWARE         |  |
| Size                         | 5.40" x 3.83" x 1.19"  |
| Weight                       | 7.6 oz   |
| Enclosure Type               | Anodized Aluminum  |
| Mounting                     | Din rail or panel mount  |
| LEDs                         | Power LED & 2 general purpose LEDs on side   |
| GATEWAY FEATURES & FUNCTIONS |  |
| Alarming                     | Set <, <=, >, >=, ==, !=, and change-of-state rules on any data moving through the gateway. If alarm rule is triggered an email notification can be sent.      |
| Gateway Security             | You can configure up to 9 different users access to diagnostic and configuration screens.  |
| Translation Table            | Allows for data manipulation during protocol translation. Scaling and other data format changes can occur in the gateway.                                      |
| Status and Counters          | Protocol specific status, counters, and error messages are accessible within the gateway's diagnostics page. They can also be delivered to a connected device. |
| Diagnostic Logging Page      | Allows users to see and log start up sequences, protocol specific messages & error messages.   |

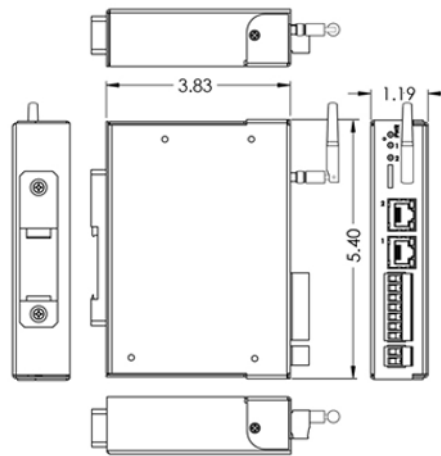

**NOT EXACTLY WHAT YOU WERE LOOKING FOR?**  
 Real Time Automation offers a full line of gateway products. Give us a call at 1-800-249-1612. Or, check out a listing at [www.rtautomation.com/products](http://www.rtautomation.com/products). We also offer customizations for unique applications.

| CATALOG #     | DESCRIPTION   |
|---------------|---|
| 460ETCBC-N2EW | Connects up to five Allen-Bradley PLCs with as many as 32 BACnet/IP servers over wireless |

